

**3 PHASE OPTERON, ATHLON, OR VR10.X CONTROL IC**

**DESCRIPTION**

The IR3093 Control IC provides a full featured, cost effective, single chip solution to implement robust power conversion solutions for three different microprocessor families; 1) AMD's Opteron, 2) AMD's Athlon or 3) Intel's VR-10.X family of processors. The user can select the appropriate VID range with a single pin. Control and 3 phase Gate Drive functions are integrated into a single cost effective IC. . In addition to CPU power, the IR3093 offers a compact, efficient solution for high current POL converters.

**FEATURES**

- 5 bit or 6 bit VID with 0.5% overall system accuracy
- Selectable VID Code for AMD Opteron or Athlon or Intel VR10.X
- Programmable Slew Rate response to "On-the-Fly" VID Code Changes
- 3A GATELX Pull Down Drive Capability
- Programmable 100KHz to 540KHz oscillator
- Programmable Voltage Positioning (can be disabled)
- Programmable Softstart
- Programmable Hiccup Over-Current Protection with Delay to prevent false triggering
- Simplified Powergood provides indication of proper operation and avoids false triggering
- Operates up to 21V input with 7.9V Under-Voltage Lockout
- 5V UVL with 4.36V Under-Voltage Lockout threshold
- Adjustable Voltage, 150mA Bias Regulator provides MOSFET Drive Voltage
- Enable Input
- OVP Flag Output detects high side fet short at powerup
- Pin compatible with IR3092, 2-phase PWM Control IC
- Available 48L MLPQ package

**ORDERING INFORMATION**

Device	Order Quantity
IR3093MTR	3000 per Reel
*IR3093M	100 piece strips

\* Samples Only

**PACKAGE INFORMATION**

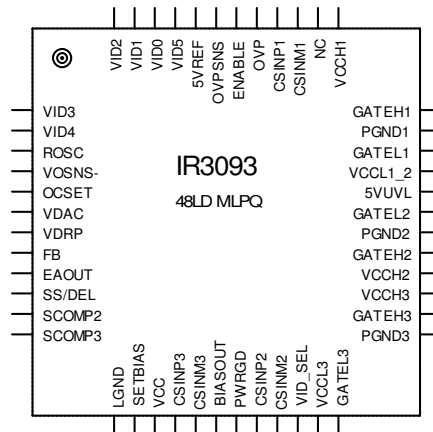

**48L MLPQ**  
 (7 x 7 mm Body)  
 –  $\theta_{JA} = 27^{\circ}\text{C/W}$

**PIN DESCRIPTION**

PIN#	PIN SYMBOL	PIN DESCRIPTION
1	VID3	Inputs to VID D to A Converter
2	VID4	Inputs to VID D to A Converter
3	ROSC	Connect a resistor to VOSNS- to program oscillator frequency and FB, OCSET, BBFB, and VDAC bias currents
4	VOSNS-	Remote Sense Input. Connect to ground at the Load.
5	OCSET	Programs the hiccup over-current threshold through an external resistor tied to VDAC and an internal current source.
6	VDAC	Regulated voltage programmed by the VID inputs. Current Sensing and Over Current Protection are referenced to this pin. Connect an external RC network to VOSNS- to program Dynamic VID slew rate.
7	VDRP	Buffered IIN signal. Connect an external RC network to FB to program converter output impedance
8	FB	Inverting input to the Error Amplifier. Converter output voltage is offset from the VDAC voltage through an external resistor connected to the converter output voltage at the load and an internal current source. Bias current is a function of ROSC. Also OVP sense
9	EAOUT	Output of the Error Amplifier
10	SS/DEL	Controls Converter Softstart, Power Good, and Over-Current Timing. Connect an external capacitor to LGND to program the timing.
11	SCOMP2	Compensation for the Current Share control loop. Connect a capacitor to ground to set the control loop's bandwidth. Phase 2 is forced to match phase 1's current.
12	SCOMP3	Compensation for the Current Share control loop. Connect a capacitor to ground to set the control loop's bandwidth. Phase 3 is forced to match phase 1's current.
13	LGND	Local Ground and IC substrate connection
14	SETBIAS	External resistor to ground sets voltage at BIASOUT pin. Bias current is a function of ROSC.
15	VCC	Power for internal circuitry and source for BIASOUT regulator
16	CSINP3	Non-inverting input to the Phase 3 Current Sense Amplifier.
17	CSINM3	Inverting input to the Phase 3 Current Sense Amplifier.
18	BIASOUT	200mA open-looped regulated voltage set by SETBIAS for GATE drive bias.
19	PWRGD	Open Collector output that drives low during Softstart or any fault condition. Connect external pull-up.
20	CSINP2	Non-inverting input to the Phase 2 Current Sense Amplifier.
21	CSINM2	Inverting input to the Phase 2 Current Sense Amplifier.
22	VID_SEL	Ground Selects VR10.X VID, Float Selects OPTERON VID, VCC Selects ATHLON VID
23	VCCL3	Power for Phase 3 Low-Side Gate Driver.
24	GATEL3	Phase 3 Low-Side Gate Driver Output and input to GATEH3 non-overlap comparator.
25	PGND3	Return for Phase 3 Gate Drivers
26	GATEH3	Phase 3 High-Side Gate Driver Output and input to GATEL3 non-overlap comparator.
27	VCCH3	Power for Phase 3 High-Side Gate Driver
28	VCCH2	Power for Phase 2 High-Side Gate Driver
29	GATEH2	Phase 2 High-Side Gate Driver Output and input to GATEL2 non-overlap comparator.
30	PGND2	Return for Phase 2 Gate Drivers
31	GATEL2	Phase 2 Low-Side Gate Driver Output and input to GATEH2 non-overlap comparator.
32	5VUVL	Can be used to monitor the driver supply voltage or 5V supply voltage when converting from 5V. An under voltage condition initiates Soft Start.
33	VCCL1_2	Power for Phase 1 and 2 Low-Side Gate Drivers.
34	GATEL1	Phase 1 Low-Side Gate Driver Output and input to GATEH1 non-overlap comparator.
35	PGND1	Return for Phase 1 Gate Drivers
36	GATEH1	Phase 1 High-Side Gate Driver Output and input to GATEL1 non-overlap comparator.
37	VCCH1	Power for Phase 1 High-Side Gate Driver
38	NC	Not connected
39	CSINM1	Inverting input to the Phase 1 Current Sense Amplifier.
40	CSINP1	Non-inverting input to the Current Sense Amplifier.
41	OVP	Output that drives high during an Over-Voltage condition.
42	ENABLE	Enable Input. A logic low applied to this pin puts the IC into Fault mode.
43	OVPSNS	Dedicated output voltage sense pin for Over Voltage Protection.
44	5VREF	Compensation for internal voltage reference rail.
45	VID5	Inputs to VID D to A Converter
46	VID0	Inputs to VID D to A Converter
47	VID1	Inputs to VID D to A Converter
48	VID2	Inputs to VID D to A Converter

**ABSOLUTE MAXIMUM RATINGS**

Operating Junction Temperature.....150°C  
 Storage Temperature Range.....-65°C to 150°C

PIN	NAME	VMAX	VMIN	ISOURCE	ISINK
1	VID3	30V	-0.3V	1mA	1mA
2	VID4	30V	-0.3V	1mA	1mA
3	ROSC	30V	-0.5V	1mA	1mA
4	VOSNS-	0.5V	-0.5V	10mA	10mA
5	OCSET	30V	-0.3V	1mA	1mA
6	VDAC	30V	-0.3V	1mA	1mA
7	VDRP	30V	-0.3V	5mA	5mA
8	FB	30V	-0.3V	1mA	1mA
9	EAOUT	10V	-0.3V	10mA	20mA
10	SS/DEL	30V	-0.3V	1mA	1mA
11	SCOMP2	30V	-0.3V	5mA	5mA
12	SCOMP3	30V	-0.3V	5mA	5mA
13	LGND	n/a	n/a	50mA	1mA
14	SETBIAS	30V	-0.3V	1mA	1mA
15	VCC	30V	-0.3V	1mA	250mA
16	CSINP3	30V	-0.3V	250mA	1mA
17	CSINM3	30V	-0.3V	250mA	1mA
18	BIASOUT	30V	-0.3V	250mA	1mA
19	PWRGD	30V	-0.3V	1mA	20mA
20	CSINP2	30V	-0.3V	250mA	1mA
21	CSINM2	30V	-0.3V	250mA	1mA
22	VID_SEL	30V	-0.3V	1mA	1mA
23	VCCL3	30V	-0.3V	n/a	3A for 100ns, 200mA DC
24	GATEL3	30V	-0.3V DC, -2V for 100ns	3A for 100ns, 200mA DC	3A for 100ns, 200mA DC
25	PGND3	0.3V	-0.3V	3A for 100ns, 200mA DC	n/a
26	GATEH3	30V	-0.3V DC, -2V for 100ns	3A for 100ns, 200mA DC	3A for 100ns, 200mA DC
27	VCCH3	30V	-0.3V	n/a	3A for 100ns, 200mA DC
28	VCCH2	30V	-0.3V	n/a	3A for 100ns, 200mA DC
29	GATEH2	30V	-0.3V DC, -2V for 100ns	3A for 100ns, 200mA DC	3A for 100ns, 200mA DC
30	PGND2	0.3V	-0.3V	3A for 100ns, 200mA DC	n/a
31	GATEL2	30V	-0.3V DC, -2V for 100ns	3A for 100ns, 200mA DC	3A for 100ns, 200mA DC
32	5VUVL	30V	-0.3V	1mA	1mA
33	VCCL1_2	30V	-0.3V	n/a	3A for 100ns, 200mA DC
34	GATEL1	30V	-0.3V DC, -2V for 100ns	3A for 100ns, 200mA DC	3A for 100ns, 200mA DC
35	PGND1	0.3V	-0.3V	3A for 100ns, 200mA DC	n/a
36	GATEH1	30V	-0.3V DC, -2V for 100ns	3A for 100ns, 200mA DC	3A for 100ns, 200mA DC
37	VCCH1	30V	-0.3V	n/a	3A for 100ns, 200mA DC
38	NC	n/a	n/a	n/a	n/a
39	CSINM1	30V	-0.3V	250mA	1mA
40	CSINP1	30V	-0.3V	250mA	1mA
41	OVP	30V	-0.3V	1mA	1mA
42	ENABLE	30V	-0.3V	1mA	1mA
43	OVPSNS	30V	-0.3V	1mA	1mA
44	5VREF	10V	-0.3V	10mA	20mA
45	VID5	30V	-0.3V	1mA	1mA
46	VID0	30V	-0.3V	1mA	1mA
47	VID1	30V	-0.3V	1mA	1mA
48	VID2	30V	-0.3V	1mA	1mA

**ELECTRICAL SPECIFICATIONS**

Unless otherwise specified, these specifications apply over:  $7.4V \leq V_{CC} \leq 21V$ ,  $4V \leq V_{CCLX} \leq 14V$ ,  $4V \leq V_{CCHX} \leq 28V$ ,  $C_{GATEHX} = 3.3nF$ ,  $C_{GATELX} = 6.8nF$ ,  $0^{\circ}C \leq T_J \leq 125^{\circ}C$

PARAMETER	TEST CONDITION	MIN	TYP	MAX	UNIT
<b>VDAC Reference</b>					
System Set-Point Accuracy	-0.3V $\leq$ VOSNS- $\leq$ 0.3V, Connect FB to EAOUT, Measure V(EAOUT) – V(VOSNS-) deviation from Table 1. Applies to all VID codes.		0.5		%
Sink Current	R <sub>ROSC</sub> = 47k $\Omega$ , VDAC=OCSET	45	53	61	$\mu$ A
Source Current	R <sub>ROSC</sub> = 47k $\Omega$ , VDAC=OCSET	48	56	64	
VID Input Threshold, INTEL	VID_SEL=0, Referenced to VOSNS-	0.4	0.6	0.8	V
VID Input Threshold, AMD	VID_SEL=Float, Referenced to VOSNS-	1.55	1.65	1.75	V
VID_SEL OPTERON Threshold		1.0	1.2	1.4	V
VID_SEL ATHLON Threshold		3.0	3.3	3.8	V
VID_SEL Float Voltage	Tracks ATHLON threshold	2.1	2.6	3.2	V
VID_SEL Pull-up Resistance	V(VID_SEL)<2.1V	30	50	100	k $\Omega$
VID_SEL Pull-down Resistance	V(VID_SEL)>3.2V	60	150	350	k $\Omega$
VID Pull-up Current	VID0-5 = 1V	9	18	27	$\mu$ A
VID Float Voltage	Referenced to LGND	4.5	4.9	5.2	V
VID = 11111 Fault Blanking	Delay to PWRGD assertion	0.5	2.1	4.1	$\mu$ s
<b>Error Amplifier</b>					
Input Offset Voltage	Connect FB to EAOUT, Measure V(EAOUT)-V(VDAC). Applies to all VID codes and -0.3V<VOSNS-<0.3V. Note 2.	-5	-1	3	mV
FB Bias Current	R <sub>ROSC</sub> = 47k $\Omega$	23.5	26.4	29.4	$\mu$ A
DC Gain	Note 1	90	100	105	dB
Gain-Bandwidth Product	Note 1	4	7		MHz
Slew Rate	Note 1, 50mV FB signal		1.25		V/ $\mu$ s
Source Current		300	430	600	$\mu$ A
Sink Current		.75	1.1	1.5	mA
Max Voltage		4.5	4.9	5.3	V
Min Voltage			50	200	mV
<b>VDRP Buffer Amplifier</b>					
Positioning Offset Voltage	V(VDRP) – V(VDAC) with CSINMX=CSINPX=0. Note 1.	-125	0	125	mV
Output Voltage Range		0.2		3.75	V

PARAMETER	TEST CONDITION	MIN	TYP	MAX	UNIT
<b>VDRP Buffer Amplifier cont.</b>					
Source Current		4	8	20	mA
Sink Current		200	300	650	μA
<b>Oscillator</b>					
Switching Frequency	R <sub>ROSC</sub> = 47kΩ	160	200	240	kHz
Phase Shift	Sequence: GATEH1-GATEH2-GATEH3	102	120	138	°
<b>BIASOUT Regulator</b>					
SETBIAS Bias Current	R <sub>ROSC</sub> = 47kΩ	94	103	117.5	μA
Set Point Accuracy	V(SETBIAS)-V(BIASOUT) @ 100mA	0.1	0.25	0.55	V
BIASOUT Dropout Voltage	I(BIASOUT)=100mA, Threshold when V(SETBIAS)-V(BIASOUT)=0.45V	1.2	1.8	2.5	V
BIASOUT Current Limit		150	250	450	mA
<b>Soft Start and Delay</b>					
SS/DEL to FB Input Offset Voltage	With FB = 0V, adjust V(SS/DEL) until EAOUT drives high	0.8	1.1	1.8	V
Charge Current		30	60	90	μA
Hiccup Discharge Current		3.5	6	9	μA
OC Discharge Current		25	55	70	μA
Charge/Discharge Current Ratio		9	10	13	μA/μA
Charge Voltage		3.8	4.0	4.2	V
Delay Comparator Threshold	Relative to Charge Voltage	190	250	300	mV
Discharge Comparator Threshold		170	265	350	mV
<b>Over-Current Comparator</b>					
Input Offset Voltage	V(OCSET)-V(VDAC), CSINM=CSINP1=CSINP2=CSINP3, Note 1.	-125	0	125	mV
OCSET Bias Current	R <sub>ROSC</sub> = 47kΩ	23.5	27	29.4	μA
Max OCSET Set Point		3.9			V
<b>Under-Voltage Lockout</b>					
VCC Start Threshold		7.4	7.9	8.4	V
VCC Stop Threshold		6.9	7.4	7.9	V
VCC Hysteresis	Start – Stop	400	540	700	mV
5VUVL Start Threshold		4.05	4.36	4.55	V
5VUVL Stop Threshold		3.92	4.17	4.33	V
5VUVL Hysteresis	Start – Stop	100	200	250	mV

PARAMETER	TEST CONDITION	MIN	TYP	MAX	UNIT
<b>PWRGD Output</b>					
Output Voltage	I(PWRGD) = 4mA		150	400	mV
Leakage Current	V(PWRGD) = 5.5V		0	10	μA
<b>Enable Input</b>					
Threshold, INTEL	VID_SEL=0, Referenced to VOSNS-	0.4	0.6	0.8	V
Threshold, AMD	VID_SEL=Float, Referenced to VOSNS-	1.3	1.5	1.7	V
Input Resistance		5	10	20	kΩ
Pull-up Voltage		2.4	3.0	3.7	V
<b>Gate Drivers</b>					
GATEH Rise Time	VCCHX = 8V, Measure 1V to 7V transition time. Note 1.		25	50	ns
GATEH Fall Time	VCCHX = 8V, Measure 7V to 1V transition time. Note 1.		25	50	ns
GATEL Rise Time	VCCLX= 8V, Measure 1V to 7V transition time. Note 1.		50	90	ns
GATEL Fall Time	VCCLX= 8V, Measure 7V to 1V transition time. Note 1.		30	60	ns
High Voltage (AC)	Measure VCCLX– GATELX or VCCHX – GATEHX, Note 1		0	0.5V	V
Low Voltage (AC)	Measure GATELX or GATEHX, Note 1		0	0.5V	V
GATEL low to GATEH high delay	VCCHX = VCCLX= 8V, Measure the time from GATELX falling to 1V to GATEHX rising to 1V. Note 1.	10	25	50	ns
GATEH low to GATEL high delay	VCCHX = VCCLX= 8V, Measure the time from GATEHX falling to 1V to GATELX rising to 1V. Note 1.	10	25	50	ns
Disable Pull-Down Current	GATHX or GATELX=2V with VCC = 0V. Measure Gate pull-down current	20	35	50	μA
<b>PWM Comparator</b>					
Propagation Delay	Note1		100	150	ns
Common Mode Input Range				4	V
Internal Ramp Start Voltage		0.45	0.6	0.9	V
Internal Ramp Amplitude		35	50	65	mV / %DTC
<b>Current Sense Amplifier</b>					
CSINPX Bias Current		-1	0	1	μA
CSINMX Bias Current		-1	0	1	μA
Input Current Offset Ratio		0.25	1	2	μA/μA
Average Input Offset Voltage	(VDRP-VDAC)/GAIN with CSINX=0. Note1	-5	0	5	mV
Offset Voltage Mismatch	Monitor I(SCOMPX), Note1.	-5	0	5	mV
Gain at T <sub>J</sub> = 25 °C		22	23.5	25	V/V
Gain at T <sub>J</sub> = 125 °C		18.5	20.4	21.5	V/V
Gain Mismatch	Note 1.	-1	0	1	V/V
Differential Input Range		-25		75	mV
Common Mode Input Range		0		2.8	V

PARAMETER	TEST CONDITION	MIN	TYP	MAX	UNIT
<b>Share Adjust Error Amplifier</b>					
Input Offset Voltage	Note 1	-5	0	5	mV
MAX Duty Cycle Adjust Ratio	Compare Duty Cycle to GATEHX	1.5	2.0		
MIN Duty Cycle Adjust Ratio	Compare Duty Cycle to GATEHX	0.6	0.5		
Transconductance	Note 1	100	200	300	$\mu\text{A/V}$
SCOMPX Source/Sink Current		16	22	28	$\mu\text{A}$
Equal Duty Cycle Comparator Threshold		0.45	0.60	0.95	V
Duty Cycle Match at Startup	Compare Duty Cycle to GATEHX	-5	-1	5	%
SCOMPX Precharge Current	V(SS/DEL)=0	300	450	700	$\mu\text{A}$
<b>0% Duty Cycle Comparator</b>					
Threshold Voltage	Below Internal Ramp1 Start Voltage	80	130	180	mV
Propagation Delay	VCCLX= 8V. Step EAOUT from .8V to .3V and measure time to GATELX transition to < 7V.		200	400	ns
Body Breaking Disable Comparator Threshold	Compare V(FB) to V(VDAC)	50	75	110	mV
<b>OVP</b>					
VR10.X Comparator Threshold	VID_SEL=0V. Compare to V(VDAC)	120	150	200	mV
AMD Comparator Threshold	Float VID_SEL. Compare to V(VDAC)	360	450	600	mV
Power-up Headroom for OVP Flag	VCC=OVPSNS where V(OVP)>0.5V. Same for 5VUVL=OVPSNS.	0.8	1.1	1.8	V
OVPSNS Threshold at Power-up	VCC=2V, V(OVP) >0.5V. Same for V(5VUVL)=2V.	0.3	0.48	0.85	V
SS/DEL Power-up Clear Threshold	VCC=12V, V(OVPSNS)=1V, VDAC=1.6V, where OVP<0.5V	0.35	0.60	0.95	V
Propagation Delay	VCCLX= 8V. V(EAOUT)=0V. Step OVPSNS 540mV + V(VDAC). Measure time to GATELX transition to >1V.		275	400	ns
OVP Source Current	V(OVP)=0.5V, VCC=1.8V, 5VUVL=0V	10	75		$\mu\text{A}$
OVP Pull Down Resistance	OVP to LGND	30	60	100	k $\Omega$
OVP High Voltage	I(OVP)=10 $\mu\text{A}$ , V(VCC) or V(5VUVL)-V(OVP), VCC=1.8V	0.4	0.70	1.1	V
OVPSNS Bias Current		-1	0.3	1.5	$\mu\text{A}$
<b>5VREF</b>					
Short Circuit Current		20	45	60	mA
Supply Voltage	I(5VREF)=0A	4.5	5	5.5	V
<b>General</b>					
VCC Supply Current	V(VCC)=21V	33	38	44	mA
VOSNS- Current	-0.3V $\leq$ VOSNS- $\leq$ 0.3V, All VID Codes	3.2	3.7	4.2	mA
VCCHX and VCCL3 Current	V(VCCHX)=28V, V(VCCL3)=14V	3	5	7	mA
VCCL1_2 Supply Current	V(VCCL1_2)=14V	6	10	17	mA
5VUVL Supply Current	V(5VUVL)=5V, no OVP condition	100	200	400	$\mu\text{A}$

**Note 1:** Guaranteed by design, but not tested in production

**Note 2:** Critical limits are identified with **bold** text

**Note 3:** VDAC Output is trimmed to compensate for Error Amp input offsets errors

**TYPICAL OPERATING CHARACTERISTICS**

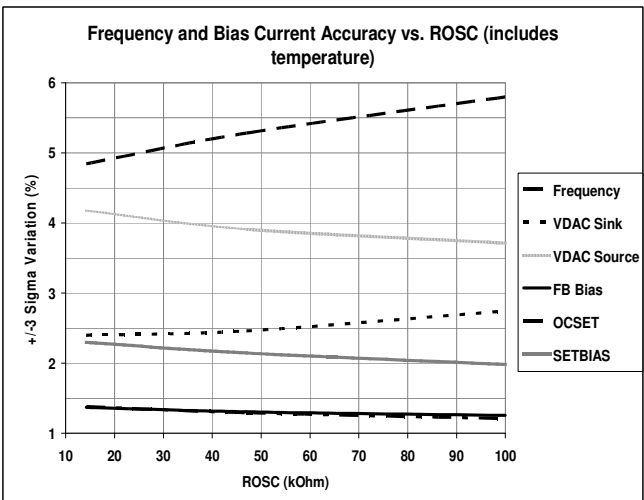
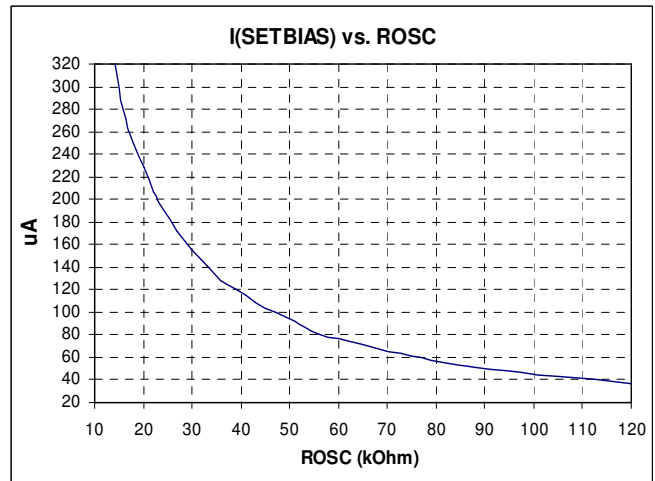
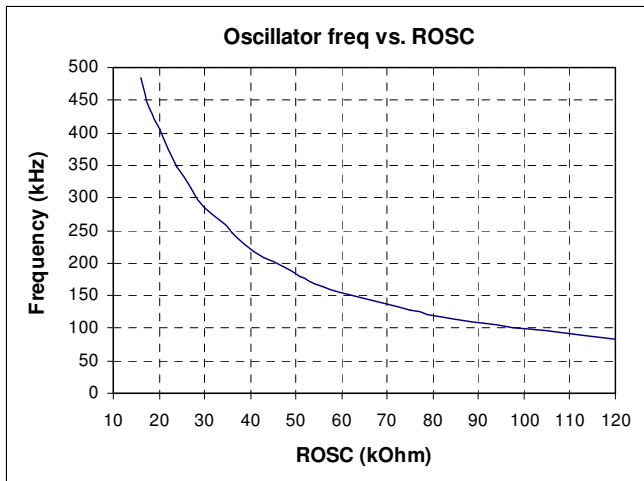
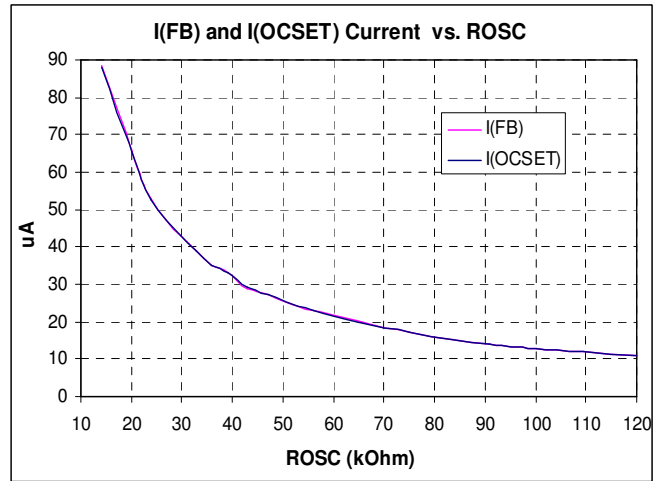
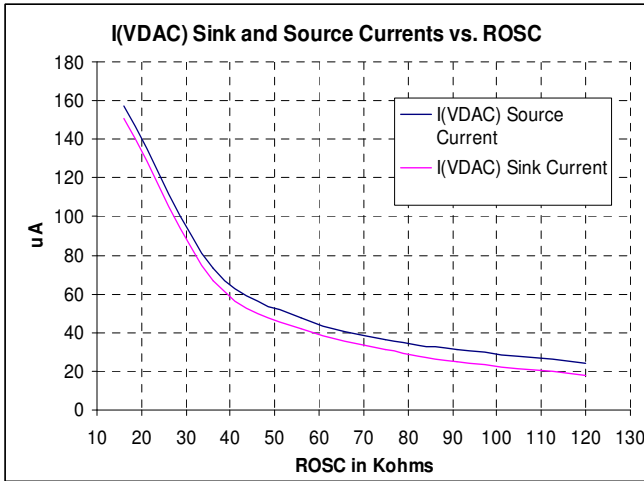

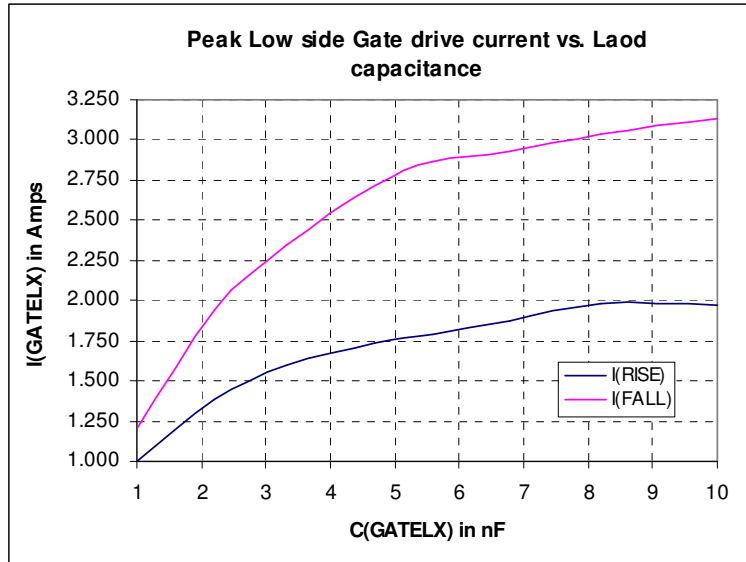

**Error Amplifier Frequency Response**

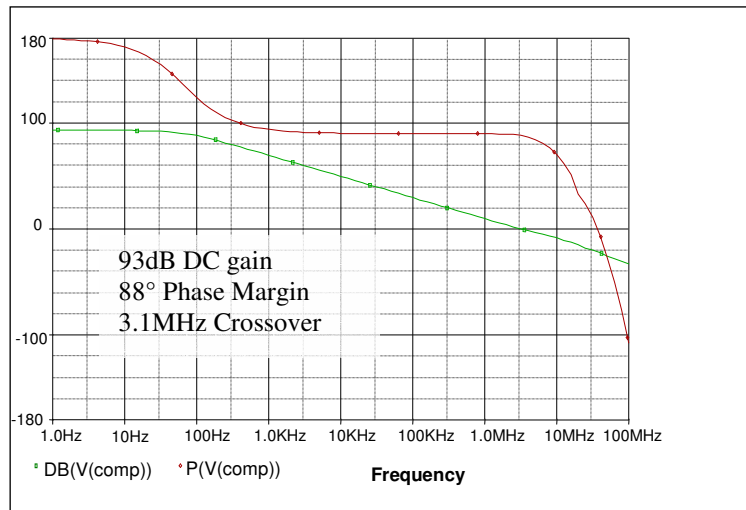

IR3093 THEORY OF OPERATION

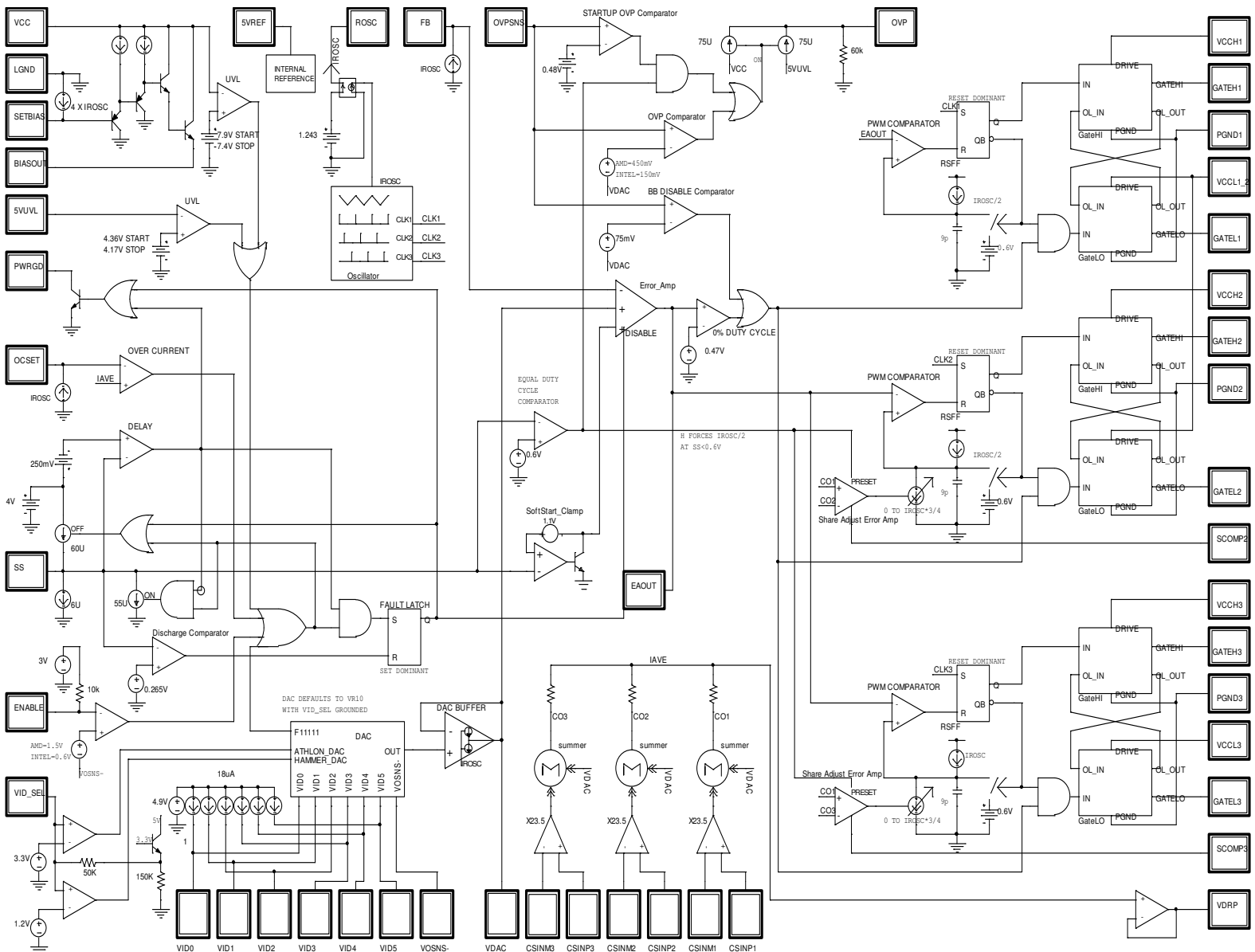
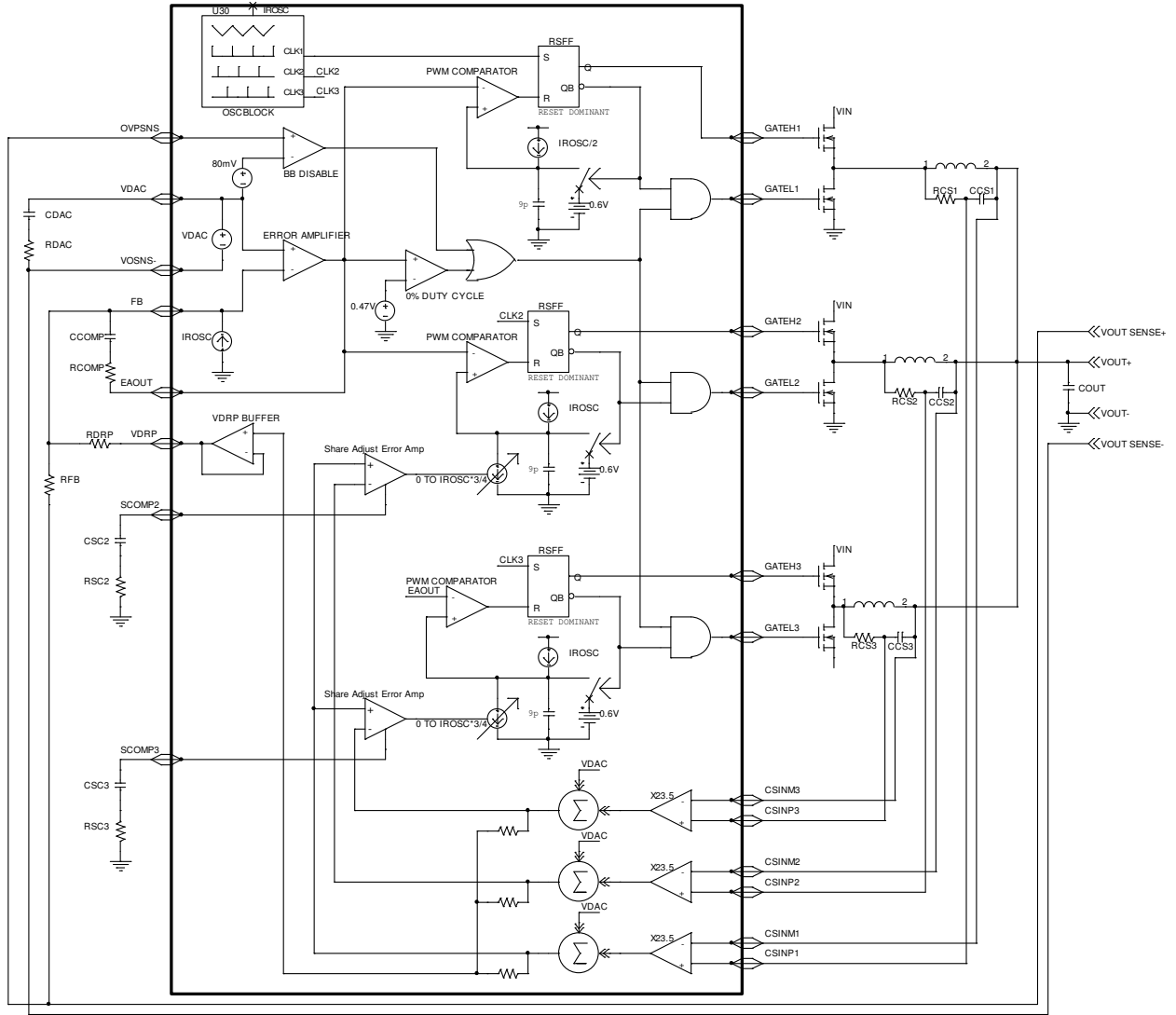

Figure 1 – IR3093 Block Diagram

**PWM Operation**

The IR3093 is a fully integrated 3 phase interleaved PWM control IC which uses voltage mode control with trailing edge modulation. A high-gain wide-bandwidth voltage type Error Amplifier in the Control IC is used for the voltage control loop. The PWM block diagram of the IR3093 is shown in Figure 2.



**Figure 2 – PWM Block Diagram**

Refer to Figure 3. Upon receiving a clock pulse, the RSFF is set, the internal PWM ramp voltage begins to increase, the low side driver is turned off, and the high side driver is then turned on. For phase 1, an internal 9pf capacitor is charged by a current source that proportional to the switching frequency resulting in a ramp rate of 50mV per percent duty cycle. For example, if the steady-state operating switch node duty cycle is 10%, then the internal ramp amplitude is typically 500mV from the starting point (or floor) to the crossing of the EAOUT control voltage. When the PWM ramp voltage exceeds the Error Amplifier's output voltage, the RSFF is reset. This turns off the high side driver, turns on the low side driver, and discharges the PWM ramp to 0.6V until the next clock pulse.

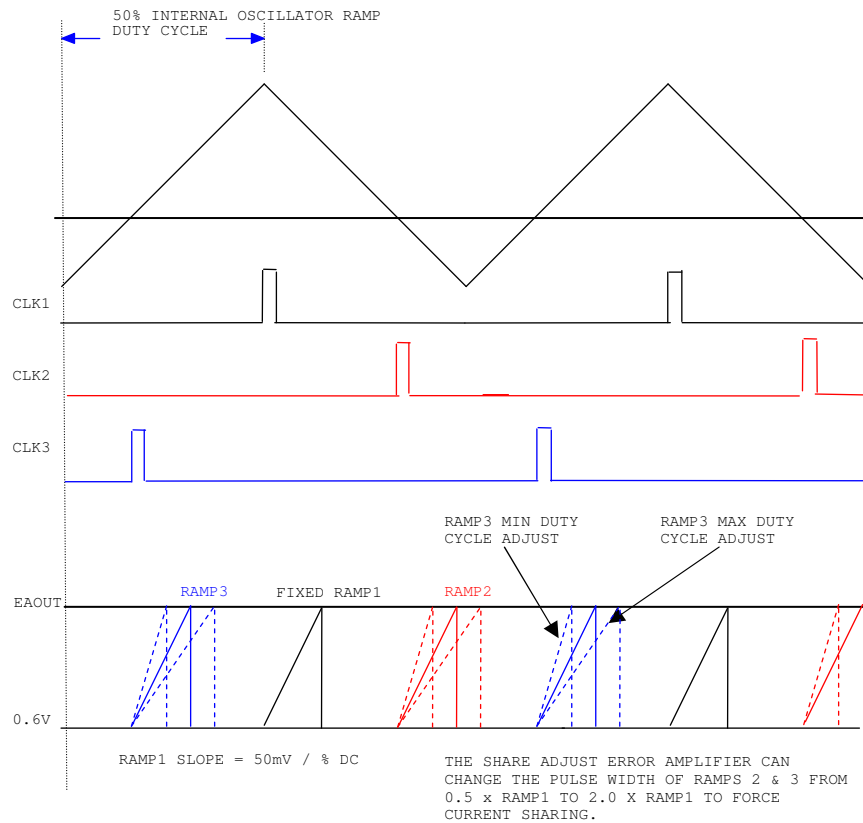

**Figure 3 – 3 Phase Oscillator and PWM Waveforms**

The RSFF is reset dominant allowing both phases to go to zero duty cycle within a few tens of nanoseconds in response to a load step decrease. Phases can overlap and go to 100% duty cycle in response to a load step increase with turn-on gated by the clock pulses. An Error Amplifier output voltage greater than the common mode input range of the PWM comparator results in 100% duty cycle regardless of the voltage of the PWM ramp. This arrangement guarantees the Error Amplifier is always in control and can demand 0 to 100% duty cycle as required. It also favors response to a load step decrease which is appropriate given the low output to input voltage ratio of most systems. The inductor current will increase much more rapidly than decrease in response to load transients.

This control method is designed to provide “single cycle transient response” where the inductor current changes in response to load transients within a single switching cycle maximizing the effectiveness of the power train and minimizing the output capacitor requirements.

### Body Braking™

In a conventional synchronous buck converter, the minimum time required to reduce the current in the inductor in response to a load step decrease is;

$$T_{SLEW} = [L \times (I_{MAX} - I_{MIN})] / V_{out}$$

The slew rate of the inductor current can be significantly increased by turning off the synchronous rectifier in response to a load step decrease. The switch node voltage is then forced to decrease until conduction of the synchronous rectifier’s body diode occurs. This increases the voltage across the inductor from  $V_{out}$  to  $V_{out} + V_{BODY DIODE}$ . The minimum time required to reduce the current in the inductor in response to a load transient decrease is now;

$$T_{SLEW} = [L \times (I_{MAX} - I_{MIN})] / (V_{out} + V_{BODY DIODE})$$

Since the voltage drop in the body diode is often higher than output voltage, the inductor current slew rate can be increased by 2X or more. This patent pending technique is referred to as “body braking” and is accomplished through the “0% Duty Cycle Comparator”. If the Error Amplifier’s output voltage drops below 0.47V, this comparator turns off the low side gate driver.

Figure 4 depicts PWM operating waveforms under various conditions

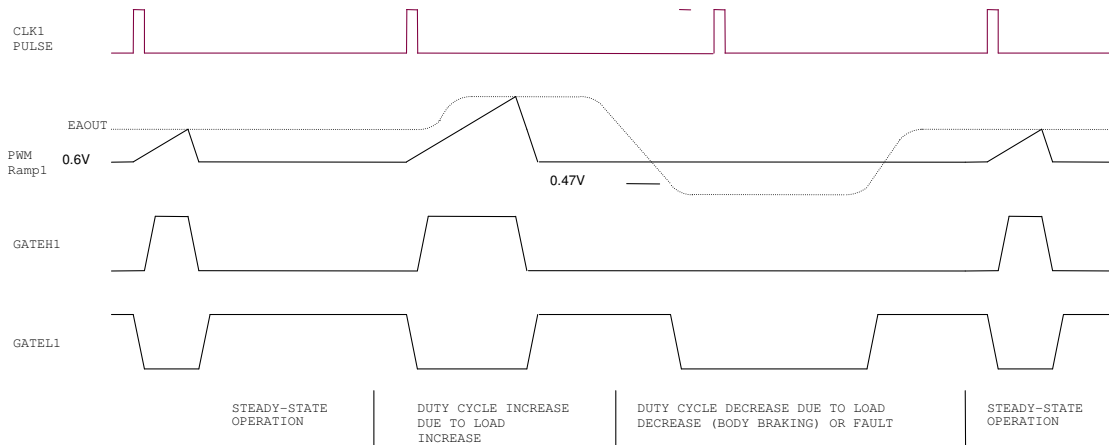

Figure 4 – PWM Operating Waveforms

### Current Sense Amplifier

A high speed differential current sense amplifier is shown in Figure 5. Its gain decreases with increasing temperature and is nominally 23.5 at 25°C and 20.4 at 125°C (-1400 ppm/°C). This reduction of gain tends to compensate the 3850 ppm/°C increase in inductor DCR. Since in most designs the IR3093 IC junction is hotter than the inductors these two effects tend to cancel such that no additional temperature compensation of the load line is required.

The current sense amplifier can accept positive differential input up to 75mV and negative up to -25mV before clipping. The output of the current sense amplifier is summed with the DAC voltage which is used for over current protection, voltage positioning and current sharing.

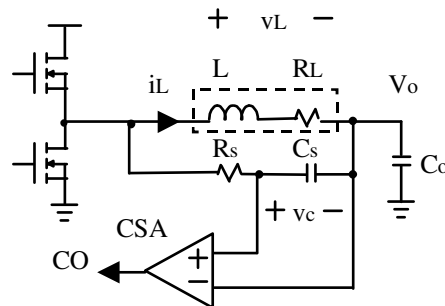

Figure 5 – Inductor Current Sensing and Current Sense Amplifier

### VCC Under Voltage Lockout (UVLO)

The VCC UVLO function monitors the IR3093's VCC supply pin and ensures enough voltage is available to power the internal circuitry. During power-up the fault latch is reset when VCC exceeds 7.9V and all other faults are cleared. The fault latch is set when VCC drops below 7.4V and SS/DEL is below 3.75V.

### 5VUVL Under Voltage Lockout (5VUVL)

The 5VUVL function is provided for converters using a separate voltage supply other than VCC for gate driver bias. The 5VUVL comparator prevents operation by discharging SS/DEL below 3.75V to force EAOUT low. The 5VUVL comparator has an OK threshold of 4.36V ensuring adequate gate drive voltage is present and a fault threshold of 4.17V.

### Power Good Output

The PWRGD pin is an open-collector output and should be pulled up to a voltage source through a resistor. During soft start, the PWRGD remains low until the output voltage is in regulation and SS/DEL is above 3.75V. The PWRGD pin becomes low if the fault latch is set. A high level at the PWRGD pin indicates that the converter is in operation and has no fault, but does not ensure the output voltage is within the specification. Output voltage regulation within the design limits can logically be assured however, assuming no component failure in the system.

### Tri-State Gate Drivers

The GATELX drivers can pull down up to 3.5A peak current and source up to 1.5A. The GATEHX drivers can source and sink up to 1.5A peak current. An adaptive non-overlap circuit monitors the voltage on the GATEHX and GATELX pins to prevent MOSFET shoot-through current while minimizing body diode conduction.

The Error Amplifier output of the Control IC drives low in response to any fault condition such as VCC input under voltage or output overload. The 0% duty cycle comparator detects this and drives both gate outputs low. This tri-state operation prevents negative inductor current and negative output voltage during power-down.

The Gate Drivers revert to a high impedance "off" state at VCCLX and VCCHX supply voltages below the normal operating range. An 80k $\Omega$  resistor is connected across the GATEX and PGNDX pins to prevent the GATEX voltage from rising due to leakage or other cause under these conditions.

### Over Voltage Protection (OVP)

The output Over-Voltage Protection comparator monitors the output voltage through the OVPSNS pin, the positive remote sense point. If OVPSNS exceeds VDAC plus 150mV (for VR-10.0, 450mV for OPTERON and ATHLON, selected with the VID\_SEL pin), both GATEL pins drive high and the OVP pin sources 75 $\mu$ A current. The OVP circuit over-rides the normal PWM operation and will fully turn-on the low side MOSFET within approximately 150ns. The low side MOSFET will remain ON until the over-voltage condition ceases. The lower MOSFETs alone can not clamp the output voltage however an SCR or N-MOSFET could be triggered with the OVP pin to prevent processor damage.

In the event of a high side MOSFET short, the OVP flag is activated with as little supply voltage as possible. The OVPSNS pin is compared against both VCC and 5VUVL for OVP conditions at power-up. VCC is monitored for conversion off 12V, 5VUVL is monitored for conversion off 5V. The OVP pin flags a voltage greater than 0.5V with supply voltages as low as 1.0V. This headroom voltage varies inversely with temperature. An external comparator can be used to disable the silver box, activate a crowbar, or supply source.

The overall system must be considered when designing for OVP. In many cases the over-current protection of the AC-DC or DC-DC converter supplying the multiphase converter will be triggered thus providing effective protection without damage as long as all PCB traces and components are sized to handle the worst-case maximum current. If this is not possible, a fuse can be added in the input supply to the multiphase converter.

A Body Braking™ Disable Comparator has been included to prevent false OVP firing during dynamic VID down changes. The BB DISABLE Comparator disables Body Braking™ when FB exceeds VDAC by 75mV. The low side MOSFETs will then be controlled to keep V(FB) and V(VOUT) within 80mV of V(VDAC), below the 150mV INTEL OVP trip point.

**APPLICATIONS INFORMATION**

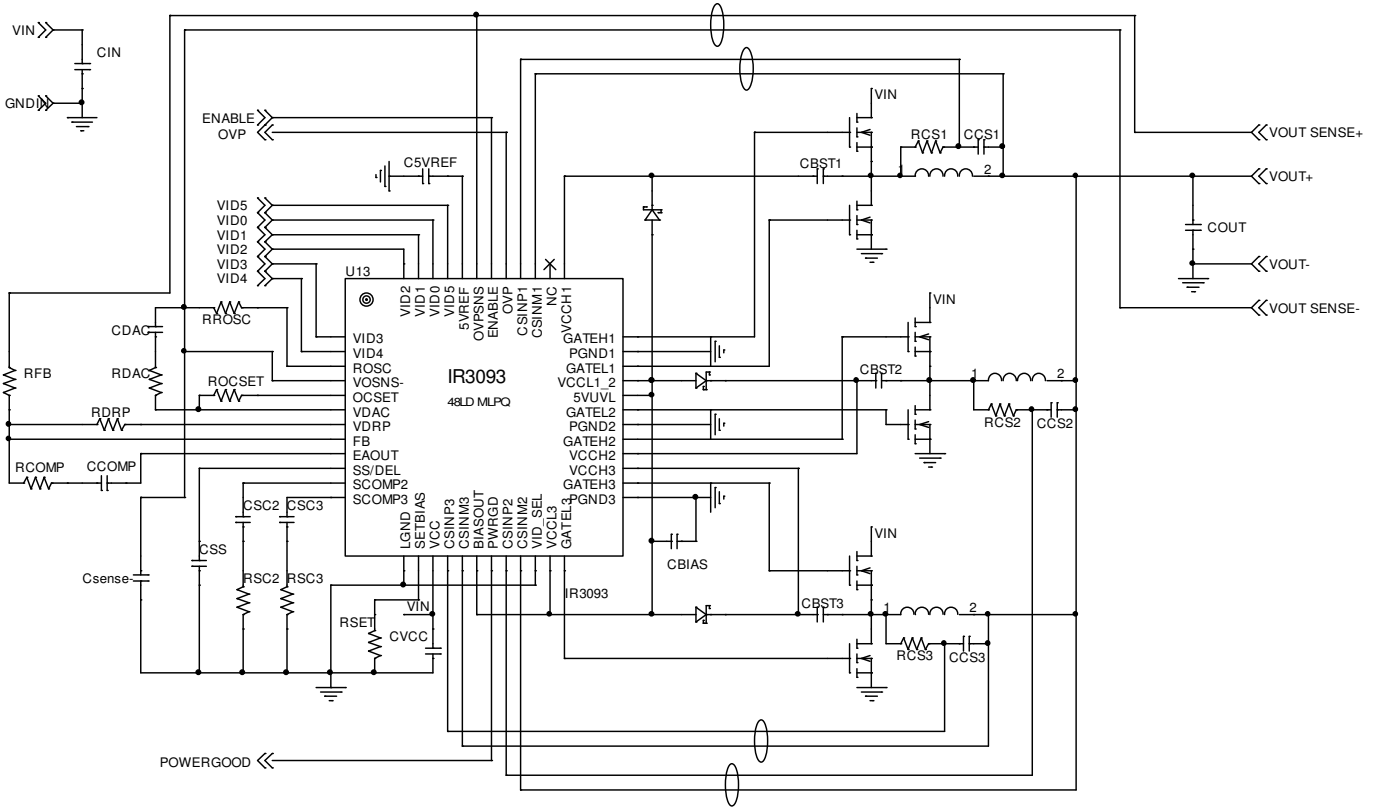

**Figure 6 – System Diagram**

**VID Control**

The IR3093 provides three different microprocessor solutions. The VID\_SEL pin selects the appropriate Digital-to-Analog Converters (DAC), VID threshold voltages, and Over Voltage Protection (OVP) threshold for either VR-10.0, OPTERON, or ATHLON solutions. Reference voltages are shown in Table 1. The DAC output voltage is available at the VDAC pin. A detailed block diagram of the VID control circuitry can be found in Figure 7. The VID pins are internally pulled up to 4.9V by 18uA current sources. The VID input comparators have a 0.6V threshold for VR-10.0 or 1.65V threshold for OPTERON and ATHLON. The selected DAC voltage is provided at the Error Amplifier positive input and to the VDAC pin by the trans-conductance DAC Buffer.

The VDAC voltage is trimmed to the Error Amplifier output voltage with EAOUT tied to FB via an accurate resistor. This compensates DAC Buffer input offset, Error Amplifier input offset, and errors in the generation of the FB bias current which is based on  $R_{ROSC}$ . This trim method provides a 0.5% system accuracy.

The IR3093 can accept changes in the VID code while operating and vary the VDAC voltage accordingly. The IR3093 detects a VID change and blanks the DAC output response for 400ns to verify the new code is valid and not due to skew or noise. The sink/source capability of the VDAC buffer amp is programmed by the same external resistor that sets the oscillator frequency,  $R_{ROSC}$ . The slew rate of the voltage at the VDAC pin can be adjusted by an external capacitor between VDAC pin and the VOSNS- pin. A resistor connected in series with this capacitor is

required to compensate the VDAC buffer amplifier. Digital VID transitions result in a smooth analog transition of the VDAC voltage and converter output voltage minimizing inrush currents in the input and output capacitors and overshoot of the output voltage.

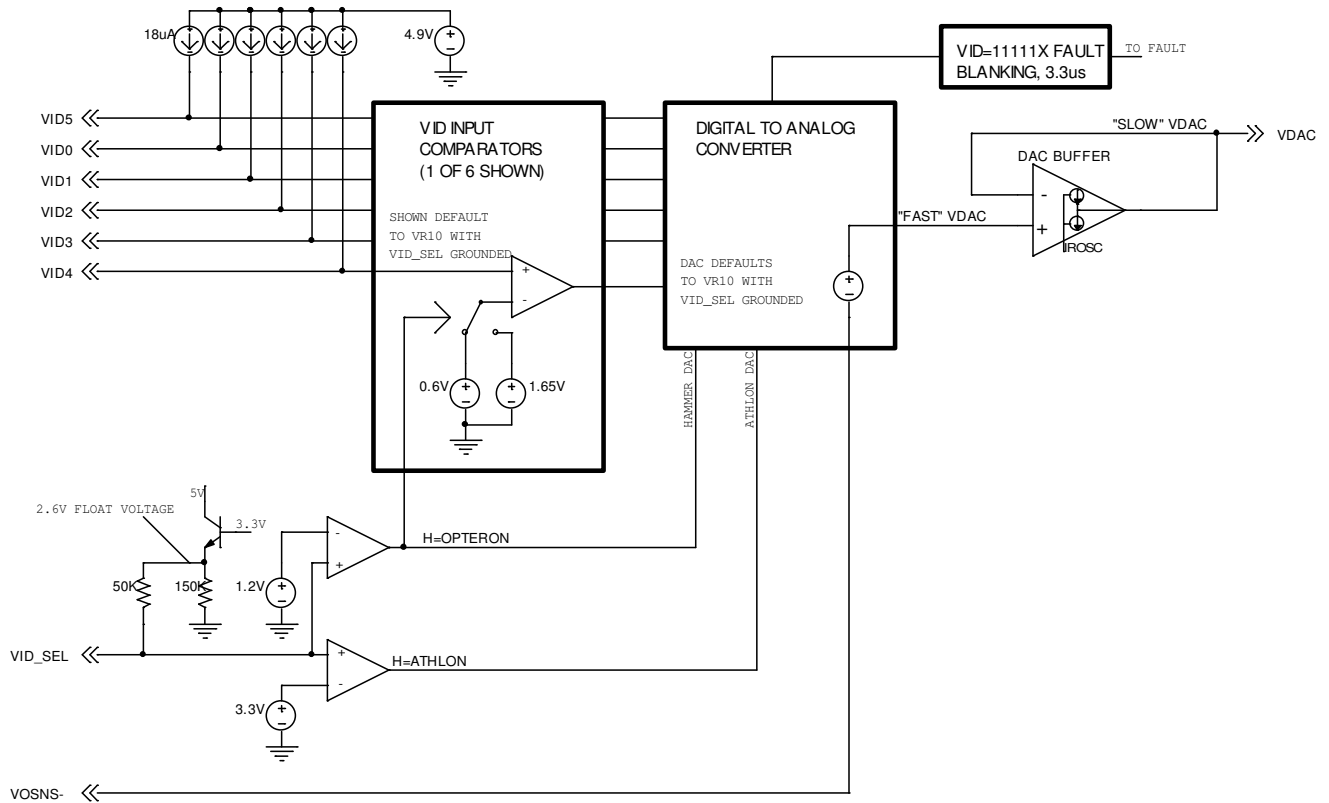

**Figure 7– VID Control Block Diagram**

**VID = 11111X Fault**

VID codes of 111111 and 111110 will set the fault latch and disable the Error Amplifier once SS/DEL is below 3.75V.

AMD Opteron VID Table						AMD ATHLON VID Table						
VID_SEL Open. V(VDAC) is pre-positioned 50mV higher than Vout values listed below for load positioning.						VIDSEL to VCC. V(VDAC) is pre-positioned 50mV higher than Vout values listed below for load positioning.						
Vout is measured at EAOUT with ROSC=47K and a 1890 ohm resistor connecting FB to EAOUT to cancel the 50mV pre-position offset.						Vout is measured at EAOUT with ROSC=47K and a 1890 ohm resistor connecting FB to EAOUT to cancel the 50mV pre-position offset.						
VID4	VID3	VID2	VID1	VID0	Vout (V)	VID4	VID3	VID2	VID1	VID0	Vout (V)	
0	0	0	0	0	1.550	0	0	0	0	0	1.850	
0	0	0	0	1	1.525	0	0	0	0	1	1.825	
0	0	0	1	0	1.500	0	0	0	1	0	1.800	
0	0	0	1	1	1.475	0	0	0	1	1	1.775	
0	0	1	0	0	1.450	0	0	1	0	0	1.750	
0	0	1	0	1	1.425	0	0	1	0	1	1.725	
0	0	1	1	0	1.400	0	0	1	1	0	1.700	
0	0	1	1	1	1.375	0	0	1	1	1	1.675	
0	1	0	0	0	1.350	0	1	0	0	0	1.650	
0	1	0	0	1	1.325	0	1	0	0	1	1.625	
0	1	0	1	0	1.300	0	1	0	1	0	1.600	
0	1	0	1	1	1.275	0	1	0	1	1	1.575	
0	1	1	0	0	1.250	0	1	1	0	0	1.550	
0	1	1	0	1	1.225	0	1	1	0	1	1.525	
0	1	1	1	0	1.200	0	1	1	1	0	1.500	
0	1	1	1	1	1.175	0	1	1	1	1	1.475	
1	0	0	0	0	1.150	1	0	0	0	0	1.450	
1	0	0	0	1	1.125	1	0	0	0	1	1.425	
1	0	0	1	0	1.100	1	0	0	1	0	1.400	
1	0	0	1	1	1.075	1	0	0	1	1	1.375	
1	0	1	0	0	1.050	1	0	1	0	0	1.350	
1	0	1	0	1	1.025	1	0	1	0	1	1.325	
1	0	1	1	0	1.000	1	0	1	1	0	1.300	
1	0	1	1	1	0.975	1	0	1	1	1	1.275	
1	1	0	0	0	0.950	1	1	0	0	0	1.250	
1	1	0	0	1	0.925	1	1	0	0	1	1.225	
1	1	0	1	0	0.900	1	1	0	1	0	1.200	
1	1	0	1	1	0.875	1	1	0	1	1	1.175	
1	1	1	0	0	0.850	1	1	1	0	0	1.150	
1	1	1	0	1	0.825	1	1	1	0	1	1.125	
1	1	1	1	0	0.800	1	1	1	1	0	1.100	
1	1	1	1	1	OFF <sup>4</sup>	1	1	1	1	1	OFF <sup>4</sup>	

Note: 4 Output disabled (Fault mode)

Table 1 - Voltage Identification (VID)

**INTEL VR-10.0 VID Table (VID\_SEL Grounded, measured at EAOUT=FB.)**

Processor Pins (0 = low, 1 = high)						Vout (V)	Processor Pins (0 = low, 1 = high)						Vout (V)
VID4	VID3	VID2	VID1	VID0	VID5		VID4	VID3	VID2	VID1	VID0	VID5	
0	1	0	1	0	0	0.8375	1	1	0	1	0	0	1.2125
0	1	0	0	1	1	0.8500	1	1	0	0	1	1	1.2250
0	1	0	0	1	0	0.8625	1	1	0	0	1	0	1.2375
0	1	0	0	0	1	0.8750	1	1	0	0	0	1	1.2500
0	1	0	0	0	0	0.8875	1	1	0	0	0	0	1.2625
0	0	1	1	1	1	0.9000	1	0	1	1	1	1	1.2750
0	0	1	1	1	0	0.9125	1	0	1	1	1	0	1.2875
0	0	1	1	0	1	0.9250	1	0	1	1	0	1	1.3000
0	0	1	1	0	0	0.9375	1	0	1	1	0	0	1.3125
0	0	1	0	1	1	0.9500	1	0	1	0	1	1	1.3250
0	0	1	0	1	0	0.9625	1	0	1	0	1	0	1.3375
0	0	1	0	0	1	0.9750	1	0	1	0	0	1	1.3500
0	0	1	0	0	0	0.9875	1	0	1	0	0	0	1.3625
0	0	0	1	1	1	1.0000	1	0	0	1	1	1	1.3750
0	0	0	1	1	0	1.0125	1	0	0	1	1	0	1.3875
0	0	0	1	0	1	1.0250	1	0	0	1	0	1	1.4000
0	0	0	1	0	0	1.0375	1	0	0	1	0	0	1.4125
0	0	0	0	1	1	1.0500	1	0	0	0	1	1	1.4250
0	0	0	0	1	0	1.0625	1	0	0	0	1	0	1.4375
0	0	0	0	0	1	1.0750	1	0	0	0	0	1	1.4500
0	0	0	0	0	0	1.0875	1	0	0	0	0	0	1.4625
1	1	1	1	1	1	OFF <sup>4</sup>	0	1	1	1	1	1	1.4750
1	1	1	1	1	0	OFF <sup>4</sup>	0	1	1	1	1	0	1.4875
1	1	1	1	0	1	1.1000	0	1	1	1	0	1	1.5000
1	1	1	1	0	0	1.1125	0	1	1	1	0	0	1.5125
1	1	1	0	1	1	1.1250	0	1	1	0	1	1	1.5250
1	1	1	0	1	0	1.1375	0	1	1	0	1	0	1.5375
1	1	1	0	0	1	1.1500	0	1	1	0	0	1	1.5500
1	1	1	0	0	0	1.1625	0	1	1	0	0	0	1.5625
1	1	0	1	1	1	1.1750	0	1	0	1	1	1	1.5750
1	1	0	1	1	0	1.1875	0	1	0	1	1	0	1.5875
1	1	0	1	0	1	1.2000	0	1	0	1	0	1	1.6000

Note: 4. Output disabled (Fault mode)

**Table 1 Continued - Voltage Identification (VID)**

**Slew Rate Programming Capacitor CDAC and Resistor RDAC**

VDAC sink current ISINK and source current ISOURCE are determined by RROSC, and their value can be found using the curve in this data sheet. The slew rate of VDAC down-slope SRDOWN can be programmed by the external capacitor CDAC as defined in Equation (1) and shown in Figure1. Resistor RDAC is used to compensate VDAC circuit and is determined by Equation (2). The slew rate of VDAC up-slope SRUP is proportional to the down-slope slew rate SRDOWN and is given by Equation (3).

$$C_{DAC} = \frac{I_{SINK}}{SR_{DOWN}} \quad (1)$$

$$R_{DAC} = 0.5 + \frac{3.2 * 10^{-15}}{C_{DAC}^2} \quad (2)$$

$$SR_{UP} = \frac{I_{SOURCE}}{C_{DAC}} \quad (3)$$

### Oscillator Resistor $R_{ROSC}$

The oscillator frequency is programmable from 100kHz to 540kHz with an external resistor  $R_{ROSC}$  as shown in Figure 6 oscillator generates an internal 50% duty cycle sawtooth signal (Figure 3.) that is used to generate 120° out-of-phase timing pulses to set Phase 1,2 and 3 RS flip-flops. Once the switching frequency is chosen,  $R_{ROSC}$  can be determined from the curve in the Typical Operating Characteristics Section.

### Soft Start, Over-Current Fault Delay, and Hiccup Mode

The IR3093 has a programmable soft-start function to limit the surge current during converter power-up. A capacitor connected between the SS/DEL and LGND pins controls soft start timing as well as over-current protection delay and hiccup mode timing.

Figure 8 depicts the various operating modes of the SS/DEL function. Under a no fault condition, the SS/DEL capacitor will charge. The SS/DEL charge soft-start duration is controlled by a 60uA charge current which charges CSS up to 4.0V. The Error Amplifier output is clamped low until SS/DEL reaches 1.1V. The Error Amplifier will then regulate the converter's output voltage to match the SS/DEL voltage less the 1.1V offset until it reaches the level determined by the VID inputs. The PWRGD signal is asserted once the SS/DEL voltage exceeds 3.75V.

Five different faults will immediately cause SS/DEL to begin discharging and set the Fault Latch once SS/DEL is below 3.75V;

1. VCC Under Voltage Lock Out
2. 5VUVL Under Voltage Lock Out
3. VID=11111x fault
4. Low Enable pin
5. Over Current Condition.

A delay is included if any fault condition occurs after a successful soft start sequence. This is required since momentary faults can occur as part of normal operation due to load transients such as exciting an over-current condition or a VID=11111x code while going through VID transitions. If any fault occurs during normal operation, the SS/DEL capacitor will discharge through a 55uA current sink but will not set the fault latch immediately. If the fault condition persists long enough for the SS/DEL capacitor to discharge below the 3.75V threshold of the delay comparator, the Fault latch will be set pulling the Error Amplifier's output low, inhibiting switching and de-asserting the PWRGD signal. The SS/DEL capacitor is then discharged through a 6uA discharge current resulting in a long hiccup duration.

The SS/DEL capacitor will continue to discharge until it reaches 0.265V where the fault latch is reset allowing a normal soft start to occur. If a fault condition is again encountered during the soft start cycle, the fault latch will be set without any delay and hiccup mode will begin. During hiccup mode the 10 to 1 charge to discharge ratio results in a 9.1% hiccup mode duty cycle regardless of at what point a fault condition occurs.

The converter can be disabled if the SS/DEL pin is pulled below 0.9V.

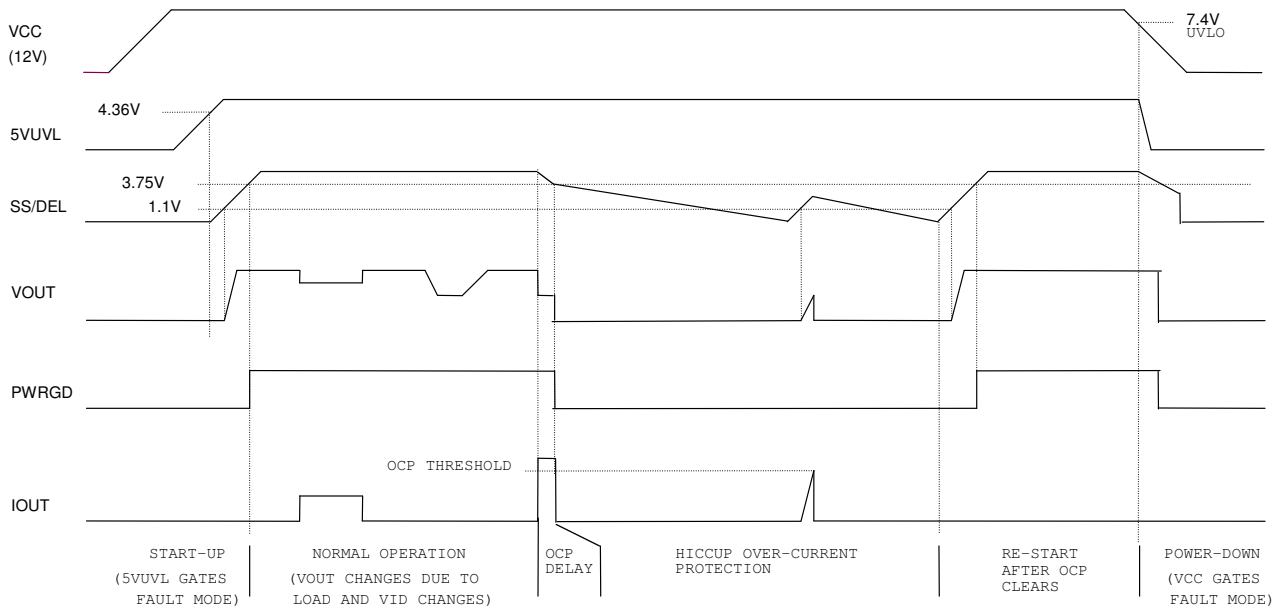

**Figure 8 – Operating Waveforms**

Soft-start delay time  $t_{SSDEL}$  is the time SS/DEL charged up to 1.1V. After that the error amplifier output is released to allow the soft start. The soft start time  $t_{SS}$  represents the time during which converter output voltage rises from zero to  $V_O$ .  $t_{SS}$  can be programmed by  $C_{SS}$  using equation (4).

$$C_{SS} = \frac{I_{CHG} * t_{SS}}{V_O} = \frac{60 * 10^{-6} * t_{SS}}{V_O} \quad (4)$$

Once  $C_{SS}$  is chosen, the soft start delay time  $t_{SSDEL}$ , the over-current fault latch delay time  $t_{OCDEL}$ , and the delay time  $t_{VccPG}$  from output voltage ( $V_O$ ) in regulation to Power Good are fixed and shown in equation (5), (6) and (7) respectively.

$$t_{SSDEL} = \frac{C_{SS} * \Delta V}{I_{CHG}} = \frac{C_{SS} * 1.1}{60 * 10^{-6}} \quad (5)$$

$$t_{OCDEL} = \frac{C_{SS} * \Delta V}{I_{DISCHG}} = \frac{C_{SS} * 0.25}{61 * 10^{-6}} \quad (6)$$

$$t_{VccPG} = \frac{C_{SS} * \Delta V}{I_{CHG}} = \frac{C_{SS} * (3.75 - V_O - 1.1)}{60 * 10^{-6}} \quad (7)$$

### Over Current Protection (OCP)

The current limit threshold is set by a resistor connected between the OCSET and VDAC pins. If the average Current Sense Amplifier output plus VDAC voltage exceeds the OCSET voltage, the over-current protection is triggered.

A delay is included if an over-current condition occurs after a successful soft-start sequence. This is required since over-current conditions can occur as part of normal operation due to load transients or VID transitions. If an over-current fault occurs during normal operation, the Over Current Comparator will initiate the discharge of the capacitor at SS/DEL but will not set the fault latch immediately. If the over-current condition persists long enough for the SS/DEL capacitor to discharge below the 250mV offset of the delay comparator, the Fault latch will be set pulling the Error Amplifier's output low inhibiting switching in the phase ICs and de-asserting the PWRGD signal. See Soft Start, Over-Current Fault Delay, and Hiccup Mode. The hiccup mode duty cycle of over current protection is determined by the ratio of the charge to discharge current and is fixed at 9.1% for the ratio of 10 to 1.

The inductor DC resistance  $R_L$  is utilized to sense the inductor current. The current limit threshold is set by a resistor  $R_{OCSET}$  connected between the OCSET and VDAC pins, as shown in Fig1.  $I_{LIMIT}$  is the required over current limit.  $I_{OCSET}$ , the bias current of OCSET pin, is set by  $R_{ROSC}$  and is determined by the curve in this data sheet. OCP need to satisfy the high temperature condition.  $R_{L\_MAX}$  and  $R_{L\_ROOM}$  are the inductor DCR at maximum temperature  $T_{L\_MAX}$  and room temperature  $T_{ROOM}$  respectively, the maximum inductor DCR can be calculated from Equation (8)

$$R_{L\_MAX} = R_{L\_ROOM} * [1 + 3850 * 10^{-6} * (T_{L\_MAX} - T_{ROOM})] \quad (8)$$

The current sense amplifier gain of IR3093 decreases with temperature at the rate of 1400 PPM, which compensates part of the inductor DCR increase. The minimum current sense amplifier gain at the maximum IC temperature  $T_{IC\_MAX}$  is calculated from Equation (9).

$$G_{CS\_MIN} = G_{CS\_ROOM} * [1 - 1400 * 10^{-6} * (T_{IC\_MAX} - T_{ROOM})] \quad (9)$$

$R_{OCSET}$  can be calculated by the following equation (10), where  $\Delta I$  is the ripple current in each output inductor.

$$R_{OCSET} = \left[ \left( \frac{I_{LIMIT}}{3} + \frac{\Delta I}{2} \right) * R_{L\_MAX} \right] * G_{CS\_MIN} / I_{OCSET} \quad (10)$$

$$\Delta I = \frac{V_o * (V_{in} - V_o)}{L * V_{in} * f_{sw}} \quad (11)$$

### Adaptive Voltage Positioning

Adaptive voltage positioning is needed to reduce output voltage deviations during load transients and power dissipation of the load when it is drawing maximum current. The circuitry related to voltage positioning is shown in Figure 8. Resistor  $R_{FB}$  is connected between the Error Amplifier's inverting input pin FB and the converter's output voltage. An internal current source whose value is programmed by the same external resistor that programs the oscillator frequency,  $R_{ROSC}$ , pumps current out of the FB pin. The FB bias current develops a positioning voltage drop across  $R_{FB}$  which forces the converter's output voltage lower to  $V(VDAC) - I(FB) * R_{FB}$  to maintain a balance at the Error Amplifier inputs.  $R_{FB}$  is selected to program the desired amount of fixed offset voltage below the DAC voltage.

The voltage at the VDRP pin is an average of three phase Current Sense Amplifiers and represents the sum of the VDAC voltage and the average inductor current of all the phases. The VDRP pin is connected to the FB pin through the resistor. The Error Amplifier forces the voltage on the FB pin to equal VDAC through the power supply loop therefore the current through RDRP is equal to  $(VDRP - VDAC) / RDRP$ . As the load current increases, the VDRP voltage increases accordingly which results in an increase  $R_{FB}$  current, further positioning the output regulated voltage lower thus making the output voltage reduction proportional to an increase in load current. The droop impedance or output impedance of the converter can thus be programmed by the resistor RDRP. The offset and slope of the converter output impedance are independent of the VDAC voltage.



$$R_{DRP} = \frac{R_{FB} * R_{L\_MAX} * G_{CS\_MIN}}{n * R_O} \quad (13)$$

### Lossless Average Inductor Current Sensing

Inductor current can be sensed by connecting a series resistor and a capacitor network in parallel with the inductor and measuring the voltage across the capacitor. The equation of the sensing network is,

$$v_C(s) = v_L(s) \frac{1}{1 + sR_S C_S} = i_L(s) \frac{R_L + sL}{1 + sR_S C_S}$$

Usually the resistor  $R_{CS}$  and capacitor  $C_{CS}$  are chosen so that the time constant of  $R_{CS}$  and  $C_{CS}$  equals the time constant of the inductor which is the inductance  $L$  over the inductor DCR. If the two time constants match, the voltage across  $C_{CS}$  is proportional to the current through  $L$ , and the sense circuit can be treated as if only a sense resistor with the value of  $R_L$  was used. The mismatch of the time constants does not affect the measurement of inductor DC current, but affects the AC component of the inductor current.

The advantage of sensing the inductor current versus high side or low side sensing is that actual output current being delivered to the load is obtained rather than peak or sampled information about the switch currents. The output voltage can be positioned to meet a load line based on real time information. Except for a sense resistor in series with the inductor, this is the only sense method that can support a single cycle transient response. Other methods provide no information during either load increase (low side sensing) or load decrease (high side sensing).

An additional problem associated with peak or valley current mode control for voltage positioning is that they suffer from peak-to-average errors. These errors will show in many ways but one example is the effect of frequency variation. If the frequency of a particular unit is 10% low, the peak to peak inductor current will be 10% larger and the output impedance of the converter will drop by about 10%. Variations in inductance, current sense amplifier bandwidth, PWM prop delay, any added slope compensation, input voltage, and output voltage are all additional sources of peak-to-average errors.

Measure the inductance  $L$  and the inductor DC resistance  $R_L$ . Pre-select the capacitor  $C_{CS}$  and calculate  $R_{CSX}$  as follows.

$$R_{CSX} = \frac{L/R_L}{C_{CS}} \quad (14)$$

### Inductor DCR Temperature Correction

If the Current Sense Amplifier temperature dependent gain is not adequate to compensate the inductor DCR TC, a negative temperature coefficient (NTC) thermistor can be added. The thermistor should be placed close to the inductor and connected in parallel with the feedback resistor, as shown in Figure 9. The resistor in series with the thermistor is used to reduce the nonlinearity of the thermistor.

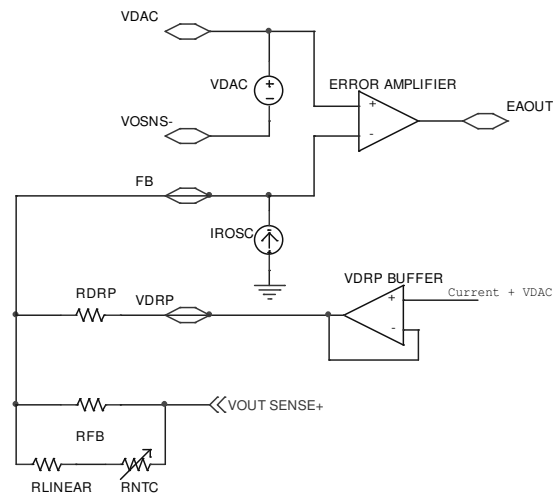

Figure 10 - Temperature compensation of inductor DCR

### Remote Voltage Sensing

To compensate for impedance in the ground plane, the VOSNS- pin is used for remote sensing and connects directly to the load. The VDAC voltage is referenced to VOSNS- to avoid additional error terms or delay related to a separate differential amplifier. The capacitor connecting the VDAC and VOSNS- pins ensure that high speed transients are fed directly into the Error Amplifier without delay.

### Master-Slave Current Share Loop

Current sharing between phases of the converter is achieved by a Master-Slave current share loop topology. The output of the Phase 1 Current Sense Amplifier sets the reference for the Share Adjust Error Amplifiers. Each Share Adjust Error Amplifier adjusts the duty cycle of its respective PWM Ramp and to force its input error to zero compared to the master Phase 1, resulting in accurate current sharing.

The maximum and minimum duty cycle adjust range of Ramps 2 & 3 compared to Ramp1 has been limited to a minimum of 0.5x and a maximum of 2.0x typical (see Figure 3.). The crossover frequency of the current share loop can be programmed with a capacitor at the SCOMPX pin so that the share loop does not interact with the output voltage loop.

The SCOMPX capacitor is driven by a trans-conductance stage capable of sourcing and sinking 22uA. The duty cycle of Ramps 2 & 3 inversely tracks the voltage on their SCOMPX pin; if V(SCOMP2) increases, Ramp2's slope will increase and the effective duty cycle will decrease resulting in a reduction in Phase 2's output current. Due to the limited 22uA source current, an SCOMPX pre-charge circuit has been included to pre-condition V(SCOMPX) so that the duty cycle of Ramps 2 & 3 are equal to Ramp1 prior to any GATEHX high pulses. The pre-condition circuit can source 450uA. The Equal Duty Cycle Comparator (see Block Diagram) activates a pre-charge circuit when SS/DEL is less than 0.6V. The Error Amplifier becomes active enabling GATEH switching when SS/DEL is above 1.1V.

### Set BIASOUT voltage

BIASOUT pin provides 150mA open-looped regulated voltage for GATE drive bias, and the voltage is set by SETBIAS through an external resistor Rset connecting between SETBIAS pin and ground. Bias current  $I_{SETBIAS}$  is a function of ROSC. Rset is chosen by equation (15). VFD in the equation is the forward voltage drop across the Bootstrap diode.

$$R_{SET} = \frac{V_{BIASOUT} + V_{FD}}{I_{SETBIAS}} \quad (15)$$

### Compensation of the Current Share Loop

The crossover frequency of the current share loop should be at least one decade lower than that of the voltage loop in order to eliminate the interaction between the two loops. A 22nF capacitor from SCOMP to LGND is good for most of the applications. If necessary have a 1k resistor in series with the Csc to make the current loop a little bit faster.

### Compensation of Voltage Loop

The adaptive voltage positioning is used in the computer applications to meet the load line requirements. Like current mode control, the adaptive voltage positioning loop introduces extra zero to the voltage loop and splits the double poles of the power stage, which make the voltage loop compensation much easier.

Resistors RFB and RDRP are chosen according to Equations (12) and (13), and the selection of compensation types depends on the capacitors used. For the applications using Electrolytic, Polymer or AL-Polymer capacitors, type II compensation shown in Figure 11 (a) is usually enough. While for the applications with only low ESR ceramic capacitors, type III compensation shown in Figure 11 (b) is preferred.

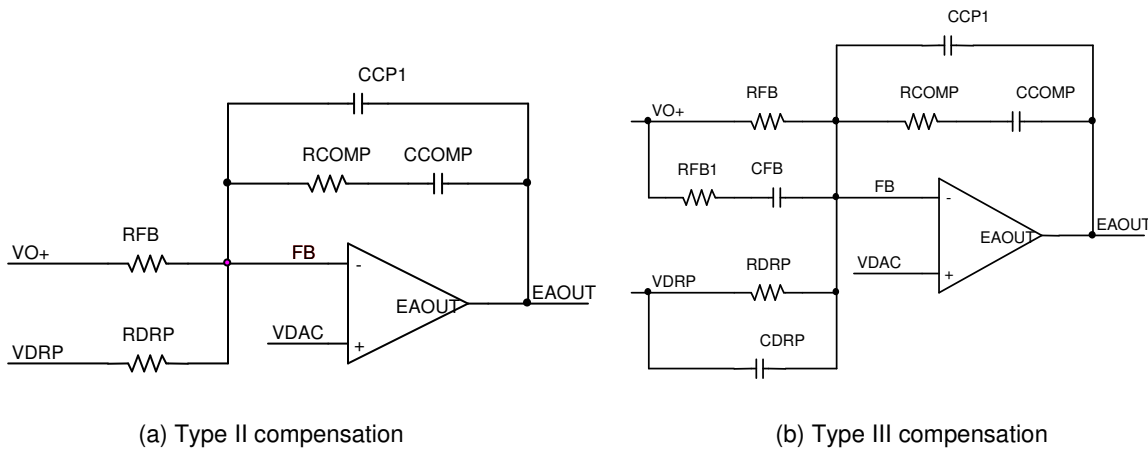

Figure 11 . Voltage loop compensation network

### Type II Compensation

Determine the compensation at no load, the worst case condition. Assume the time constant of the resistor and capacitor across the output inductors matches that of the inductor, the crossover frequency of the voltage loop can be estimated by Equations (16), where  $C_E$  and  $R_{CE}$  are the equivalent capacitance and ESR of output capacitors respectively and  $R_{LE}$  is the equivalent resistance of inductor DCR.

$$f_c = \frac{R_{DRP}}{2\pi * C_E * (G_{CS} * R_{FB} * R_{LE} - R_{CE})} \quad (16)$$

RCOMP and CCOMP have limited effect on the crossover frequency, and are used only to fine tune the crossover frequency and transient load response. Choose the desired crossover frequency  $f_{c1}$  around  $f_c$  estimated by Equation (16) and determine RCOMP and CCOMP.

$$R_{COMP} = \frac{(2\pi * f_{C1})^2 * L_E * C_E * R_{FB}}{V_{IN} * F_M} \quad (17)$$

$$C_{COMP} = \frac{10 * \sqrt{L_E * C_E}}{R_{COMP}} \quad (18)$$

CCP1 is optional and may be needed in some applications to reduce the jitter caused by the high frequency noise. A ceramic capacitor between 10pF and 220pF is usually enough. In equation (17),  $V_{IN}$  is the input voltage,  $F_M$  is the PWM comparator gain (refer to equation (25)).

### Type III Compensation

Determine the compensation at no load, the worst case condition. Assume the time constant of the resistor and capacitor across the output inductors matches that of the inductor, the crossover frequency of the voltage loop can be estimated by Equations (19).

$$f_C = \frac{R_{DRP}}{2\pi * C_E * G_{CS} * R_{FB} * R_{LE}} \quad (19)$$

Choose the desired crossover frequency  $f_{c1}$  around  $f_C$  estimated by Equation (19). Select other components to ensure the slope of close loop gain is -20dB/Dec around the crossover frequency. Choose resistor  $R_{FB1}$  according to Equation (20), and determine  $C_{FB}$  and  $C_{DRP}$  from Equations (21) and (22).

$$R_{FB1} = \frac{1}{2} R_{FB} \quad \text{to} \quad R_{FB1} = \frac{2}{3} R_{FB} \quad (20)$$

$$C_{FB} = \frac{1}{4\pi * f_{C1} * R_{FB1}} \quad (21)$$

$$C_{DRP} = \frac{(R_{FB} + R_{FB1}) * C_{FB}}{R_{DRP}} \quad (22)$$

$R_{COMP}$  and  $C_{COMP}$  have limited effect on the crossover frequency, and are used only to fine tune the crossover frequency and transient load response. Determine  $R_{COMP}$  and  $C_{COMP}$  from Equations (23) and (24), where  $F_M$  is the PWM comparator gain defined by Equation (25).

$$R_{COMP} = \frac{(2\pi * f_{C1})^2 * L_E * C_E * R_{FB}}{V_I * F_M} \quad (23)$$

$$C_{COMP} = \frac{10 * \sqrt{L_E * C_E}}{R_{COMP}} \quad (24)$$

$$F_M = \frac{V_O}{V_I * V_{RAMP}} \quad (25)$$

CCP1 is optional and may be needed in some applications to reduce the jitter caused by the high frequency noise. A ceramic capacitor between 10pF and 220pF is usually enough.

## DESIGN EXAMPLE

### IR3093 Demo Board for VRD10.1 Application

#### Specifications:

Input Voltage:  $V_I=12\text{ V}$   
 DAC Voltage:  $V_{DAC}=1.35\text{ V}$   
 No Load Output Voltage Offset:  $V_{O\_NLOFST}=20\text{ mV}$   
 Output Current:  $I_O=101\text{ A DC}$   
 Output Current Limit set point:  $I_{LIMIT}=130\text{ A}$   
 Output Impedance:  $R_O=1\text{ m}\Omega$   
 VCC Ready to VCC Power Good Delay:  $t_{VCCPG}=0\text{-}10\text{ mS}$   
 Soft Start Time:  $t_{SS}=2\text{ mS}$   
 Dynamic VID Down-Slope Slew Rate:  $SR_{DOWN}=2.5\text{ mV}/\mu\text{S}$

#### Power Stage Design

Control IC: IR3093  
 Phase Number:  $n=3$   
 Switching Frequency:  $f_{sw}=300\text{ kHz}$   
 Output Inductors:  $L=0.25\text{ }\mu\text{H}$ ,  $R_L=0.65\text{ m}\Omega$   
 Output Capacitors:  $C=0.007\text{ F}$ ,  $R_{CE}=0.7\text{ m}\Omega$

#### External Components of IR3093

##### Oscillator Resistor $R_{osc}$

Once the switching frequency is chosen,  $R_{OSC}$  can be determined from the curve in the datasheet of IR3093 data sheet. For switching frequency of 300 kHz per phase, Choose  $R_{OSC}=30\text{ k}\Omega$

##### Soft Start Capacitor $C_{ss}$

Calculate the soft start capacitor from the required soft start time 2mS.

$$C_{SS} = \frac{I_{CHG} * t_{SS}}{V_O} = \frac{60 * 10^{-6} * 2 * 10^{-3}}{1.35 - 20 * 10^{-3}} = 0.09 * 10^{-6} \text{ F} \quad \text{Choose } C_{SS} = 0.1 \text{ }\mu\text{F}$$

With the selected  $C_{ss}$  value, we can calculate the following delay times:

The Over-Current fault latch delay time  $t_{OCDEL}$  will be:

$$t_{OCDEL} = \frac{C_{SS} * \Delta V}{I_{DISCHG}} = \frac{0.1 * 10^{-6} * 0.25}{61 * 10^{-6}} = 0.4\text{ mS}$$

The soft start delay time is

$$t_{SSEDEL} = \frac{C_{SS} * \Delta V}{I_{CHG}} = \frac{0.1 * 10^{-6} * 1.1}{60 * 10^{-6}} = 1.8\text{ mS}$$

The power good delay time is

$$t_{VccPG} = \frac{C_{SS} * \Delta V}{I_{CHG}} = \frac{0.1 * 10^{-6} * (3.75 - 1.33 - 1.1)}{60 * 10^{-6}} = 2.2mS$$

### VDAC Slew Rate Programming Capacitor CDAC and Resistor RDAC

From IR3093 data sheet, the sink current  $I_{SINK}$  of VDAC pin corresponding to  $R_{OSC}=30k\Omega$  is 85uA. Calculate the VDAC down-slope slew-rate programming capacitor from the required down-slope slew rate.

$$C_{VDAC} = \frac{I_{SINK}}{SR_{DOWN}} = \frac{85 * 10^{-6}}{2.5 * 10^{-3} / 10^{-6}} = 34nF$$

Choose  $C_{VDAC} = 33nF$

Calculate the programming resistor.

$$R_{DAC} = 0.5 + \frac{3.2 * 10^{-15}}{C_{DAC}^2} = 0.5 + \frac{3.2 * 10^{-15}}{(33 * 10^{-9})^2} = 3.4\Omega$$

In practice slightly adjust RDAC to get desired slew rate.

### Over Current Setting Resistor ROCSET

According to the spec, the output current limit set point  $I_{LIMIT} = 130A$ . The bias current  $I_{OCSET}$  set by  $R_{ROSC}$  is around 40uA. Assume the maximum temperature  $T_{L\_MAX} = 120$  C, the room temperature  $T_{ROOM}=25$  C, so

$$R_{L\_MAX} = 0.65 * 10^{-3} * [1 + 3850 * 10^{-6} * (120 - 25)] = 0.9m\Omega$$

Assume maximum IC temperature  $T_{IC\_MAX}=110C$ , the minimum current sense amplifier gain can be calculated from Equation (11).

$$G_{CS\_MIN} = 23.5 * [1 - 1400 * 10^{-6} * (110 - 25)] = 21$$

Using Equation (12) and (13) to calculate ROCSET:

$$\Delta I = \frac{V_o * (V_{in} - V_o)}{L * V_{in} * f_{sw}} = \frac{1.33 * (12 - 1.33)}{0.25 * 10^{-6} * 12 * 300 * 10^3} = 15.8 A$$

$$R_{OCSET} = [(\frac{I_{LIMIT}}{3} + \frac{\Delta I}{2}) * R_{L\_MAX}] * G_{CS\_MIN} / I_{OCSET} = [(\frac{130}{3} + \frac{15.8}{2}) * 0.9 * 10^{-3}] * 21 / (40 * 10^{-6}) = 24.2k\Omega$$

Choose ROCSET = 25 k $\Omega$

### No Load Output Voltage Setting Resistor RFB and Adaptive Voltage Positioning Resistor RDRP

The value of the internal current source current  $I_{FB}$  in the curve is 42uA according to  $R_{ROSC} = 30k\Omega$ .

$$R_{FB} = \frac{V_{O\_NLOFST}}{I_{FB}} = \frac{20 * 10^{-3}}{42 * 10^{-6}} = 476\Omega. \quad \text{Choose } R_{FB} = 499\Omega$$

$$R_{DRP} = \frac{R_{FB} * R_{L\_MAX} * G_{CS\_MIN}}{n * R_O} = \frac{499 * 0.9 * 10^{-3} * 21}{3 * 1 * 10^{-3}} = 3.1k\Omega$$

Choose RDRP = 3.09kΩ

### Inductor Current Sensing Capacitor Ccs and Resistors Rcs1 and Rcs2

Choose capacitor Ccs = 0.22uF calculate Rcs1

$$R_{CS1} = \frac{L/R_L}{C_{CS}} = \frac{0.25 * 10^{-6} / 0.65 * 10^{-3}}{0.22 * 10^{-6}} = 1.8k\Omega \quad \text{Choose } R_{CS1} = 2k\Omega$$

### Set BIASOUT voltage Resistor Rset

Bias current  $I_{SETBIAS}$  is around 160uA in this case. Set  $V_{BIASOUT}$  around 8V to be gate drive voltage of MOSFETs.

$$R_{SET} = \frac{V_{BIASOUT} + 0.3}{I_{SETBIAS}} = \frac{8 + 0.3}{160 * 10^{-6}} = 51.9k\Omega$$

Choose RSET=51.1kΩ

### Compensation of Voltage Loop

AL-Polymer output capacitors are used in the design, and the crossover frequency of the voltage loop can be estimated as,

$$f_c = \frac{R_{DRP}}{2\pi * C_E * (G_{CS} * R_{FB} * R_{LE} - R_{CE})} = \frac{3.09 * 10^3}{2\pi * 0.007 * [23.5 * 499 * (0.65 * 10^{-3} / 3) - 0.7 * 10^{-3}]} = 28kHz$$

R<sub>COMP</sub> and C<sub>COMP</sub> are used to fine tune the crossover frequency and transient load response. Choose the desired crossover frequency  $f_{c1}$  (=30kHz) and determine R<sub>COMP</sub> and C<sub>COMP</sub>.

$$F_M = \frac{V_O}{V_I * V_{RAMP}} = \frac{1.33}{12 * 0.63} = 0.18$$

$$R_{COMP} = \frac{(2\pi * f_{c1})^2 * L_E * C_E * R_{FB}}{V_I * F_M} = \frac{(2\pi * 30 * 10^3)^2 * (250 * 10^{-9} / 3) * 0.007 * 499}{12 * 0.18} = 5k\Omega$$

$$C_{COMP} = \frac{10 * \sqrt{L_E * C_E}}{R_{COMP}} = \frac{10 * \sqrt{(250 * 10^{-9} / 3) * 0.007}}{5 * 10^3} = 48nF$$

In practice, adjust R<sub>COMP</sub> and C<sub>COMP</sub> if need to get desired dynamic load response performance.

## MathCAD file to estimate the power dissipation of the IC

this Mathcad file step by step shows how to estimate the power dissipation of IR3093 .

### Initial Conditions:

No.of Phases:  $n := 3$   
 IC Supply Voltage:  $V_{cc} := 12$  (V) , IC Supply Current(quiescent):  $I_{cq} := 38$  (mA)  
 Total High side Driver VCCH supply current(quiescent):  $I_{qh} := 5 \cdot n$  (mA)  
 Total Low side Driver VCCL supply Current(quiescent):  $I_{ql} := 5 \cdot n$  (mA)  
 Biasout Voltage:  $V_{bias} := 7.5$  (V)  
 Switching Frequency per phase:  $f_{sw} := 300$  (kHz)  
 Thermal Impedance of IC:  $\theta_{JA} := 27$  ( $^{\circ}\text{C}/\text{W}$ )

The data from the selected MOSFETs:

Control FET IR6623, Number of Control FET per phase:  $n_c := 1$   
 Control FET total gate charge:  $Q_{gc} := 16$  (nC)  
 Synchronous FET IR6620, Number of sync. FET per phase:  $n_s := 1$   
 Sync FET total gate charge:  $Q_{gs} := 45$  (nC)

### Power Dissipation:

The IC will have less power dissipation if using external gate driver supply. For the worst case estimation, assuming using the bias regulator for all the gate drive supply voltage.

#### 1. Quiescent Power dissipation

Total Quiescent Power Dissipation:

$$P_q := (I_{cq} + I_{qh} + I_{ql}) \cdot V_{cc} \cdot 10^{-3} \quad P_q = 0.816 \text{ (W)}$$

#### 2. The Power Loss to drive the gate of the MOSFETs

With the assumption of the low MOSFET gate resistances, most gate drive losses are dissipated in the driver circuit.

$$P_{drv} := V_{bias} \cdot f_{sw} \cdot 10^3 \cdot n \cdot [(n_c \cdot Q_{gc} + n_s \cdot Q_{gs}) \cdot 10^{-9}] \quad P_{drv} = 0.412 \text{ (W)}$$

Where the  $I_g := f_{sw} \cdot 10^3 \cdot n \cdot (n_c \cdot Q_{gc} + n_s \cdot Q_{gs}) \cdot 10^{-9}$  term in the equation gives the total average bias current required to drive all the MOSFETs.

#### 3. The bias regulator Power Loss to supply driving the MOSFETs

$$P_{reg} := (V_{cc} - V_{bias}) \cdot I_g \quad P_{reg} = 0.247 \text{ (W)}$$

#### 4. Total Power Dissipation of the IC:

$$P_{diss} := P_q + P_{drv} + P_{reg} \quad P_{diss} = 1.475 \text{ (W)}$$

And the total Junction temperature rising is:  $P_{diss} \cdot \theta_{JA} = 39.82$  ( $^{\circ}\text{C}$ )

**APPLICATION CIRCUIT - 3 PHASE OPTERON CONVERTER**

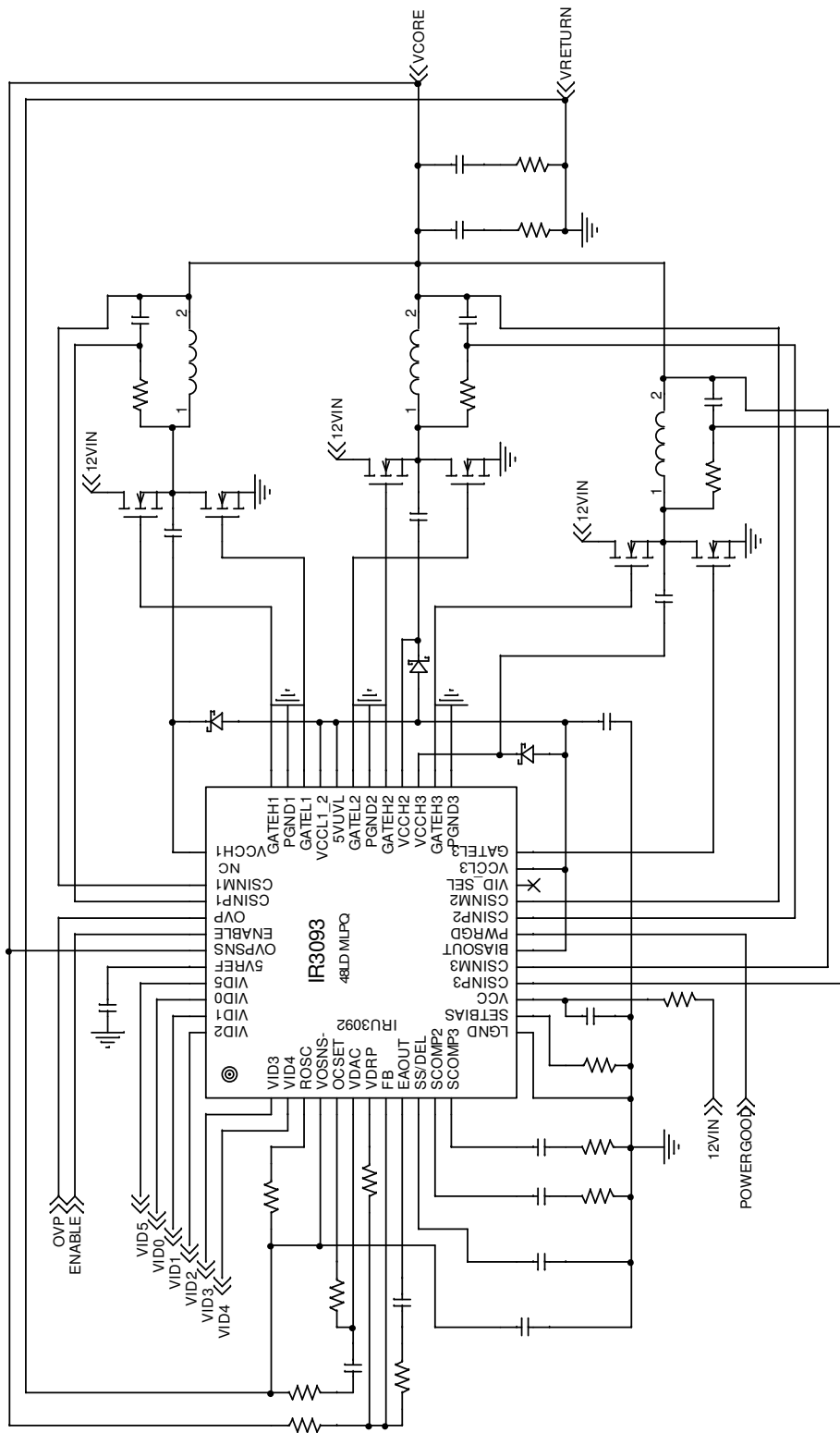

**Figure 12. 12V Control, 12V Power Opteron Converter**

**APPLICATION CIRCUIT - 3 PHASE VR10.X CONVERTER**

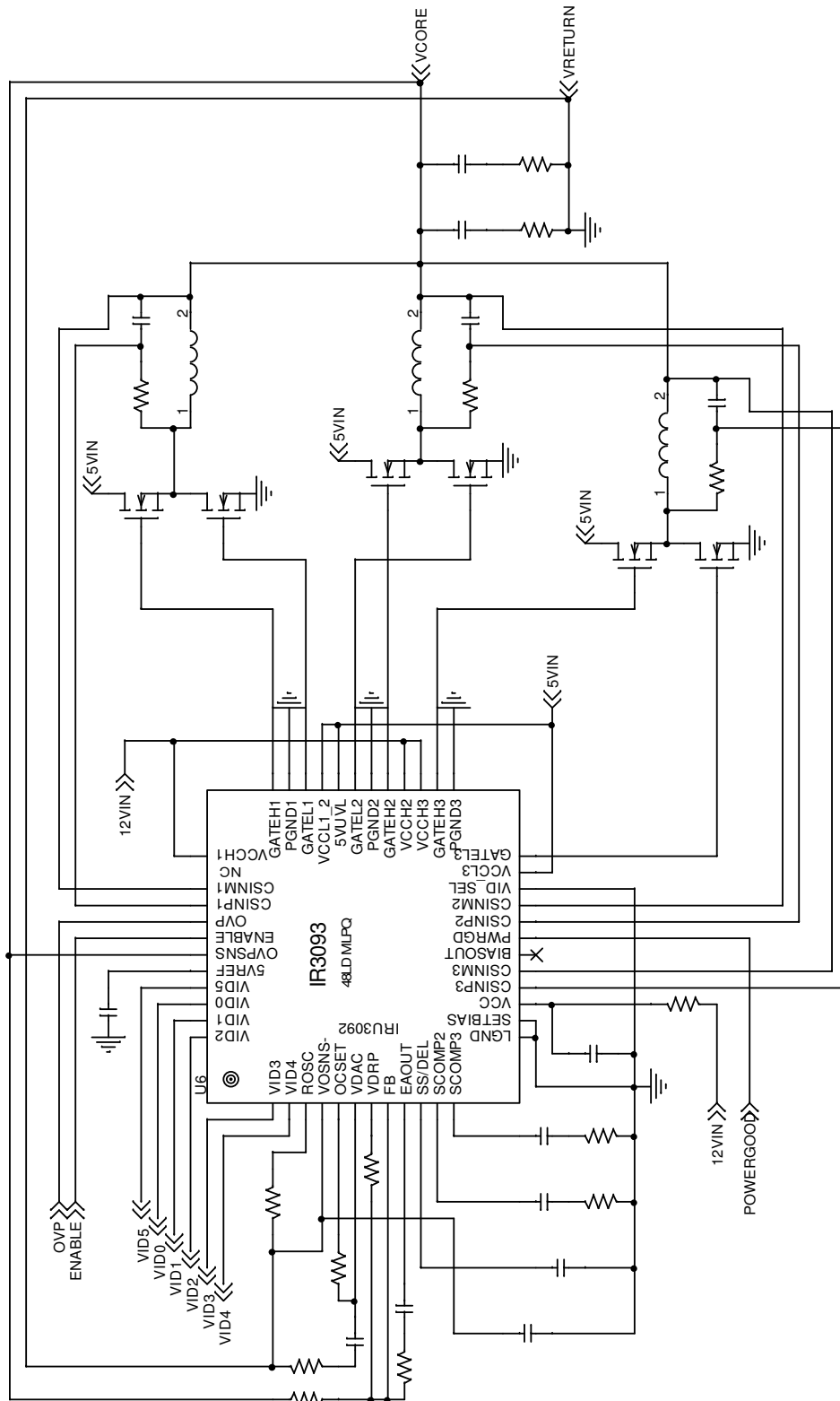

**Figure 13. 12V Control, 5V Power, VR10 Converter**

## LAYOUT GUIDELINES

The following layout guidelines are recommended to reduce the parasitic inductance and resistance of the PCB layout, therefore minimizing the noise coupled to the IC. Refer to the schematic in Figure 6 – System Diagram.

- Dedicate at least one inner layer of the PCB as power ground plane (PGND).
- The center pad of IC must be connected to ground plane (PGND) using the recommended via pattern shown in “Package Dimensions”.
- The IC’s PGND1, 2, 3 and LGND should connect to the center pad under IC.
- The following components must be grounded directly to the LGND pin on the IC using a ground plane on the component side of PCB: CSS, RSC2, RSC3, RSET, CVCC and C5VREF. The LGND should only be connected to ground plan on the center pad under IC
- Place the decoupling capacitors CVCC and CBIAS as close as possible to the VCC and VCCL1\_2, VCCL3 pins. The ground side of CBIAS should not be connected to LGND and it should directly grounded through vias.
- The following components should be placed as close as possible to the respective pins on the IC: RROSC, ROCSET, CDAC, RDAC, CSS, CSC2, RSC2, CSC3, RSC3, RSET.
- Place current sense capacitors CCS1, 2, 3 and resistors RCS1, 2, 3 as close as possible to CSINP1, 2, 3 pins of IC and route the two current sense signals in pairs connecting to the IC. The current sense signals should be located away from gate drive signals and switch nodes.
- Use Kelvin connections to route the current sense traces to each individual phase inductor, in order to achieve good current share between phases.
- Place the input decoupling capacitors closer to the drain of top MOSFET and the source of the bottom MOSFET. If possible, Use multiple smaller value ceramic caps instead of one big cap, or use low inductance type of ceramic cap, to reduce the parasitic inductance.
- Route the high current paths using wide and short traces or polygons. Use multiple vias for connections between layers.
- The symmetry of the following connections from phase to phase is important for proper operation:
  - The Kelvin connections of the current sense signals to inductors.
  - The gate drive signals from the IC to the MOSFETS.
  - The polygon shape of switching nodes.

## PCB AND STENCIL DESIGN METHODOLOGY

- 7x7
- 48 Lead
- 0.5mm pitch MLPQ

See Figures 14-16.

### PCB Metal Design (0.5mm Pitch Leads)

1. Lead land width should be equal to nominal part lead width. The minimum lead to lead spacing should be  $\geq 0.2\text{mm}$  to minimize shorting.
2. Lead land length should be equal to maximum part lead length + 0.2 mm outboard extension + 0.05mm inboard extension. The outboard extension ensures a large and inspectable toe fillet, and the inboard extension will accommodate any part misalignment and ensure a fillet.
3. Center pad land length and width should be = maximum part pad length and width. However, the minimum metal to metal spacing should be  $\geq 0.17\text{mm}$  (2 oz. Copper,  $\geq 0.23\text{mm}$  for 3 oz. Copper and  $\geq 0.1\text{mm}$  for 1 oz. Copper)
4. Sixteen 0.30mm diameter vias shall be placed in the pad land spaced at 1.2mm, and connected to ground to minimize the noise effect on the IC, and to transfer heat to the PCB.

### PCB Solder Resist Design (0.5mm Pitch Leads)

1. Lead lands. The solder resist should be pulled away from the metal lead lands by a minimum of 0.060mm. The solder resist mis-alignment is a maximum of 0.050mm and it is recommended that the lead lands are all NSMD. Therefore pulling the S/R 0.060mm will always ensure NSMD pads.
2. The minimum solder resist width is 0.13mm, therefore it is recommended that the solder resist is completely removed from between the lead lands forming a single opening for each "group" of lead lands.
3. At the inside corner of the solder resist where the lead land groups meet, it is recommended to provide a fillet so a solder resist width of  $\geq 0.17\text{mm}$  remains.
4. Land Pad. The land pad should be SMD, with a minimum overlap of the solder resist onto the copper of 0.060mm to accommodate solder resist mis-alignment. In 0.5mm pitch cases it is allowable to have the solder resist opening for the land pad to be smaller than the part pad.
5. Ensure that the solder resist in-between the lead lands and the pad land is  $\geq 0.15\text{mm}$  due to the high aspect ratio of the solder resist strip separating the lead lands from the pad land.
6. The single via in the land pad should be tented with solder resist 0.4mm diameter, or 0.1mm larger than the diameter of the via.

### Stencil Design (0.5mm Pitch Leads)

1. The stencil apertures for the lead lands should be approximately 80% of the area of the lead lands. Reducing the amount of solder deposited will minimize the occurrence of lead shorts. Since for 0.5mm pitch devices the leads are only 0.25mm wide, the stencil apertures should not be made narrower; openings in stencils  $< 0.25\text{mm}$  wide are difficult to maintain repeatable solder release.
2. The stencil lead land apertures should therefore be shortened in length by 80% and centered on the lead land.
3. The center land pad aperture should be striped with 0.25mm wide openings and spaces to deposit approximately 50% area of solder on the center pad. If too much solder is deposited on the center land pad the part will float and the lead lands will be open.
4. The maximum length and width of the center land pad stencil aperture should be equal to the solder resist opening minus an annular 0.2mm pull back to decrease the incidence of shorting the center land to the lead lands when the part is pushed into the solder paste.

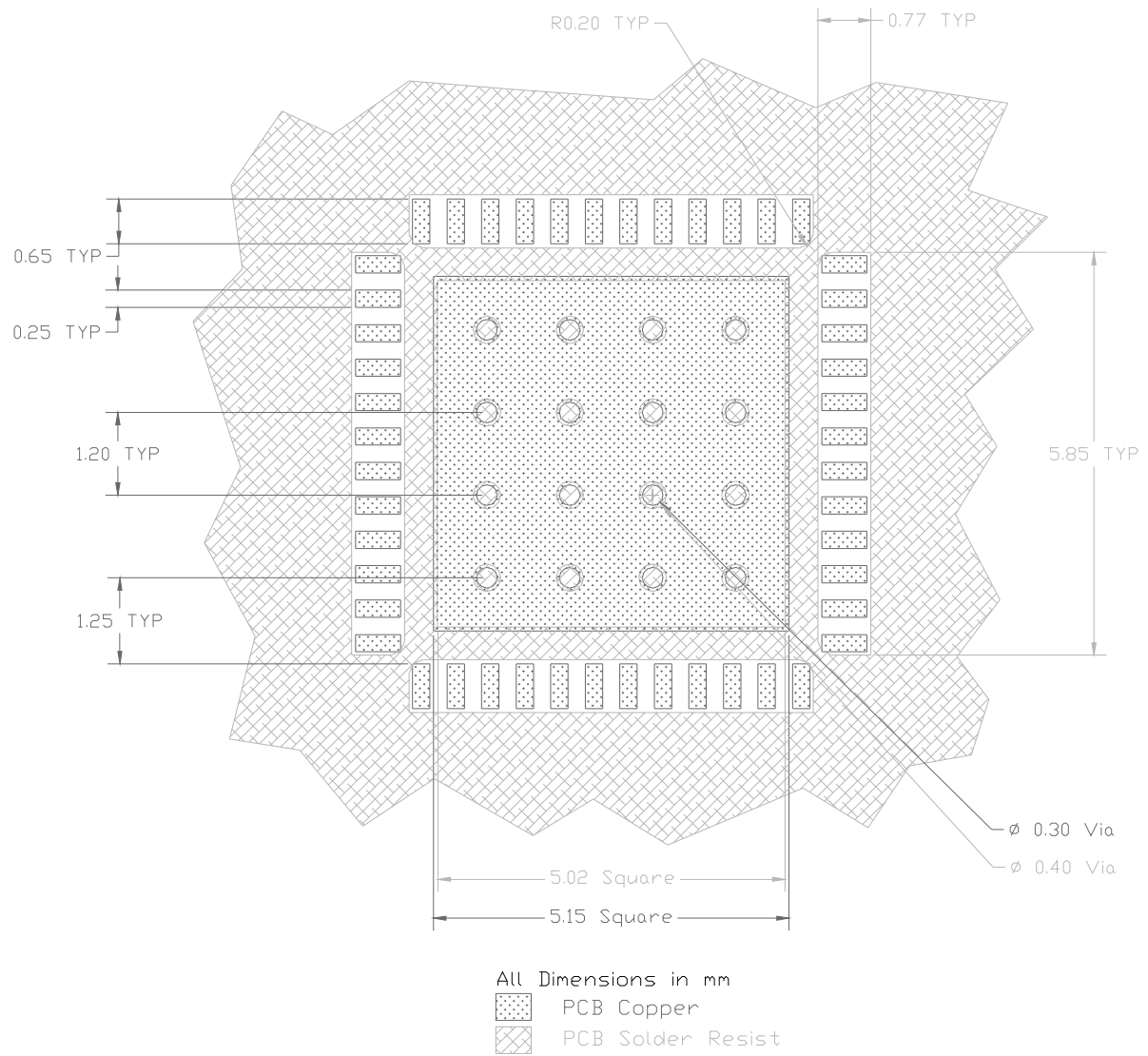

**Figure 14. PCB metal and solder resist.**

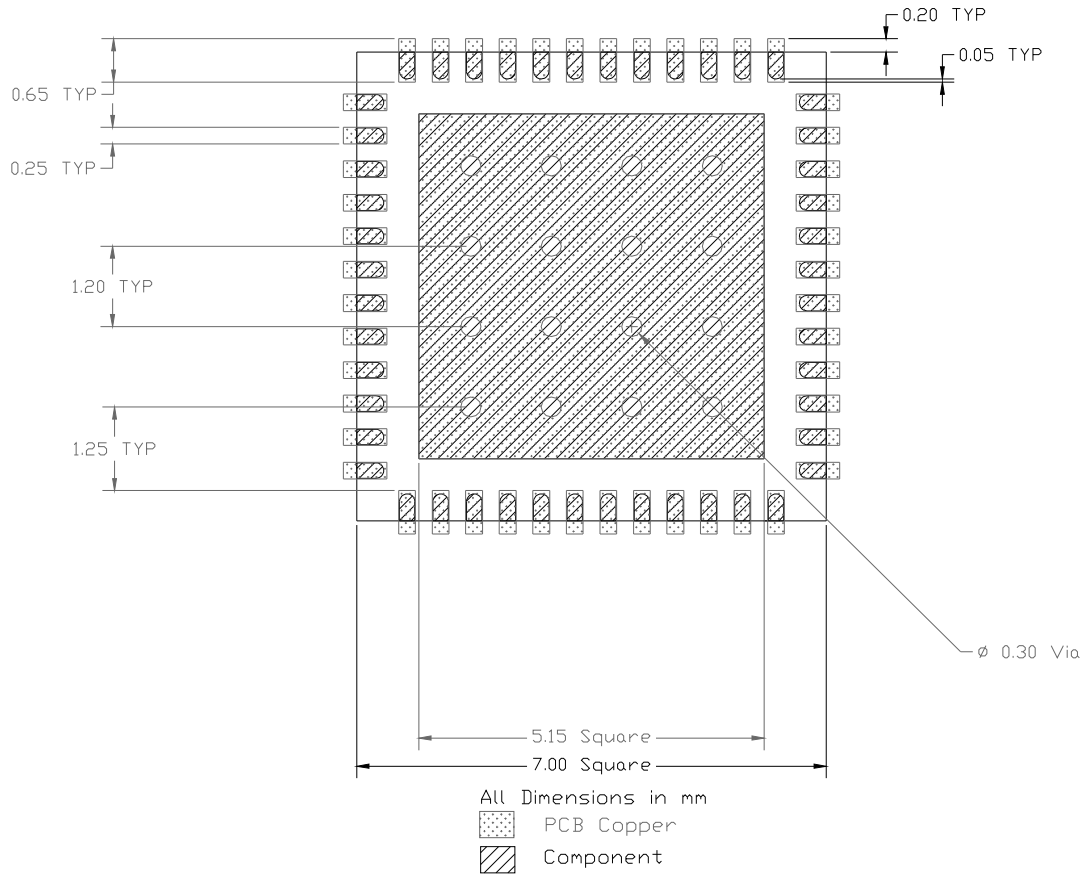

**Figure 15. PCB metal and component placement.**

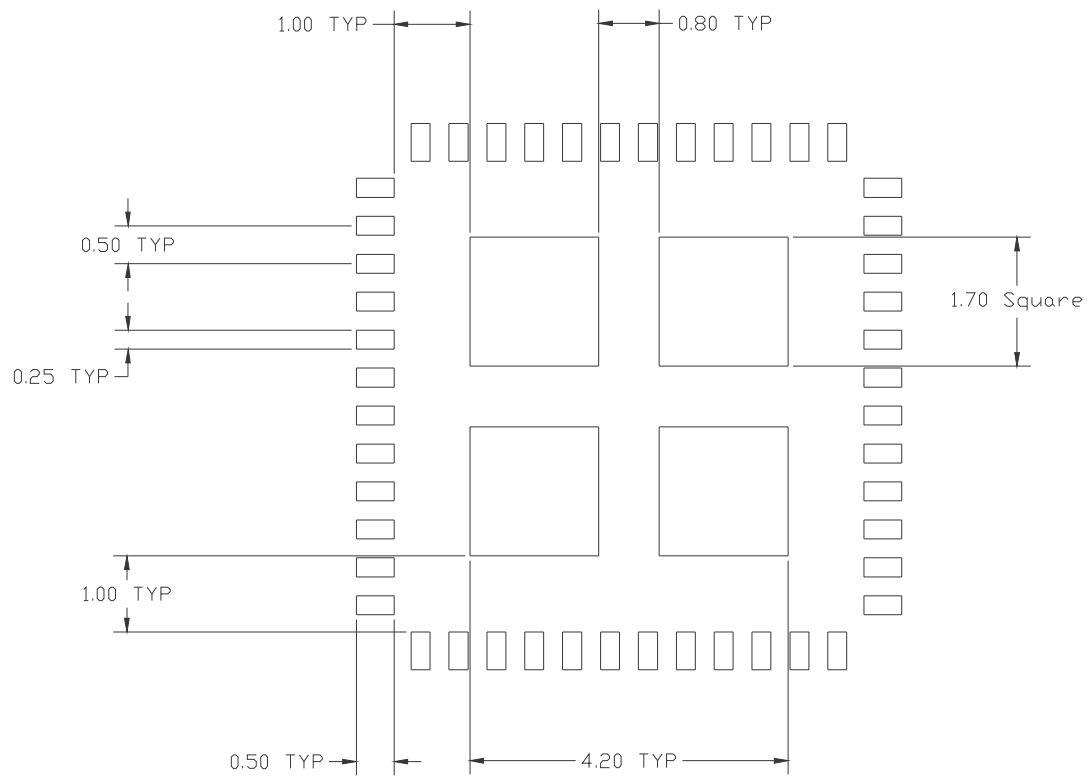

Stencil Aperture  
All Dimensions in mm

**Figure 16. Stencil design.**

**PACKAGE DIMENSIONS**

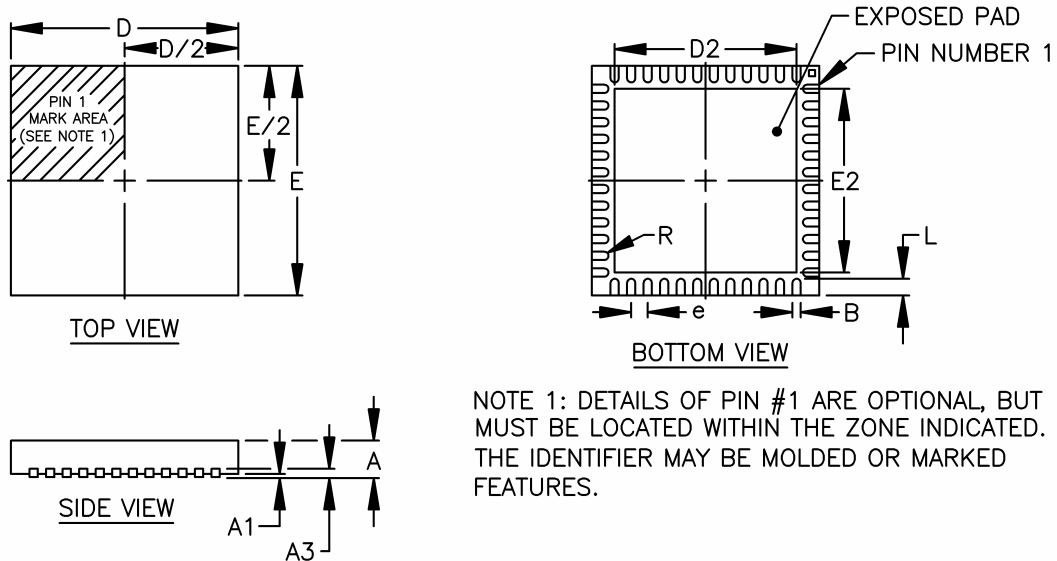

SYMBOL	48-PIN 7X7		
	MIN	NOM	MAX
A	0.80	0.90	1.00
A1	0.00	0.02	0.05
A3	0.20 REF		
B	0.18	0.25	0.30
D	7.00 BSC		
D2	5.50	5.65	5.80
E	7.00 BSC		
E2	5.50	5.65	5.80
e	0.50 BSC		
L	0.35	0.40	0.45
R	0.09	—	—

NOTE: ALL DIMENSIONS ARE IN MILLIMETERS.

Data and specifications subject to change without notice.  
 This product has been designed and qualified for the Consumer market.  
 Qualification Standards can be found on IR's Web site.

This datasheet has been downloaded from:

[www.DatasheetCatalog.com](http://www.DatasheetCatalog.com)

Datasheets for electronic components.



LittleDiode supplies new, hard to find or obsolete electronic components and semiconductors all over the world.

With over two million different components listed you are sure to find the part you need.

Feel free to visit us today at our online store:

[LittleDiode.com](http://LittleDiode.com)

Looking forward to providing you with the best possible service.