

IRIS4007(K)

INTEGRATED SWITCHER

Features

- Primary current mode control, and secondary voltage mode control
- Vcc over-voltage protection (latched)
- Over-current and over-temperature protection
- Quasi resonant, variable frequency operation
- 5 pin TO-220 and TO-262 package
- 0.4Ω Rds(on) max/ 200V MOSFET
- **Fully Characterized Avalanche Energy**

Packages

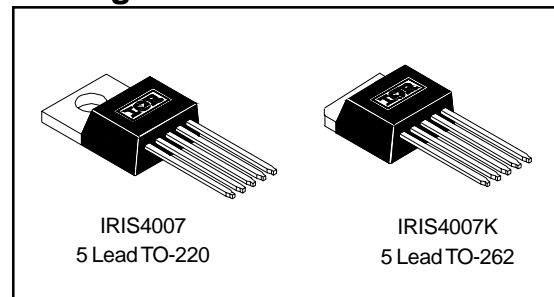

Descriptions

The IRIS4007(K) is a dual mode voltage and current controller combined with a MOSFET in a single Package. The IRIS4007(K) are designed for use in AC/DC and DC/DC switching power supplies upto 100VDC nominal input and is capable of 30W for a nominal 48V input. The device can operate in either a quasi-resonant or Pulse Ratio Control (PRC) mode, and thereby variable frequency operation.

Typical Connection Diagram

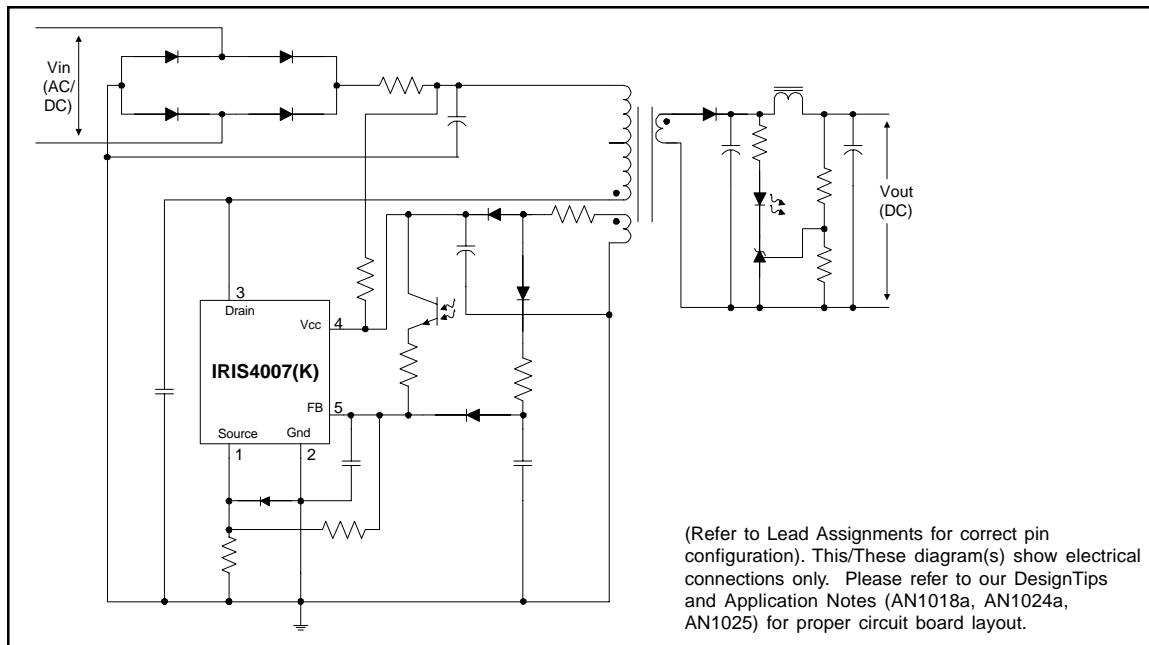

Absolute Maximum Ratings

Absolute maximum ratings indicate sustained limits beyond which damage to the device may occur. All voltage parameters are absolute voltages referenced to terminals stated, all currents are defined positive into any lead. The thermal resistance and power dissipation ratings are measured under board mounted and still air conditions.

Symbol	Definition	Terminals	Max. Ratings	Units	Note
I_{Dpeak}	Peak drain current	3-1	20	A	Single pulse
I_{Dmax}	Maximum switching current	3-1	4.0		$V_{2-3} = 0.78V$ $T_c = 25^\circ C$
E_{AS}	Single pulse avalanche energy	3-1	350	mJ	$V_{dd} = 50V, L = 10mH,$ $T_c = 25^\circ C$
V_{CC}	Power supply voltage	4-3	35	V	
V_{TH}	OCP/FB terminal voltage	5-2	6		
P_{D1}	Power dissipation for MOSFET	3-1	73	W	With infinite heatsink
			1.27		Without heatsink
P_{D2}	Power dissipation for control part (MIC)	4-2	0.8		Specified by $V_{IN} \times I_{IN}$
R_{thJC}	Thermal resistance, junction to case	—	1.7	$^\circ C/W$	
T_J	Junction temperature	—	-40-125	$^\circ C$	
T_S	Storage temperature	—	-40-125		
T_f	Internal frame temperature in operation	—	-20-125		Refer to recommended operating temperature
T_{OP}	Ambient operating temperature	—	-20-125		
T_L	Lead temp. (soldering, 10 seconds)	—	300		

Recommended Operating Conditions

Time for input of quasi resonant signals.

For the Quasi resonant signal inputted to the $V_{DCP/FB}$ terminal at the time of quasi resonant operation, the signal should be wider than $T_{th}(2)$

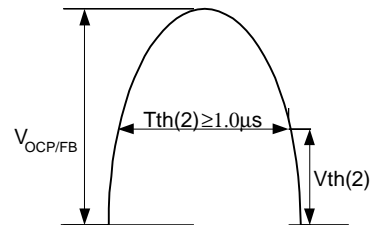

Electrical Characteristics (for Control IC)

$V_{CC} = 18V$, ($T_A = 25^\circ C$) unless otherwise specified.

Symbol	Definition	Min.	Typ.	Max.	Units	Test Conditions
V_{CCUV+}	V_{CC} supply undervoltage positive going threshold	14.4	16	17.6	V	
V_{CCUV-}	V_{CC} supply undervoltage negative going threshold	9	10	11		
I_{QCCUV}	UVLO mode quiescent current	—	—	100	μA	$V_{CC} < V_{CCUV+}$
I_{QCC}	Quiescent operating V_{CC} supply current	—	—	30	mA	
$T_{OFF(MAX)}$	Maximum OFF time	40	—	60	μsec	
$T_{TH(2)}$	Minimum input pulse width for quasi resonant signals	—	—	1.0		
$T_{OFF(MIN)}$	Minimum OFF time	—	—	1.5		
$V_{TH(1)}$	OCP/FB terminal threshold voltage 1	0.68	0.73	0.78	V	
$V_{TH(2)}$	OCP/FB terminal threshold voltage 2	1.3	1.45	1.6		
$I_{OCP/FB}$	OCP/FB terminal sink current	1.1	1.35	1.7	mA	
$V_{CC(OVP)}$	V_{CC} overvoltage protection limit	20.5	22.5	24.5	V	
$I_{CC(LA)}$	Latch circuit holding current	—	—	400	μA	
$V_{CC(LaOFF)}$	Latch circuit reset voltage	6.6	—	8.4	V	
$T_{J(TSD)}$	Thermal shutdown activation temperature	140	—	—	$^\circ C$	

Electrical Characteristics (for MOSFET)

($T_A = 25^\circ C$) unless otherwise specified.

Symbol	Definition	Min.	Typ.	Max.	Units	Test Conditions
V_{DSS}	Drain-to-source breakdown voltage	200	—	—	V	
I_{DSS}	Drain leakage current	—	—	250	μA	$V_{ds}=160V, V_{CC}=0V$ $T_j=125^\circ C$
$R_{DS(ON)}$	On-resistance	—	—	0.4	Ω	$V_{3-1}=10V, I_D=4A$
t_r	Rise time (10% to 90%)	—	—	200	ns	
θ_{J-C}	Thermal resistance	—	—	1.7	$^\circ C/W$	Between junction and case

IRIS4007(K)

Block Diagram

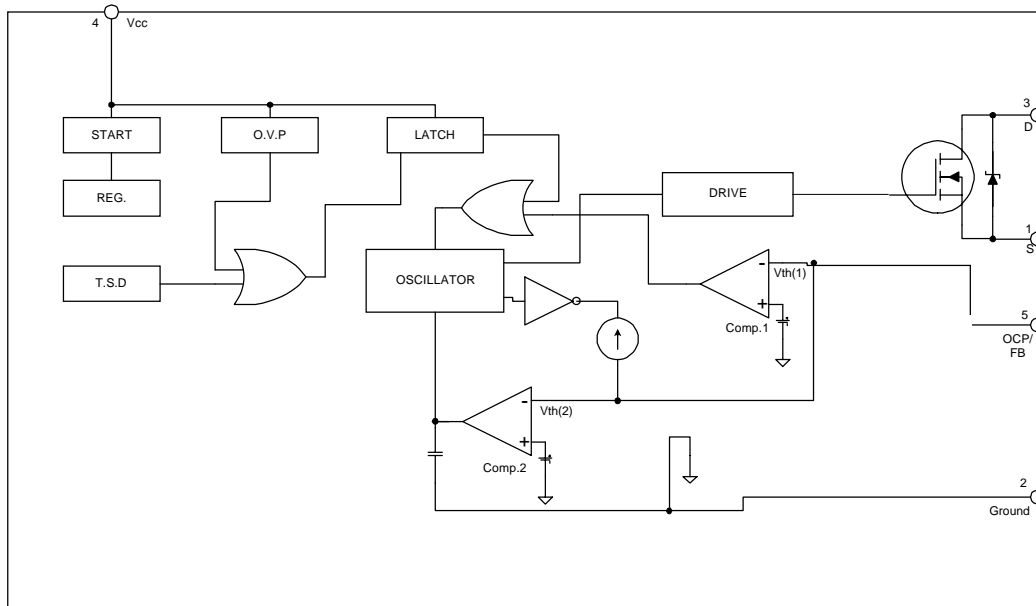

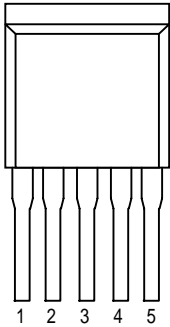
Lead Assignments	Pin #	Symbol	Description
	1	S	MOSFET Source terminal
	2	Ground	Ground terminal
	3	D	MOSFET Drain terminal
	4	Vcc	Control circuit supply voltage
	5	OCP/FB	Overcurrent detection, and Voltage mode control feedback signal

Other Functions

O.V.P. – Overvoltage Protection Circuit
T.S.D. – Thermal Shutdown Circuit

Case outline

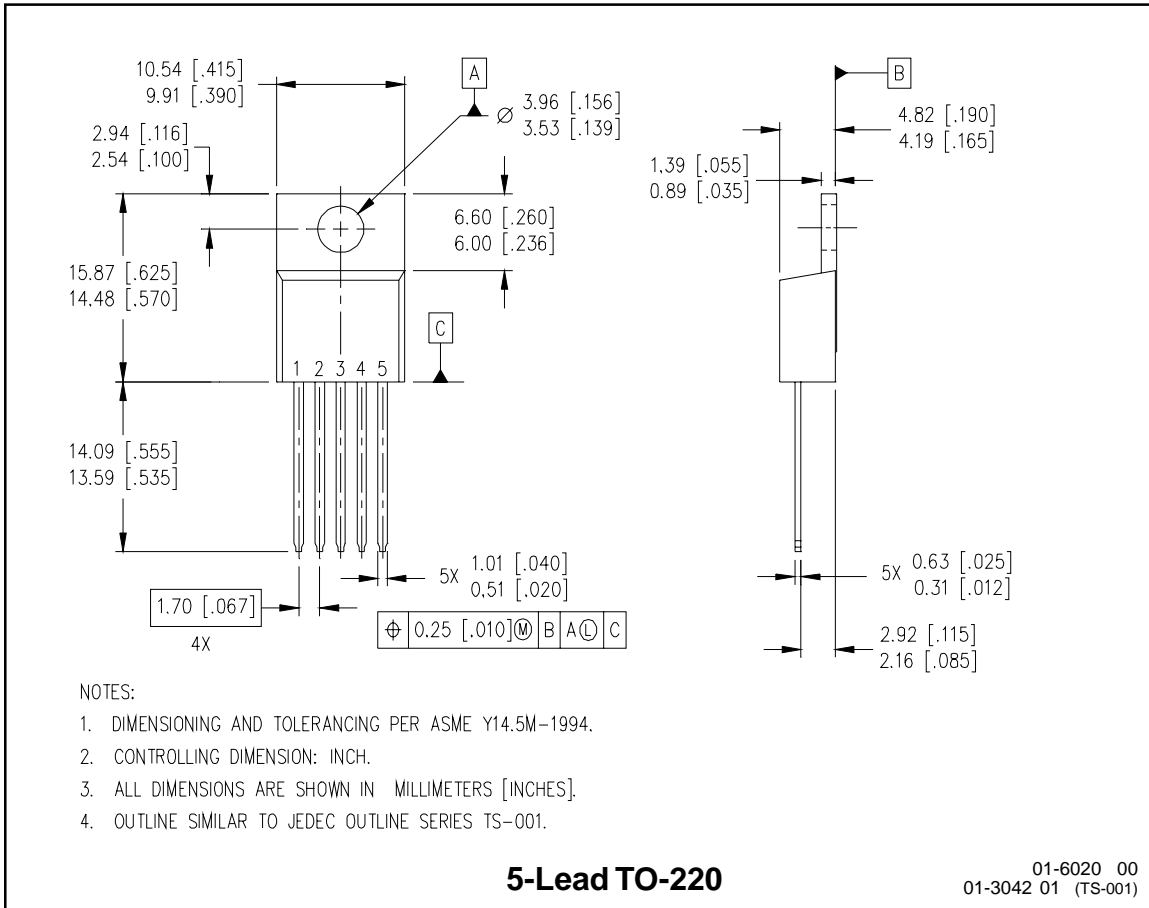

IRIS4007(K)

International
IR Rectifier

Case outline

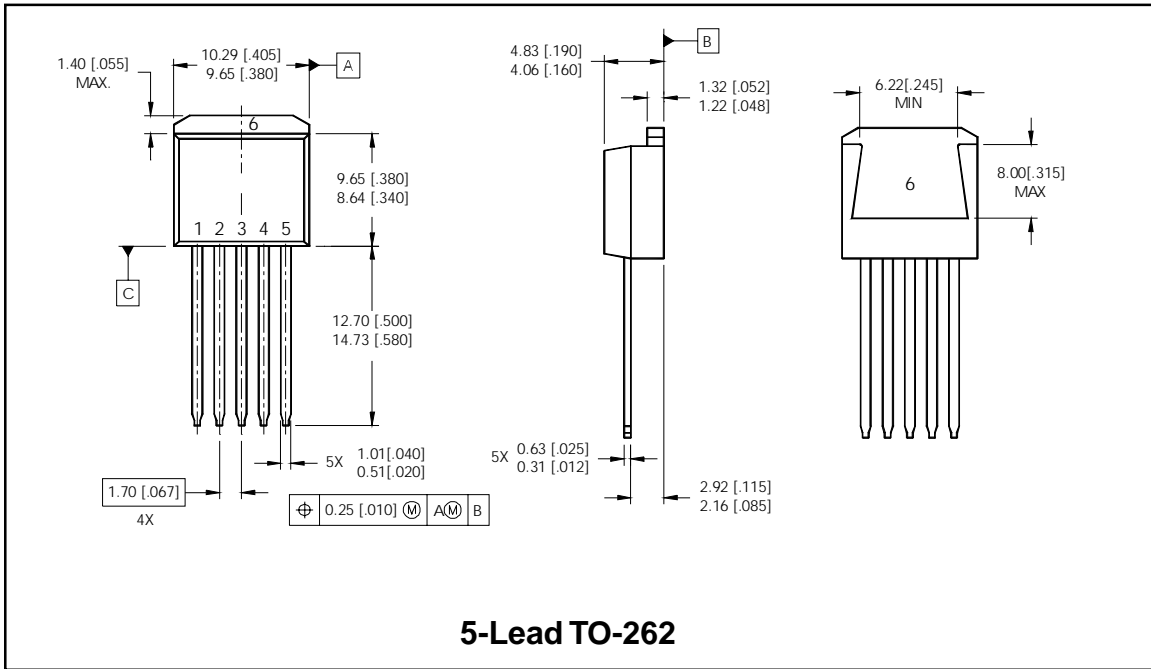

International
IR Rectifier
IR WORLD HEADQUARTERS: 233 Kansas Street, El Segundo, California 90245 Tel: (310) 252-7105
Data and specifications subject to change without notice. 10/17/2001



LittleDiode supplies new, hard to find or obsolete electronic components and semiconductors all over the world.

With over two million different components listed you are sure to find the part you need.

Feel free to visit us today at our online store:

LittleDiode.com

Looking forward to providing you with the best possible service.