

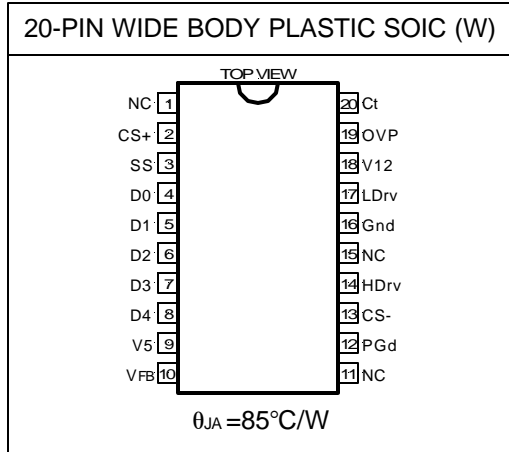

## ABSOLUTE MAXIMUM RATINGS

V5 Supply Voltage .....	7V
V12 Supply Voltage .....	20V
Storage Temperature Range .....	-65°C To 150°C
Operating Junction Temperature Range .....	0°C To 125°C

## PACKAGE INFORMATION



## ELECTRICAL SPECIFICATIONS

Unless otherwise specified, these specifications apply over V12=12V, V5=5V and T<sub>A</sub>=0 to 70°C. Typical values refer to T<sub>A</sub>=25°C. Low duty cycle pulse testing is used which keeps junction and case temperatures equal to the ambient temperature.

PARAMETER	SYM	TEST CONDITION	MIN	TYP	MAX	UNITS
<b>VID Section</b>						
DAC Output Voltage (Note 1)			0.99Vs	Vs	1.01Vs	V
DAC Output Line Regulation					0.1	%
DAC Output Temp Variation					0.5	%
VID Input LO					0.4	V
VID Input HI			2			V
VID Input Internal Pull-Up Resistor to V5				27		KΩ
<b>Power Good Section</b>						
Under-Voltage lower trip point		V <sub>OUT</sub> Ramping Down	0.89Vs	0.90Vs	0.91Vs	V
Under-Voltage upper trip point		V <sub>OUT</sub> Ramping Up		0.92Vs		V
UV Hysterises			0.015Vs	0.02Vs	0.025Vs	V
Over-Voltage upper trip point		V <sub>OUT</sub> Ramping Up	1.09Vs	1.10Vs	1.11Vs	V
Over-Voltage lower trip point		V <sub>OUT</sub> Ramping Down		1.08Vs		V
OV Hysteresis			0.015Vs	0.02Vs	0.025Vs	V
Power Good Output LO		R <sub>L</sub> =3mA			0.4	V
Power Good Output HI		R <sub>L</sub> =5K Pull-Up to 5V	4.8			V
<b>Soft-Start Section</b>						
Soft-Start Current		CS+=0V, CS-=5V		10		μA

PARAMETER	SYM	TEST CONDITION	MIN	TYP	MAX	UNITS
<b>UVLO Section</b>						
UVLO Threshold-12V		Supply Ramping Up	9.2	10	10.8	V
UVLO Hysteresis-12V			0.3	0.4	0.5	V
UVLO Threshold-5V		Supply Ramping Up	4.1	4.3	4.5	V
UVLO Hysteresis-5V			0.2	0.3	0.4	V
<b>Error Comparator Section</b>						
Input Bias Current					2	μA
Input Offset Voltage			-2		+2	mV
Delay to Output		V <sub>DIFF</sub> =10mV			100	ns
<b>Current Limit Section</b>						
CS Threshold Set Current			160	200	240	μA
CS Comp Offset Voltage			-5		+5	mV
Hiccup Duty Cycle		C <sub>SS</sub> =0.1μF			2	%
<b>Supply Current</b>						
Operating Supply Current		C <sub>L</sub> =3000pF: V5 V12		20 14		mA
<b>Output Drivers Section</b>						
Rise Time		C <sub>L</sub> =3000pF		70	100	ns
Fall Time		C <sub>L</sub> =3000pF		70	130	ns
Dead Band Time		C <sub>L</sub> =3000pF	100	200	300	ns
<b>Oscillator Section</b>						
Osc Frequency		C <sub>t</sub> =150pF	190	220	250	KHz
Osc Valley					0.2	V
Osc Peak				V5		V
<b>Over-Voltage Section</b>						
OVP Drive Current						mA

**Note 1:** V<sub>s</sub> refers to the set point voltage given in Table 1.

D4	D3	D2	D1	D0	V <sub>s</sub>
0	1	1	1	1	1.30
0	1	1	1	0	1.35
0	1	1	0	1	1.40
0	1	1	0	0	1.45
0	1	0	1	1	1.50
0	1	0	1	0	1.55
0	1	0	0	1	1.60
0	1	0	0	0	1.65
0	0	1	1	1	1.70
0	0	1	1	0	1.75
0	0	1	0	1	1.80
0	0	1	0	0	1.85
0	0	0	1	1	1.90
0	0	0	1	0	1.95
0	0	0	0	1	2.00
0	0	0	0	0	2.05
D4	D3	D2	D1	D0	V <sub>s</sub>
1	1	1	1	1	2.0
1	1	1	1	0	2.1
1	1	1	0	1	2.2
1	1	1	0	0	2.3
1	1	0	1	1	2.4
1	1	0	1	0	2.5
1	1	0	0	1	2.6
1	1	0	0	0	2.7
1	0	1	1	1	2.8
1	0	1	1	0	2.9
1	0	1	0	1	3.0
1	0	1	0	0	3.1
1	0	0	1	1	3.2
1	0	0	1	0	3.3
1	0	0	0	1	3.4
1	0	0	0	0	3.5

Table 1 - Set point voltage vs. VID codes.

**PIN DESCRIPTIONS**

PIN#	PIN SYMBOL	PIN DESCRIPTION
1	NC	No connection.
2	CS+	This pin is connected to the Drain of the power MOSFET of the Core supply and it provides the positive sensing for the internal current sensing circuitry. An external resistor programs the CS threshold depending on the $R_{DS}$ of the power MOSFET. An external capacitor is placed in parallel with the programming resistor to provide high frequency noise filtering.
3	SS	This pin provides the soft-start for the switching regulator. An internal current source charges an external capacitor that is connected from this pin to the ground which ramps up the outputs of the switching regulator, preventing the outputs from overshooting as well as limiting the input current. The second function of the Soft-Start cap is to provide long off time for the synchronous MOSFET or the Catch diode (HICCUP) during current limiting.
4	D0	LSB input to the DAC that programs the output voltage. This pin can be pulled up externally by a 10K resistor to either 3.3V or 5V supply.
5	D1	Input to the DAC that programs the output voltage. This pin can be pulled-up externally by a 10K $\Omega$ resistor to either 3.3V or 5V supply.
6	D2	Input to the DAC that programs the output voltage. This pin can be pulled-up externally by a 10K resistor to either 3.3V or 5V supply.
7	D3	MSB input to the DAC that programs the output voltage. This pin can be pulled-up externally by a 10K resistor to either 3.3V or 5V supply.
8	D4	This pin selects a range of output voltages for the DAC.
9	V5	5V supply voltage.
10	V <sub>FB</sub>	This pin is connected directly to the output of the Core supply to provide feedback to the Error comparator.
11	NC	No connection.
12	PGd	This pin is an open collector output that switches LO when the output of the converter is not within $\pm 10\%$ (typ) of the nominal output voltage. When PGd pin switches LO the saturation voltage is less than 0.4V at 3mA.
13	CS-	This pin is connected to the Source of the power MOSFET for the Core supply and it provides the negative sensing for the internal current sensing circuitry.
14	HDrv	Output driver for the high side power MOSFET.
15	NC	No connection.
16	Gnd	This pin serves as the ground pin and must be connected directly to the ground plane. A high frequency capacitor (0.1 to 1 $\mu$ F) must be connected from V5 and V12 pins to this pin for noise free operation.
17	LDrv	Output driver for the synchronous power MOSFET.
18	V12	This pin is connected to the 12 V supply and serves as the power Vcc pin for the output drivers. A high frequency capacitor (0.1 to 1 $\mu$ F) must be connected directly from this pin to ground pin in order to supply the peak current to the power MOSFET during the transitions.
19	OVP	Over-voltage comparator output.
20	Ct	This pin programs the oscillator frequency in the range of 50KHz to 500KHz with an external capacitor connected from this pin to the ground.

**BLOCK DIAGRAM**

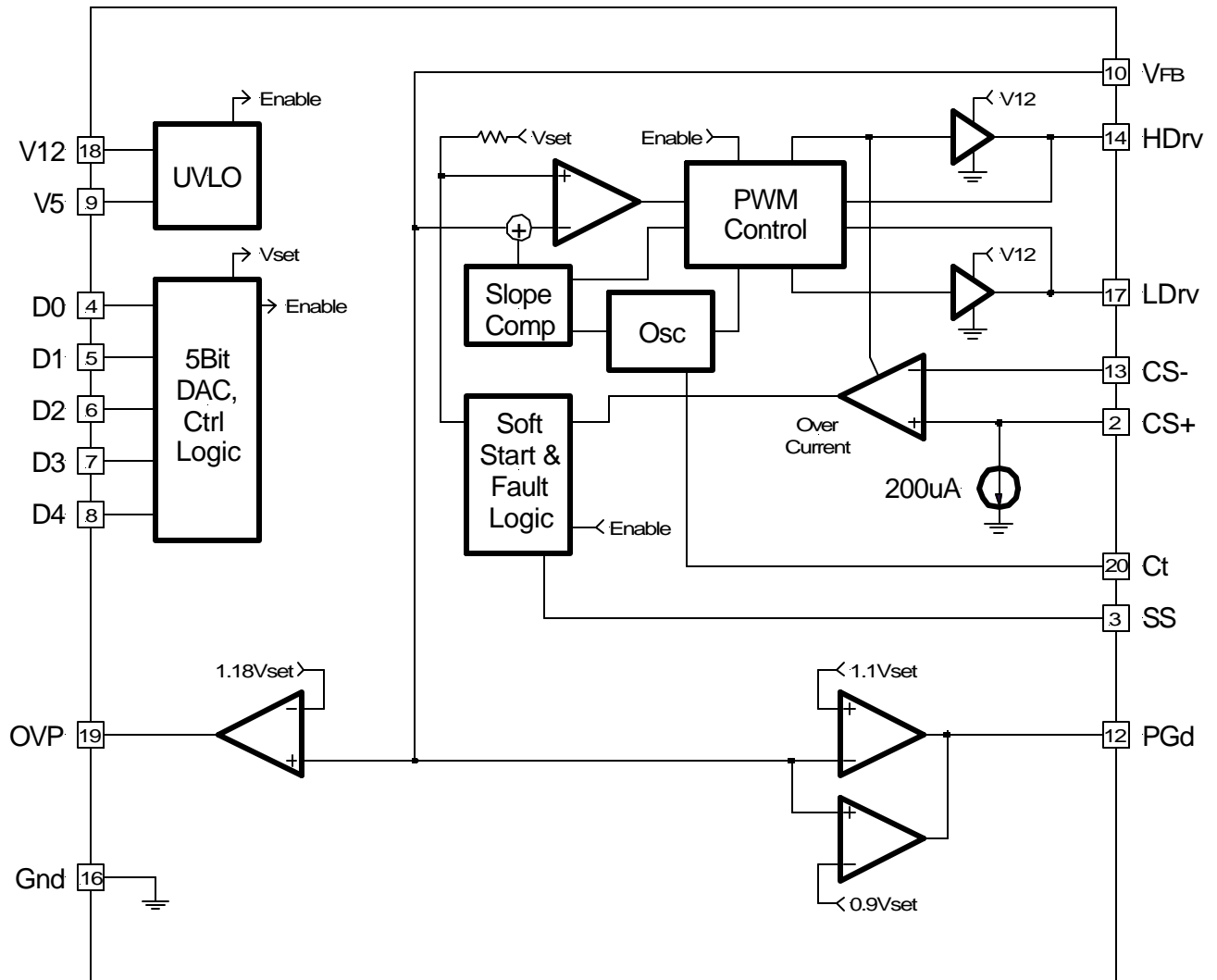

Figure 2 - Simplified block diagram of the IRU3011.

## TYPICAL APPLICATION

### Synchronous Operation

(Dual Layout with HIP6004B)

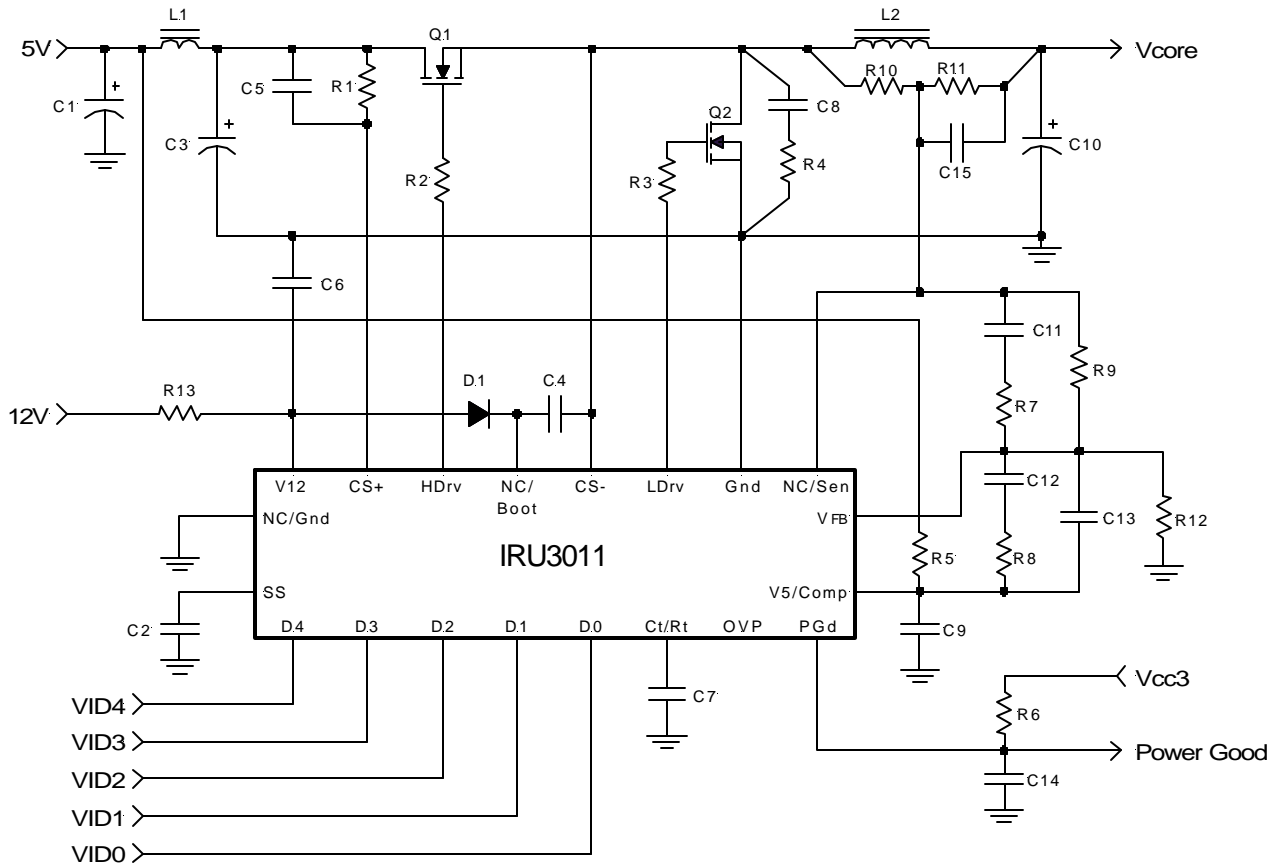

Figure 3 - Typical application of IRU3011 in an on board DC-DC converter providing the Core supply for microprocessor.

Part #	R5	R7	R8	R9	C4	C7	C9	C11	C12	C13	D1
HIP6004B	O	V	V	V	V	O	O	V	V	V	V
IRU3011	S	O	O	V	O	V	V	O	O	O	O

S - Short                      O - Open                      V - See IR or Harris parts list for the value

Table 2 - Components that need to be modified to make the dual layout work for IRU3011 and HIP6004B.

**IRU3011 and HIP6004B Dual Layout Parts List**

Ref Desig	Description	Qty	Part #	Manuf
Q1	MOSFET	1	IRL3103s, TO-263 package	IR
Q2	MOSFET	1	IRL3103D1S, TO-263 package	IR
L1	Inductor	1	L=1 $\mu$ H, 5052 core with 4 turns of 1.0mm wire	Micro Metal
L2	Inductor	1	L=2.7 $\mu$ H, 5052B core with 7 turns of 1.2mm wire	Micro Metal
C1	Capacitor, Electrolytic	1	10MV470GX, 470 $\mu$ F, 10V	Sanyo
C2, 9	Capacitor, Ceramic	2	1 $\mu$ F, 0603	
C3	Capacitor, Electrolytic	2	10MV1200GX, 1200 $\mu$ F, 10V	Sanyo
C5	Capacitor, Ceramic	1	220pF, 0603	
C6	Capacitor, Ceramic	1	1 $\mu$ F, 0805	
C7	Capacitor, Ceramic	1	150pF, 0603	
C8	Capacitor, Ceramic	1	1000pF, 0603	
C10	Capacitor, Electrolytic	6	6MV1500GX, 1500 $\mu$ F, 6.3V	Sanyo
C14	Capacitor, Ceramic	1	0.1 $\mu$ F, 0603	
C15	Capacitor, Ceramic	1	4.7 $\mu$ F, 1206	
R1	Resistor	1	3.3K $\Omega$ , 5%, 0603	
R2, 3, 4	Resistor	3	4.7 $\Omega$ , 5%, 1206	
R5	Resistor	1	0 $\Omega$ , 0603	
R6	Resistor	1	10K $\Omega$ , 5%, 0603	
R9	Resistor	1	100 $\Omega$ , 1%, 0603	
R10	Resistor	1	220 $\Omega$ , 1%, 0603	
R11	Resistor	1	330 $\Omega$ , 1%, 0603	
R12	Resistor	1	22K $\Omega$ , 1%, 0603	
R13	Resistor	1	10 $\Omega$ , 5%, 0603	

**Note 1:** R10, R11, C15, R9, and R12 set the Vcore 2% higher for level shift to reduce CPU transient voltage.

## APPLICATION INFORMATION

An example of how to calculate the components for the application circuit is given below.

Assuming, two sets of output conditions that this regulator must meet,

- a)  $V_o=2.8V$ ,  $I_o=14.2A$ ,  $\Delta V_o=185mV$ ,  $\Delta I_o=14.2A$
- b)  $V_o=2V$ ,  $I_o=14.2A$ ,  $\Delta V_o=140mV$ ,  $\Delta I_o=14.2A$

the regulator design will be done such that it meets the worst case requirement of each condition.

### Output Capacitor Selection

The first step is to select the output capacitor. This is done primarily by selecting the maximum ESR value that meets the transient voltage budget of the total  $\Delta V_o$  specification. Assuming that the regulators DC initial accuracy plus the output ripple is 2% of the output voltage, then the maximum ESR of the output capacitor is calculated as:

$$ESR \leq \frac{100}{14.2} = 7m\Omega$$

The Sanyo MVGX series is a good choice to achieve both the price and performance goals. The 6MV1500GX, 1500 $\mu$ F, 6.3V has an ESR of less than 36m $\Omega$  typical. Selecting 6 of these capacitors in parallel has an ESR of  $\approx 6m\Omega$  which achieves our low ESR goal.

Other type of electrolytic capacitors from other manufacturers to consider are the Panasonic FA series or the Nichicon PL series.

### Reducing the Output Capacitors Using Voltage Level Shifting Technique

The trace resistance or an external resistor from the output of the switching regulator to the Slot 1 can be used to the circuit advantage and possibly reduce the number of output capacitors, by level shifting the DC regulation point when transitioning from light load to full load and vice versa. To accomplish this, the output of the regulator is typically set about half the DC drop that results from light load to full load. For example, if the total resistance from the output capacitors to the Slot 1 and back to the Gnd pin of the device is 5m $\Omega$  and if the total  $\Delta I$ , the change from light load to full load is 14A, then the output voltage measured at the top of the resistor divider which is also connected to the output capacitors in this case, must be set at half of the 70mV or 35mV higher than the DAC voltage setting.

This intentional voltage level shifting during the load transient eases the requirement for the output capacitor ESR at the cost of load regulation. One can show that the new ESR requirement eases up by half the total trace resistance. For example, if the ESR requirement of the output capacitors without voltage level shifting must be 7m $\Omega$  then after level shifting the new ESR will only need to be 8.5m $\Omega$  if the trace resistance is 5m $\Omega$  ( $7 + 5/2=9.5$ ). However, one must be careful that the combined "voltage level shifting" and the transient response is still within the maximum tolerance of the Intel specification. To insure this, the maximum trace resistance must be less than:

$$R_s \leq 2 \times (V_{spec} - 0.02 \times V_o - \Delta V_o) / \Delta I$$

Where :

$R_s$  = Total maximum trace resistance allowed

$V_{spec}$  = Intel total voltage spec

$V_o$  = Output voltage

$\Delta V_o$  = Output ripple voltage

$\Delta I$  = load current step

For example, assuming:

$V_{spec} = \pm 140mV = \pm 0.1V$  for 2V output

$V_o = 2V$

$\Delta V_o = \text{assume } 10mV = 0.01V$

$\Delta I = 14.2A$

Then the  $R_s$  is calculated to be:

$$R_s \leq 2 \times (0.140 - 0.02 \times 2 - 0.01) / 14.2 = 12.6m\Omega$$

However, if a resistor of this value is used, the maximum power dissipated in the trace (or if an external resistor is being used) must also be considered. For example if  $R_s=12.6m\Omega$ , the power dissipated is:

$$I_o^2 \times R_s = 14.2^2 \times 12.6 = 2.54W$$

This is a lot of power to be dissipated in a system. So, if the  $R_s=5m\Omega$ , then the power dissipated is about 1W which is much more acceptable. If level shifting is not implemented, then the maximum output capacitor ESR was shown previously to be 7m $\Omega$  which translated to  $\approx 6$  of the 1500 $\mu$ F, 6MV1500GX type Sanyo capacitors. With  $R_s=5m\Omega$ , the maximum ESR becomes 9.5m $\Omega$  which is equivalent to  $\approx 4$  caps. Another important consideration is that if a trace is being used to implement the resistor, the power dissipated by the trace increases the case temperature of the output capacitors which could seriously effect the life time of the output capacitors.

**Output Inductor Selection**

The output inductance must be selected such that under low line and the maximum output voltage condition, the inductor current slope times the output capacitor ESR is ramping up faster than the capacitor voltage is drooping during a load current step. However, if the inductor is too small, the output ripple current and ripple voltage become too large. One solution to bring the ripple current down is to increase the switching frequency, however, that will be at the cost of reduced efficiency and higher system cost. The following set of formulas are derived to achieve the optimum performance without many design iterations.

The maximum output inductance is calculated using the following equation:

$$L = ESR \times C \times (V_{IN(MIN)} - V_{O(MAX)}) / (2 \times \Delta I)$$

Where:

$V_{IN(MIN)}$  = Minimum input voltage  
 For  $V_o=2.8V$  and  $\Delta I=14.2A$

$$L = 0.006 \times 9000 \times (4.75 - 2.8) / (2 \times 14.2) = 3.7\mu H$$

Assuming that the programmed switching frequency is set at 200KHz, an inductor is designed using the Micrometals' powder iron core material. The summary of the design is outlined below:

The selected core material is Powder Iron, the selected core is T50-52D from Micro Metal wound with 8 turns of #16 AWG wire, resulting in  $3\mu H$  inductance with  $\approx 3m\Omega$  of DC resistance.

Assuming  $L=3\mu H$  and  $F_{sw}=200KHz$ (switching frequency), the inductor ripple current and the output ripple voltage is calculated using the following set of equations:

$T \equiv$  Switching Period  
 $D \equiv$  Duty Cycle  
 $V_{sw} \equiv$  High-side MOSFET ON Voltage  
 $R_{DS} \equiv$  MOSFET On-Resistance  
 $V_{sync} \equiv$  Synchronous MOSFET ON Voltage  
 $\Delta I_r \equiv$  Inductor Ripple Current  
 $\Delta V_o \equiv$  Output Ripple Voltage  
 $T = 1/F_{sw}$   
 $V_{sw} = V_{sync} = I_o \times R_{DS}$   
 $D \approx (V_o + V_{sync}) / (V_{IN} - V_{sw} + V_{sync})$   
 $T_{ON} = D \times T$   
 $T_{OFF} = T - T_{ON}$   
 $\Delta I_r = (V_o + V_{sync}) \times T_{OFF} / L$   
 $\Delta V_o = \Delta I_r \times ESR$

In our example for  $V_o=2.8V$  and 14.2A load, assuming IRL3103 MOSFET for both switches with maximum on resistance of  $19m\Omega$ , we have:

$$\begin{aligned}
 T &= 1 / 200000 = 5\mu s \\
 V_{sw} &= V_{sync} = 14.2 \times 0.019 = 0.27V \\
 D &\equiv (2.8 + 0.27) / (5 - 0.27 + 0.27) = 0.61 \\
 T_{ON} &= 0.61 \times 5 = 3.1\mu s \\
 T_{OFF} &= 5 - 3.1 = 1.9\mu s \\
 \Delta I_r &= (2.8 + 0.27) \times 1.9 / 3 = 1.94A \\
 \Delta V_o &= 1.94 \times 0.006 = 0.011V = 11mV
 \end{aligned}$$

**Power Component Selection**

Assuming IRL3103 MOSFETs as power components, we will calculate the maximum power dissipation as follows:

For high-side switch the maximum power dissipation happens at maximum  $V_o$  and maximum duty cycle.

$$\begin{aligned}
 D_{MAX} &\equiv (2.8 + 0.27) / (4.75 - 0.27 + 0.27) = 0.65 \\
 P_{DH} &= D_{MAX} \times I_o^2 \times R_{DS(MAX)} \\
 P_{DH} &= 0.65 \times 14.2^2 \times 0.029 = 3.8W
 \end{aligned}$$

$R_{DS(MAX)}$  = Maximum  $R_{DS(ON)}$  of the MOSFET at 125°C  
 For synch MOSFET, maximum power dissipation happens at minimum  $V_o$  and minimum duty cycle.

$$\begin{aligned}
 D_{MIN} &\equiv (2 + 0.27) / (5.25 - 0.27 + 0.27) = 0.43 \\
 P_{DS} &= (1 - D_{MIN}) \times I_o^2 \times R_{DS(MAX)} \\
 P_{DS} &= (1 - 0.43) \times 14.2^2 \times 0.029 = 3.33W
 \end{aligned}$$

**Heat Sink Selection**

Selection of the heat sink is based on the maximum allowable junction temperature of the MOSFETS. Since we previously selected the maximum  $R_{DS(ON)}$  at 125°C, then we must keep the junction below this temperature. Selecting TO-220 package gives  $\theta_{JC}=1.8^\circ C/W$  (From the vendors' data sheet) and assuming that the selected heat sink is black anodized, the heat-sink-to-case thermal resistance is  $\theta_{CS}=0.05^\circ C/W$ , the maximum heat sink temperature is then calculated as:

$$\begin{aligned}
 T_s &= T_J - P_D \times (\theta_{JC} + \theta_{CS}) \\
 T_s &= 125 - 3.82 \times (1.8 + 0.05) = 118^\circ C
 \end{aligned}$$

With the maximum heat sink temperature calculated in the previous step, the heat-sink-to-air thermal resistance ( $\theta_{SA}$ ) is calculated as follows:

Assuming  $T_A = 35^\circ C$ :

$$\begin{aligned}
 \Delta T &= T_s - T_A = 118 - 35 = 83^\circ C \\
 &\text{Temperature Rise Above Ambient} \\
 \theta_{SA} &= \Delta T / P_D = 83 / 3.82 = 22^\circ C/W
 \end{aligned}$$

Next, a heat sink with lower  $\theta_{SA}$  than the one calculated in the previous step must be selected. One way to do this is to simply look at the graphs of the “Heat Sink Temp Rise Above the Ambient” vs. the “Power Dissipation” given in the heat sink manufacturers’ catalog and select a heat sink that results in lower temperature rise than the one calculated in previous step. The following AAVID and Thermalloy heat sinks, meet this criteria.

<u>Co.</u>	<u>Part #</u>
Thermalloy.....	6078B
AAVID.....	577002

Following the same procedure for the Schottky diode results in a heatsink with  $\theta_{SA}=25^{\circ}\text{C/W}$ . Although it is possible to select a slightly smaller heatsink, for simplicity the same heatsink as the one for the high side MOSFET is also selected for the synchronous MOSFET.

### Switcher Current Limit Protection

The PWM controller uses the MOSFET  $R_{DS(ON)}$  as the sensing resistor to sense the MOSFET current and compares to a programmed voltage which is set externally via a resistor ( $R_{CS}$ ) placed between the drain of the MOSFET and the “CS+” terminal of the IC as shown in the application circuit. For example, if the desired current limit point is set to be 22A and from our previous selection, the maximum MOSFET  $R_{DS(ON)}=19\text{m}\Omega$ , then the current sense resistor,  $R_{CS}$  is calculated as:

$$V_{CS} = I_{CL} \times R_{DS} = 22 \times 0.019 = 0.418\text{V}$$

$$R_{CS} = V_{CS} / I_B = (0.418\text{V}) / (200\mu\text{A}) = 2.1\text{K}\Omega$$

Where:  
 $I_B = 200\mu\text{A}$  is the internal current setting of the IRU3011

### Switcher Timing Capacitor Selection

The switching frequency can be programmed using an external timing capacitor. The value of  $C_t$  can be approximated using the equation below:

$$F_{SW} \approx \frac{3.5 \times 10^{-5}}{C_t}$$

Where:  
 $C_t$  = Timing Capacitor  
 $F_{SW}$  = Switching Frequency

If,  $F_{SW} = 200\text{KHz}$ :

$$C_t \approx \frac{3.5 \times 10^{-5}}{200 \times 10^3} = 175\text{pF}$$

### Switcher Output Voltage Adjust

As it was discussed earlier, the trace resistance from the output of the switching regulator to the Slot 1 can be used to the circuit advantage and possibly reduce the number of output capacitors, by level shifting the DC regulation point when transitioning from light load to full load and vice versa. To account for the DC drop, the output of the regulator is typically set about half the DC drop that results from light load to full load. For example, if the total resistance from the output capacitors to the Slot 1 and back to the Gnd pin of the device is  $5\text{m}\Omega$  and if the total  $\Delta I$ , the change from light load to full load is 14A, then the output voltage measured at the top of the resistor divider which is also connected to the output capacitors in this case, must be set at half of the 70mV or 35mV higher than the DAC voltage setting. To do this, the top resistor of the resistor divider,  $R_{TOP}$  is set at  $100\Omega$ , and the bottom resistor,  $R_B$  is calculated. For example, if DAC voltage setting is for 2.8V and the desired output under light load is 2.835V, then  $R_B$  is calculated using the following formula:

$$R_B = 100 \times [V_{DAC} / (V_O - 1.004 \times V_{DAC})] \quad [\Omega]$$

$$R_B = 100 \times [2.8 / (2.835 - 1.004 \times 2.800)] = 11.76\text{K}\Omega$$

Select 11.8K $\Omega$ , 1%

**Note:** The value of the top resistor must not exceed  $100\Omega$ . The bottom resistor can then be adjusted to raise the output voltage.

### Soft-Start Capacitor Selection

The soft-start capacitor must be selected such that during the start up when the output capacitors are charging up, the peak inductor current does not reach the current limit threshold. A minimum of  $1\mu\text{F}$  capacitor insures this for most applications. An internal  $10\mu\text{A}$  current source charges the soft-start capacitor which slowly ramps up the inverting input of the PWM comparator  $V_{FB3}$ . This insures the output voltage to ramp at the same rate as the soft-start cap thereby limiting the input current. For example, with  $1\mu\text{F}$  and the  $10\mu\text{A}$  internal current source the ramp up rate is  $(\Delta V / \Delta t) = I / C = 1\text{V} / 100\text{ms}$ . Assuming that the output capacitance is  $9000\mu\text{F}$ , the maximum start up current will be:

$$I = 9000\mu\text{F} \times (1\text{V} / 100\text{ms}) = 0.09\text{A}$$

### Input Filter

It is recommended to place an inductor between the system 5V supply and the input capacitors of the switching regulator to isolate the 5V supply from the switching noise that occurs during the turn on and off of the switching components. Typically an inductor in the range of 1 to  $3\mu\text{H}$  will be sufficient in this type of application.

**Switcher External Shutdown**

The best way to shutdown the part is to pull down on the soft-start pin using an external small signal transistor such as 2N3904 or 2N7002 small signal MOSFET. This allows slow ramp up of the output, the same as the power up.

**Layout Considerations**

Switching regulators require careful attention to the layout of the components, specifically power components since they switch large currents. These switching components can create large amount of voltage spikes and high frequency harmonics if some of the critical components are far away from each other and are connected with inductive traces. The following is a guideline of how to place the critical components and the connections between them in order to minimize the above issues.

Start the layout by first placing the power components:

- 1) Place the input capacitors C3 and the high side MOSFET, Q1 as close to each other as possible
- 2) Place the synchronous MOSFETs, Q2 and the Q1 as close to each other as possible with the intention that the connection from the source of Q1 and the drain of the Q2 has the shortest length.
- 3) Place the snubber R4 & C7 between Q1 & Q2.
- 4) Place the output inductor, L2 and the output capacitors, C10 between the MOSFET and the load with output capacitors distributed along the slot 1 and close to it.
- 5) Place the bypass capacitors, C6 and C9 right next to 12V and 5V pins. C6 next to the 12V, pin 18 and C9 next to the 5V, pin 9.
- 6) Place the IC such that the PWM output drives, pins 14 and 17 are relatively short distance from gates of Q1 and Q2.

- 7) If the output voltage is to be adjusted, place resistor dividers close to the feedback pin.

**Note:** Although, the device does not require resistor dividers and the feedback pin can be directly connected to the output, they can be used to set the outputs slightly higher to account for any output drop at the load due to the trace resistance. See the application note.

- 8) Place timing capacitor C7 close to pin 20 and soft-start capacitor C2 close to pin 3.

Component connections:

**Note:** It is extremely important that no data bus should be passing through the switching regulator section specifically close to the fast transition nodes such as PWM drives or the inductor voltage.

Using 4 layer board, dedicate on layer to Gnd, another layer as the power layer for the 5V, 3.3V and Vcore.

Connect all grounds to the ground plane using direct vias to the ground plane.

Use large low inductance/low impedance plane to connect the following connections either using component side or the solder side.

- a) C3 to Q1 Drain
- b) Q1 Source to Q2 Drain
- c) Q2 drain to L2
- d) L2 to the output capacitors, C10
- e) C10 to the slot 1
- f) Input filter L1 to the C3

Connect the rest of the components using the shortest connection possible.

**(W) SOIC Package**  
**20-Pin Surface Mount, Wide Body**

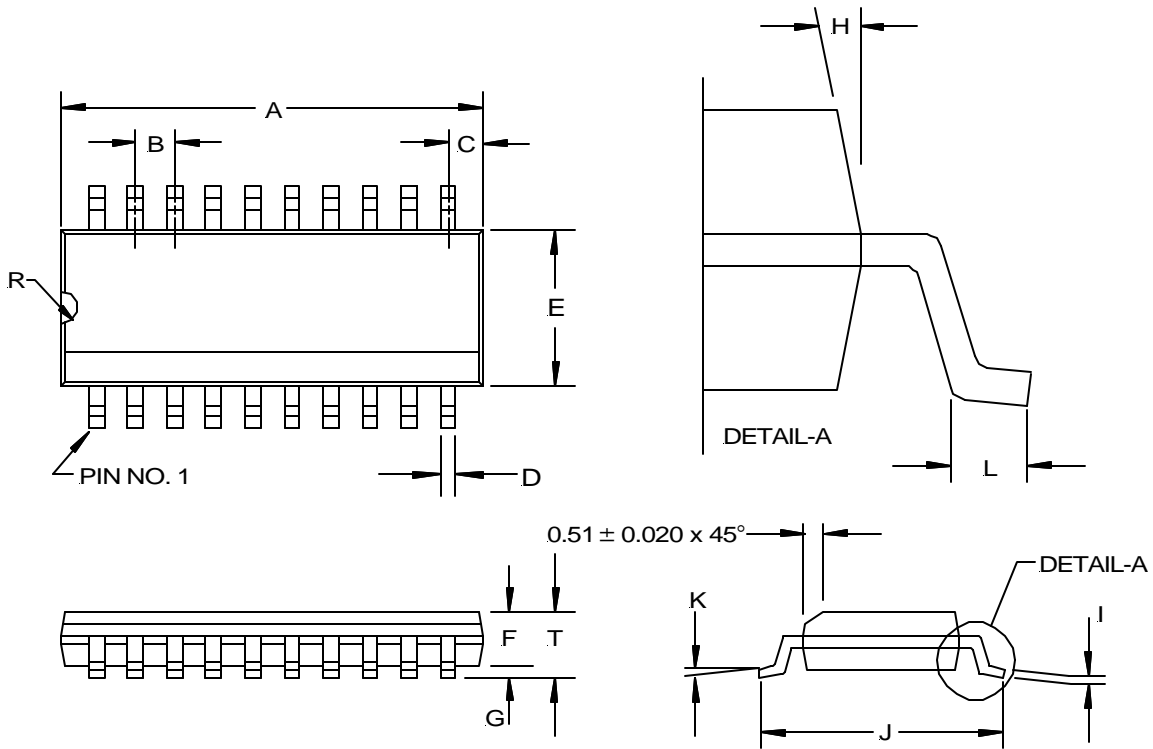

SYMBOL	20-PIN	
	MIN	MAX
A	12.598	12.979
B	1.018	1.524
C	0.66 REF	
D	0.33	0.508
E	7.40	7.60
F	2.032	2.64
G	0.10	0.30
I	0.229	0.32
J	10.008	10.654
K	0°	8°
L	0.406	1.270
R	0.63	0.89
T	2.337	2.642

NOTE: ALL MEASUREMENTS ARE IN MILLIMETERS.

**PACKAGE SHIPMENT METHOD**

PKG DESIG	PACKAGE DESCRIPTION	PIN COUNT	PARTS PER TUBE	PARTS PER REEL	T & R Orientation
W	SOIC, Wide Body	20	38	1000	Fig A

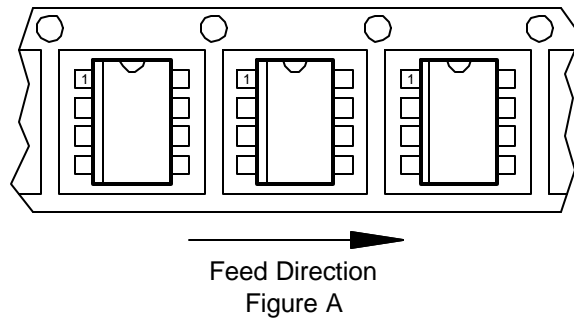



LittleDiode supplies new, hard to find or obsolete electronic components and semiconductors all over the world.

With over two million different components listed you are sure to find the part you need.

Feel free to visit us today at our online store:

**[LittleDiode.com](http://LittleDiode.com)**

Looking forward to providing you with the best possible service.