

## 512K x 8 HIGH-SPEED CMOS STATIC RAM

JULY 2001

### FEATURES

- High-speed access times:  
10, 12 and 15 ns
- High-performance, low-power CMOS process
- Multiple center power and ground pins for greater noise immunity
- Easy memory expansion with  $\overline{CE}$  and  $\overline{OE}$  options
- $\overline{CE}$  power-down
- Fully static operation: no clock or refresh required
- TTL compatible inputs and outputs
- Single 3.3V power supply
- Packages available:
  - 36-pin 400-mil SOJ
  - 36-pin miniBGA
  - 44-pin TSOP (Type II)

### DESCRIPTION

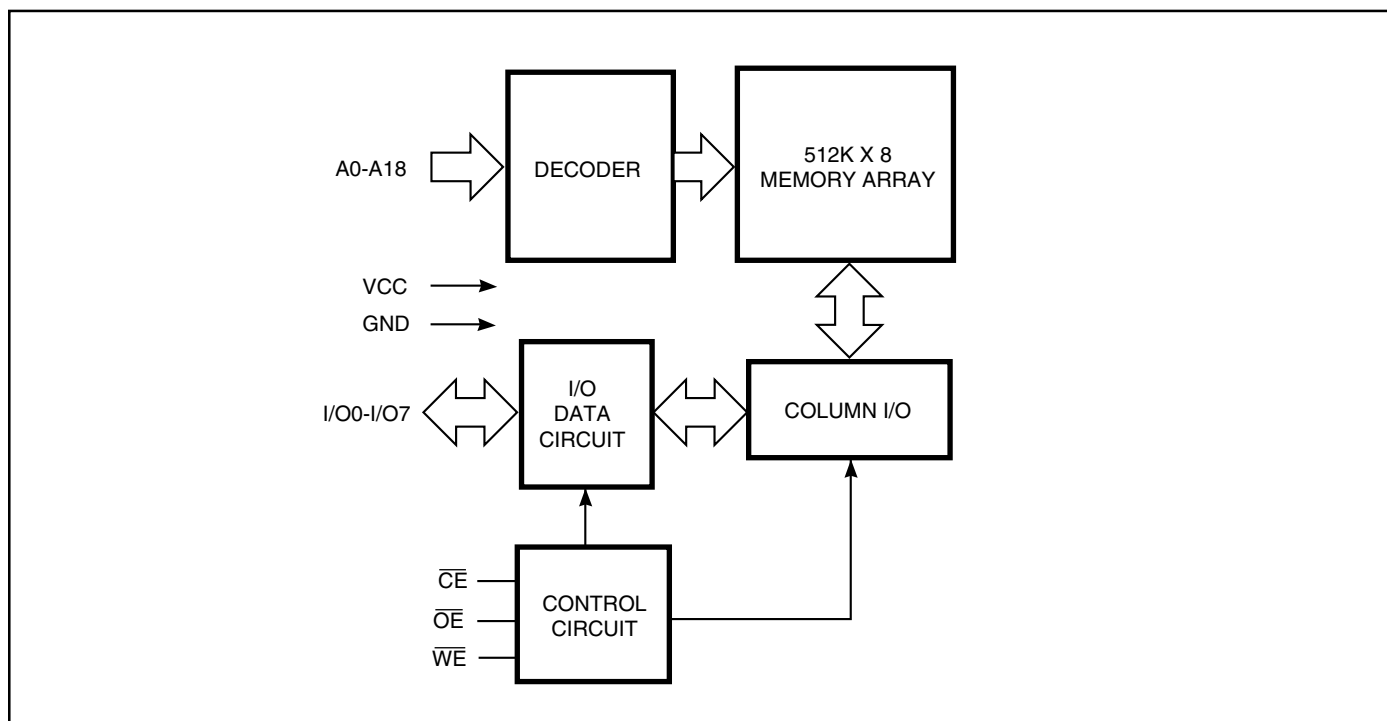
The *ISSI* IS61LV5128 is a very high-speed, low power, 524,288-word by 8-bit CMOS static RAM. The IS61LV5128 is fabricated using *ISSI*'s high-performance CMOS technology. This highly reliable process coupled with innovative circuit design techniques, yields higher performance and low power consumption devices.

When  $\overline{CE}$  is HIGH (deselected), the device assumes a standby mode at which the power dissipation can be reduced down to 250  $\mu$ W (typical) with CMOS input levels.

The IS61LV5128 operates from a single 3.3V power supply and all inputs are TTL-compatible.

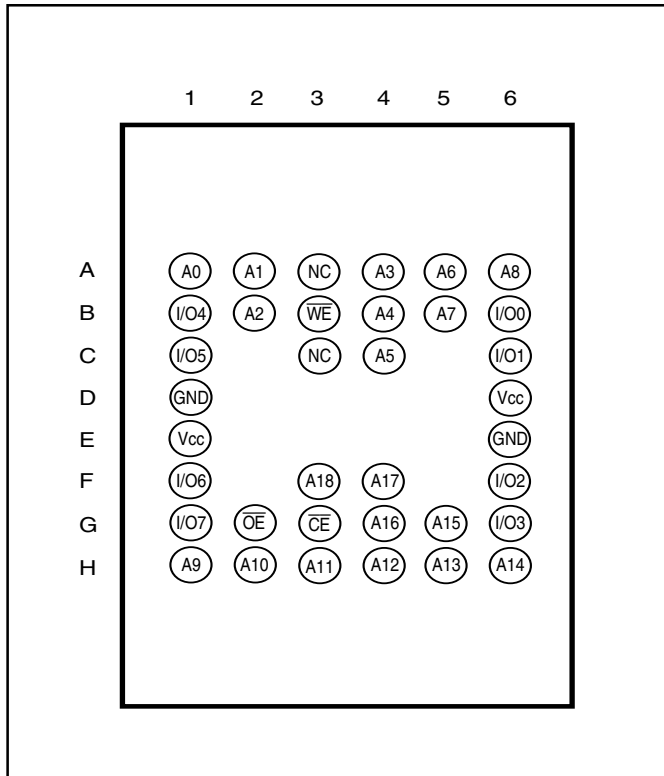
The IS61LV5128 is available in 36-pin 400-mil SOJ, 36-pin mini BGA, and 44-pin TSOP (Type II) packages.

### FUNCTIONAL BLOCK DIAGRAM

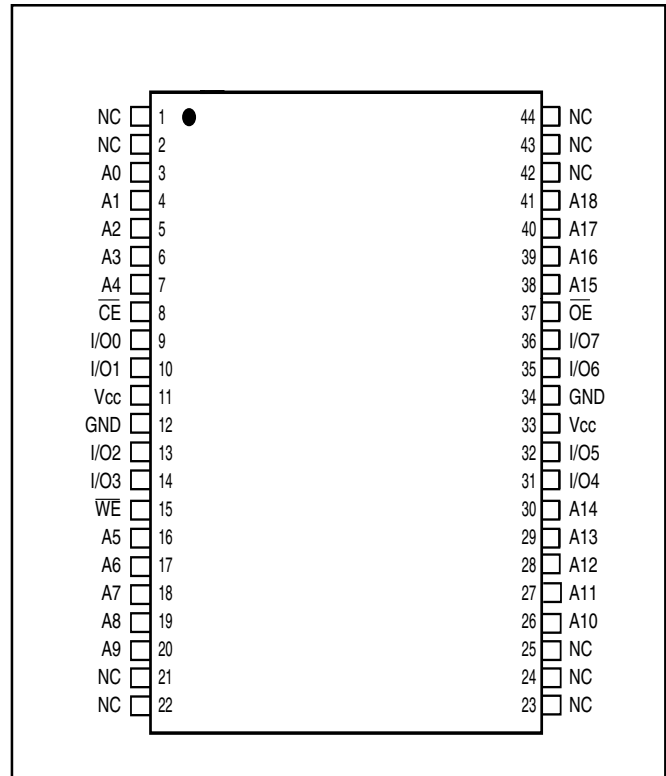


ISSI reserves the right to make changes to its products at any time without notice in order to improve design and supply the best possible product. We assume no responsibility for any errors which may appear in this publication. © Copyright 2000, Integrated Silicon Solution, Inc.

**PIN CONFIGURATION**  
36 mini BGA



**44-Pin TSOP (Type II)**



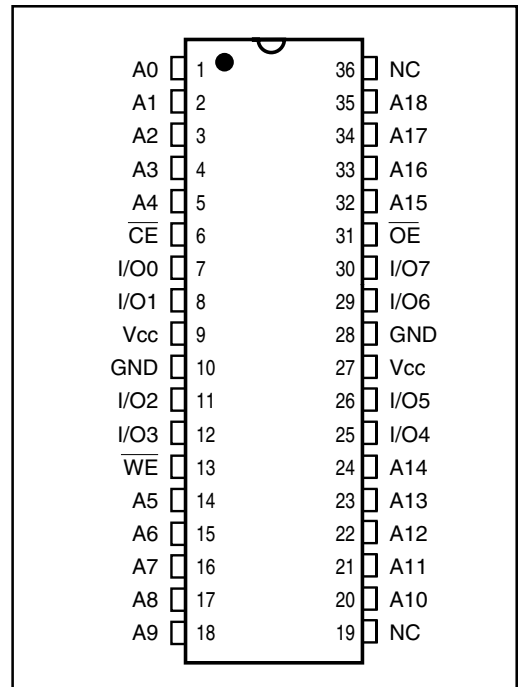
**PIN DESCRIPTIONS**

A0-A18	Address Inputs
$\overline{CE}$	Chip Enable Input
$\overline{OE}$	Output Enable Input
$\overline{WE}$	Write Enable Input
I/O0-I/O7	Bidirectional Ports
Vcc	Power
GND	Ground
NC	No Connection

**TRUTH TABLE**

Mode	$\overline{WE}$	$\overline{CE}$	$\overline{OE}$	I/O Operation	Vcc Current
Not Selected (Power-down)	X	H	X	High-Z	I <sub>SB1</sub> , I <sub>SB2</sub>
Output Disabled	H	L	H	High-Z	I <sub>cc</sub>
Read	H	L	L	DOUT	I <sub>cc</sub>
Write	L	L	X	DIN	I <sub>cc</sub>

**36-Pin SOJ**



**ABSOLUTE MAXIMUM RATINGS<sup>(1)</sup>**

Symbol	Parameter	Value	Unit
V <sub>TERM</sub>	Terminal Voltage with Respect to GND	-0.5 to V <sub>CC</sub> + 0.5	V
T <sub>BIAS</sub>	Temperature Under Bias	-55 to +125	°C
T <sub>STG</sub>	Storage Temperature	-65 to +150	°C
P <sub>T</sub>	Power Dissipation	1.0	W

**Notes:**

1. Stress greater than those listed under ABSOLUTE MAXIMUM RATINGS may cause permanent damage to the device. This is a stress rating only and functional operation of the device at these or any other conditions above those indicated in the operational sections of this specification is not implied. Exposure to absolute maximum rating conditions for extended periods may affect reliability.

**OPERATING RANGE**

Range	Ambient Temperature	10 ns V <sub>CC</sub>	12 ns, 15 ns V <sub>CC</sub>
Commercial	0°C to +70°C	3.3V +10%, -5%	3.3V ± 10%
Industrial	-40°C to +85°C	3.3V +10%, -5%	3.3V ± 10%

**CAPACITANCE<sup>(1,2)</sup>**

Symbol	Parameter	Conditions	Max.	Unit
C <sub>IN</sub>	Input Capacitance	V <sub>IN</sub> = 0V	6	pF
C <sub>I/O</sub>	Input/Output Capacitance	V <sub>OUT</sub> = 0V	8	pF

**Notes:**

1. Tested initially and after any design or process changes that may affect these parameters.
2. Test conditions: T<sub>A</sub> = 25°C, f = 1 MHz, V<sub>CC</sub> = 3.3V.

**DC ELECTRICAL CHARACTERISTICS** (Over Operating Range)

Symbol	Parameter	Test Conditions	Min.	Max.	Unit	
V <sub>OH</sub>	Output HIGH Voltage	V <sub>CC</sub> = Min., I <sub>OH</sub> = -4.0 mA	2.4	—	V	
V <sub>OL</sub>	Output LOW Voltage	V <sub>CC</sub> = Min., I <sub>OL</sub> = 8.0 mA	—	0.4	V	
V <sub>IH</sub>	Input HIGH Voltage		2.0	V <sub>CC</sub> + 0.3	V	
V <sub>IL</sub>	Input LOW Voltage <sup>(1)</sup>		-0.3	0.8	V	
I <sub>LI</sub>	Input Leakage	GND ≤ V <sub>IN</sub> ≤ V <sub>CC</sub>	Com. Ind.	-1 -5	1 5	μA
I <sub>LO</sub>	Output Leakage	GND ≤ V <sub>OUT</sub> ≤ V <sub>CC</sub> , Outputs Disabled	Com. Ind.	-1 -5	1 5	μA

**Note:**

1. V<sub>IL</sub> = -3.0V for pulse width less than 10 ns.

**POWER SUPPLY CHARACTERISTICS<sup>(1)</sup>** (Over Operating Range)

Symbol	Parameter	Test Conditions	-10 ns		-12 ns		-15 ns		Unit	
			Min.	Max.	Min.	Max.	Min.	Max.		
I <sub>CC</sub>	V <sub>CC</sub> Operating Supply Current	V <sub>CC</sub> = Max., $\overline{CE} = V_{IL}$ I <sub>OUT</sub> = 0 mA, f = f <sub>MAX</sub> .	Com.	—	145	—	135	—	125	mA
			Ind.	—	155	—	145	—	135	
I <sub>SB</sub>	TTL Standby Current (TTL Inputs)	V <sub>CC</sub> = Max., V <sub>IN</sub> = V <sub>IH</sub> or V <sub>IL</sub> $\overline{CE} \geq V_{IH}$ , f = f <sub>MAX</sub> .	Com.	—	70	—	60	—	50	mA
			Ind.	—	80	—	70	—	60	
I <sub>SB1</sub>	TTL Standby Current (TTL Inputs)	V <sub>CC</sub> = Max., V <sub>IN</sub> = V <sub>IH</sub> or V <sub>IL</sub> $\overline{CE} \geq V_{IH}$ , f = 0	Com.	—	20	—	20	—	20	mA
			Ind.	—	25	—	25	—	25	
I <sub>SB2</sub>	CMOS Standby Current (CMOS Inputs)	V <sub>CC</sub> = Max., $\overline{CE} \leq V_{CC} - 0.2V$ , V <sub>IN</sub> ≥ V <sub>CC</sub> - 0.2V, or V <sub>IN</sub> ≤ 0.2V, f = 0	Com.	—	10	—	10	—	10	mA
			Ind.	—	15	—	15	—	15	

**Note:**

1. At f = f<sub>MAX</sub>, address and data inputs are cycling at the maximum frequency, f = 0 means no input lines change.

**READ CYCLE SWITCHING CHARACTERISTICS<sup>(1)</sup>** (Over Operating Range)

Symbol	Parameter	-10 ns		-12 ns		-15 ns		Unit
		Min.	Max.	Min.	Max.	Min.	Max.	
t <sub>RC</sub>	Read Cycle Time	10	—	12	—	15	—	ns
t <sub>AA</sub>	Address Access Time	—	10	—	12	—	15	ns
t <sub>OHA</sub>	Output Hold Time	3	—	3	—	3	—	ns
t <sub>ACE</sub>	$\overline{\text{CE}}$ Access Time	—	10	—	12	—	15	ns
t <sub>DOE</sub>	$\overline{\text{OE}}$ Access Time	—	4	—	5	—	7	ns
t <sub>LZOE<sup>(2)</sup></sub>	$\overline{\text{OE}}$ to Low-Z Output	0	—	0	—	0	—	ns
t <sub>HZOE<sup>(2)</sup></sub>	$\overline{\text{OE}}$ to High-Z Output	0	4	0	5	0	6	ns
t <sub>LZCE<sup>(2)</sup></sub>	$\overline{\text{CE}}$ to Low-Z Output	3	—	3	—	3	—	ns
t <sub>HZCE<sup>(2)</sup></sub>	$\overline{\text{CE}}$ to High-Z Output	0	4	0	6	0	8	ns
t <sub>PU</sub>	Power Up Time	0	—	0	—	0	—	ns
t <sub>PD</sub>	Power Down Time	—	10	—	12	—	15	ns

**Notes:**

1. Test conditions assume signal transition times of 3 ns or less, timing reference levels of 1.5V, input pulse levels of 0 to 3.0V and output loading specified in Figure 1.
2. Tested with the load in Figure 2. Transition is measured  $\pm 500$  mV from steady-state voltage. Not 100% tested.

**AC TEST CONDITIONS**

Parameter	Unit
Input Pulse Level	0V to 3.0V
Input Rise and Fall Times	3 ns
Input and Output Timing and Reference Levels	1.5V
Output Load	See Figures 1 and 2

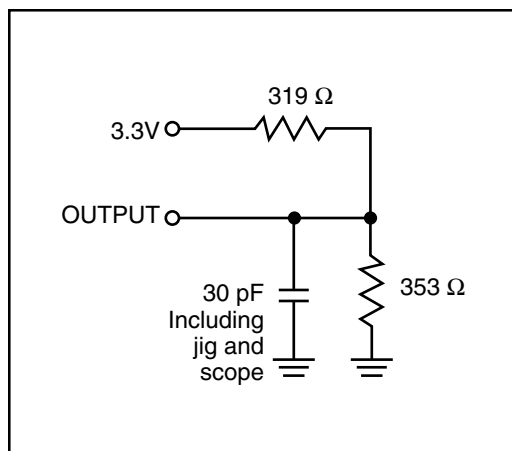
**AC TEST LOADS**

Figure 1

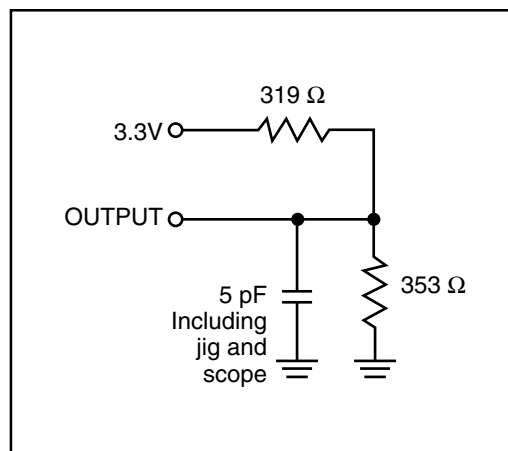
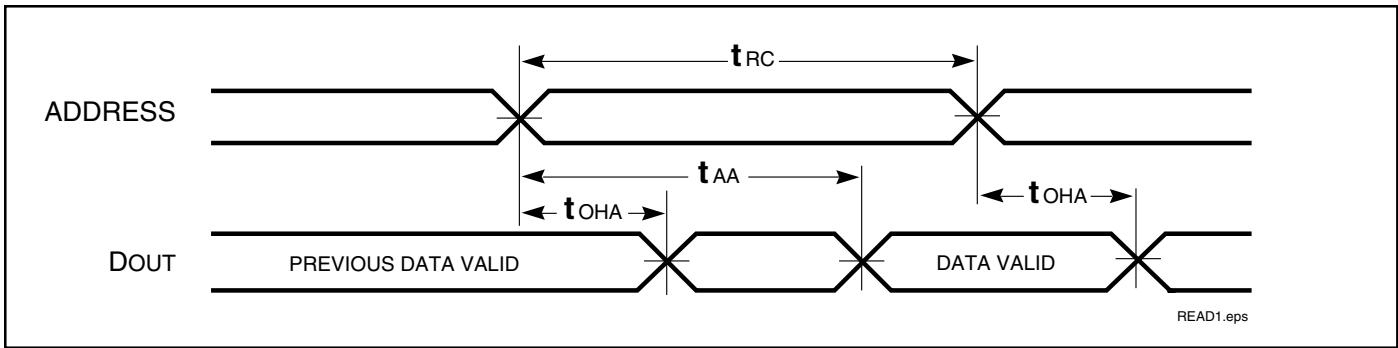


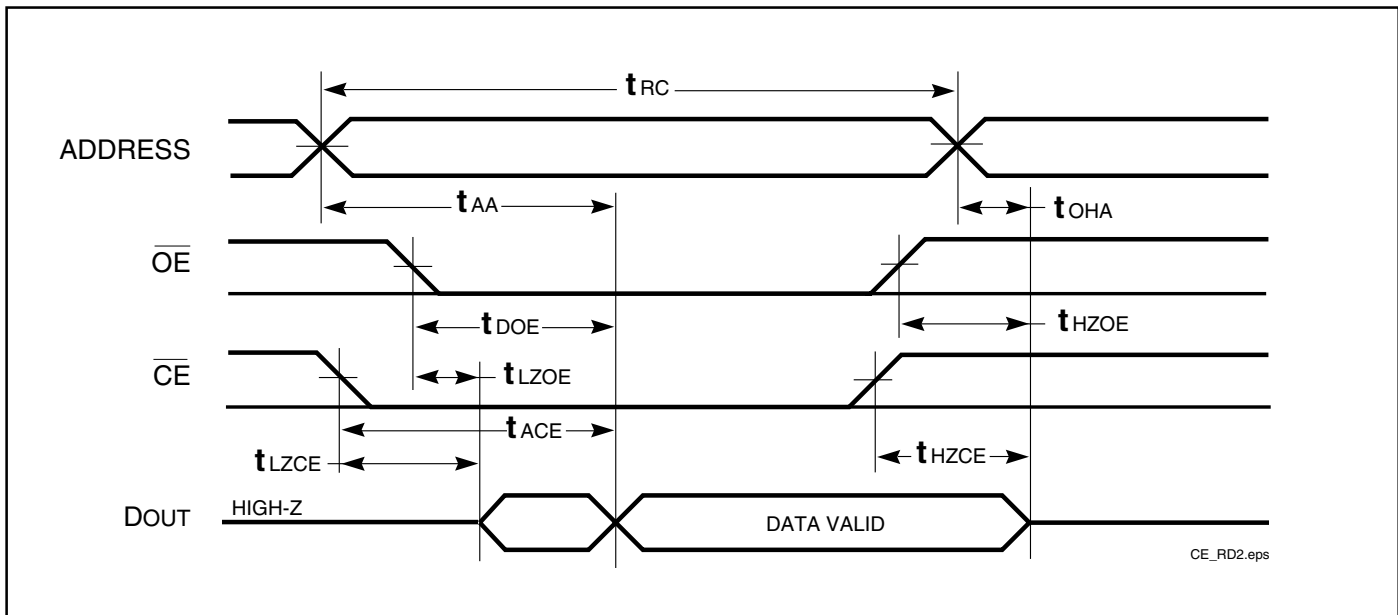
Figure 2

**AC WAVEFORMS**

**READ CYCLE NO. 1<sup>(1,2)</sup>** (Address Controlled) ( $\overline{CE} = \overline{OE} = V_{IL}$ )



**READ CYCLE NO. 2<sup>(1,3)</sup>** ( $\overline{CE}$  and  $\overline{OE}$  Controlled)



**Notes:**

1.  $\overline{WE}$  is HIGH for a Read Cycle.
2. The device is continuously selected.  $\overline{OE}$ ,  $\overline{CE} = V_{IL}$ .
3. Address is valid prior to or coincident with  $\overline{CE}$  LOW transitions.

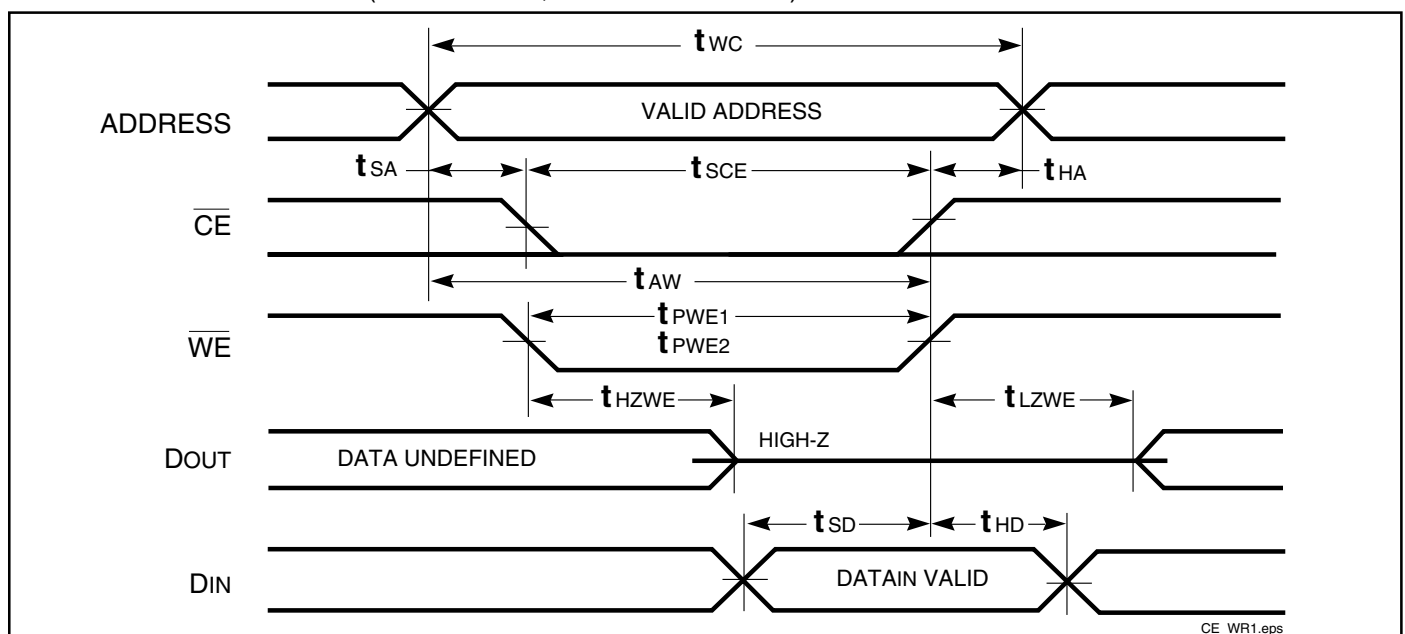
WRITE CYCLE SWITCHING CHARACTERISTICS<sup>(1,3)</sup> (Over Operating Range)

Symbol	Parameter	-10 ns		-12 ns		-15 ns		Unit
		Min.	Max.	Min.	Max.	Min.	Max.	
t <sub>wc</sub>	Write Cycle Time	10	—	12	—	15	—	ns
t <sub>sce</sub>	$\overline{CE}$ to Write End	8	—	9	—	10	—	ns
t <sub>aw</sub>	Address Setup Time to Write End	8	—	9	—	10	—	ns
t <sub>ha</sub>	Address Hold from Write End	0	—	0	—	0	—	ns
t <sub>sa</sub>	Address Setup Time	0	—	0	—	0	—	ns
t <sub>pwe1</sub> <sup>(4)</sup>	$\overline{WE}$ Pulse Width	8	—	8	—	10	—	ns
t <sub>pwe2</sub>	$\overline{WE}$ Pulse Width ( $\overline{OE} = \text{LOW}$ )	10	—	12	—	12	—	ns
t <sub>sd</sub>	Data Setup to Write End	6	—	6	—	7	—	ns
t <sub>hd</sub>	Data Hold from Write End	0	—	0	—	0	—	ns
t <sub>hzwe</sub> <sup>(2)</sup>	$\overline{WE}$ LOW to High-Z Output	0	5	0	6	0	7	ns
t <sub>lzwe</sub> <sup>(2)</sup>	$\overline{WE}$ HIGH to Low-Z Output	0	—	0	—	0	—	ns

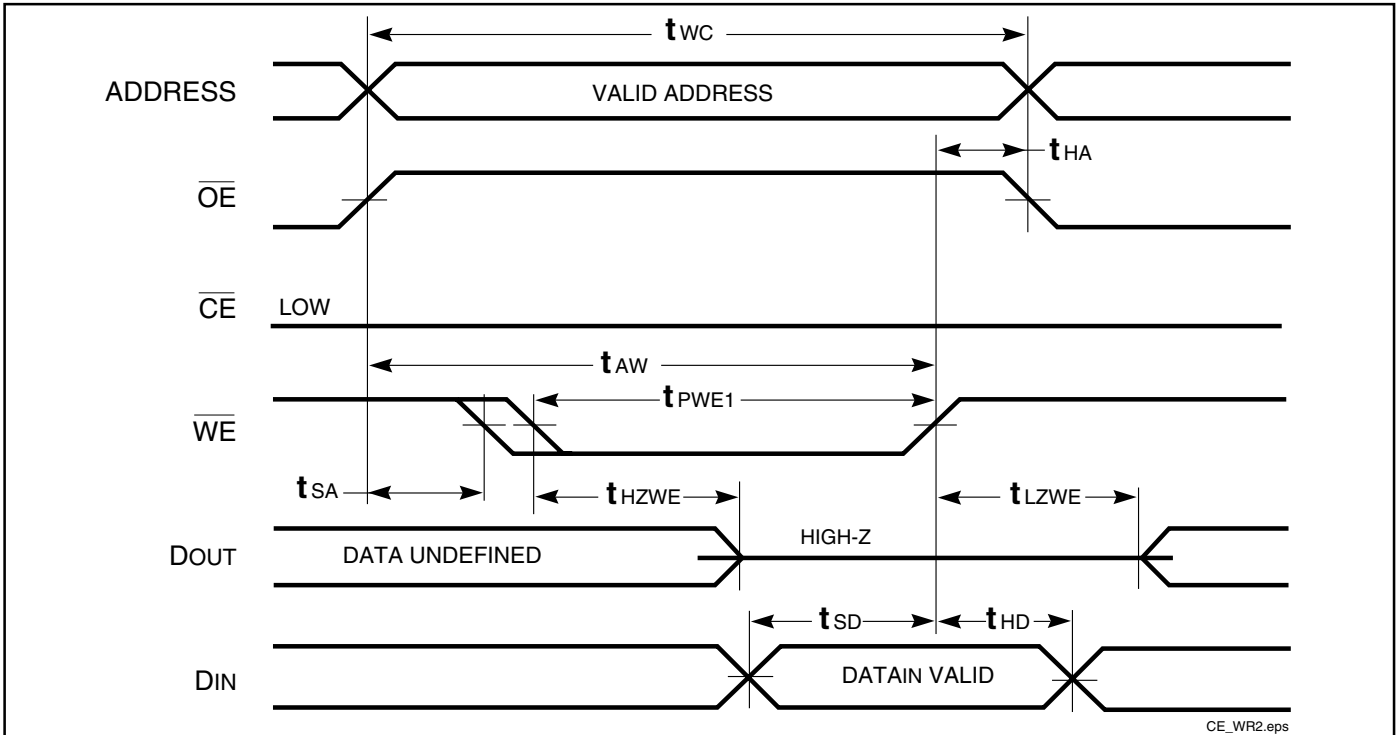
## Notes:

1. Test conditions assume signal transition times of 3 ns or less, timing reference levels of 1.5V, input pulse levels of 0 to 3.0V and output loading specified in Figure 1.
2. Tested with the load in Figure 2. Transition is measured  $\pm 500$  mV from steady-state voltage. Not 100% tested.
3. The internal write time is defined by the overlap of  $\overline{CE}$  LOW and  $\overline{WE}$  LOW. All signals must be in valid states to initiate a Write, but any one can go inactive to terminate the Write. The Data Input Setup and Hold timing are referenced to the rising or falling edge of the signal that terminates the Write.
4. Tested with  $\overline{OE}$  HIGH.

## AC WAVEFORMS

WRITE CYCLE NO. 1<sup>(1,2)</sup> ( $\overline{CE}$  Controlled,  $\overline{OE} = \text{HIGH or LOW}$ )

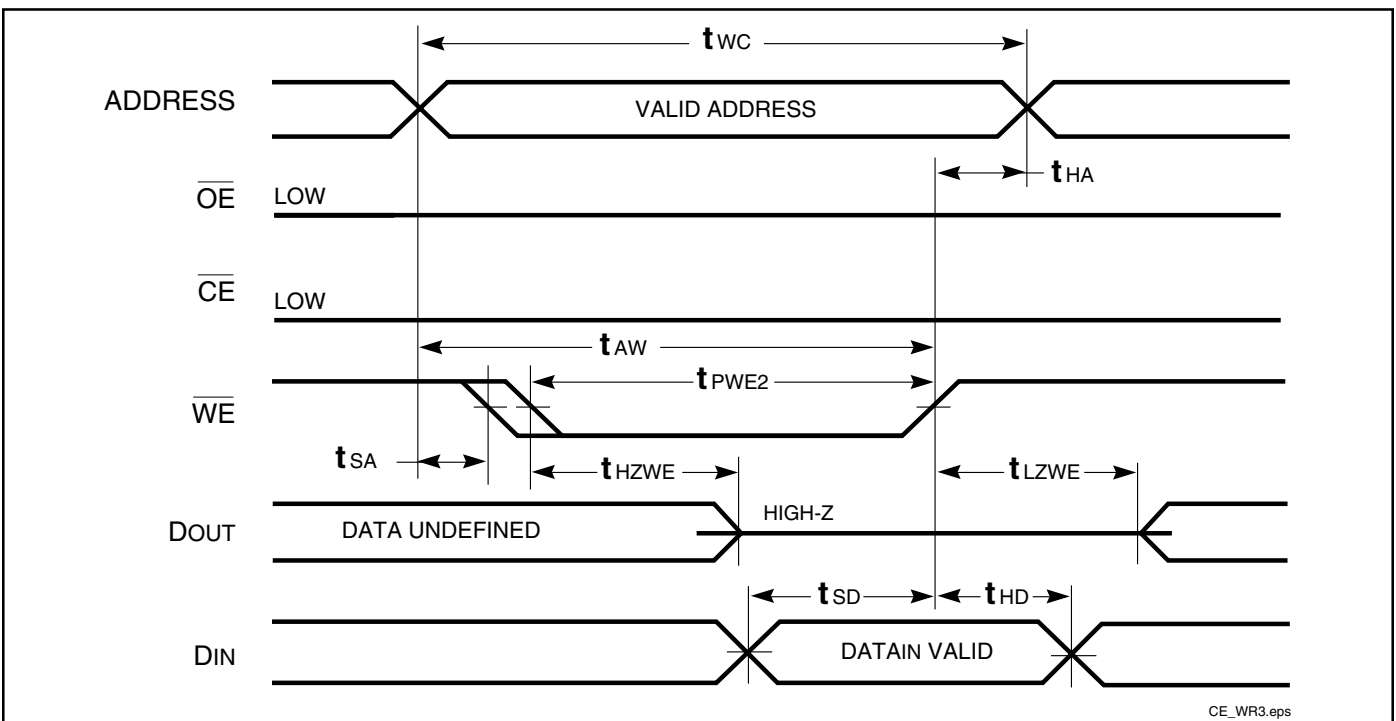
**WRITE CYCLE NO. 2<sup>(1,2)</sup>** ( $\overline{WE}$  Controlled:  $\overline{OE}$  is HIGH During Write Cycle)



**Notes:**

1. The internal write time is defined by the overlap of  $\overline{CE}$  LOW and  $\overline{WE}$  LOW. All signals must be in valid states to initiate a Write, but any one can go inactive to terminate the Write. The Data Input Setup and Hold timing are referenced to the rising or falling edge of the signal that terminates the Write.
2. I/O will assume the High-Z state if  $\overline{OE} \cdot V_{IH}$ .

**WRITE CYCLE NO. 3** ( $\overline{WE}$  Controlled:  $\overline{OE}$  is LOW During Write Cycle)



**ORDERING INFORMATION****Commercial Range: 0°C to +70°C**

Speed (ns)	Order Part No.	Package
10	IS61LV5128-10K	400-mil Plastic SOJ
10	IS61LV5128-10T	TSOP (Type II)
10	IS61LV5128-10B	mini BGA (8mmx10mm)
12	IS61LV5128-12K	400-mil Plastic SOJ
12	IS61LV5128-12T	TSOP (Type II)
12	IS61LV5128-12B	mini BGA (8mmx10mm)
15	IS61LV5128-15K	400-mil Plastic SOJ
15	IS61LV5128-15T	TSOP (Type II)
15	IS61LV5128-15B	mini BGA (8mmx10mm)

**Industrial Range: -40°C to +85°C**

Speed (ns)	Order Part No.	Package
10	IS61LV5128-10KI	400-mil Plastic SOJ
10	IS61LV5128-10TI	TSOP (Type II)
10	IS61LV5128-10BI	mini BGA (8mmx10mm)
12	IS61LV5128-12KI	400-mil Plastic SOJ
12	IS61LV5128-12TI	TSOP (Type II)
12	IS61LV5128-12BI	mini BGA (8mmx10mm)
15	IS61LV5128-15KI	400-mil Plastic SOJ
15	IS61LV5128-15TI	TSOP (Type II)
15	IS61LV5128-15BI	mini BGA (8mmx10mm)

**ISSI®**

**Integrated Silicon Solution, Inc.**

2231 Lawson Lane  
 Santa Clara, CA 95054  
 Tel: 1-800-379-4774  
 Fax: (408) 588-0806  
 E-mail: sales@issi.com  
[www.issi.com](http://www.issi.com)

This datasheet has been downloaded from:

[www.DatasheetCatalog.com](http://www.DatasheetCatalog.com)

Datasheets for electronic components.



LittleDiode supplies new, hard to find or obsolete electronic components and semiconductors all over the world.

With over two million different components listed you are sure to find the part you need.

Feel free to visit us today at our online store:

[LittleDiode.com](http://LittleDiode.com)

Looking forward to providing you with the best possible service.