

## Synchronizing Current Mode PWM for Subscriber Line Interface Circuits (SLICs)

The ISL6401 adjustable frequency, low power, pulse width modulating (PWM) current mode controller is designed for a wide range of DC-DC conversion applications including boost, flyback, and isolated output configurations. The device is optimized to provide a high performance, low-cost solution for Ringing SLIC (RSLIC) ring and talk power supplies. An integrated inverter allows for easy design of negative voltage regulation circuits with a minimal amount of external components. Internal soft start minimizes start-up stress without any external components. Peak current mode control effectively handles Ring trip transients and provides inherent over-current protection.

This advanced BiCMOS design features low operating current, adjustable operating output frequency (50kHz to 600kHz), internal soft-start and a SYNC input that allows the oscillator to be locked to an external clock for noise sensitive applications. DC-DC conversion efficiency is optimized by use of a low current sense voltage. A logic level shutdown input is included, which reduces supply current to 55µA in the shutdown mode.

### Ordering Information

PART NUMBER	TEMP. RANGE (°C)	PACKAGE	PKG. DWG. #
ISL6401CB	0 to 70	14 Ld SOIC	M14.15
ISL6401IB	-40 to 85	14 Ld SOIC	M14.15
ISL6401CR	0 to 70	16 Ld QFN	L16.4x4
ISL6401IR	-40 to 85	16 Ld QFN	L16.4x4

Add -T suffix for tape and reel packaging.

### Pinouts

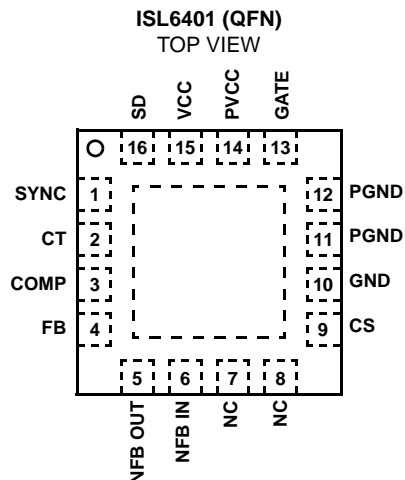
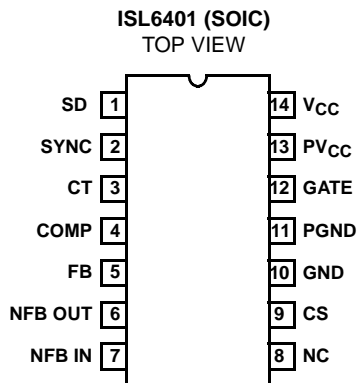

### Features

- Positive and Negative Output Regulation
- Starting Supply Current . . . . . 100µA (typ.)
- Quiescent Current . . . . . 55µA (typ.)
- Output Frequency Range . . . . . 50kHz to 600kHz
- External Clock Synchronization
- Fast Transient Response with Peak Current Mode Control
- Internal Soft-Start
- Drives N-Channel MOSFET
- Logic Level Shutdown
- Leading Edge Blanking
- 1% Tolerance Voltage Reference Over Line and Temperature

### Applications

- VoIP/VoDSL Ringer and Off-Hook Voltage Generators
- Multi-Output Flyback Supplies
- Cable and DSL Modems
- Set-Top Boxes
- Wireless Local Loops
- LMDH and FTTH Supplies
- Boost Regulators
- Routers

Functional Block Diagram

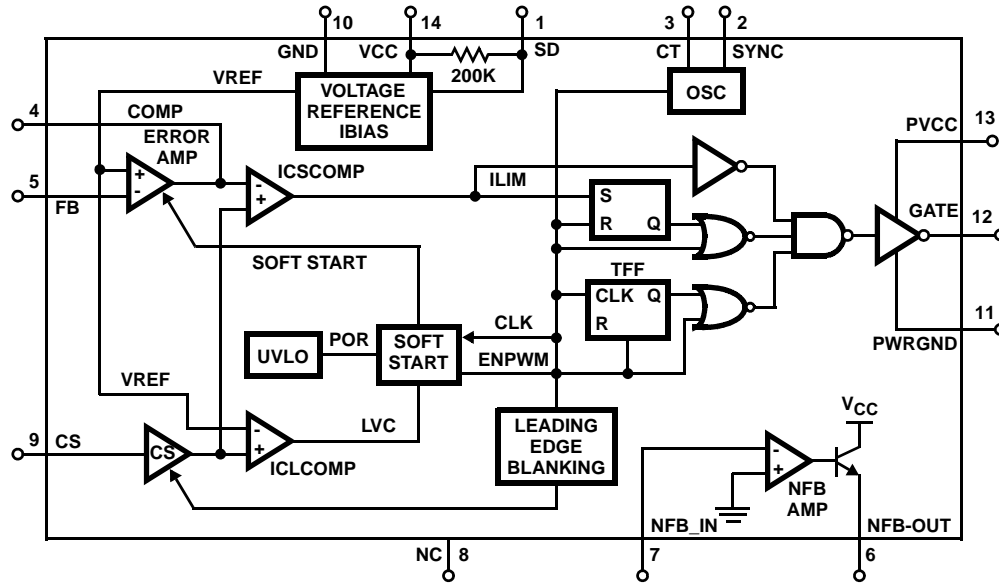

Typical Application Schematic for 4 Line VoIP

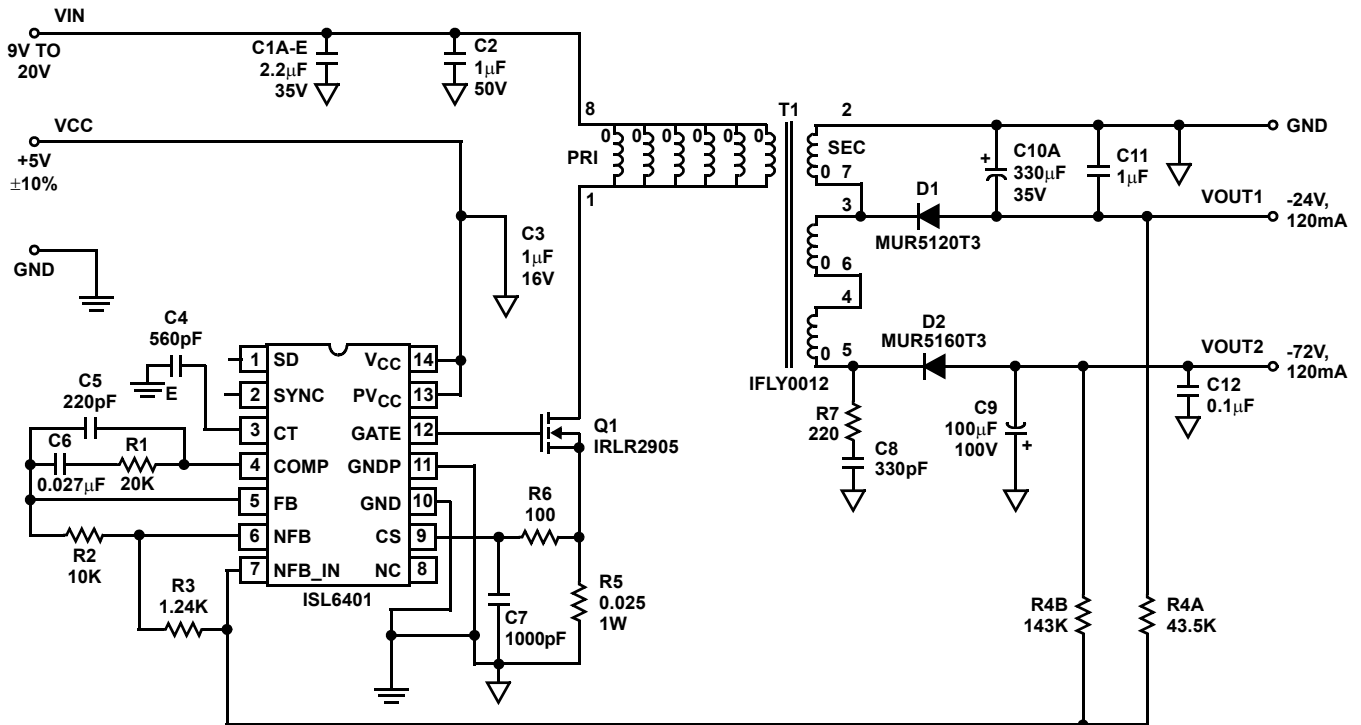

NOTES:

1. C2 fit as close as possible to transformer.
2. T1 = IFLY0012 contacts: Coilcraft: (847) 516-7377 GCI Technology: (972) 423-8411 ext. 245
3. For custom specific designs or questions please contact Intersil at (321) 724-7840.

**Absolute Maximum Ratings**

Supply Voltage,  $V_{CC}, PV_{CC}$  ..... GND -0.3V to +7.0V  
 PGND to GND .....  $\pm 0.3V$   
 Peak GATE Current ..... 1A  
 ESD Classification ..... Class 1 (HBM, 2500V)  
 NFB Pin Voltage .....  $\pm 10V$  (Transient, 10ms)

**Operating Conditions**

Temperature Range  
 ISL6401C ..... 0°C to 70°C  
 ISL6401I ..... -40°C to 85°C  
 Supply Voltage Range (Typical) ..... 5V  $\pm 10\%$

**Thermal Information**

Thermal Resistance (Typical)  $\theta_{JA}$  (°C/W)  $\theta_{JC}$  (°C/W)  
 14 Lead SOIC (Note 4) ..... 90 NA  
 16 Lead QFN (Note 5) ..... 46 9  
 Maximum Junction Temperature (Plastic Package) -55°C to 150°C  
 Maximum Storage Temperature Range ..... -65°C to 150°C  
 Maximum Lead Temperature (Soldering 10s) ..... 300°C  
 (SOIC - Lead Tips Only)  
 For Recommended soldering conditions see Tech Brief TB389.

*CAUTION: Stresses above those listed in "Absolute Maximum Ratings" may cause permanent damage to the device. This is a stress only rating and operation of the device at these or any other conditions above those indicated in the operational sections of this specification is not implied.*

**NOTES:**

4.  $\theta_{JA}$  is measured with the component mounted on a high effective thermal conductivity test board in free air. See Tech Brief TB379 for details.
5.  $\theta_{JA}$  is measured in free air with the component mounted on a high effective thermal conductivity test board with "direct attach" features.  $\theta_{JC}$ , the "case temp" is measured at the center of the exposed metal pad on the package underside. See Tech Brief TB379.
6. All voltages are with respect to GND.

**Electrical Specifications** Recommended operating conditions unless otherwise noted. Refer to Block Diagram and Typical Application schematic.  $V_{CC} = +5.0V \pm 10\%$ ,  $T_A = 0$  to 70°C for ISL6401C and  $T_A = -40$  to 85°C for ISL6401I (Note 7), Typical values are at  $T_A = 25^\circ C$

PARAMETER	TEST CONDITIONS	MIN	TYP	MAX	UNITS
<b>V<sub>CC</sub> SUPPLY</b>					
Supply Voltage Range		4.5	5.0	5.5	V
Shutdown Supply Current	SHDN = GND	-	55	100	μA
Start-Up Current	$V_{CC} < 3.7V$	-	0.1	0.20	mA
Operating Supply Current	(Note 8)	-	3.7	6.0	mA
<b>REFERENCE VOLTAGE</b>					
Output Voltage		1.237	1.25	1.262	V
Long Term Stability	$T_A = 125^\circ C$ , 1000 hours	-	5	-	mV
<b>NEGATIVE FEEDBACK</b>					
Source Current		-	1.0	2.0	mA
<b>CURRENT SENSE</b>					
Maximum Input Signal		0.2	0.260	0.3	V
Input Bias Current		-2.0	0.0	2.0	μA
Over Current Threshold		0.4	0.52	0.6	V
<b>ERROR AMPLIFIER</b>					
Open Loop Voltage Gain		-	78	-	dB
Gain-Bandwidth Product		10	-	-	MHz
Input Voltage		1.225	1.25	1.275	V
Input Bias Current		-	1.0	-	μA
<b>PWM</b>					
Maximum Duty Cycle		47	48	50	%
Minimum Duty Cycle	COMP = 0V	-	0	-	%

**Electrical Specifications** Recommended operating conditions unless otherwise noted. Refer to Block Diagram and Typical Application schematic.  $V_{CC} = +5.0V \pm 10\%$ ,  $T_A = 0$  to  $70^\circ C$  for ISL6401C and  $T_A = -40$  to  $85^\circ C$  for ISL6401I (Note 7), Typical values are at  $T_A = 25^\circ C$  (Continued)

PARAMETER	TEST CONDITIONS	MIN	TYP	MAX	UNITS
<b>UNDERVOLTAGE LOCKOUT</b>					
Start Threshold		3.7	4.1	4.3	V
Stop Threshold		3.2	3.6	4.0	V
Start to Stop Hysteresis		0.2	0.5	0.8	V
<b>SOFT START - DIGITAL</b>					
COMP Rise Time	Rise from 0.5V to REF -1V	-	2048 clk	-	
<b>OSCILLATOR</b>					
Gate Output Frequency	Ct = 560pF	90	100	108	kHz
Gate Output Frequency Range		50	-	600	kHz
Temperature Stability		-	5	-	%
Sync. Frequency Range	1.1 Times the natural switching frequency.	-	-	1.2	MHz
Sync Input HIGH		3.5	-	-	V
Sync Input LOW		-	-	1.5	V
Minimum Sync. Input Pulse Duty Cycle		-	20	-	%
<b>OUTPUT</b>					
GATE Low Level		-	0.2	0.5	V
GATE High $V_{SAT}$		4.4	4.9	5.5	V
Rise Time	C load = 1500pF	-	35	-	ns
Fall Time	C load = 1500pF	-	40	-	ns

NOTE:

- 7. Specifications at  $-40^\circ C$  are guaranteed by design, not production tested.
- 8. This is the  $V_{CC}$  current consumed when the device is active but not switching. Does not include gate drive current.

**Typical Performance Curves**

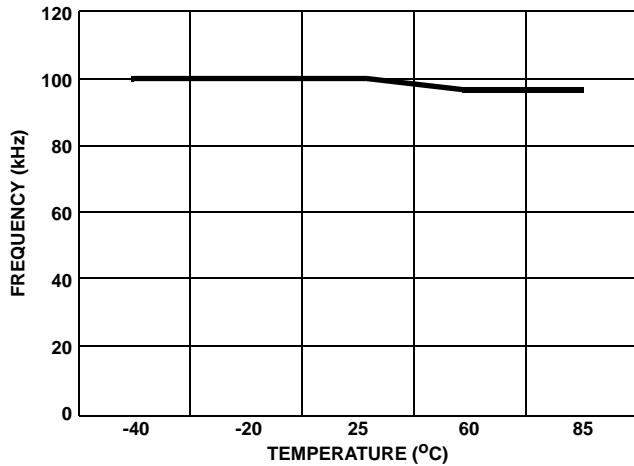

FIGURE 1. FREQUENCY vs TEMPERATURE

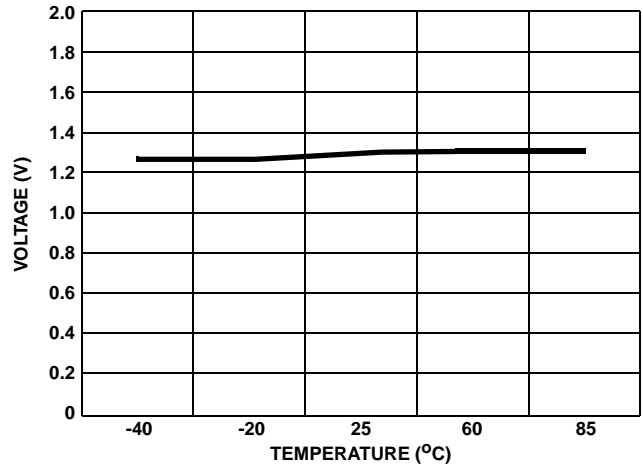

FIGURE 2. REFERENCE VOLTAGE vs TEMPERATURE

## Typical Performance Curves (Continued)

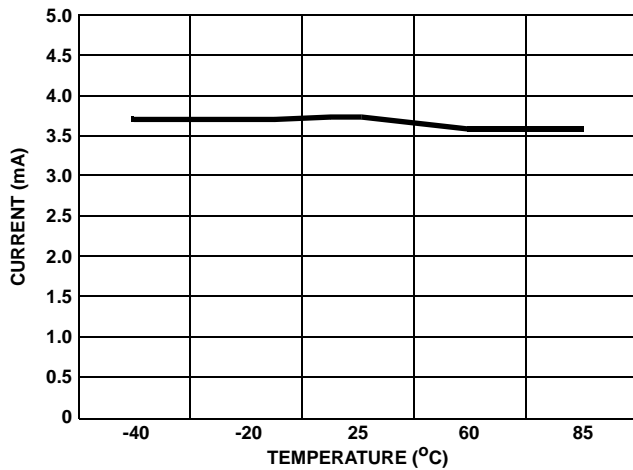

FIGURE 3. SUPPLY CURRENT vs TEMPERATURE

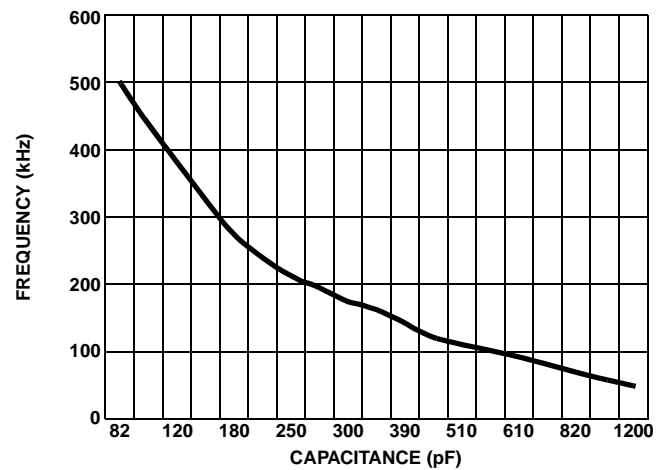

FIGURE 4. CAPACITANCE vs FREQUENCY

### Pin Descriptions

**SD** - This pin is logic level compatible and can be pulled high, tied to  $V_{IN}$  or left open for normal operation. Logic low on the SD activates shutdown, reducing the part's supply current to approximately  $55\mu A$ .

**SYNC** - This pin is the input pin for external frequency synchronization. The switching frequency of the device can be synchronized by an external clock signal inserted at this pin. The oscillator timing capacitor,  $C_T$ , is still required, even if an external clock is used. Program the free-running frequency to be a minimum of 10% slower than the SYNC input frequency.

**CT** - This is the oscillator timing pin. The free-running frequency can be set by connecting a timing capacitor to this pin. The oscillator produces a sawtooth waveform with a programmable frequency range of 100kHz to 1.2MHz. Figure 4 may be used as a guideline in selecting the capacitor value required for a given frequency.

**COMP** - COMP is the output of the error amplifier and input of the current comparator.

The ISL6401 features built-in full cycle soft start. Soft start is implemented as a clamp on the maximum COMP voltage.

**FB** - Feedback pin that is used for positive output voltage sensing. It is the inverting input of the error amplifier. The non-inverting input of the error amplifier is internally tied to a reference voltage.

**NFB-IN** - Negative feedback pin that is used for negative output voltage sensing. It is connected to the inverting input of the negative feedback amplifier through a 100K source resistor.

**NFB OUT** - This pin is the output of the negative feedback inverter. This pin should be connected the FB pin with a 10k

series resistor for negative output voltage regulation applications.

**CS** - This is the input of the current sense comparator. The IC has two different comparators: The PWM comparator and an overcurrent comparator.

The over current comparator is only intended for fault sensing, and exceeding the over-current threshold will cause a soft start cycle.

**GND** - GND is a small signal reference ground for all analog functions on this part.

**PGND** - This pin provides a dedicated ground for the output gate driver. The GND and PGND pins should be connected externally using a short printed circuit board trace close to the IC. This is imperative to prevent large, high frequency switching currents flowing through the ground metallization inside the IC. (Decouple  $PV_{CC}$  to PGND with a low ESR  $0.1\mu F$  capacitor.)

**GATE** - This is the device output. It is a high current power driver capable of driving the gate of a power MOSFET with peak currents exceeding 1.0A. This GATE output is actively held low when  $V_{CC}$  is below the UVLO threshold (3.7V typ).

The high-current power driver consists of FET output devices, which can switch all the way to GND and all the way to  $V_{CC}$ . The output stage also provides very low impedance to overshoot and undershoot.

**PVCC** - This pin is for separate collector supply to the output gate drive. Separate  $PV_{CC}$  and PGnd helps decouple the IC's analog circuitry from the high power gate drive noise. Connect this pin to  $V_{CC}$  with external short trace on printed circuit board.

**VCC** -  $V_{CC}$  is the power connection for the device. Although quiescent  $V_{CC}$  current is very low, total supply current will be

higher, depending on the output current. Total  $V_{CC}$  current is the sum of the quiescent  $V_{CC}$  current and the average output current. Knowing the operating frequency and the MOSFET gate charge (Qg), average output current can be calculated from:

$$I_{OUT} = Qg \times F$$

To prevent noise problems, bypass  $V_{CC}$  to GND with a ceramic capacitor as close to the  $V_{CC}$  pin as possible. An electrolytic capacitor may also be used in addition to the ceramic capacitor.

## Functional Description

### Features

The ISL6401 current mode, synchronizable PWM, makes an ideal choice for low-cost, low-power, multi-output flyback topology applications with low input-output ripple current requirements. When configured in a multi-winding flyback topology, the IC is capable of generating the negative Talk and Ring voltages required for Ringing Subscriber Line Interface (RSLIC) power supplies. This approach provides dual outputs from a single power switch and control IC. Low current sense voltage and shutdown mode leads to high efficiency operation. Other features include peak current mode control, internal soft-start, adjustable current limit, adjustable frequency and external frequency synchronization.

### Oscillator

The ISL6401 has an internal sawtooth oscillator with a programmable frequency range of 100kHz to 1MHz, which can be programmed with a capacitor on the CT pin. (Please refer to Fig. 4 for the capacitance required for a given frequency.) With a maximum 50% duty cycle operation, the output switching frequency is half the oscillator frequency.

### Implementing Synchronization

The oscillator can be synchronized by an external clock inserted at the SYNC pin. Program the free running frequency of the oscillator to be 10% slower than the desired synchronous frequency. The external clock signal should have a minimum pulse width of 20ns.

### Soft Start Operation

The ISL6401 features an internal digital soft-start with no external capacitor required. Soft-start is used to reduce transformer and output capacitor stress and to reduce the surge on the input circuits, when the converter action starts. The considerable capacitance on the output lines should be charged slowly, so as not to reflect an excessive transient. A very wide initial pulse could result in saturation of the core and voltage overshoot on the output, if the inductor current is allowed to rise to a high value during start up.

Upon start-up, the peak primary current increments from 1/5th of the value set by  $R_{CS}$  to the full current limit value in steps, over 2048 cycles of  $F_{osc}$  or  $F_{sync}$ . Soft-start clamps

the error amplifier output (COMP pin) and the reference input (non-inverting terminal of the error amplifier) to the internally generated soft-start voltage. The oscillator sawtooth waveform is compared to the ramping error amplifier voltage. This generates GATE pulses of increasing width that charge the output capacitor(s). With sufficient output voltage, the clamp on the reference input controls the output voltage. When the internally generated soft-start voltage exceeds the FB pin voltage, the output voltage is in regulation. This method provides a rapid, controlled output voltage rise. Soft-start is implemented during start-up, after an over-current has cleared, or when exiting shutdown or under voltage lock-out (UVLO).

### Gate Drive

The ISL6401 is capable of sourcing 1A of peak-drive current. Separate collector supply ( $PV_{CC}$ ) and power ground (PGnd) pins help isolate the IC's analog circuitry from the high power gate drive noise. To limit the peak current through the IC, an external resistor is placed between the totem-pole output of the IC and the gate of the MOSFET. The minimum value of this resistor is determined by:

$$R_{gate} = (V_{dd(min)} - V_{sat}) / I_{gate(peak)}$$

This small series resistor also damps any oscillations caused by the resonant tank of the parasitic inductances in the traces of the board and the FET's input capacitance. A pull-down resistor is sometimes added to the gate drive to insure the MOSFET gate does not get charged to its turn-on threshold during device start-up. Adding a fast-switching diode and smaller value resistor in parallel with the gate resistor helps to control the current the IC needs to sink during turn-off and protects the output stage of the device. These components also help to reduce turn-off losses, which tend to dominate the switching losses in discontinuous current-mode (DCM) converters.

### Ground Plane Requirements

Careful layout is essential for correct operation of the device. A good ground plane must be employed. A unique section of the ground plane must be designated for high di/dt currents associated with the output stage. Power ground (PGND) can be separated from the analog ground (GND) and connected at a single point.  $V_{CC}$  should be bypassed directly to PGND with good high frequency capacitors. The return connection for input power to the system and the bulk input capacitor should be connected to the PGND ground plane.

## Application Information

### Subscriber Line Interface Circuit Requirements

As worldwide demand for inexpensive Voice over Internet Protocol telephony grows, so will the need for ICs that enable compatibility between new telephony systems and older telephones based on analog standards. Old style telephones require signal and power inputs that are not generally available on purely digital systems. Analog ring

signal generation and off-hook loop current supply are two analog functions that are performed by Subscriber Line Interface Circuits (SLICs). A SLIC is the primary interface between the 4-wire (ground referenced) low voltage switch environment and the 2 wire (floating) high voltage loop environment. It performs a number of important functions including battery feed, over-voltage protection, ringing, signaling, coding, hybrid balancing and testing.

The Ringing SLIC (RSLIC) typically requires two high voltage power supply inputs. The first is a tightly regulated voltage around -24V or -48V for off-hook voice transmission. The second is a loosely regulated -70 to -100V for ring tone generation. When the switch hook is released the phone puts approximately 200Ω of resistance across the phone terminals. Once voice transmission begins, the SLIC requires a lower voltage input to establish a current loop of approximately 25mA. The loop feeds the 200Ω, protection resistors, and line resistances within the phone.

### ISL6401 Flyback Reference Design

The Typical Application Schematic shows a current mode power supply using the Intersil ISL6401 in a standard flyback topology. The IC requires +5V Bias. The application circuit is intended for wall adapters that power home gateway/router boxes. This circuit input voltage can be 9V to 20V with the selected transformer and external components.

The output voltages are -24V at 120mA and -72V at 120mA. The circuit uses inexpensive transformers to generate both outputs using a single controller. The transformer turns ratio is such that 24V appear across each secondary winding and the primary during the switch off-time. The remaining secondary windings are stacked in series to develop -48V. The -48V section is then stacked on the -24V section to get the -72V. This technique provides good cross regulation, lowers the voltage rating required for the output capacitors, and lowers the RMS current, allowing the use of less expensive output capacitors. Also, the selection of a transformer with multifilar winding lowers the leakage inductance and cost. The -24V output is precisely regulated by feeding back this output to the controller. The -72V output is derived from the third pair of windings. Regulation of this output is obtained by the turn's ratio of the transformer with -24V output, as well as with split feedback.

#### Circuit Element Descriptions

- Transformers T1, MOSFET Q1, Schottky diode D1, D2, and input capacitor C1 and C2 form the power stage of the converter. Power resistor R5 senses the switch current and converts this current into a voltage to be

sensed by the primary side controller feedback comparator.

- Capacitors C9 to C12 filter out high frequency noise on the output bus directly at the output diode.
- R7 and C8 provide secondary side snubbing.
- R6 and C7 filter out the leading edge voltage spikes resulting from the leakage inductance of the transformer.
- C4 sets the switching frequency of the converter.
- C3 is a decoupling capacitor, which should always be a good quality low-ESR / ESL type capacitor, placed as close to the IC pins as possible and returned directly to the IC ground reference.
- The gate drive circuitry can be composed of a small gate drive resistor, necessary for damping any oscillations resulting from the input capacitance of Q1 and any parasitic stray inductance.
- The voltage sense feedback loop is comprised of R4 and R3. Feedback components R1, C6, and C5 provide the necessary gain and pole to stabilize the control loop.

### Component Selection Guidelines

#### Power MOSFET

The MOSFET switch is selected to meet the drain to source voltage stress resulting from the maximum input voltage ( $V_{IN(max)}$ ), the reflected secondary voltages, equal to the output voltage ( $V_{OUT}$ ), plus the output diode voltage drop ( $V_F$ ), and the voltage spike due to the leakage inductance, assumed to be 30% of the input voltage.

$$V_{ds}(\text{stress}) = [ (V_{IN(max)}) + (N)(V_{out} + V_f) ] + (0.3)(V_{IN(max)})$$

The switch must also be able to conduct the repetitive peak primary current as determined by:

$$I_{peak}(\text{primary}) = (V_{in_{min}} - V_{ds})(t_{ON(max)}) / L_p$$

The primary current waveform of a discontinuous mode flyback converter is triangular in shape, therefore, its root mean square(rms) current is calculated by:

$$I_{rms(prim)} = (I_{PEAKprim} / \sqrt{3})(\sqrt{(T_{ONmax}) / T})$$

The chosen device should also have a low  $R_{DS(ON)}$  value, because the conduction losses of the device are proportional to the square of the primary rms current through the device. Selection of a device that has a peak current rating of at least three times the peak current usually insures acceptably low conduction losses.

$$P_{conduction} = (I_{prms}^2) (R_{DS(on)})$$

Switching losses are the result of overlapping drain current and source voltage at turn-off. The drain voltage begins to rise only after the miller capacitance of the device begins to discharge. This discharging time is a function of the external gate resistance,  $R_{gate}$  and the gate-to-drain miller charge  $Q_{gd}$ , as shown in the following equation,

$$T_{miller} = (Q_{gd})(R_{GATE}) / (V_{dd} - V_{th}),$$

where  $V_{th}$  is the turn ON threshold voltage of the gate.

The power loss due to the external capacitance of the MOSFET also contributes to the total switching losses, which can be calculated as shown.

$$P_{switching} = F_{sw} \left[ \frac{C_{oss} \times V_{DS(stress)}^2}{2} + V_{DS(stress)} + I_{peak(primary)} + t_{miller} \right]$$

During turn on there is no overlap of drain voltage and current because there is no current in a discontinuous current mode converter at turn-on. Minimal losses also occur during the off-time of the FET due to the leakage current.

$$P_{off} (time) = (1 - D_{max})(I_{leak})(V_{ds(stress)})$$

### Output and Input Capacitors

Output capacitors are selected based upon their value, equivalent series resistance (ESR), equivalent series inductance and capacitor ripple current rating. The capacitor value controls the peak-to-peak output ripple voltage at the switching frequency. Assuming a linear decay of the capacitor voltage during the off time, during which the capacitor must supply the load current, the minimum value of the output capacitor can be calculated as follows,

$$C_{out} = [(T - T_{ON(max)})(I_{out}) / V_{ripple}],$$

where  $V_{ripple}$  is the acceptable peak-to-peak output voltage ripple. However, there are practical limitations to how low a single stage output filter can reduce the ripple voltage and sometimes an extra LC filter stage is necessary. This second stage filter would also reduce the output high frequency noise. Parasitic resistance and inductance in the output capacitors tend to make the ripple voltage much greater than expected, based upon the above equation. Using capacitors with the lowest possible ESR and ESL helps reduce high frequency ripple. The rms ripple current that the output capacitors experience is not the same as the secondary side rms output current; it is the AC portion of it. The secondary side rms current is in the shape of a clipped sawtooth, or trapezoid, where the output capacitor's current waveform is in the shape of right triangle. Therefore, the typical capacitor ripple current rating the output capacitor must meet is equal to,

$$I_{rms} = (I_{peak}) \sqrt{\left( \frac{T_{reset}}{T} \right) \left( \frac{4 - \frac{(3)(T_{reset})}{T}}{12} \right)}$$

where  $I_{peak}$  (sec) is the peak-secondary current and  $t_{RESET}$  is equal to the off-time of the switch. The same selection criteria is used for the input capacitor, keeping in mind these capacitors must also be rated to handle the maximum input voltage.

### Output Voltage

The output voltage can be set by a feedback resistor divider network. The output is resistively divided and compared to the reference voltage. For negative flyback output applications, the sensed output will be fed to the NFB IN pin. The sensed voltage is inverted, and this positive voltage is fed to the FB- inverting input pin of the error amplifier. The non-inverting input of the error amplifier will be a reference voltage. So, when FB- is higher than REF voltage, the output drivers are turned off. The opposite happens when the resistively divided output voltage falls below the 1.24V reference voltage.

### Output Diode

The output diode in a flyback converter is subject to large peak and rms current stresses. Schottky diodes are recommended, because of their low forward-voltage drop and the virtual absence of minority carrier reverse recovery. The secondary-side Schottky rectifier was selected to meet the working peak-reverse voltage, the peak repetitive forward-current and the average forward-current of the application. The working peak-reverse voltage  $V_{rev}$ , or blocking voltage, is calculated according to the following equation:

$$V_R = [(V_{INmax} + V_{RDSon}) / N] + V_{OUT}$$

The reflected peak primary current constitutes the peak repetitive forward-current through the diode. Because all current to the output capacitors and load must flow through the diode, the average forward diode current is equal to the steady-state load current. Power loss in the Schottky is the sum of the conduction losses and reverse leakage losses. Conduction losses are calculated using the forward voltage drop across the diode and the average forward-current. Reverse leakage losses are dependent upon the reverse leakage-current, the blocking voltage, and the on-time of the FET.

### Determining the Turns Ratio of the Flyback Transformer

The turns ratio of the flyback transformer can be calculated by using the this steady-state volt-second approach:

$$n = [(V_{INmin} - V_{DS})(D_{max})(T)] / [(V_{OUT} + V_F)(0.8 - D_{max})(T)]$$

**Primary Inductance**

The flyback transformer is actually a coupled inductor, acting as an energy storage unit, as well as performing the usual transformer functions. Crucial considerations include primary inductance, working flux density swing, gap length, the winding scheme and wire diameter. The primary inductance,  $L_P$ , for a discontinuous mode flyback converter can be calculated according to the following relationship:

$$L_P = n [(V_{INmin} - V_{DS})(T_{ONmax})]^2 / (2)(T)(V_{OUT})(I_{OUT})$$

Where  $n$  is the assumed efficiency of the converter and  $I_{OUT}$  is the output current. The ferrite core should have high saturation, low residual flux density, and low losses. An EFD15 core material proved to be suitable for this application.

**Current Sense**

The ground referenced sense resistor is selected such that the maximum peak primary current trips the CS pin threshold when this current is 10% higher than its normal operating peak value at the minimum input voltage.

This limits the peak primary current in the event of an output short circuit. This resistor must have a power rating to meet the  $(I_{rms}^2)(R)$  requirement, where  $I_{rms}$  is the root mean square (rms) primary current. Because this resistor defines the maximum peak primary current, the input energy to the transformer is defined and equal to  $(L_P)(I_{PEAK}^2) / 2$ . This defined energy in a fixed frequency discontinuous-mode flyback results in a fixed output power.

The advantage of current-mode control is that the output voltage is held constant despite changes in the input voltage, because the peak-primary current remains constant; the slope of this inductor current and its pulse width are adjusted. Leading edge spikes or noise are caused by the reverse recovery of the rectifier, equivalent capacitive loading on the secondary, and parasitic circuit inductances. A small low pass RC filter is added to the current-sense signal to filter out these spikes, so the comparator does not assume an overload condition is present during switch turn-on. To avoid excessive phase lag on the current-sense signal, the low pass filter corner frequency is selected to be at least a decade above the switching frequency.

**Small Outline Plastic Packages (SOIC)**

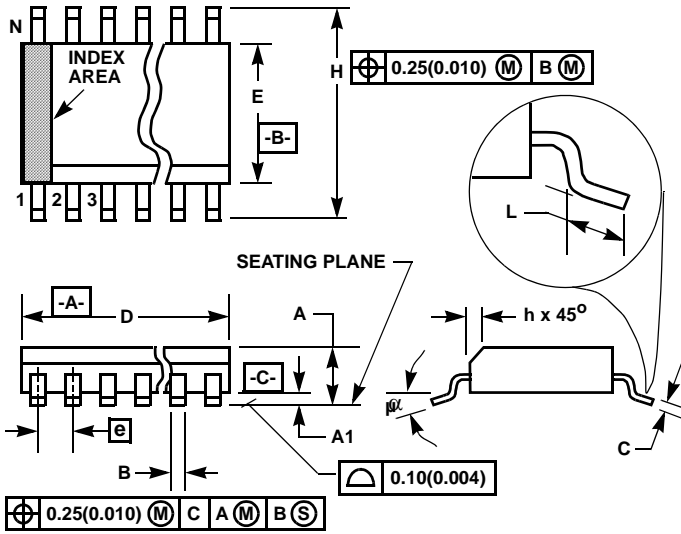

**M14.15 (JEDEC MS-012-AB ISSUE C)**  
**14 LEAD NARROW BODY SMALL OUTLINE PLASTIC PACKAGE**

SYMBOL	INCHES		MILLIMETERS		NOTES
	MIN	MAX	MIN	MAX	
A	0.0532	0.0688	1.35	1.75	-
A1	0.0040	0.0098	0.10	0.25	-
B	0.013	0.020	0.33	0.51	9
C	0.0075	0.0098	0.19	0.25	-
D	0.3367	0.3444	8.55	8.75	3
E	0.1497	0.1574	3.80	4.00	4
e	0.050 BSC		1.27 BSC		-
H	0.2284	0.2440	5.80	6.20	-
h	0.0099	0.0196	0.25	0.50	5
L	0.016	0.050	0.40	1.27	6
N	14		14		7
α	0°	8°	0°	8°	-

**NOTES:**

1. Symbols are defined in the "MO Series Symbol List" in Section 2.2 of Publication Number 95.
2. Dimensioning and tolerancing per ANSI Y14.5M-1982.
3. Dimension "D" does not include mold flash, protrusions or gate burrs. Mold flash, protrusion and gate burrs shall not exceed 0.15mm (0.006 inch) per side.
4. Dimension "E" does not include interlead flash or protrusions. Interlead flash and protrusions shall not exceed 0.25mm (0.010 inch) per side.
5. The chamfer on the body is optional. If it is not present, a visual index feature must be located within the crosshatched area.
6. "L" is the length of terminal for soldering to a substrate.
7. "N" is the number of terminal positions.
8. Terminal numbers are shown for reference only.
9. The lead width "B", as measured 0.36mm (0.014 inch) or greater above the seating plane, shall not exceed a maximum value of 0.61mm (0.024 inch).
10. Controlling dimension: MILLIMETER. Converted inch dimensions are not necessarily exact.

Rev. 0 12/93

**Quad Flat No-Lead Plastic Package (QFN)  
Micro Lead Frame Plastic Package (MLFP)**

**L16.4x4  
16 LEAD QUAD FLAT NO-LEAD PLASTIC PACKAGE  
(COMPLIANT TO JEDEC MO-220-VGGC ISSUE C)**

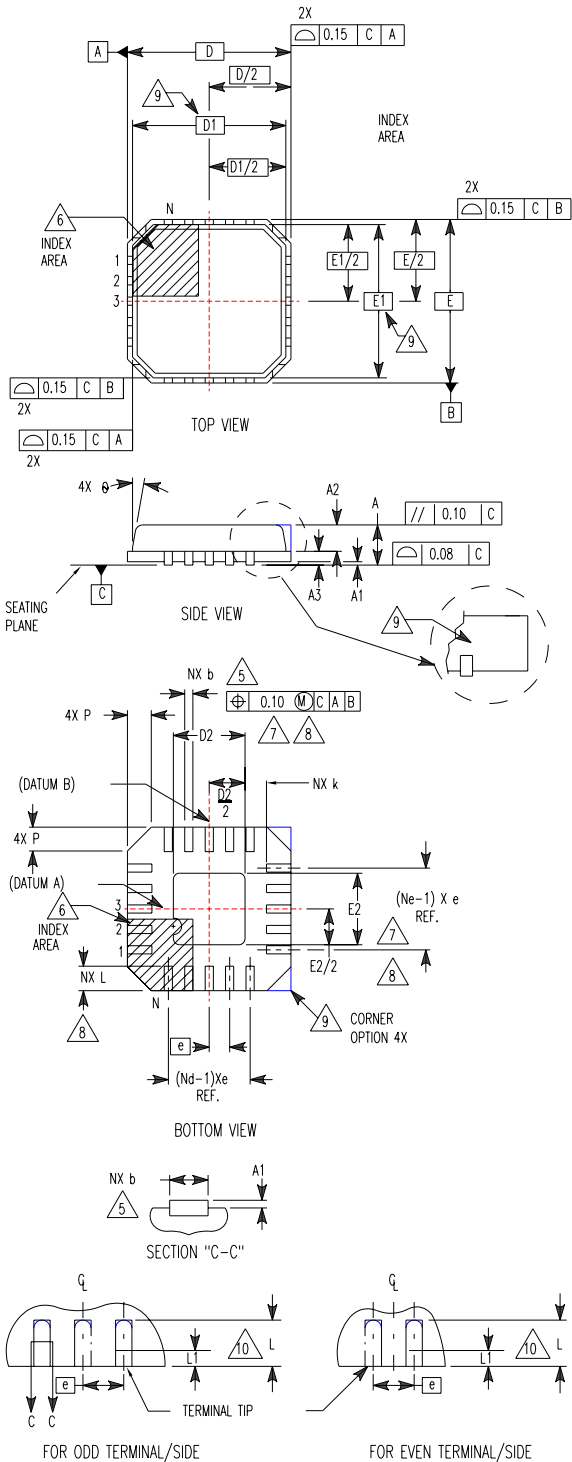

SYMBOL	MILLIMETERS			NOTES
	MIN	NOMINAL	MAX	
A	0.80	0.90	1.00	-
A1	-	-	0.05	-
A2	-	-	1.00	9
A3	0.20 REF			9
b	0.23	0.28	0.38	5, 8
D	4.00 BSC			-
D1	3.75 BSC			9
D2	1.95	2.10	2.25	7, 8
E	4.00 BSC			-
E1	3.75 BSC			9
E2	1.95	2.10	2.25	7, 8
e	0.65 BSC			-
k	0.25	-	-	-
L	0.35	0.60	0.75	8
L1	-	-	0.15	10
N	16			2
Nd	4			3
Ne	4			3
P	-	-	0.60	9
θ	-	-	12	9

Rev. 4 10/02

**NOTES:**

1. Dimensioning and tolerancing conform to ASME Y14.5-1994.
2. N is the number of terminals.
3. Nd and Ne refer to the number of terminals on each D and E.
4. All dimensions are in millimeters. Angles are in degrees.
5. Dimension b applies to the metallized terminal and is measured between 0.15mm and 0.30mm from the terminal tip.
6. The configuration of the pin #1 identifier is optional, but must be located within the zone indicated. The pin #1 identifier may be either a mold or mark feature.
7. Dimensions D2 and E2 are for the exposed pads which provide improved electrical and thermal performance.
8. Nominal dimensions are provided to assist with PCB Land Pattern Design efforts, see Intersil Technical Brief TB389.
9. Features and dimensions A2, A3, D1, E1, P & θ are present when Anvil singulation method is used and not present for saw singulation.
10. Depending on the method of lead termination at the edge of the package, a maximum 0.15mm pull back (L1) maybe present. L minus L1 to be equal to or greater than 0.3mm.

All Intersil U.S. products are manufactured, assembled and tested utilizing ISO9000 quality systems.  
Intersil Corporation's quality certifications can be viewed at [www.intersil.com/design/quality](http://www.intersil.com/design/quality)

*Intersil products are sold by description only. Intersil Corporation reserves the right to make changes in circuit design, software and/or specifications at any time without notice. Accordingly, the reader is cautioned to verify that data sheets are current before placing orders. Information furnished by Intersil is believed to be accurate and reliable. However, no responsibility is assumed by Intersil or its subsidiaries for its use; nor for any infringements of patents or other rights of third parties which may result from its use. No license is granted by implication or otherwise under any patent or patent rights of Intersil or its subsidiaries.*

For information regarding Intersil Corporation and its products, see [www.intersil.com](http://www.intersil.com)

This datasheet has been downloaded from:

[www.DatasheetCatalog.com](http://www.DatasheetCatalog.com)

Datasheets for electronic components.



LittleDiode supplies new, hard to find or obsolete electronic components and semiconductors all over the world.

With over two million different components listed you are sure to find the part you need.

Feel free to visit us today at our online store:

[LittleDiode.com](http://LittleDiode.com)

Looking forward to providing you with the best possible service.