

## Multiple Linear Power Controller with ACPI Control Interface

The ISL6505 complements other power building blocks (voltage regulators) in ACPI-compliant designs for microprocessor and computer applications. The IC integrates three linear controllers/regulators, switching, monitoring and control functions into a 20-pin wide-body SOIC or 20-pin QFN (also known as MLF) 5x5 package. The ISL6505's operating mode (active or sleep outputs) is selectable through two digital control pins,  $\overline{S3}$  and  $\overline{S5}$ .

One linear controller generates the 3.3V<sub>DUAL</sub>/3.3V<sub>SB</sub> voltage plane from the ATX supply's 5V<sub>SB</sub> output, powering the south bridge and the PCI slots through an external NPN pass transistor during sleep states (S3, S4/S5). In active state (during S0 and S1/S2), the 3.3V<sub>DUAL</sub>/3.3V<sub>SB</sub> linear regulator uses an external N-channel pass MOSFET to connect the outputs directly to the 3.3V input supplied by an ATX power supply, for minimal losses. The 3.3V<sub>DUAL</sub>/3.3V<sub>SB</sub> output is active for as long as the ATX 5V<sub>SB</sub> voltage is applied to the chip.

A controller powers up the 5V<sub>DUAL</sub> plane by switching in the ATX 5V output through an NMOS transistor in active states, or by switching in the ATX 5V<sub>SB</sub> through a PMOS (or PNP) transistor in S3 sleep state. In S4/S5 sleep states, the ISL6505 5V<sub>DUAL</sub> output is either shut down or stays on, based on the state of the EN5 pin.

An internal linear regulator supplies the 1.2V for the voltage identification circuitry (VID) only during active states (S0 and S1/S2), and uses the 3V3 pin as input source for its internal pass element.

A linear controller generates V<sub>OUT1</sub> from the 3.3V<sub>DUAL</sub>/3.3V<sub>SB</sub> voltage plane, using an external NFET. The voltage is user-programmable to values between 1.2V and 1.5V, using an external resistor divider. The mode is user-selectable with the LAN pin; a logic high (or open) selects the 10/100 LAN mode, where V<sub>OUT1</sub> is always on (S0-S5); a logic low selects the Gigabit Ethernet mode, where V<sub>OUT1</sub> is only on during active modes (S0-S2).

## Ordering Information

PART NUMBER	TEMP. RANGE (°C)	PACKAGE	PKG. DWG. #
ISL6505CB	0 to 70	20 Ld Wide SOIC	M20.3
ISL6505CR	0 to 70	20 Ld 5x5 QFN	L20.5x5
ISL6505EVAL1	Evaluation Board (SOIC)		
ISL6505AEVAL2	Evaluation Board (QFN)		

## Features

- Provides four ACPI-Controlled Voltages
  - 5V<sub>DUAL</sub> USB/Keyboard/Mouse
  - 3.3V<sub>DUAL</sub>/3.3V<sub>SB</sub> PCI/Auxiliary/LAN
  - 1.2V<sub>VID</sub> Processor VID Circuitry
  - V<sub>OUT1</sub> (1.2V - 1.5V programmable) LAN/Ethernet
- Excellent Output Voltage Regulation
  - All Outputs: ±2.0% over temperature (as applicable)
- Small Size; Very Low External Component Count
- Undervoltage Monitoring of All Outputs with Centralized FAULT Reporting and Temperature Shutdown
- QFN Package:
  - Compliant to JEDEC PUB95 MO-220
  - QFN - Quad Flat No Leads - Package Outline
  - Near Chip Scale Package footprint, which improves PCB efficiency and has a thinner profile

## Applications

- ACPI-Compliant Power Regulation for Motherboards

## Pinouts

ISL6505 (20-LEAD-WIDE SOIC) TOP VIEW

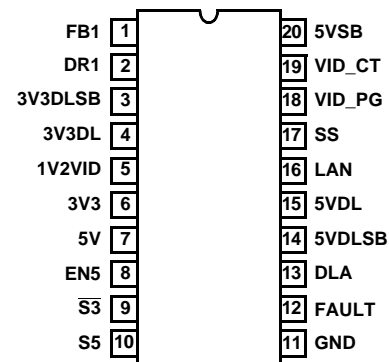

ISL6505 (5 x 5 QFN) TOP VIEW

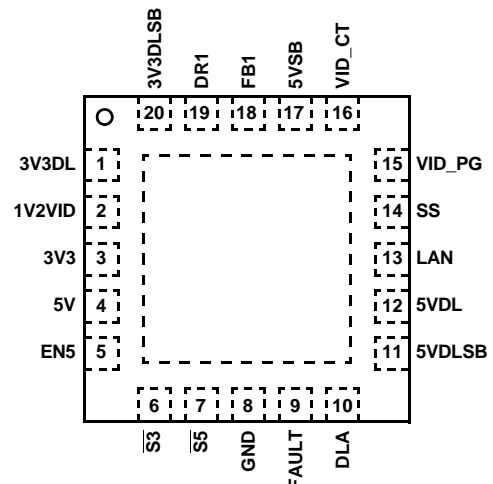

NOTE: The QFN bottom pad is electrically connected to the IC substrate, at GND potential. It can be left unconnected, or connected to GND; do NOT connect to another potential.

Block Diagram

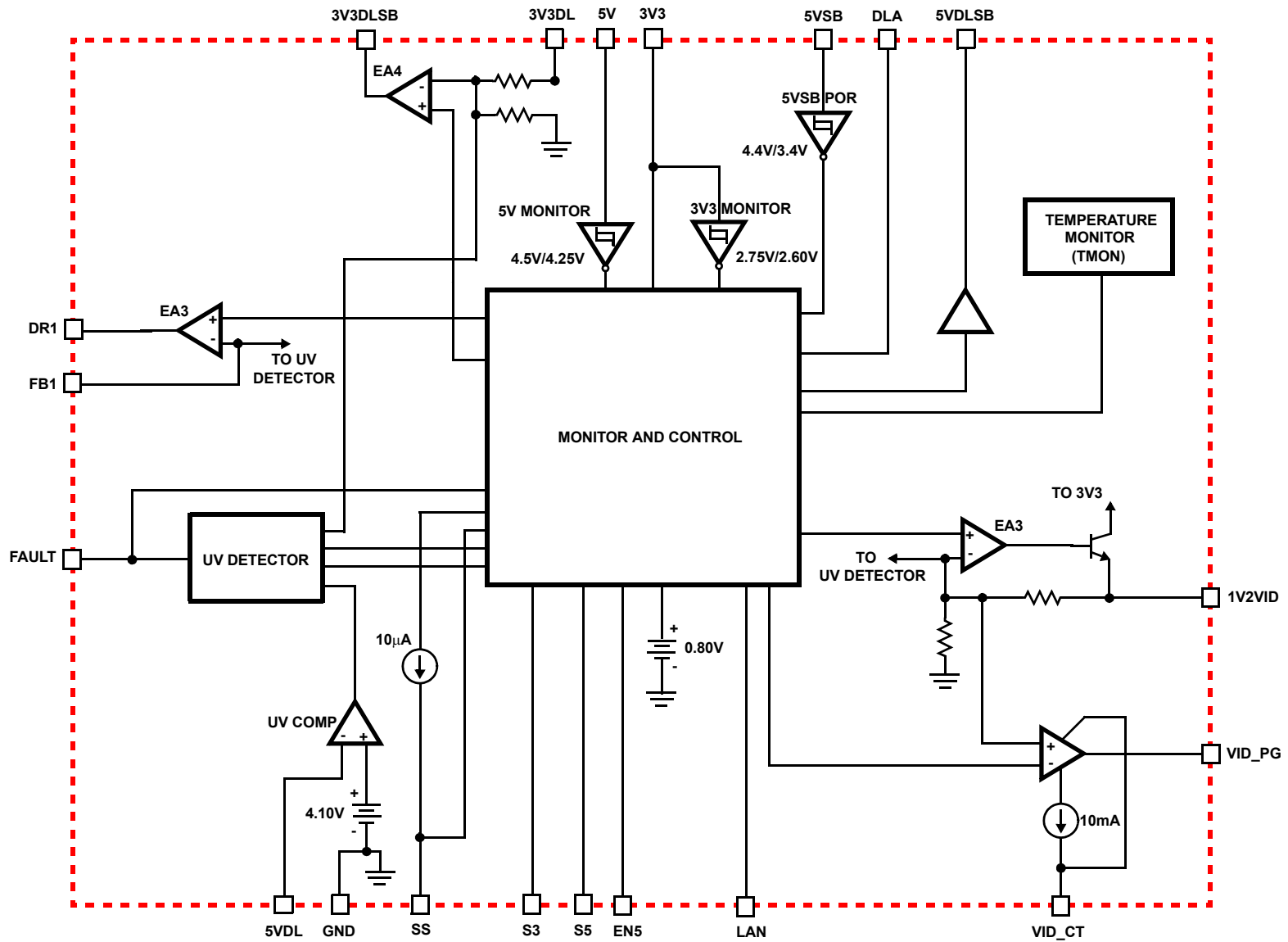

FIGURE 1.

**Simplified Power System Diagram**

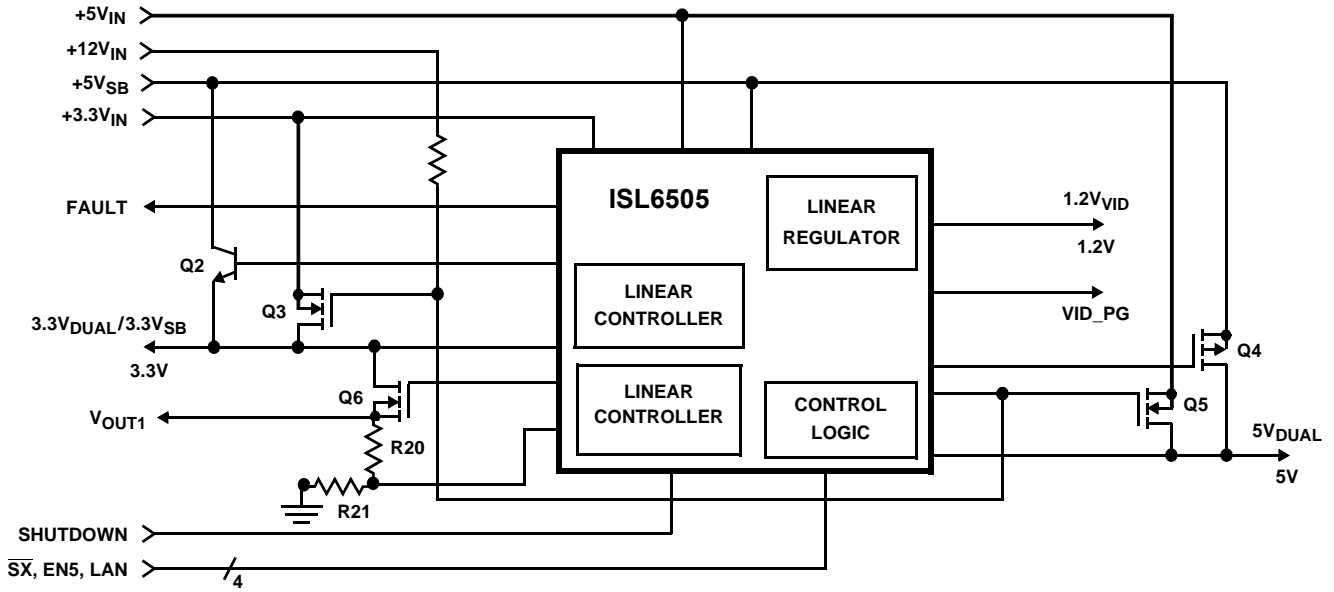

FIGURE 2.

**Typical Application**

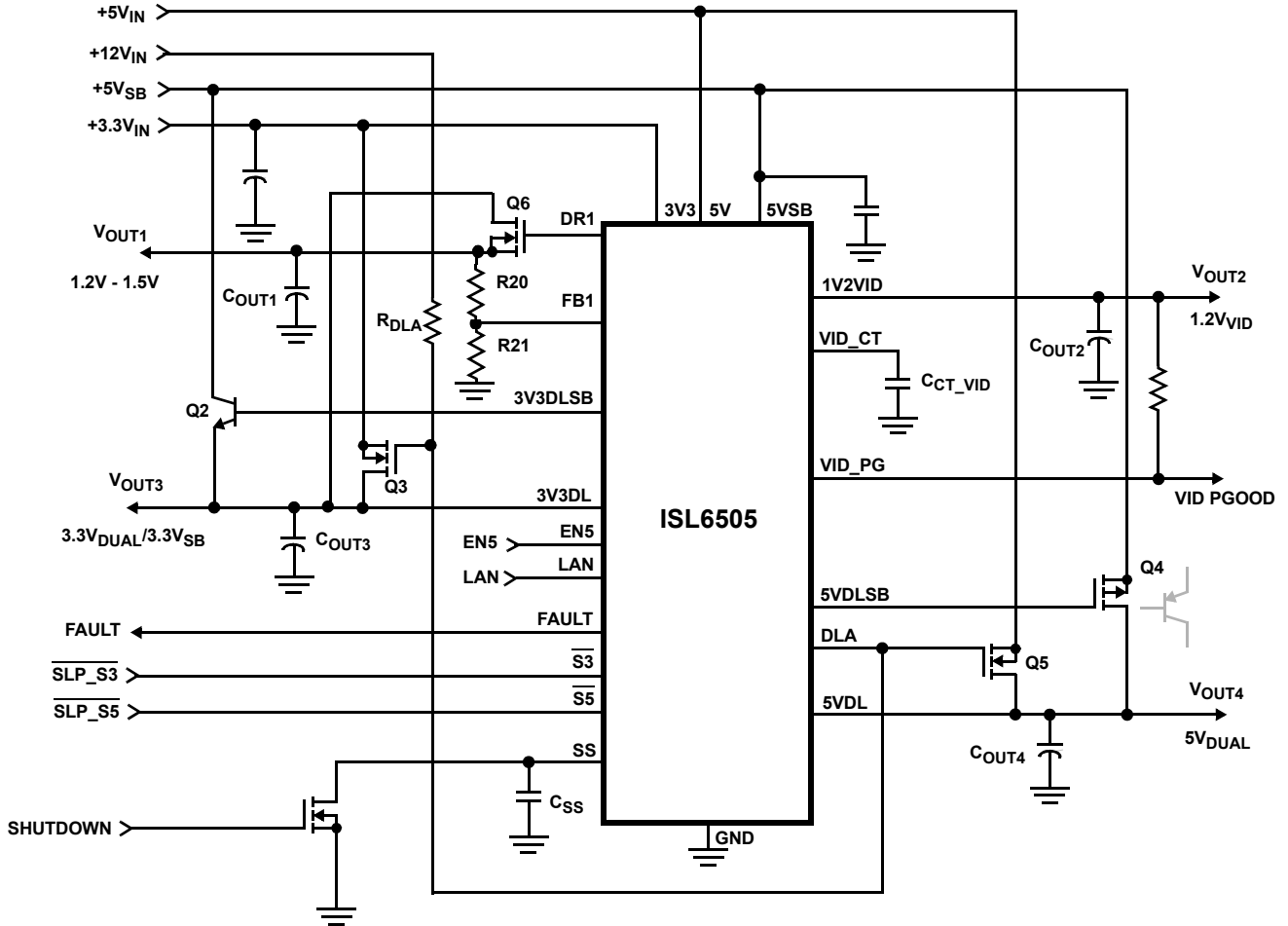

FIGURE 3.

**Absolute Maximum Ratings**

Supply Voltage, $V_{5VSB}$ .....	+7.0V
DLA .....	GND - 0.3V to +14.5V
All Other Pins .....	+ 7.0V
ESD Classification (Human Body Model) .....	.2kV

**Recommended Operating Conditions**

Supply Voltage, $V_{5VSB}$ .....	+5V $\pm$ 5%
Lowest 5VSB Supply Voltage Guaranteeing Parameters .....	+4.5V
Digital Inputs, $V_{SX}$ .....	.0 to +5.5V
Ambient Temperature Range .....	0°C to 70°C
Junction Temperature Range .....	0°C to 125°C

**Thermal Information**

Thermal Resistance (Typical)	$\theta_{JA}$ (°C/W)	$\theta_{JC}$ (°C/W)
SOIC Package (Note 1) .....	65	N/A
QFN Package (Notes 2, 3) .....	35	5
Maximum Junction Temperature (Plastic Package) .....	150°C	
Maximum Storage Temperature Range .....	-65°C to 150°C	
Maximum Lead Temperature (Soldering 10s) .....	300°C (SOIC - Lead Tips Only)	

*CAUTION: Stresses above those listed in "Absolute Maximum Ratings" may cause permanent damage to the device. This is a stress only rating and operation of the device at these or any other conditions above those indicated in the operational sections of this specification is not implied.*

**NOTES:**

- $\theta_{JA}$  is measured with the component mounted on a high effective thermal conductivity test board in free air. See Tech Brief TB379 for details.
- $\theta_{JA}$  is measured in free air with the component mounted on a high effective thermal conductivity test board with "direct attach" features. See Tech Brief TB379.
- For  $\theta_{JC}$ , the "case temp" location is the center of the exposed metal pad on the package underside.

**Electrical Specifications** Recommended Operating Conditions, Unless Otherwise Noted Refer to Figures 1, 2 and 3

PARAMETER	SYMBOL	TEST CONDITIONS	MIN	TYP	MAX	UNITS
<b>VCC SUPPLY CURRENT</b>						
Nominal Supply Current	$I_{5VSB}$		-	6	-	mA
Shutdown Supply Current	$I_{5VSB(OFF)}$	$V_{SS} = 0.8V$	-	4	-	mA
<b>POWER-ON RESET, SOFT-START, AND VOLTAGE MONITORS</b>						
5VSB Rising POR Threshold			4.1	4.3	4.5	V
5VSB Falling POR Threshold			3.2	3.4	3.5	V
5VSB POR Hysteresis			-	0.9	-	V
3V3 Rising Threshold			2.85	2.93	3.00	V
3V3 Falling Threshold			2.70	2.78	2.85	V
3V3 Hysteresis			-	150	-	mV
5V Rising Threshold			4.3	4.4	4.5	V
5V Falling Threshold			4.05	4.15	4.25	V
5V Hysteresis			-	250	-	mV
VID_PG Rising Threshold			-	1.04	-	V
VID_PG Hysteresis			-	50	-	mV
VID_CT Charging Current	$I_{VID\_CT}$	$V_{VID\_CT} = 0V$	-	10	-	$\mu A$
Soft-Start Current	$I_{SS}$		-	10	-	$\mu A$
Soft-Start Shutdown Voltage Threshold	$V_{SD}$		-	-	0.8	V
<b>LINEAR REGULATOR (<math>V_{OUT1}</math>; DR1 and FB1 pins)</b>						
$V_{OUT1}$ Regulation		$V_{OUT1} = 1.2V$ to $1.5V$	-	-	2.0	%
$V_{OUT1}$ Nominal Voltage Level	$V_{OUT1}$	Based on external resistors	-	1.5	-	V
$V_{OUT1}$ Undervoltage Rising Threshold		FB1 pin	-	1.2	-	V
$V_{OUT1}$ Undervoltage Hysteresis		FB1 pin	-	50	-	mV
DR1 Output Drive Current	$I_{DR1}$	$V_{3V3DL} = 3.3V$	-	10	-	mA

**Electrical Specifications** Recommended Operating Conditions, Unless Otherwise Noted Refer to Figures 1, 2 and 3 **(Continued)**

PARAMETER	SYMBOL	TEST CONDITIONS	MIN	TYP	MAX	UNITS
<b>1.2V<sub>VID</sub> LINEAR REGULATOR (V<sub>OUT2</sub>)</b>						
1V2VID Regulation			-	-	2.0	%
1V2VID Nominal Voltage Level	V <sub>1V2VID</sub>		-	1.2	-	V
1V2VID Undervoltage Rising Threshold			-	0.92	-	V
1V2VID Undervoltage Hysteresis			-	100	-	mV
1V2VID Output Current	I <sub>1V2VID</sub>	V <sub>3V3</sub> = 3.3V	-	-	180	mA
<b>3.3V<sub>DUAL</sub>/3.3V<sub>SB</sub> LINEAR REGULATOR (V<sub>OUT3</sub>)</b>						
3V3DL Sleep State Regulation			-	-	2.0	%
3V3DL Nominal Voltage Level	V <sub>3V3DL</sub>		-	3.3	-	V
3V3DL Undervoltage Rising Threshold			-	2.62	-	V
3V3DL Undervoltage Hysteresis			-	150	-	mV
3V3DLSB Output Drive Current	I <sub>3V3DLSB</sub>	V <sub>5VSB</sub> = 5V	30	50	-	mA
<b>5V<sub>DUAL</sub> SWITCH CONTROLLER (V<sub>OUT4</sub>)</b>						
5VDL Undervoltage Rising Threshold			-	4.10	-	V
5VDL Undervoltage Hysteresis			-	120	-	mV
5VDLSB Output Drive Current	I <sub>5VDLSB</sub>	V <sub>5VDLSB</sub> = 4V, V <sub>5VSB</sub> = 5V	-20	-	-40	mA
<b>TIMING INTERVALS</b>						
Active State Assessment Past Input UV Thresholds (Note 4)			42	53	64	ms
Active-to-Sleep Control Input Delay			-	200	-	μs
Falling UV Threshold Timeout (All Monitors)			-	10	-	μs
<b>CONTROL I/O (<math>\overline{S3}</math>, <math>\overline{S5}</math>, EN5, LAN, FAULT)</b>						
High Level Input Threshold		$\overline{S3}$ , $\overline{S5}$ , EN5, LAN	-	-	2.2	V
Low Level Input Threshold		$\overline{S3}$ , $\overline{S5}$ , EN5, LAN	0.8	-	-	V
Internal Pull-up Current to 5VSB		$\overline{S3}$ , $\overline{S5}$ to GND	-	50	-	μA
Internal Pull-up Current to 5VSB		EN5, LAN to GND	-	10	-	μA
Input Leakage Current to 5VSB		EN5, LAN to 5VSB	-	-	10	μA
FAULT Current I <sub>oh</sub> (to 5VSB)		FAULT = 4.6V, 5VSB = 5V	-	-7.5	-	mA
FAULT Current I <sub>ol</sub> (to GND)		FAULT = 0.4V, 5VSB = 5V	-	0.75	-	mA
<b>TEMPERATURE MONITOR</b>						
Fault-Level Threshold (Note 5)			125	-	-	°C
Shutdown-Level Threshold (Note 5)			-	155	-	°C

NOTES:

4. Guaranteed by Correlation.
5. Guaranteed by Design.

## Functional Pin Description (Pin numbers for SOIC and QFN)

### 3V3 (Pin 6 SOIC; Pin 3 QFN)

Connect this pin to the ATX 3.3V output. This pin provides the output current for the 1V2VID pin, and is monitored for power quality.

### 5V (Pin 7 SOIC; Pin 4 QFN)

Connect this pin to the ATX 5V output. This pin is only monitored for power quality.

### 5VSB (Pin 20 SOIC; Pin 17 QFN)

Provide a very well de-coupled 5V bias supply for the IC to this pin by connecting it to the ATX 5V<sub>SB</sub> output. This pin provides all the chip's bias as well as the base current for Q2 (see typical application diagram). The voltage at this pin is monitored for power-on reset (POR) purposes.

### GND (Pin 11 SOIC; Pin 8 QFN)

Signal ground for the IC. All voltage levels are measured with respect to this pin.

### $\overline{S3}$ and $\overline{S5}$ (Pins 9, 10 SOIC; Pins 6, 7 QFN)

These pins switch the IC's operating state from active (S0, S1/S2) to S3 and S4/S5 sleep states. These are digital inputs featuring internal 50 $\mu$ A (typical) current source pull-ups to 5VSB. Internal circuitry de-glitches these pins for disturbances lasting as long as 2 $\mu$ s (typically). Additional circuitry blocks illegal state transitions (such as S4/S5 to S3), but **does allow** S3 to S4/S5. Connect  $\overline{S3}$  and  $\overline{S5}$  respectively to the computer system's SLP\_S3 and SLP\_S5 signals.

### EN5 (Pin 8 SOIC; Pin 5 QFN)

This digital input selects whether the 5VDL output stays up or shuts down during the S5 Sleep Mode. It has a 10 $\mu$ A typical pull-up current source. A logic high (5V) or open will keep the 5VDL on during S5; a logic low (GND) will shut it off during S5. NOTE: This pin should be tied low or high (or open) on the board; it was not designed to be changed during normal operation.

### LAN (Pin 16 SOIC; Pin 13 QFN)

This digital input selects between two modes for the V<sub>OUT1</sub> regulator. It has a 10 $\mu$ A pull-up current source. A logic high (5V) or open selects the 10/100 LAN mode, where V<sub>OUT1</sub> stays on all of the time (active and sleep modes). A logic low (GND) selects the Gigabit Ethernet mode, where V<sub>OUT1</sub> is only on during active (S0, S1) modes. Note that this selection is independent of the voltage selection of V<sub>OUT1</sub> (which is determined by the external resistor divider). NOTE: This pin should be tied low or high (or open) on the board; it was not designed to be changed during normal operation.

### FAULT (Pin 12 SOIC; Pin 9 QFN)

This digital output pin is used to report the fault condition by being pulled to 5VSB (pulled to GND if no fault). It is a CMOS digital output; an external pull-down resistor is **NOT** required. In case of an undervoltage on any of the controlled outputs, on any of the monitored ATX voltages (3V3 or 5V; not 12V), or in case of an overtemperature event, this pin is used to report the fault condition.

### SS (Pin 17 SOIC; Pin 14 QFN)

Connect this pin to a small ceramic capacitor (no less than 5nF; 0.1 $\mu$ F recommended). The internal soft-start (SS) current source along with the external capacitor creates a voltage ramp used to control the ramp-up of the output voltages. Pulling this pin low (to GND) with an open-drain device shuts down all the outputs as well as forces the FAULT pin low. The C<sub>SS</sub> capacitor is also used to provide a controlled voltage slew rate during active-to-sleep transitions on the 3.3V<sub>DUAL</sub>/3.3V<sub>SB</sub> output.

### 3V3DL (Pin 4 SOIC; Pin 1 QFN)

Connect this pin to the 3.3V dual/stand-by output (V<sub>OUT3</sub>). In sleep states, the voltage at this pin is regulated to 3.3V; in active states, ATX 3.3V output is delivered to this node through a fully-on NFET transistor. During all operating states, this pin is monitored for undervoltage events. This pin provides all the output current delivered by V<sub>OUT1</sub>.

### 3V3DLSB (Pin 3 SOIC; Pin 20 QFN)

Connect this pin to the base of a suitable NPN transistor. In sleep state, this transistor is used to regulate the voltage at the 3V3DL pin to 3.3V.

### DLA (Pin 13 SOIC; Pin 10 QFN)

This pin is an open-collector output. Connect a 1k $\Omega$  resistor from this pin to the ATX 12V output. This resistor is used to pull the gates of suitable NFETs to 12V, which in active state, switch in the ATX 3.3V and 5V outputs into the 3.3V<sub>DUAL</sub>/3.3V<sub>SB</sub> and 5V<sub>DUAL</sub> outputs, respectively.

### 5VDL (Pin 15 SOIC; Pin 12 QFN)

Connect this pin to the 5V<sub>DUAL</sub> output (V<sub>OUT4</sub>). In either operating state (when on), the voltage at this pin is provided through a fully-on MOSFET transistor. This pin is also monitored for undervoltage events.

### 5VDLSB (Pin 14 SOIC; Pin 11 QFN)

Connect this pin to the gate of a suitable PFET or bipolar PNP. This transistor is switched on, connecting the ATX 5V<sub>SB</sub> output to the 5V<sub>DUAL</sub> regulator output during S3, and if EN5 is open or high, during S5. If EN5 is low (GND), the transistor is switched off in S5.

### DR1 (Pin 2 SOIC; Pin 19 QFN)

This output pin drives the gate of an external NFET transistor to create V<sub>OUT1</sub>, which draws its output current from the 3V3DL pin.

**FB1 (Pin 1 SOIC; Pin 18 QFN)**

This analog input pin looks at the  $V_{OUT1}$  external resistor divider, and compares it to the internal reference (0.8V nominal), in order to regulate the voltage on  $V_{OUT1}$ . This pin is also monitored for undervoltage events.

**1V2VID (Pin 5 SOIC; Pin 2 QFN)**

This pin is the output of the internal 1.2V voltage identification (VID) regulator ( $V_{OUT2}$ ). This internal regulator operates only in active states (S0, S1/S2) and is shut off during any sleep state. This regulator draws its output current from the 3V3 pin. This pin is monitored for undervoltage events.

**VID\_PG (Pin 18 SOIC; Pin 15 QFN)**

This pin is the open collector output of the 1V2VID power good comparator. Connect a 10k $\Omega$  pull-up resistor from this pin to the 1V2VID output. As long as the 1V2VID output is below its PG threshold (typically 90% of final value), this pin is pulled low. Once the PG threshold is reached, the VID\_CT pin starts charging its capacitor (setting the delay); when it reaches its trip point, then the VID-PG pin releases, and goes high (through the external pull-up resistor).

**VID\_CT (Pin 19 SOIC; Pin 16 QFN)**

Connect a small capacitor from this pin to ground. The capacitor is used to delay the VID\_PG reporting the 1V2VID has reached power good limits.

**Description****Operation**

The ISL6505 controls 4 output voltages (Refer to Figures 1, 2, and 3). It is designed for microprocessor computer applications with 3.3V, 5V, 5V<sub>SB</sub>, and 12V bias input from an ATX power supply. The IC is composed of three linear controllers/regulators supplying the computer system's  $V_{OUT1}$  (1.2V - 1.5V programmable), 3.3V<sub>SB</sub> and PCI slots' 3.3V<sub>AUX</sub> power ( $V_{OUT3}$ ), the 1.2V VID circuitry power ( $V_{OUT2}$ ), a dual switch controller supplying the 5V<sub>DUAL</sub> voltage ( $V_{OUT4}$ ), as well as all the control and monitoring functions necessary for complete ACPI implementation.

**Initialization and POR**

The ISL6505 automatically initializes upon receipt of input power. The Power-On Reset (POR) function continually monitors the 5V<sub>SB</sub> input supply voltage, initiating 3.3V<sub>DUAL</sub>/3.3V<sub>SB</sub> and 1.5V<sub>SB</sub> soft-start operation shortly after exceeding POR threshold.

Note that while the 5V<sub>SB</sub> pin has the main POR, both the 3V3 and 5V pins (12V is not monitored) must rise above their own POR levels (typically 90%) in order to transition into the S0/S1 active state. If during normal operation either one drops below their falling trip points, the IC will go to the S5 sleep mode. When both are back above their rising thresholds, the IC will again soft-start into active state.

**Output Operational Truth Tables**

Table 1 describes the truth combinations pertaining to the 3.3V<sub>DUAL</sub>/SB and 5V<sub>DUAL</sub> dual outputs. The last two lines highlight the difference between EN5 connected high or low.

Table 2 describes the truth combinations pertaining to the  $V_{OUT1}$  (typically between 1.2V and 1.5V) and 1V2VID outputs. The last two sets of lines highlight the difference between the two LAN pin modes (5V/open is the 10/100 LAN mode; GND is the Gigabit Ethernet mode).

The internal circuitry does not allow the transition from an S4/S5 (suspend to disk/soft off) state to an S3 (suspend to RAM) state; however, it **does allow** the transition from S3 to S4/S5. The only 'legal' transitions are from an active state (S0, S1) to a sleep state (S3, S5) and vice versa.

**TABLE 1. 5V<sub>DUAL</sub> OUTPUT ( $V_{OUT4}$ ) AND 3.3V<sub>DUAL</sub>/SB ( $V_{OUT3}$ ) TRUTH TABLE**

$\overline{S5}$	$\overline{S3}$	3.3V <sub>DUAL</sub> /SB	5V <sub>DUAL</sub>	COMMENTS
1	1	3.3V	5V	S0/S1/S2 States (Active)
1	0	3.3V	5V	S3
0	1	Note		Maintains Previous State
0	0	3.3V	0V	S4/S5 (EN5 = GND)
0	0	3.3V	5V	S4/S5 (EN5 = open/5V)

NOTE: Combination Not Allowed.

**TABLE 2.  $V_{OUT1}$  AND 1V2VID ( $V_{OUT2}$ ) TRUTH TABLE**

$\overline{S5}$	$\overline{S3}$	$V_{OUT1}$	1V2VID	COMMENTS
1	1	1.5V	1.2V	S0/S1/S2 States (Active)
1	0	0V	0V	S3 (LAN = GND)
1	0	1.5V	0V	S3 (LAN = open/5V)
0	1	Note		Maintains Previous State
0	0	0V	0V	S4/S5 (LAN = GND)
0	0	1.5V	0V	S4/S5 (LAN = open/5V)

NOTE: Combination Not Allowed.

**Functional Timing Diagrams**

Figures 4 (EN5 = low), 5 (EN5 = high), and 6 are timing diagrams, detailing the power up/down sequences of all the outputs in response to the status of the sleep-state pins ( $\overline{S3}$ ,  $\overline{S5}$ ), as well as the status of the input ATX supply. Not shown in these diagrams is the deglitching feature used to protect against false sleep state tripping. Both  $\overline{S3}$  and  $\overline{S5}$  pins are protected against noise by a 2 $\mu$ s filter (typically 1–4 $\mu$ s). This feature is useful in noisy computer environments if the control signals have to travel over significant distances. Additionally, the  $\overline{S3}$  pin features a 200 $\mu$ s delay in transitioning to sleep states. Once the  $\overline{S3}$  pin goes low, an internal timer is activated. At the end of the 200 $\mu$ s interval, if the  $\overline{S5}$  pin is low, the ISL6505 switches into S5 sleep state; if the  $\overline{S5}$  pin is high, the ISL6505 goes into S3 sleep state.

The shaded column in Figures 4 and 5 highlights the difference on the 5VDLSB and 5VDL pins for the two EN5 states.

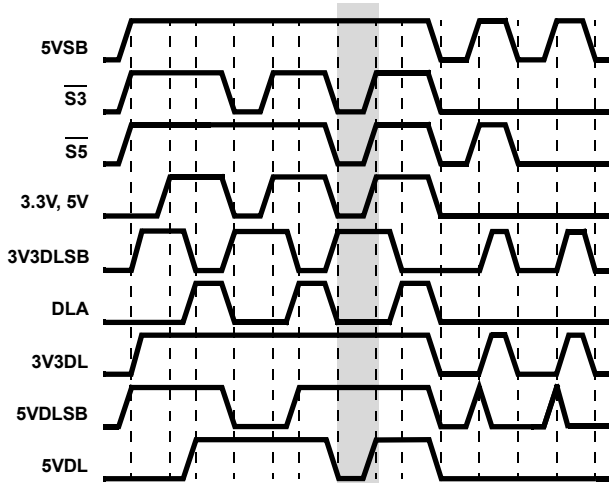

FIGURE 4. 5V<sub>DUAL</sub> AND 3.3V<sub>DUAL</sub>/3.3V<sub>SB</sub> TIMING DIAGRAM; EN5 = GND

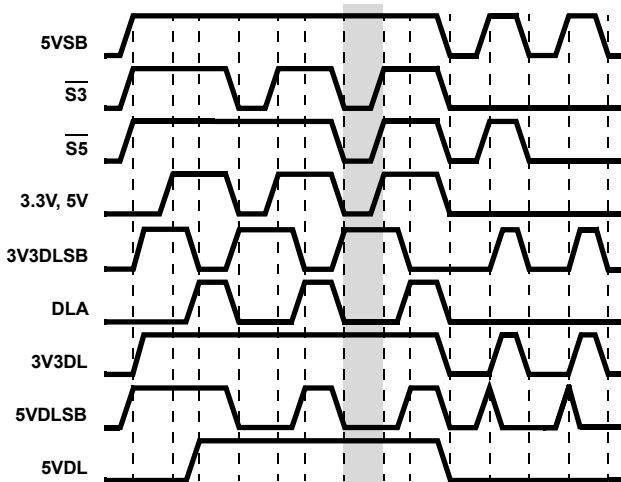

FIGURE 5. 5V<sub>DUAL</sub> AND 3.3V<sub>DUAL</sub>/3.3V<sub>SB</sub> TIMING DIAGRAM; EN5 = 5V/open

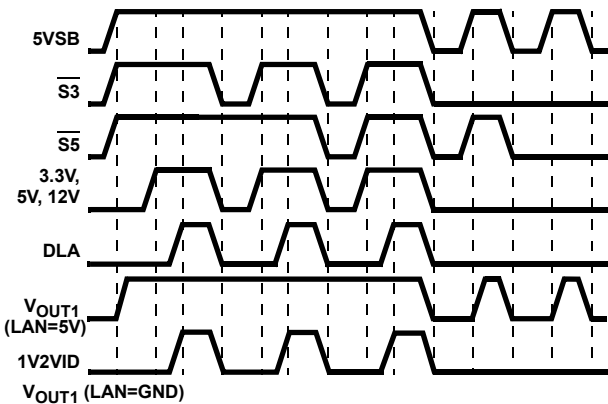

FIGURE 6. V<sub>OUT1</sub> AND 1.2V<sub>VID</sub> TIMING DIAGRAM (NOTE THE DEPENDENCE OF V<sub>OUT1</sub> ON THE LOGIC STATE OF LAN PIN)

**Soft-Start into Sleep States (S3, S4/S5)**

The 5V<sub>SB</sub> POR function initiates the soft-start sequence. An internal 10μA current source charges an external capacitor. The error amplifiers' reference inputs are clamped to a level proportional to the SS (soft-start) pin voltage. As the SS pin voltage slews from about 1.4V to 3.0V, the input clamp allows a rapid and controlled output voltage rise.

Figures 7 (EN5 = low) and 8 (EN5 = high) show the soft-start sequence for the typical application start-up into a sleep state. At time T0 5V<sub>SB</sub> (bias) is applied to the circuit. At time T1, the 5V<sub>SB</sub> surpasses POR level. An internal fast charge circuit quickly raises the SS capacitor voltage to approximately 1V, then the 10μA current source continues the charging.

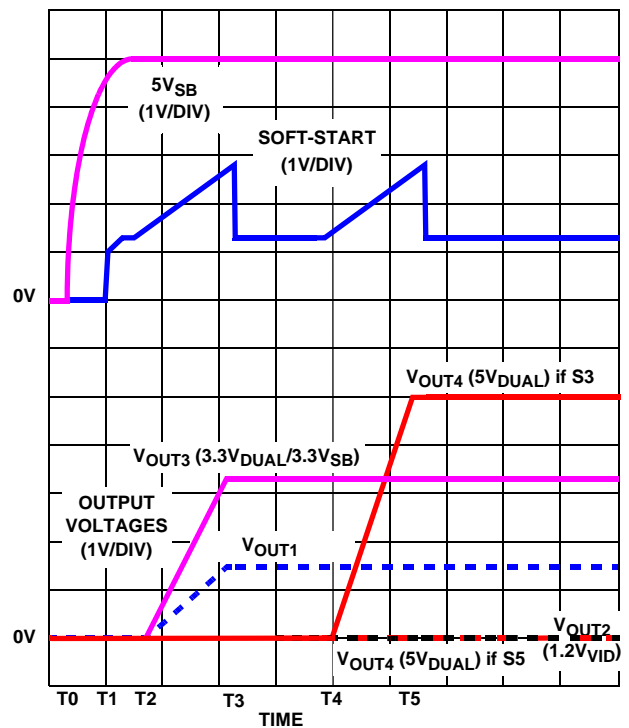

FIGURE 7. SOFT-START INTERVAL IN A SLEEP STATE; EN5 = GND; LAN = 5V/OPEN

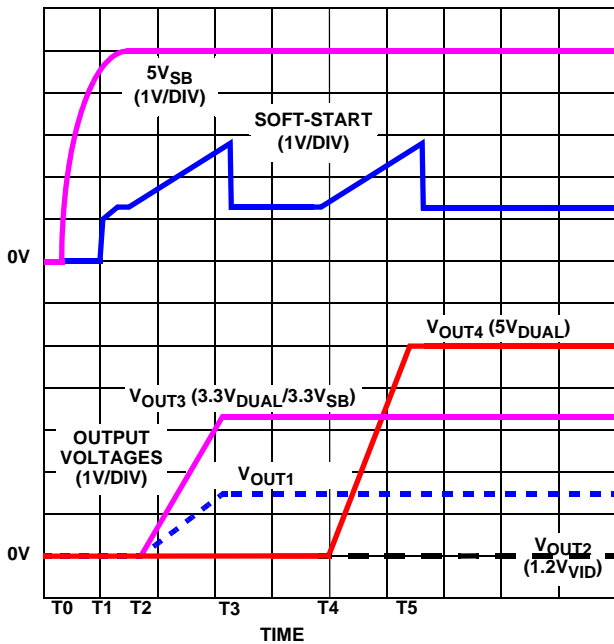

FIGURE 8. SOFT-START INTERVAL IN A SLEEP STATE;  
EN5 = 5V/OPEN; LAN = 5V/OPEN

The soft-start capacitor voltage reaches approximately 1.4V at time T2, at which point the 3.3V<sub>DUAL</sub>/3.3V<sub>SB</sub> and V<sub>OUT1</sub> error amplifiers' reference inputs start their transition, resulting in the output voltages ramping up proportionally. The ramp-up continues until time T3 when the two voltages reach the set value. As the soft-start capacitor voltage reaches approximately 3.0V, the undervoltage monitoring circuit of this output is activated and the soft-start capacitor is quickly discharged to approximately 1.4V. Following the 3ms (typical) time-out between T3 and T4, the soft-start capacitor commences a second ramp-up designed to smoothly bring up the remainder of the voltages required by the system. At time T5, voltages are within regulation limits, and as the SS voltage reaches 3.0V, all the remaining UV monitors are activated and the SS capacitor is quickly discharged to 1.4V, where it remains until the next transition. As the 1.2V<sub>VID</sub> output is only on while in an active state, it does not come up, but rather waits until the main ATX outputs come up within regulation limits.

Note that in Figures 7 and 8, LAN = 5V/open. If the LAN pin is connected to GND instead, then the V<sub>OUT1</sub> output does not turn on at all in either sleep mode (S3 or S4/S5).

### Soft-Start into Active States (S0, S1)

If both  $\overline{S3}$  and  $\overline{S5}$  are logic high at the time the 5V<sub>SB</sub> is applied, the ISL6505 will assume active state wake-up and keep off the required outputs until some time (typically 50ms) after the monitored main ATX outputs (3.3V and 5V; 12V is not monitored here) exceed the set thresholds. This time-out feature is necessary in order to ensure the main ATX outputs are stabilized. The time-out also assures smooth transitions from sleep into active when sleep states

are being supported. 3.3V<sub>DUAL</sub>/3.3V<sub>SB</sub> and V<sub>OUT1</sub> outputs will come up right after bias voltage surpasses POR level (but if LAN = GND, then V<sub>OUT1</sub> output will not come up until the soft-start ramp, along with V<sub>OUT2</sub>; see Figure 9).

During sleep-to-active state transitions from conditions where the 5V<sub>DUAL</sub> output is initially GND (such as S5 to S0 transition, or simple power-up sequence directly into active state), the circuit goes through a quasi soft-start, the 5V<sub>DUAL</sub> output being pulled high through the body diode of the NMOS FET connected between it and the 5V ATX. Figure 9 exemplifies this start-up case. 5V<sub>SB</sub> is already present when the main ATX outputs are turned on, at time T0. As a result of +5V<sub>IN</sub> ramping up, the 5V<sub>DUAL</sub> output capacitors charge up through the body diode of Q5 (see Typical Application). At time T1, all main ATX outputs exceed the ISL6505's undervoltage thresholds, and the internal 50ms (typical) timer is initiated. At T2, the time-out initiates a soft-start, and the 1.2V voltage ID output is ramped-up, reaching regulation limits at time T3. Simultaneous with the beginning of this ramp-up, at time T2, the DLA pin is released, allowing the pull-up resistor to turn on Q3 and Q5, and bring the 5V<sub>DUAL</sub> output in regulation. Shortly after time T3, as the SS voltage reaches 3.0V, the soft-start capacitor is quickly discharged down to approximately 2.7V, where it remains until a valid sleep state request is received from the system.

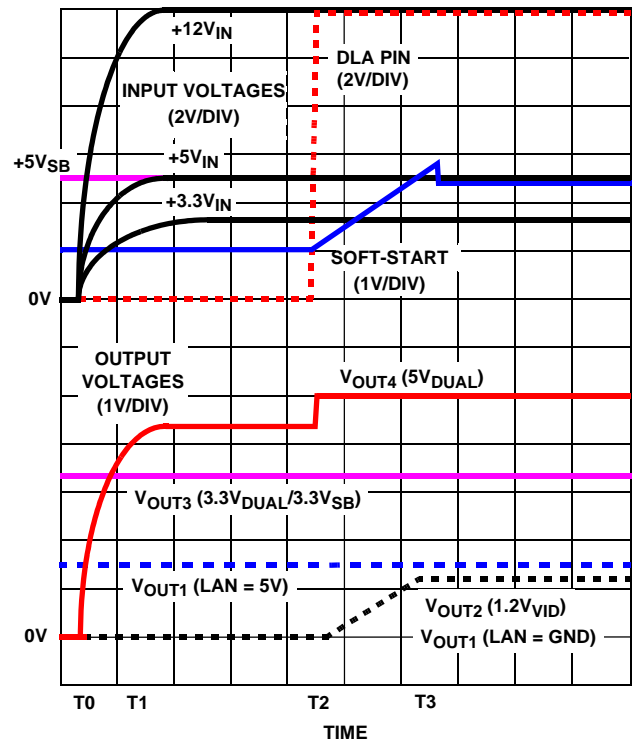

FIGURE 9. SOFT-START INTERVAL IN ACTIVE STATE

### Fault Protection

All of the outputs are monitored against undervoltage events. A severe overcurrent caused by a failed load on any of the outputs, would, in turn, cause that specific output to suddenly drop. If any of the output voltages drops below 80% (typical) of their set value, such event is reported by having the FAULT pin pulled to 5V. Additionally, exceeding the maximum current rating of an integrated regulator (output with pass transistor on-chip) can lead to output voltage drooping; if excessive, this droop can ultimately trip the undervoltage detector and send a FAULT signal to the computer system.

A FAULT condition occurring on an output when controlled through an external pass transistor will only set off the FAULT flag, and it will not shut off or latch off any part of the circuit. A FAULT condition occurring on an output controlled through an internal pass transistor (1V2VID only), will set off the FAULT flag, and it will shut off the respective faulting regulator (1V2VID only). If shutdown or latch off of the entire circuit is desired in case of a fault, regardless of the cause, this can be achieved by externally pulling or latching the SS pin low. Pulling the SS pin low will also force the FAULT pin to go low and reset any internally latched-off output.

Special consideration is given to the initial start-up sequence. If, following a 5V<sub>SB</sub> POR event, any of the V<sub>OUT1</sub> or 3.3V<sub>DUAL</sub>/3.3V<sub>SB</sub> outputs is ramped up and is subject to an undervoltage event before the end of the second soft-start ramp, then the FAULT output goes high and the entire IC latches off. Latch-off condition can be reset by cycling the bias power (5V<sub>SB</sub>). Undervoltage events on the V<sub>OUT1</sub> and the 3.3V<sub>DUAL</sub>/3.3V<sub>SB</sub> outputs at any other times are handled according to the description found in the second paragraph under the current heading.

Another condition that could set off the FAULT flag is chip overtemperature. If the ISL6505 reaches an internal temperature of 140°C (typical), the FAULT flag is set, but the chip continues to operate until the temperature reaches 155°C (typical), when unconditional shutdown of all outputs takes place. Operation resumes only after powering down the IC (to create a 5V<sub>SB</sub> POR event) and a start-up (assuming the cause of the fault has been removed; if not, as it heats up again, it will repeat the FAULT cycle).

In ISL6505 applications, loss of the active ATX output (3V3 or 5V, as detected by the on-board voltage monitor) during active state operation causes the chip to switch to S5 sleep state, in addition to reporting the input UV condition on the FAULT pin. Exiting from this forced S5 state can only be achieved by returning the faulting input voltage above its UV threshold, by resetting the chip through removal of 5V<sub>SB</sub> bias voltage, or by bringing the SS pin at a potential lower than 0.8V.

### Application Guidelines

#### Soft-Start Interval

The 5V<sub>SB</sub> output of a typical ATX supply is capable of 725mA, with newer models rated for 1.0A, and even 2.0A. During power-up in a sleep state, the 5V<sub>SB</sub> ATX output needs to provide sufficient current to charge up all the applicable output capacitors and, simultaneously, provide some amount of current to the output loads. Drawing excessive amounts of current from the 5V<sub>SB</sub> output of the ATX can lead to voltage collapse and induce a pattern of consecutive restarts with unknown effects on the system's behavior or health.

The built-in soft-start circuitry allows tight control of the slew-up speed of the output voltages controlled by the ISL6505, thus enabling power-ups free of supply drop-off events. Since the outputs are ramped up in a linear fashion, the current dedicated to charging the output capacitors can be calculated with the following formula:

$$I_{\text{COUT}} = \frac{I_{\text{SS}}}{C_{\text{SS}} \times V_{\text{BG}}} \times \sum (C_{\text{OUT}} \times V_{\text{OUT}}), \text{ ""}$$

where

I<sub>SS</sub> - soft-start current (typically 10μA)

C<sub>SS</sub> - soft-start capacitor

V<sub>BG</sub> - bandgap voltage (typically 1.26V)

∑(C<sub>OUT</sub> × V<sub>OUT</sub>) - sum of the products between the capacitance and the voltage of an output (total charge delivered to all outputs)

Due to the various system timing events and their interaction, it is recommended that the soft-start interval not be set to exceed 30ms. For most applications, a 0.1μF capacitor is recommended.

#### Shutdown

In case of a FAULT condition that might endanger the computer system, or at any other time, all the ISL6505 outputs can be shut down by pulling the SS pin below the specified shutdown level (typically 0.8V) with an open drain or open collector device capable of sinking a minimum of 2mA. Pulling the SS pin low effectively shuts down all the pass elements. Upon release of the SS pin, the ISL6505 undergoes a new soft-start cycle and resumes normal operation in accordance to the ATX supply and control pins status.

#### VID\_PG Delay

During power-up and initial soft-start, the VID\_PG and VID\_CT pins are held low. As the 1V2VID output exceeds its rising power-good threshold (typically 90% of its final value), the capacitor connected at the VID\_CT pin starts to charge up through the internal 10μA current source. As the voltage on this capacitor exceeds 1.25V, the open-collector VID\_PG pin is released and VID POWER GOOD status is thus reported.

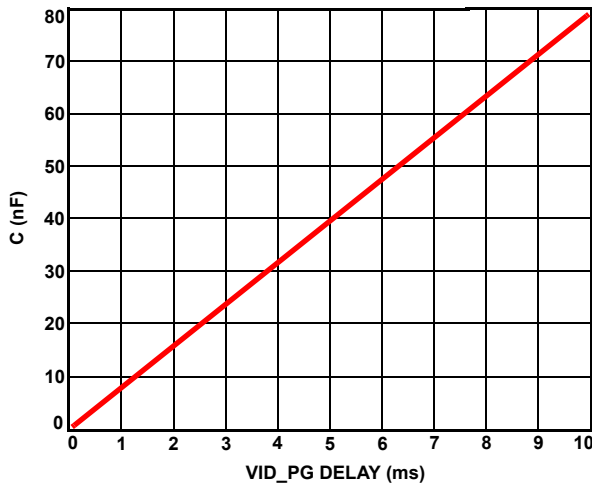

**FIGURE 10. VID\_PG DELAY DEPENDENCE ON VID\_CT CAPACITOR**

The value of the VID\_CT capacitor to be used to obtain a given VID\_PG delay can be determined from the graph in Figure 10. For extended delays exceeding the range of the graph, use the following formula:

$$C = \frac{t_{\text{DELAY}}}{125000}, \text{ where}$$

$t_{\text{DELAY}}$  - desired delay time (s)

C - VID\_CT capacitor to obtain desired delay time (F)

If no delay is needed, then a very small (pF) capacitor, or even no capacitor at all will generate a very short delay (just the pin capacitance of ~10pF should give a delay of ~1 $\mu$ s).

The value of the external VID\_PG pull-up resistor is determined by the trade-off between the pull-down current available from the pin versus the rise time needed. In the typical power-up sequence (as described above), the VID\_PG starts low (VID Power NOT Good) until the 1V2VID output reaches its power-good threshold (90%), which starts the VID\_CT pin charging. When that pin reaches its trip point, the VID\_PG pin open-drain pull-down device shuts off, and the external pull-up resistor (R2, as shown in Figure 13) will pull the output up to the positive supply (typically 1V2VID). This rise time is determined not by the ISL6505, but simply by the RC time constant of the pull-up resistor, and whatever capacitance is on the node, from the VID\_PG output pin to whatever signals it is driving, including the pin capacitances and all of the parasitics; this may vary from one system implementation to another.

The R2 value in Figure 13 (and on the ISL6505EVAL1/2 boards) is listed as 10k $\Omega$ , which may work fine in some systems. However, some of the newer systems may require a faster rise time than allowed by the 10k $\Omega$  resistor, so a lower value of resistance should be chosen. But the VID\_PG pin must be able to pull down low enough against the resistor to guarantee a low logic level for whatever control signals it is driving. Since the pin can nominally sink 1.2mA with only a 0.1V drop, a 1k $\Omega$  resistor will match that condition. The minimum input low logic level is typically

around 25-30% of the 1.2V supply (0.3V in this example), and the 0.1V is well below it. So a resistor pull-up value as low as 1k $\Omega$  is acceptable to get faster rise times.

### Linear Regulator ( $V_{\text{OUT1}}$ ) Compensation

$V_{\text{OUT1}}$  is a linear regulator, with an on-chip amplifier, and external FET and feedback resistors. The output capacitors should be selected to allow the output voltage to meet any dynamic regulation requirements, paying attention to their parasitic components ESR (Effective Series Resistance) and ESL (Effective Series inductance).

$V_{\text{OUT1}}$  is internally compensated to cover a wide range of load currents; however the output filter capacitor must be chosen carefully. Ideally, the capacitor value and its ESR combine to create a zero that cancels one of the amplifier poles. However, this is only a first order approximation, since that pole moves with load current, for example. In addition, there are high frequency poles that may come into play under certain conditions.

A lower capacitor ESR improves transient response. When the output load changes quickly (faster than the amplifier itself can respond), the differential load current is sourced or sunk by the capacitor, until the regulator can respond and catch up. In this case, the higher the ESR, the larger the voltage drop across it, and thus the larger the voltage transient on the output is.

However, lower output capacitor ESR pushes the zero frequency higher, reducing the regulator phase margin. Thus, it may be difficult to simultaneously satisfy both tight dynamic regulation and a good stable loop with high phase margin.

There are many factors that affect  $V_{\text{OUT1}}$  stability, such that a simple equation or formula is not practical. So the recommendation is to choose a value from Figure 11, which shows capacitance versus ESR. Values inside the polygon will result in stable conditions over a full load range of 10mA to 3A. Choosing a value outside the polygon is NOT recommended; it may work in some cases, but the margin may be much smaller. In addition, there are manufacturing tolerances (of both the IC and the capacitor), load variations, temperature, FET selection, and many other factors that can create the potential for problems.

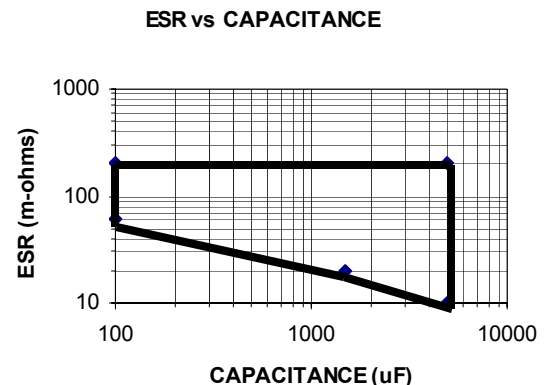

**FIGURE 11.  $V_{\text{OUT1}}$  OUTPUT CAPACITOR SELECTION**

### Other Considerations:

See COMPONENT SELECTION section for more details on choosing Q6. The minimum load assumed is 10mA. The maximum load is based primarily on the ability of the FET to dissipate the heat; for stability, the assumption was 3A.

The FET selection can affect the compensation. With light (or no) load, the gm of the FET is very low, and looks like a high series resistance to the load, thus reducing the loop gain, and moving the pole formed by the output capacitor down by as much as several decades. In addition, the FET input capacitance can vary from hundreds to thousands of pF; (higher gm FETs such as logic level FETs typically have a higher gate capacitance). The FET capacitance, along with the amplifier driver resistance is included in the stability calculations. Finally, the slewing of the FET gate (determined by its capacitance) affects the transient response. So a lot of the parameters are inter-related.

Note that the latest low-ESR ceramic capacitors are NOT well suited for this application; the ESR (typically only a few mΩ) is too low to be inside the polygon, for any typical value of capacitance.

### 1V2VID Regulator ( $V_{OUT2}$ ) Compensation

1V2VID is an on-chip linear regulator, which is internally compensated to cover loads up to its maximum rating of 180mA. However, the output capacitor choice can affect the stability. The recommendation is to use a tantalum (or similar) capacitor around 10μF (with high ESR in the 1-5mΩ range), in parallel with a ceramic 1μF capacitor (with low ESR in the 10mΩ range). The two capacitors (dominated by the tantalum) will create a zero that will help cancel the pole of the internal regulator; the ceramic capacitor will help the frequency response. Note that a single bigger ceramic capacitor is NOT recommended; the higher ESR is necessary.

### Layout Considerations

The typical application employing an ISL6505 is a fairly straight forward implementation. Like with any other linear regulator, attention has to be paid to the few potentially sensitive small signal components, such as those connected to sensitive nodes or those supplying critical bypass current.

The power components (pass transistors) and the controller IC should be placed first. The controller should be placed in a central position on the motherboard, closer to the memory controller chip and processor, but not excessively far from the 3.3V<sub>DUAL</sub> island or the I/O circuitry. Ensure the 1V2VID, 3V3, and 3V3DL connections are properly sized to carry 100mA without exhibiting significant resistive losses at the load end. Similarly, the input bias supply (5V<sub>SB</sub>) can carry a significant level of current - for best results, ensure it is connected to its respective source through an adequately sized trace. The pass transistors should be placed on pads capable of heatsinking matching the device's power dissipation. Where applicable, multiple via connections to a large internal plane can significantly lower localized device temperature rise.

Placement of the decoupling and bulk capacitors should follow a placement reflecting their purpose. As such, the high-

frequency decoupling capacitors should be placed as close as possible to the load they are decoupling; the ones decoupling the controller close to the controller pins, the ones decoupling the load close to the load connector or the load itself (if embedded). Even though bulk capacitance (aluminum electrolytics or tantalum capacitors) placement is not as critical as the high-frequency capacitor placement, having these capacitors close to the load they serve is preferable.

The critical small signal components include the soft-start capacitor, C<sub>SS</sub>, as well as all the high-frequency decoupling capacitors. Locate these components close to the respective pins of the control IC, and connect them to ground through a via placed close to the ground pad. Minimize any leakage current paths from the SS node, as the internal current source is only 10μA (typical).

A multi-layer printed circuit board is recommended.

Figure 12 shows the connections to most of the components in the circuit. Note that the individual capacitors shown each could represent numerous physical capacitors. Dedicate one solid layer for a ground plane and make all critical component ground connections through vias placed as close to the component terminal as possible. Dedicate another solid layer as a power plane and break this plane into smaller islands of common voltage levels. Ideally, the power plane should support both the input power and output power nodes. Use copper filled polygons on the top and bottom circuit layers to create power islands connecting the filtering components (output capacitors) and the loads. Use the remaining printed circuit layers for small signal wiring.

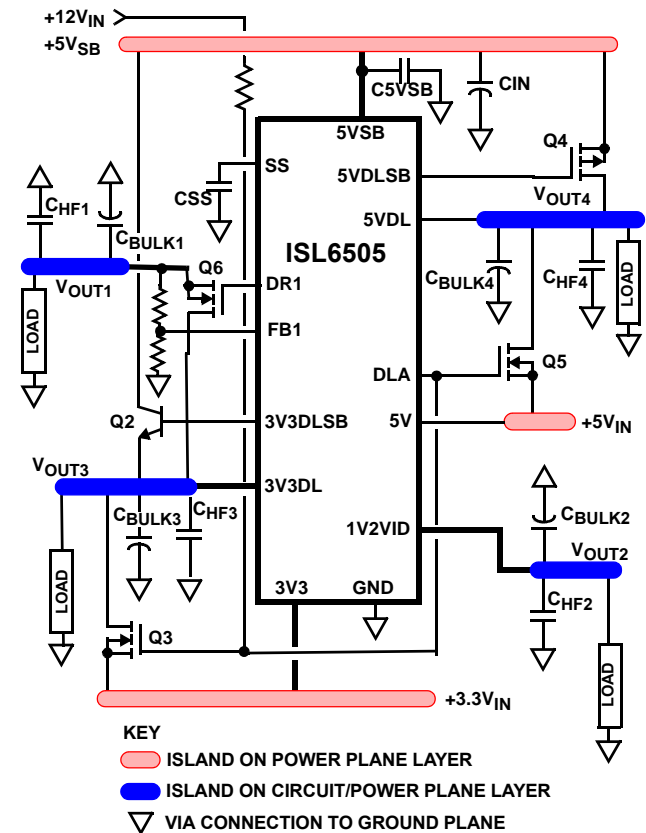

FIGURE 12. PRINTED CIRCUIT BOARD ISLANDS

## Component Selection Guidelines

### Output Capacitors Selection

The output capacitors should be selected to allow the output voltage to meet the dynamic regulation requirements of active state operation (S0, S1). The load transient for the various microprocessor system's components may require high quality capacitors to supply the high slew rate (di/dt) current demands. Thus, it is recommended that the output capacitors be selected for transient load regulation, paying attention to their parasitic components (ESR, ESL).

Also, during the transition between active and sleep states on the 3.3V<sub>DUAL</sub>/3.3V<sub>SB</sub> and 5V<sub>DUAL</sub> outputs, there is a short interval of time during which none of the power pass elements are conducting - during this time the output capacitors have to supply all the output current. The output voltage drop during this brief period of time can be easily approximated with the following formula:

$$\Delta V_{OUT} = I_{OUT} \times \left( ESR_{OUT} + \frac{t_t}{C_{OUT}} \right), \text{ where}$$

$\Delta V_{OUT}$  - output voltage drop

$ESR_{OUT}$  - output capacitor bank ESR

$I_{OUT}$  - output current during transition

$C_{OUT}$  - output capacitor bank capacitance

$t_t$  - active-to-sleep or sleep-to-active transition time (10 $\mu$ s typ.)

The output voltage drop is heavily dependent on the ESR (equivalent series resistance) of the output capacitor bank, the choice of capacitors should be such as to maintain the output voltage above the lowest allowable regulation level.

### Input Capacitors Selection

The input capacitors for an ISL6505 application must have a sufficiently low ESR so as not to allow the input voltage to dip excessively when energy is transferred to the output capacitors. If the ATX supply does not meet the specifications, certain imbalances between the ATX's outputs and the ISL6505's regulation levels could have as a result a brisk transfer of energy from the input capacitors to the supplied outputs. At the transition between active and sleep states, such phenomena could be responsible for the 5V<sub>SB</sub> voltage drooping excessively and affecting the output regulation. The solution to such a potential problem is using larger input capacitors with a lower total combined ESR.

### Transistor Selection/Considerations

The ISL6505 usually requires one P-Channel (or bipolar PNP), three N-Channel MOSFETs, and one bipolar NPN transistors. Note there is no Q1 listed below.

One important criteria for selection of transistors for all the linear regulators/switching elements is package selection for efficient removal of heat.

The power dissipated in a linear regulator or an ON/OFF switching element is

$$P_{LINEAR} = I_O \times (V_{IN} - V_{OUT})$$

Select a package and heatsink that maintains the junction temperature below the rating with the maximum expected ambient temperature.

### Q2

The NPN transistor used as sleep state pass element on the 3.3V<sub>DUAL</sub> output has to have a minimum current gain of 100 at 1.5V  $V_{CE}$  and 650mA  $I_{CE}$  throughout the in-circuit operating temperature range. For larger current ratings on the 3.3V<sub>DUAL</sub> output (providing the ATX 5V<sub>SB</sub> output rating is equally extended), selection criteria for Q2 include an appropriate current gain ( $h_{fe}$ ) and saturation characteristics.

### Q3, Q5

These NMOS FETs are used to switch the 3.3V and 5V inputs provided by the ATX supply into the 3.3V<sub>DUAL</sub>/3.3V<sub>SB</sub> and 5V<sub>DUAL</sub> outputs while in active (S0, S1) state. The main criteria for the selection of these transistors is output voltage budgeting. The maximum  $r_{DS(ON)}$  allowed at highest junction temperature can be expressed with the following equation:

$$r_{DS(ON)max} = \frac{V_{INmin} - V_{OUTmin}}{I_{OUTmax}}, \text{ where}$$

$V_{INmin}$  - minimum input voltage

$V_{OUTmin}$  - minimum output voltage allowed

$I_{OUTmax}$  - maximum output current

### Q4

If a PMOS FET is used to switch the 5V<sub>SB</sub> output of the ATX supply into the 5V<sub>DUAL</sub> output during sleep states, then the selection criteria of this device is proper voltage budgeting. The maximum  $r_{DS(ON)}$ , however, has to be achieved with only 4.5V of gate-to-source voltage, so a logic level MOSFET needs to be selected. If a PNP device is chosen to perform this function, it has to have a low- saturation voltage while providing the maximum sleep current and have a current gain sufficiently high to be saturated using the minimum drive current (typically 20mA).

### Q6

This NMOS FET acts as the pass transistor for the  $V_{OUT1}$  output. The input voltage to the source comes from 3.3V<sub>DUAL</sub>/3.3V<sub>SB</sub>; the output is expected to be in the 1.2V to 1.5V range, depending upon the external resistor divider. The power dissipation will  $(3.3V - V_{OUT1}) * I_{OUT1}$ , so the FET selection and mounting technique must be sufficient for that case.

In addition, Q6 must have a sufficiently low gate threshold voltage. The DR1 gate driver maximum voltage is limited to a  $V_{BE}$  below the 5V supply (5VSB pin), which itself can be as low as 4.5V. So the maximum driver voltage can be 3.8V (or even a few tenths of a volt lower, considering temperature effects of the  $V_{BE}$  drop). If the output voltage is 1.5V, then only 2.3V is available for the gate threshold, plus any overdrive needed to get the required output current out while close to the threshold. So a FET gate threshold voltage well below 2V is recommended.

Although the design intended to use a low threshold voltage FET for Q6, it is possible to use an NPN. The DR1 driver is rated at 10mA nominal, but the driver will only supply the current that is needed, up to 50mA; in that sense, it is more of a maximum spec. That means an NPN with a gain of 100 could deliver up to 1.0A, for example. The additional base current will come from the 5VSB pin, which adds some IC power dissipation, and may take away current needed elsewhere; it may also draw the extra current during sleep modes. But the NPN can be used, and it should be stable, using the same considerations for a FET.

The LAN pin determines the timing and the on state of the regulator; when LAN is high (5V) or open,  $V_{OUT1}$  stays on all of the time. The input current comes from 3.3V<sub>DUAL</sub>/3.3V<sub>SB</sub>, which indirectly comes from 3V3 during active modes, and from the 3.3V<sub>SB</sub> regulator (which ultimately comes from 5V<sub>SB</sub>); thus, the  $V_{OUT1}$  current is limited in sleep mode to whatever current the 5V<sub>SB</sub> has left, after all other currents are accounted for. The current in active mode can be higher, limited mainly by the dissipation of the FET.

When the LAN pin is low, then  $V_{OUT1}$  is on only during active states, where the input voltage is ultimately 3V3. So again, the current is limited mainly by the dissipation of the FET.

### **Resistors R20, R21**

These two act as a resistor divider off the  $V_{OUT1}$  output; the common connection is brought into the FB1 pin. Use the following equation to determine them:

$$V_{OUT1} = 0.8V * (R20 + R21)/R21.$$

$V_{OUT1}$  is expected to be between 1.2V and 1.5V. Note that the undervoltage detection for this output will be typically 80% of whatever the output voltage is set at.

The sum of (R20 + R21) should equal approximately 1.2 to 1.5k $\Omega$ , in order to draw about 1mA of current. If the current is too low (resistors are too high in value), there might be a small offset error due to the input current of the FB1 pin. On the other extreme, the current can go as high as 10mA, in order to meet the minimum load current requirement.

$C_{OUT1}$  should be chosen as explained in the Linear Regulator ( $V_{OUT1}$ ) Compensation section.

## Application Circuit

Figure 13 shows a typical application circuit for the ISL6505.

The circuit provides the 3.3V<sub>DUAL</sub>/3.3V<sub>SB</sub> voltage, the Ethernet/LAN V<sub>OUT1</sub> voltage, the 1.2V<sub>VID</sub> voltage identification output, and the 5V<sub>DUAL</sub> keyboard/mouse voltage from +3.3V, +5V<sub>SB</sub>, +5V, and +12VDC ATX supply

outputs. Q4 can also be a PNP transistor, such as an MMBT2907AL. For additional, more detailed information on the circuit, including a Bill-of-Materials and circuit board description, see Application Note AN1053. Also see Intersil Corporation's web page ([www.intersil.com](http://www.intersil.com)).

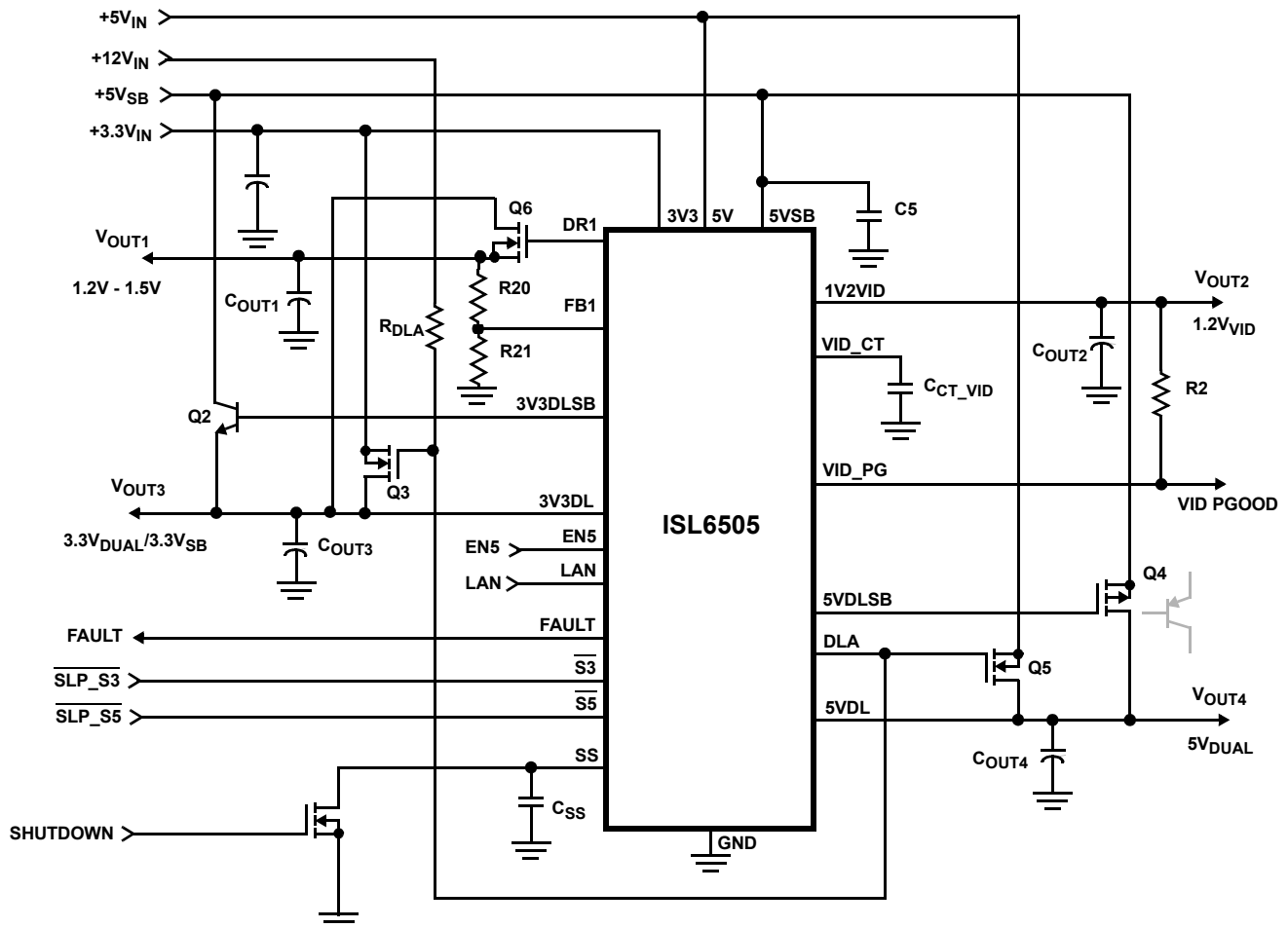

V<sub>OUT1</sub> = 1.2V to 1.5V: Q6 = FDD6530A, C<sub>OUT1</sub> = 1000μF

V<sub>OUT2</sub> = 1.2V: internal FET, C<sub>OUT2</sub> = 10μF

V<sub>OUT3</sub> = 3.3V: Q2 = 2SD1802, Q3 = FDT459N, C<sub>OUT3</sub> = 330μF

V<sub>OUT4</sub> = 5.0V: Q4 = FDV340P, Q5 = FDT459N, C<sub>OUT4</sub> = 220μF

NOTE: Outputs may also require small (1μF) high frequency capacitors.

C<sub>CT\_VID</sub> = 0.1μF

C<sub>SS</sub> = 0.1μF

C5 = 1.0μF

R<sub>DLA</sub> = 1K

R2 = 10K

FIGURE 13. TYPICAL ISL6505 APPLICATION DIAGRAM

**Quad Flat No-Lead Plastic Package (QFN)  
Micro Lead Frame Plastic Package (MLFP)**

**L20.5x5**

20 LEAD QUAD FLAT NO-LEAD PLASTIC PACKAGE  
(COMPLIANT TO JEDEC MO-220VHHC ISSUE C)

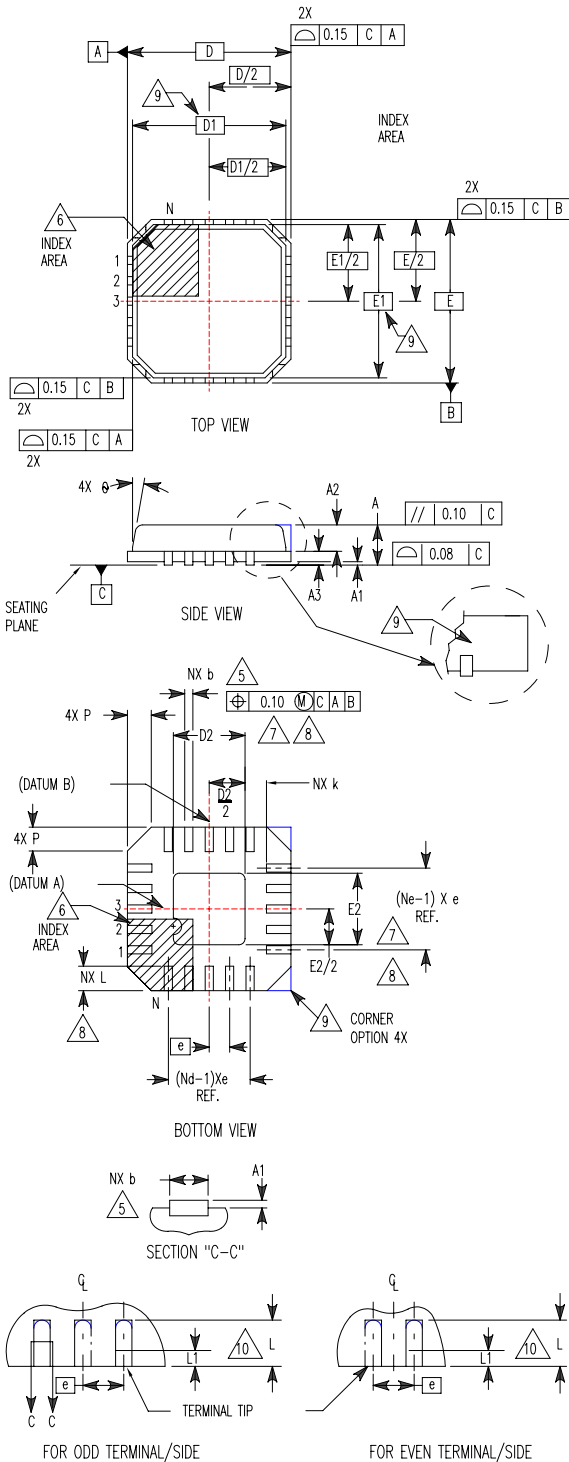

SYMBOL	MILLIMETERS			NOTES
	MIN	NOMINAL	MAX	
A	0.80	0.90	1.00	-
A1	-	-	0.05	-
A2	-	-	1.00	9
A3	0.20 REF			9
b	0.23	0.28	0.38	5, 8
D	5.00 BSC			-
D1	4.75 BSC			9
D2	2.95	3.10	3.25	7, 8
E	5.00 BSC			-
E1	4.75 BSC			9
E2	2.95	3.10	3.25	7, 8
e	0.65 BSC			-
k	0.25	-	-	-
L	0.35	0.60	0.75	8
L1	-	-	0.15	10
N	20			2
Nd	5			3
Ne	5			3
P	-	-	0.60	9
θ	-	-	12	9

Rev. 3 10/02

**NOTES:**

1. Dimensioning and tolerancing conform to ASME Y14.5-1994.
2. N is the number of terminals.
3. Nd and Ne refer to the number of terminals on each D and E.
4. All dimensions are in millimeters. Angles are in degrees.
5. Dimension b applies to the metallized terminal and is measured between 0.15mm and 0.30mm from the terminal tip.
6. The configuration of the pin #1 identifier is optional, but must be located within the zone indicated. The pin #1 identifier may be either a mold or mark feature.
7. Dimensions D2 and E2 are for the exposed pads which provide improved electrical and thermal performance.
8. Nominal dimensions are provided to assist with PCB Land Pattern Design efforts, see Intersil Technical Brief TB389.
9. Features and dimensions A2, A3, D1, E1, P & θ are present when Anvil singulation method is used and not present for saw singulation.
10. Depending on the method of lead termination at the edge of the package, a maximum 0.15mm pull back (L1) maybe present. L minus L1 to be equal to or greater than 0.3mm.

**Small Outline Plastic Packages (SOIC)**

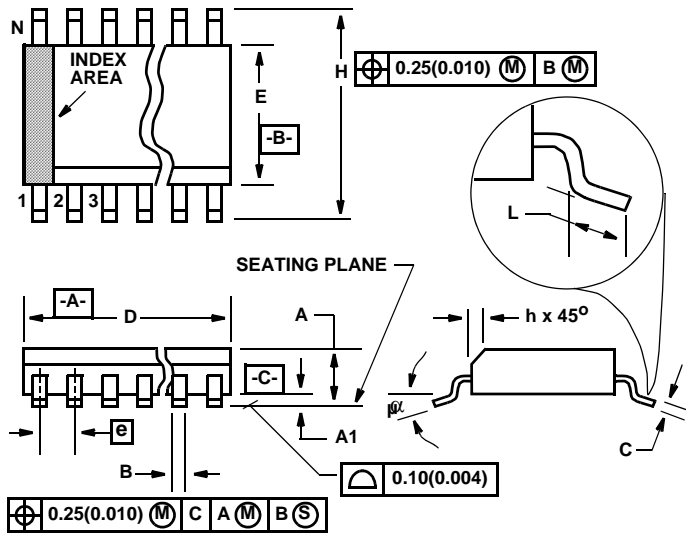

**M20.3 (JEDEC MS-013-AC ISSUE C)  
20 LEAD WIDE BODY SMALL OUTLINE PLASTIC PACKAGE**

SYMBOL	INCHES		MILLIMETERS		NOTES
	MIN	MAX	MIN	MAX	
A	0.0926	0.1043	2.35	2.65	-
A1	0.0040	0.0118	0.10	0.30	-
B	0.014	0.019	0.35	0.49	9
C	0.0091	0.0125	0.23	0.32	-
D	0.4961	0.5118	12.60	13.00	3
E	0.2914	0.2992	7.40	7.60	4
e	0.050 BSC		1.27 BSC		-
H	0.394	0.419	10.00	10.65	-
h	0.010	0.029	0.25	0.75	5
L	0.016	0.050	0.40	1.27	6
N	20		20		7
$\alpha$	0°	8°	0°	8°	-

Rev. 1 1/02

**NOTES:**

1. Symbols are defined in the "MO Series Symbol List" in Section 2.2 of Publication Number 95.
2. Dimensioning and tolerancing per ANSI Y14.5M-1982.
3. Dimension "D" does not include mold flash, protrusions or gate burrs. Mold flash, protrusion and gate burrs shall not exceed 0.15mm (0.006 inch) per side.
4. Dimension "E" does not include interlead flash or protrusions. Interlead flash and protrusions shall not exceed 0.25mm (0.010 inch) per side.
5. The chamfer on the body is optional. If it is not present, a visual index feature must be located within the crosshatched area.
6. "L" is the length of terminal for soldering to a substrate.
7. "N" is the number of terminal positions.
8. Terminal numbers are shown for reference only.
9. The lead width "B", as measured 0.36mm (0.014 inch) or greater above the seating plane, shall not exceed a maximum value of 0.61mm (0.024 inch)
10. Controlling dimension: MILLIMETER. Converted inch dimensions are not necessarily exact.

All Intersil U.S. products are manufactured, assembled and tested utilizing ISO9000 quality systems. Intersil Corporation's quality certifications can be viewed at [www.intersil.com/design/quality](http://www.intersil.com/design/quality)

*Intersil products are sold by description only. Intersil Corporation reserves the right to make changes in circuit design, software and/or specifications at any time without notice. Accordingly, the reader is cautioned to verify that data sheets are current before placing orders. Information furnished by Intersil is believed to be accurate and reliable. However, no responsibility is assumed by Intersil or its subsidiaries for its use; nor for any infringements of patents or other rights of third parties which may result from its use. No license is granted by implication or otherwise under any patent or patent rights of Intersil or its subsidiaries.*

For information regarding Intersil Corporation and its products, see [www.intersil.com](http://www.intersil.com)

This datasheet has been downloaded from:

[www.DatasheetCatalog.com](http://www.DatasheetCatalog.com)

Datasheets for electronic components.



LittleDiode supplies new, hard to find or obsolete electronic components and semiconductors all over the world.

With over two million different components listed you are sure to find the part you need.

Feel free to visit us today at our online store:

[LittleDiode.com](http://LittleDiode.com)

Looking forward to providing you with the best possible service.