

**±15kV ESD Protected, +3V to +5.5V,  
1 Microamp, 250kbps, RS-232  
Transmitters/Receivers with Separate  
Logic Supply**

The ISL83386E contains 3.0V to 5.5V powered RS-232 transmitters/receivers which meet EIA/TIA-232 and V.28/V.24 specifications, even at  $V_{CC} = 3.0V$ . Targeted applications are PDAs, Palmtops, and cell phones where the low operational, and even lower standby, power consumption is critical. Efficient on-chip charge pumps, coupled with a manual powerdown function reduces the standby supply current to a 1 $\mu$ A trickle. Small footprint packaging, and the use of small, low value capacitors ensure board space savings as well. Data rates greater than 250kbps are guaranteed at worst case load conditions.

The ISL83386E features a  $V_L$  pin that adjusts the logic pin (see Pin Descriptions table) output levels and input thresholds to values compatible with the  $V_{CC}$  powering the external logic (e.g., a UART).

The single pin powerdown function ( $\overline{SHDN} = 0$ ) disables all the receiver and transmitter outputs, while shutting down the charge pump to minimize supply current drain.

Table 1 summarizes the features of the ISL83386E, while Application Note AN9863 summarizes the features of each device comprising the 3V RS-232 family.

**Ordering Information**

PART NUMBER (BRAND)	TEMP. RANGE (°C)	PACKAGE	PKG. NO.
ISL83386EIV (83386EIV)	-40 to 85	20 Ld TSSOP	M20.173
ISL83386EIV-T (83386EIV)	-40 to 85	Tape and Reel	M20.173

**TABLE 1. SUMMARY OF FEATURES**

PART NUMBER	NO. OF Tx.	NO. OF Rx.	DATA RATE (kbps)	Rx. ENABLE FUNCTION?	$V_L$ LOGIC SUPPLY PIN?	MANUAL POWER-DOWN?	AUTOMATIC POWERDOWN FUNCTION?
ISL83386E	3	2	250	NO	YES	YES	NO

**Features**

- $V_L$  Pin for Compatibility with Mixed Voltage Systems
- ESD Protection for RS-232 I/O Pins to ±15kV (IEC61000)
- Low Power, Pin Compatible Upgrade for MAX3386E and SP3203E
- Single  $\overline{SHDN}$  Pin Disables Transmitters and Receivers
- Meets EIA/TIA-232 and V.28/V.24 Specifications at 3V
- On-Chip Charge Pumps Require Only Four External 0.1 $\mu$ F Capacitors
- Receiver Hysteresis For Improved Noise Immunity
- Very Low Supply Current . . . . . 300 $\mu$ A
- Guaranteed Minimum Data Rate . . . . . 250kbps
- Wide Power Supply Range. . . . . Single +3V to +5.5V
- Low Supply Current in Powerdown State . . . . . < 1 $\mu$ A

**Applications**

- Any System Requiring RS-232 Communication Ports
  - Battery Powered, Hand-Held, and Portable Equipment
  - Laptop Computers, Notebooks, Palmtops
  - Digital Cameras
  - PDA's and PDA Cradles
  - Cellular/Mobile Phones

Pinout

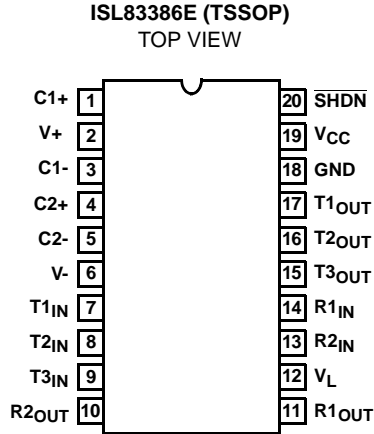

Pin Descriptions

PIN	FUNCTION
V <sub>CC</sub>	System power supply input (3.0V to 5.5V).
V+	Internally generated positive transmitter supply (+5.5V).
V-	Internally generated negative transmitter supply (-5.5V).
GND	Ground connection.
C1+	External capacitor (voltage doubler) is connected to this lead.
C1-	External capacitor (voltage doubler) is connected to this lead.
C2+	External capacitor (voltage inverter) is connected to this lead.
C2-	External capacitor (voltage inverter) is connected to this lead.
T <sub>IN</sub>	TTL/CMOS compatible transmitter Inputs. The switching point is a function of the V <sub>L</sub> voltage.
T <sub>OUT</sub>	±15kV ESD Protected, RS-232 level (nominally ±5.5V) transmitter outputs.
R <sub>IN</sub>	±15kV ESD Protected, RS-232 compatible receiver inputs.
R <sub>OUT</sub>	TTL/CMOS level receiver outputs. Swings between GND and V <sub>L</sub> .
V <sub>L</sub>	Logic-Level Supply. All TTL/CMOS inputs and outputs are powered by this supply.
SHDN	Active low TTL/CMOS input to tri-state receiver and transmitter outputs and to shut down the on-board power supply to place device in low power mode. The switching point is a function of the V <sub>L</sub> voltage.

Typical Operating Circuit

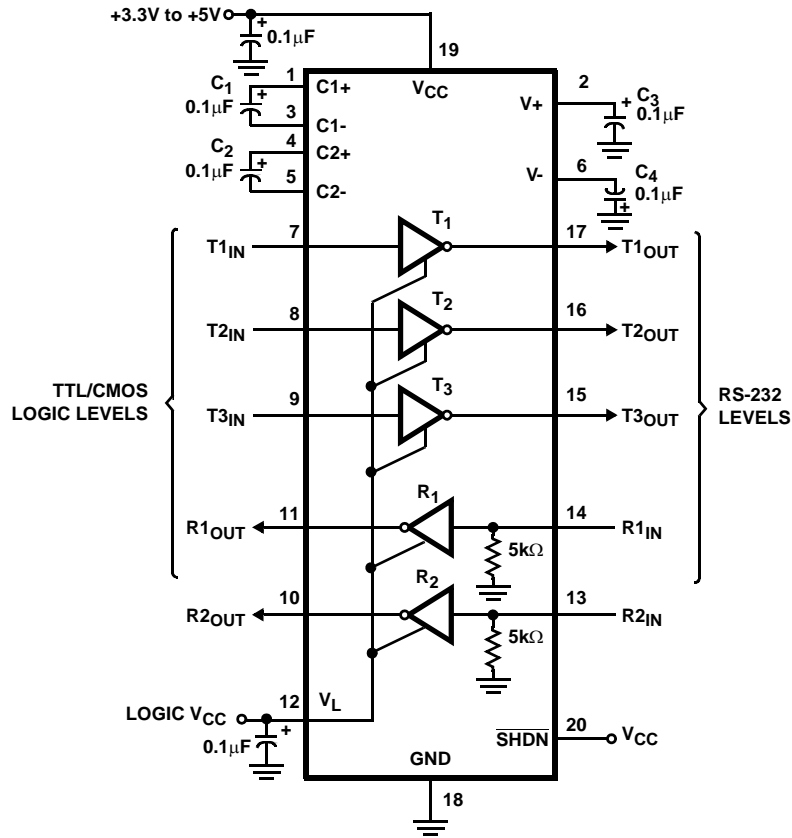

**Absolute Maximum Ratings**

V <sub>CC</sub> to Ground	-0.3V to 6V
V <sub>L</sub> to Ground	-0.3V to 7V
V <sub>+</sub> to Ground	-0.3V to 7V
V <sub>-</sub> to Ground	+0.3V to -7V
V <sub>+</sub> to V <sub>-</sub>	14V
Input Voltages	
T <sub>IN</sub> , $\overline{\text{SHDN}}$	-0.3V to 6V
R <sub>IN</sub>	±25V
Output Voltages	
T <sub>OUT</sub>	±13.2V
R <sub>OUT</sub>	-0.3V to (V <sub>L</sub> + 0.3V)
Short Circuit Duration	
T <sub>OUT</sub>	Continuous
ESD Rating See Specification Table	

**Thermal Information**

Thermal Resistance (Typical, Note 1)	θ <sub>JA</sub> (°C/W)
20 Ld TSSOP Package	140
Moisture Sensitivity (see Technical Brief TB363)	
TSSOP Package	Level 1
Maximum Junction Temperature (Plastic Package)	150°C
Maximum Storage Temperature	-65°C to 150°C
Maximum Lead Temperature (Soldering 10s)	300°C
(Lead Tips Only)	

**Operating Conditions**

Temperature Range	
ISL83386EIV	-40°C to 85°C

CAUTION: Stresses above those listed in "Absolute Maximum Ratings" may cause permanent damage to the device. This is a stress only rating and operation of the device at these or any other conditions above those indicated in the operational sections of this specification is not implied.

NOTE:

1. θ<sub>JA</sub> is measured with the component mounted on a low effective thermal conductivity test board in free air. See Tech Brief TB379 for details.

**Electrical Specifications** Test Conditions: V<sub>CC</sub> = 3V to 5.5V, C<sub>1</sub> - C<sub>4</sub> = 0.1µF, V<sub>L</sub> = V<sub>CC</sub>; Unless Otherwise Specified.  
Typicals are at T<sub>A</sub> = 25°C, V<sub>CC</sub> = V<sub>L</sub> = 3.3V

PARAMETER	TEST CONDITIONS	TEMP (°C)	MIN	TYP	MAX	UNITS
<b>DC CHARACTERISTICS</b>						
Supply Current, Powerdown	$\overline{\text{SHDN}}$ = GND, All Inputs at V <sub>CC</sub> or GND	25	-	1	10	µA
Supply Current	All Outputs Unloaded, $\overline{\text{SHDN}}$ = V <sub>CC</sub> , V <sub>CC</sub> = 3.15V	25	-	0.3	1	mA
<b>LOGIC AND TRANSMITTER INPUTS</b>						
Input Logic Threshold Low	T <sub>IN</sub> , $\overline{\text{SHDN}}$	V <sub>L</sub> = 3.3V or 5V	Full	-	-	0.8 V
		V <sub>L</sub> = 2.5V	Full	-	-	0.6 V
Input Logic Threshold High	T <sub>IN</sub> , $\overline{\text{SHDN}}$	V <sub>L</sub> = 5V	Full	2.4	-	- V
		V <sub>L</sub> = 3.3V	Full	2.0	-	- V
		V <sub>L</sub> = 2.5V	Full	1.4	-	- V
		V <sub>L</sub> = 1.8V	25	-	0.9	- V
Transmitter Input Hysteresis		25	-	0.5	-	V
Input Leakage Current	T <sub>IN</sub> , $\overline{\text{SHDN}}$	Full	-	±0.01	±1	µA
<b>RECEIVER OUTPUTS</b>						
Output Leakage Current	V <sub>CC</sub> = 0V or 3V to 5.5V, $\overline{\text{SHDN}}$ = GND	Full	-	±0.05	±10	µA
Output Voltage Low	I <sub>OUT</sub> = 1.6mA	Full	-	-	0.4	V
Output Voltage High	I <sub>OUT</sub> = -1.0mA	Full	V <sub>L</sub> - 0.6	V <sub>L</sub> - 0.1	-	V
<b>RECEIVER INPUTS</b>						
Input Voltage Range		Full	-25	-	25	V
Input Threshold Low	V <sub>L</sub> = 5.0V	25	0.8	1.5	-	V
	V <sub>L</sub> = 3.3V	25	0.6	1.2	-	V
Input Threshold High	V <sub>L</sub> = 5.0V	25	-	1.8	2.4	V
	V <sub>L</sub> = 3.3V	25	-	1.5	2.4	V
Input Hysteresis		25	-	0.5	-	V
Input Resistance		25	3	5	7	kΩ

**Electrical Specifications** Test Conditions:  $V_{CC} = 3V$  to  $5.5V$ ,  $C_1 - C_4 = 0.1\mu F$ ,  $V_L = V_{CC}$ ; Unless Otherwise Specified. Typical values are at  $T_A = 25^\circ C$ ,  $V_{CC} = V_L = 3.3V$  (Continued)

PARAMETER	TEST CONDITIONS	TEMP (°C)	MIN	TYP	MAX	UNITS	
<b>TRANSMITTER OUTPUTS</b>							
Output Voltage Swing	All Transmitter Outputs Loaded with $3k\Omega$ to Ground	Full	$\pm 5.0$	$\pm 5.4$	-	V	
Output Resistance	$V_{CC} = V_+ = V_- = 0V$ , Transmitter Output = $\pm 2V$	Full	300	10M	-	$\Omega$	
Output Short-Circuit Current	Shorted to GND	Full	-	-	$\pm 60$	mA	
Output Leakage Current	$V_{OUT} = \pm 12V$ , $V_{CC} = 0V$ or $3V$ to $5.5V$ , $\overline{SHDN} = GND$	Full	-	-	$\pm 25$	$\mu A$	
<b>TIMING CHARACTERISTICS</b>							
Maximum Data Rate	$R_L = 3k\Omega$ , $C_L = 1000pF$ , One Transmitter Switching	Full	250	500	-	kbps	
Receiver Propagation Delay	Receiver Input to Receiver Output, $C_L = 150pF$	$t_{PHL}$	25	-	0.15	-	$\mu s$
		$t_{PLH}$	25	-	0.15	-	$\mu s$
Receiver Output Enable Time		25	-	200	-	ns	
Receiver Output Disable Time		25	-	200	-	ns	
Transmitter Output Enable Time	From $\overline{SHDN}$ Rising Edge to $T_{OUT} = \pm 3.7V$	25	-	100	-	$\mu s$	
Transmitter Skew	$t_{PHL} - t_{PLH}$ (Note 2)	25	-	100	-	ns	
Receiver Skew	$t_{PHL} - t_{PLH}$	25	-	50	-	ns	
Transition Region Slew Rate	$R_L = 3k\Omega$ to $7k\Omega$ , Measured From $3V$ to $-3V$ or $-3V$ to $3V$ , $V_{CC} = 3.3V$	$C_L = 150pF$ to $1000pF$	25	6	18	30	$V/\mu s$
		$C_L = 150pF$ to $2500pF$	25	4	13	30	$V/\mu s$
<b>ESD PERFORMANCE</b>							
RS-232 Pins ( $T_{OUT}$ , $R_{IN}$ )	Human Body Model	25	-	$\pm 15$	-	kV	
	IEC61000-4-2 Air Gap Discharge	25	-	$\pm 15$	-	kV	
	IEC61000-4-2 Contact Discharge	25	-	$\pm 8$	-	kV	

NOTE:

- Transmitter skew is measured at the transmitter zero crossing points.

### Detailed Description

The ISL83386E operates from a single +3V to +5.5V supply, guarantees a 250kbps minimum data rate, requires only four small external  $0.1\mu F$  capacitors, features low power consumption, and meets all EIA RS-232C and V.28 specifications. The circuit is divided into three sections: The charge pump, the transmitters, and the receivers.

#### Charge-Pump

Intersil's new ISL83386E utilizes regulated on-chip dual charge pumps as voltage doublers, and voltage inverters to generate  $\pm 5.5V$  transmitter supplies from a  $V_{CC}$  supply as low as  $3.0V$ . This allows these devices to maintain RS-232 compliant output levels over the  $\pm 10\%$  tolerance range of  $3.3V$  powered systems. The efficient on-chip power supplies require only four small, external  $0.1\mu F$  capacitors for the voltage doubler and inverter functions over the full  $V_{CC}$  range; other capacitor combinations can be used as shown in Table 3. The charge pumps operate discontinuously (i.e., they turn off as soon as the  $V_+$  and  $V_-$  supplies are pumped

up to the nominal values), resulting in significant power savings.

#### Transmitters

The transmitters are proprietary, low dropout, inverting drivers that translate TTL/CMOS inputs to EIA/TIA-232 output levels. Coupled with the on-chip  $\pm 5.5V$  supplies, these transmitters deliver true RS-232 levels over a wide range of single supply system voltages.

All transmitter outputs disable and assume a high impedance state when the device enters the powerdown mode (see Table 2). These outputs may be driven to  $\pm 12V$  when disabled.

All devices guarantee a 250kbps data rate for full load conditions ( $3k\Omega$  and  $1000pF$ ),  $V_{CC} \geq 3.0V$ , with one transmitter operating at full speed. Under more typical conditions of  $V_{CC} \geq 3.3V$ ,  $R_L = 3k\Omega$ , and  $C_L = 250pF$ , one transmitter easily operates at 1.25Mbps.

The transmitter input threshold is set by the voltage applied to the  $V_L$  pin. Transmitter inputs float if left unconnected

(there are no pull-up resistors), and may cause  $I_{CC}$  increases. Connect unused inputs to GND for the best performance.

TABLE 2. POWERDOWN TRUTH TABLE

SHDN INPUT	TRANSMITTER OUTPUTS	RECEIVER OUTPUTS	MODE OF OPERATION
L	High-Z	High-Z	Manual Powerdown
H	Active	Active	Normal Operation

**Receivers**

The ISL83386E contains standard inverting receivers that convert RS-232 signals to CMOS output levels and accept inputs up to  $\pm 25V$  while presenting the required  $3k\Omega$  to  $7k\Omega$  input impedance (see Figure 1) even if the power is off ( $V_{CC} = 0V$ ). The receivers' Schmitt trigger input stage uses hysteresis to increase noise immunity and decrease errors due to slow input signal transitions. Receiver outputs swing from GND to  $V_L$ , and tristate in powerdown.

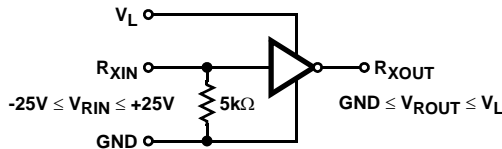

FIGURE 1. RECEIVER CONNECTIONS

**Low Power Operation**

This 3V device requires a nominal supply current of 0.3mA, even at  $V_{CC} = 5.5V$ , during normal operation (not in powerdown mode). This is considerably less than the 11mA current required by comparable 5V RS-232 devices, allowing users to reduce system power simply by replacing the old style device with the ISL83386E in new designs.

**Powerdown Functionality**

The already low current requirement drops significantly when the device enters powerdown mode. In powerdown, supply current drops to  $1\mu A$ , because the on-chip charge pump turns off ( $V+$  collapses to  $V_{CC}$ ,  $V-$  collapses to GND), and the transmitter and receiver outputs tristate. This micro-power mode makes these devices ideal for battery powered and portable applications.

**Software Controlled (Manual) Powerdown**

The ISL83386E may be forced into its low power, standby state via a simple shutdown ( $\overline{SHDN}$ ) pin (see Figure 2). Driving this pin high enables normal operation, while driving it low forces the IC into its powerdown state. The time required to exit powerdown, and resume transmission is less than  $100\mu s$ . Connect  $\overline{SHDN}$  to  $V_{CC}$  if the powerdown function isn't needed.

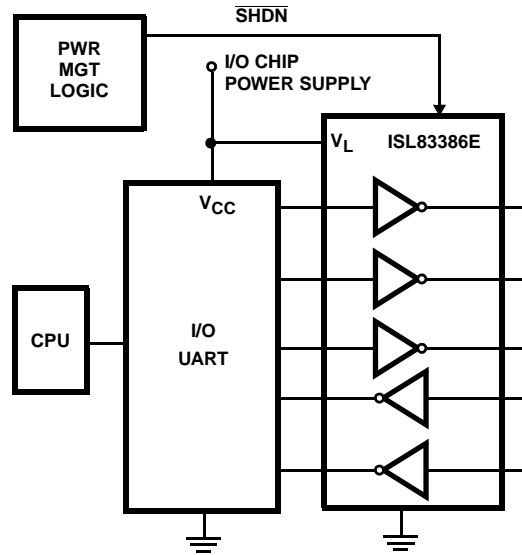

FIGURE 2. CONNECTIONS FOR MANUAL POWERDOWN

**VL Logic Supply Input**

Unlike other RS-232 interface devices where the CMOS outputs swing between 0 and  $V_{CC}$ , the ISL83386E features a separate logic supply input ( $V_L$ ; 1.8V to 5V, regardless of  $V_{CC}$ ) that sets  $V_{OH}$  for the receiver outputs. Connecting  $V_L$  to a host logic supply lower than  $V_{CC}$ , prevents the ISL83386E outputs from forward biasing the input diodes of a logic device powered by that lower supply. Connecting  $V_L$  to a logic supply greater than  $V_{CC}$  ensures that the receiver output levels are compatible even with the CMOS input  $V_{IH}$  of AC, HC, and CD4000 devices. Note that the  $V_L$  supply current increases to  $100\mu A$  with  $V_L = 5V$  and  $V_{CC} = 3.3V$  (see Figure 11).  $V_L$  also powers the transmitter and logic inputs, thereby setting their switching thresholds to levels compatible with the logic supply. This separate logic supply pin allows a great deal of flexibility in interfacing to systems with different logic supplies. If logic translation isn't required, connect  $V_L$  to the ISL83386E  $V_{CC}$ .

**Capacitor Selection**

The ISL83386E charge pumps only require  $0.1\mu F$  capacitors for the full operational voltage range. Table 3 lists other acceptable capacitor values for various supply voltage ranges. Do not use values smaller than those listed in Table 3. Increasing the capacitor values (by a factor of 2) reduces ripple on the transmitter outputs and slightly reduces power consumption.

TABLE 3. REQUIRED CAPACITOR VALUES

$V_{CC}$ (V)	$C_1$ ( $\mu F$ )	$C_2, C_3, C_4$ ( $\mu F$ )
3.0 to 3.6	0.1	0.1
4.5 to 5.5	0.047	0.33
3.0 to 5.5	0.22	1

When using minimum required capacitor values, make sure that capacitor values do not degrade excessively with temperature. If in doubt, use capacitors with a larger nominal value. The capacitor's equivalent series resistance (ESR) usually rises at low temperatures and it influences the amount of ripple on V+ and V-.

**Power Supply Decoupling**

In most circumstances a 0.1µF bypass capacitor is adequate. In applications that are particularly sensitive to power supply noise, decouple V<sub>CC</sub> to ground with a capacitor of the same value as the charge-pump capacitor C<sub>1</sub>. Connect the bypass capacitor as close as possible to the IC.

**Transmitter Outputs when Exiting Powerdown**

Figure 3 shows the response of two transmitter outputs when exiting powerdown mode. As they activate, the two transmitter outputs properly go to opposite RS-232 levels, with no glitching, ringing, or undesirable transients. Each transmitter is loaded with 3kΩ in parallel with 2500pF. Note that the transmitters enable only when the magnitude of the supplies exceed approximately 3V.

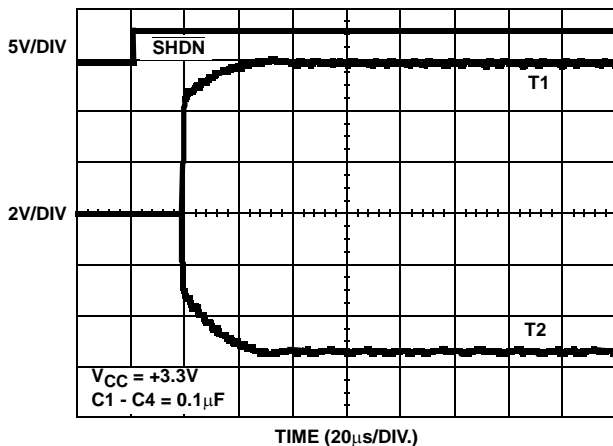

FIGURE 3. TRANSMITTER OUTPUTS WHEN EXITING POWERDOWN

**High Data Rates**

The ISL83386E maintains the RS-232 ±5V minimum transmitter output voltages even at high data rates. Figure 4 details a transmitter loopback test circuit, and Figure 5 illustrates the loopback test result at 120kbps. For this test, all transmitters were simultaneously driving RS-232 loads in parallel with 1000pF, at 120kbps. Figure 6 shows the loopback results for a single transmitter driving 1000pF and an RS-232 load at 250kbps. The static transmitters were also loaded with an RS-232 receiver.

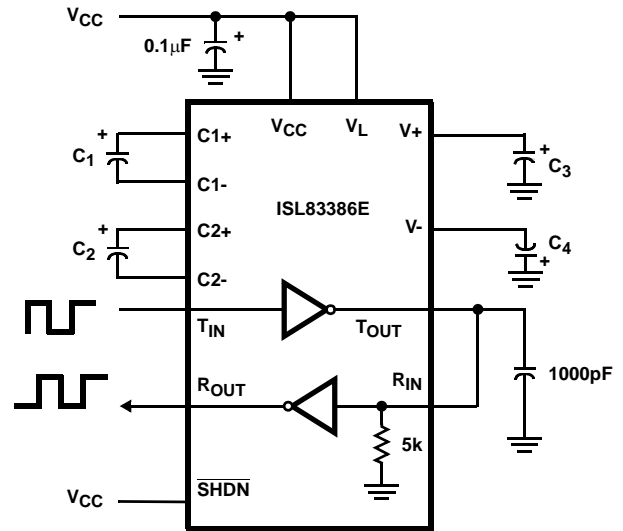

FIGURE 4. TRANSMITTER LOOPBACK TEST CIRCUIT

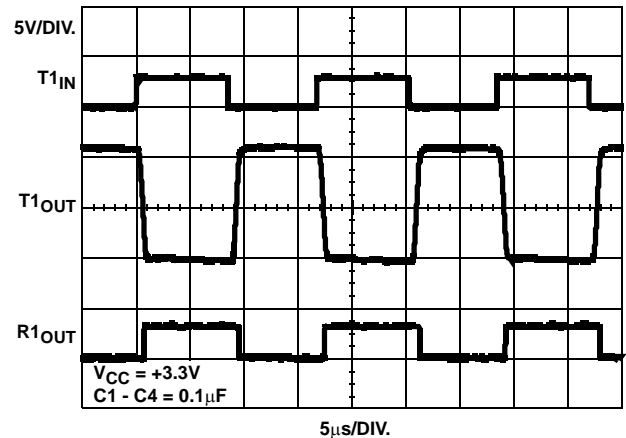

FIGURE 5. LOOPBACK TEST AT 120kbps

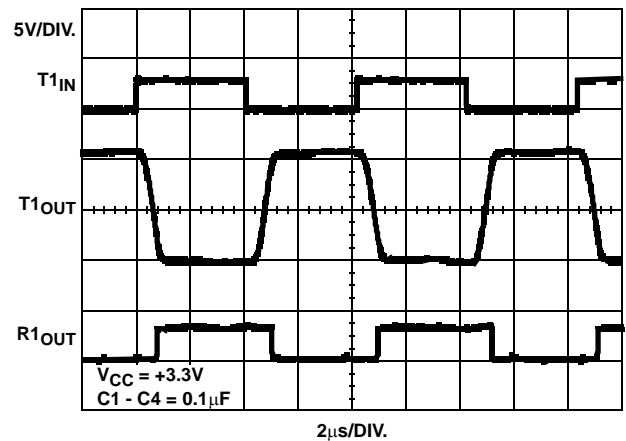

FIGURE 6. LOOPBACK TEST AT 250kbps

## Interconnection with 3V and 5V Logic

Standard 3.3V powered RS-232 devices interface well with 3V and 5V powered TTL compatible logic families (e.g., ACT and HCT), but the logic outputs (e.g.,  $R_{OUTS}$ ) fail to reach the  $V_{IH}$  level of 5V powered CMOS families like HC, AC, and CD4000. The ISL83386E  $V_L$  supply pin solves this problem. By connecting  $V_L$  to the same supply (1.8V to 5V) powering the logic device, the ISL83386E logic outputs will swing from GND to the logic  $V_{CC}$ .

## $\pm 15kV$ ESD Protection

All pins on the 3V interface devices include ESD protection structures, but the ISL83386E incorporates advanced structures which allow the RS-232 pins (transmitter outputs and receiver inputs) to survive ESD events up to  $\pm 15kV$ . The RS-232 pins are particularly vulnerable to ESD damage because they typically connect to an exposed port on the exterior of the finished product. Simply touching the port pins, or connecting a cable, can cause an ESD event that might destroy unprotected ICs. These new ESD structures protect the device whether or not it is powered up, protect without allowing any latchup mechanism to activate, and don't interfere with RS-232 signals as large as  $\pm 25V$ .

## Human Body Model (HBM) Testing

As the name implies, this test method emulates the ESD event delivered to an IC during human handling. The tester delivers the charge through a 1.5k $\Omega$  current limiting resistor, making the test less severe than the IEC61000 test which utilizes a 330 $\Omega$  limiting resistor. The HBM method determines an IC's ability to withstand the ESD transients typically present during handling and manufacturing. Due to the random nature of these events, each pin is tested with

respect to all other pins. The RS-232 pins on "E" family devices can withstand HBM ESD events to  $\pm 15kV$ .

## IEC61000-4-2 Testing

The IEC61000 test method applies to finished equipment, rather than to an individual IC. Therefore, the pins most likely to suffer an ESD event are those that are exposed to the outside world (the RS-232 pins in this case), and the IC is tested in its typical application configuration (power applied) rather than testing each pin-to-pin combination. The lower current limiting resistor coupled with the larger charge storage capacitor yields a test that is much more severe than the HBM test. The extra ESD protection built into this device's RS-232 pins allows the design of equipment meeting level 4 criteria without the need for additional board level protection on the RS-232 port.

## AIR-GAP DISCHARGE TEST METHOD

For this test method, a charged probe tip moves toward the IC pin until the voltage arcs to it. The current waveform delivered to the IC pin depends on approach speed, humidity, temperature, etc., so it is difficult to obtain repeatable results. The "E" device RS-232 pins withstand  $\pm 15kV$  air-gap discharges.

## CONTACT DISCHARGE TEST METHOD

During the contact discharge test, the probe contacts the tested pin before the probe tip is energized, thereby eliminating the variables associated with the air-gap discharge. The result is a more repeatable and predictable test, but equipment limits prevent testing devices at voltages higher than  $\pm 8kV$ . All "E" family devices survive  $\pm 8kV$  contact discharges on the RS-232 pins.

## Typical Performance Curves $V_{CC} = 3.3V$ , $T_A = 25^\circ C$

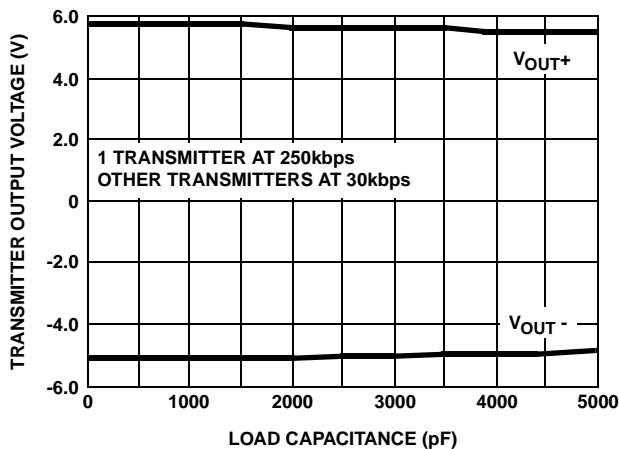

FIGURE 7. TRANSMITTER OUTPUT VOLTAGE vs LOAD CAPACITANCE

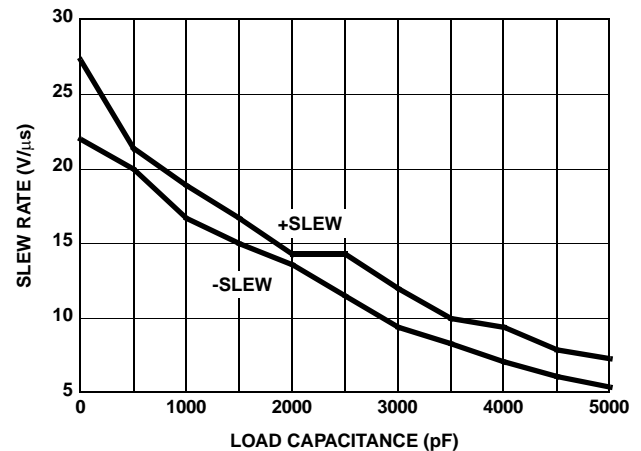

FIGURE 8. SLEW RATE vs LOAD CAPACITANCE

**Typical Performance Curves**  $V_{CC} = 3.3V, T_A = 25^\circ C$  (Continued)

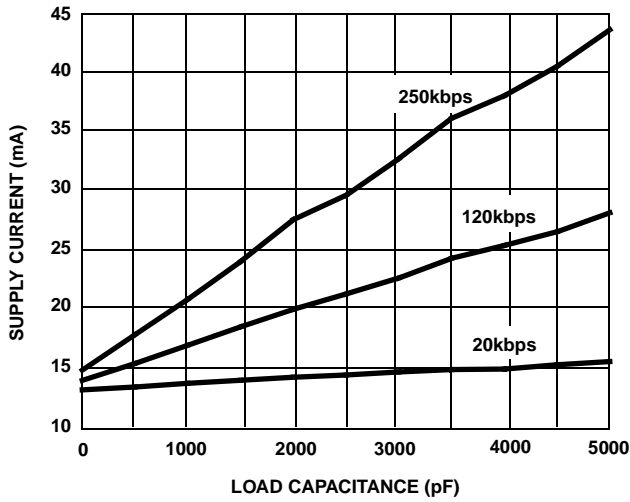

FIGURE 9. SUPPLY CURRENT vs LOAD CAPACITANCE WHEN TRANSMITTING DATA

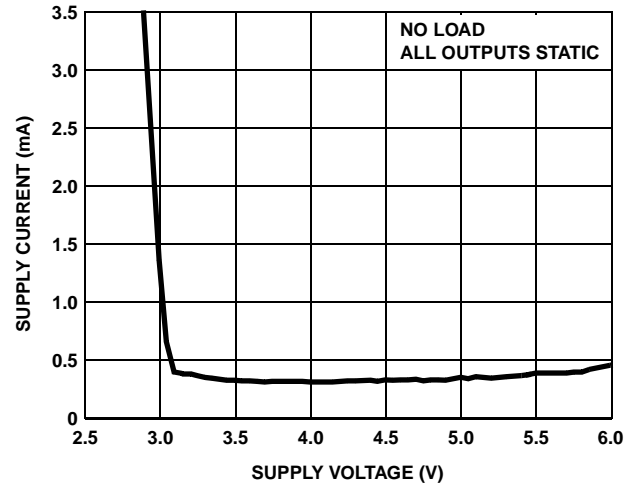

FIGURE 10. SUPPLY CURRENT vs SUPPLY VOLTAGE

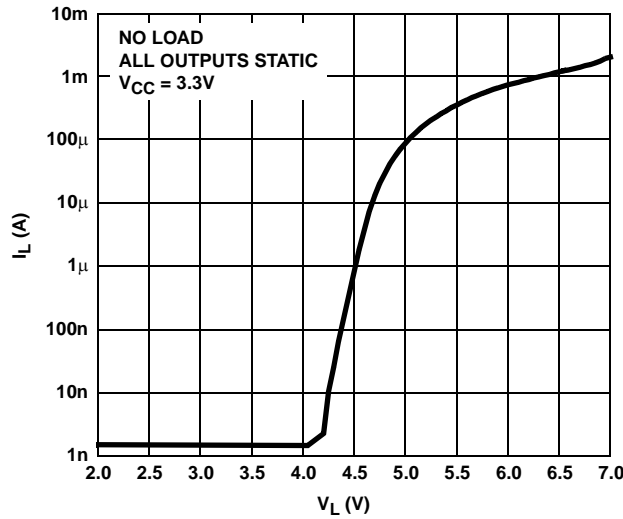

FIGURE 11.  $V_L$  SUPPLY CURRENT vs  $V_L$  VOLTAGE

**Die Characteristics**

SUBSTRATE POTENTIAL (POWERED UP)

GND

TRANSISTOR COUNT

422

PROCESS

Si Gate CMOS

Thin Shrink Small Outline Plastic Packages (TSSOP)

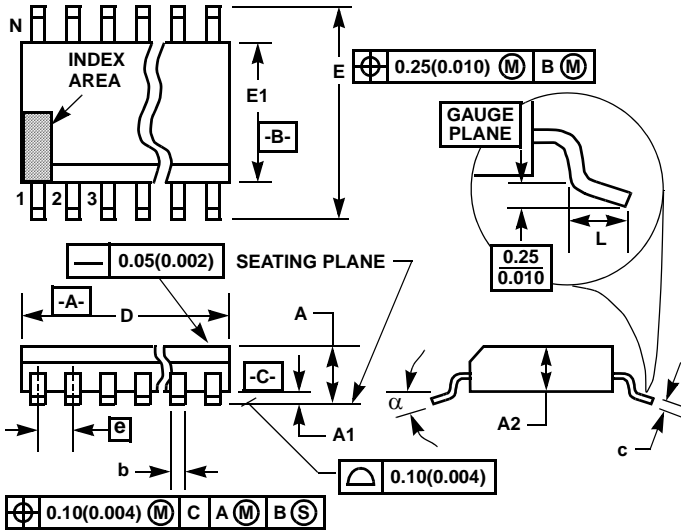

**M20.173**  
20 LEAD THIN SHRINK SMALL OUTLINE PLASTIC PACKAGE

SYMBOL	INCHES		MILLIMETERS		NOTES
	MIN	MAX	MIN	MAX	
A	-	0.047	-	1.20	-
A1	0.002	0.006	0.05	0.15	-
A2	0.031	0.051	0.80	1.05	-
b	0.0075	0.0118	0.19	0.30	9
c	0.0035	0.0079	0.09	0.20	-
D	0.252	0.260	6.40	6.60	3
E1	0.169	0.177	4.30	4.50	4
e	0.026 BSC		0.65 BSC		-
E	0.246	0.256	6.25	6.50	-
L	0.0177	0.0295	0.45	0.75	6
N	20		20		7
$\alpha$	0°	8°	0°	8°	-

NOTES:

1. These package dimensions are within allowable dimensions of JEDEC MO-153-AC, Issue E.
2. Dimensioning and tolerancing per ANSI Y14.5M-1982.
3. Dimension "D" does not include mold flash, protrusions or gate burrs. Mold flash, protrusion and gate burrs shall not exceed 0.15mm (0.006 inch) per side.
4. Dimension "E1" does not include interlead flash or protrusions. Interlead flash and protrusions shall not exceed 0.15mm (0.006 inch) per side.
5. The chamfer on the body is optional. If it is not present, a visual index feature must be located within the crosshatched area.
6. "L" is the length of terminal for soldering to a substrate.
7. "N" is the number of terminal positions.
8. Terminal numbers are shown for reference only.
9. Dimension "b" does not include dambar protrusion. Allowable dambar protrusion shall be 0.08mm (0.003 inch) total in excess of "b" dimension at maximum material condition. Minimum space between protrusion and adjacent lead is 0.07mm (0.0027 inch).
10. Controlling dimension: MILLIMETER. Converted inch dimensions are not necessarily exact. (Angles in degrees)

Rev. 1 6/98

All Intersil U.S. products are manufactured, assembled and tested utilizing ISO9000 quality systems. Intersil Corporation's quality certifications can be viewed at [www.intersil.com/design/quality](http://www.intersil.com/design/quality)

*Intersil products are sold by description only. Intersil Corporation reserves the right to make changes in circuit design, software and/or specifications at any time without notice. Accordingly, the reader is cautioned to verify that data sheets are current before placing orders. Information furnished by Intersil is believed to be accurate and reliable. However, no responsibility is assumed by Intersil or its subsidiaries for its use; nor for any infringements of patents or other rights of third parties which may result from its use. No license is granted by implication or otherwise under any patent or patent rights of Intersil or its subsidiaries.*

For information regarding Intersil Corporation and its products, see [www.intersil.com](http://www.intersil.com)

This datasheet has been downloaded from:

[www.DatasheetCatalog.com](http://www.DatasheetCatalog.com)

Datasheets for electronic components.



LittleDiode supplies new, hard to find or obsolete electronic components and semiconductors all over the world.

With over two million different components listed you are sure to find the part you need.

Feel free to visit us today at our online store:

[LittleDiode.com](http://LittleDiode.com)

Looking forward to providing you with the best possible service.