

## Low-Voltage, Single and Dual Supply, 8 to 1 Multiplexer, Dual 4 to 1 Multiplexer and a Triple SPDT Analog Switches

The Intersil ISL84051, ISL84052, ISL84053 devices are precision, bidirectional, analog switches configured as a 8 channel multiplexer/demultiplexer (ISL84051), a dual differential 4 channel multiplexer/demultiplexer (ISL84052) and a triple single pole/double throw (SPDT) switch (ISL84053) designed to operate from a single +2V to +12V supply or from a ±2V to ±6V supply. All devices have an inhibit pin to simultaneously open all signal paths.

ON resistance is 60Ω with a ±5V supply and 125Ω with a single +5V supply. Each switch can handle rail to rail analog signals. The off-leakage current is only 0.1nA at +25°C or 5nA at +85°C with a ±5V supply.

All digital inputs have 0.8V to 2.4V logic thresholds, ensuring TTL/CMOS logic compatibility when using a single +3.3V and +5V supply or dual ±5V supplies.

The ISL84051 is a 8 to 1 multiplexer device. The ISL84052 is a dual 4 to 1 multiplexer device. The ISL84053 is a committed triple SPDT, which is perfect for use in 2-to-1 multiplexer applications.

Table 1 summarizes the performance of this family.

**TABLE 1. FEATURES AT A GLANCE**

	ISL84051	ISL84052	ISL84053
CONFIGURATION	8:1 Mux	DUAL 4:1 Mux	TRIPLE SPDT
±5V R <sub>ON</sub>	60Ω	60Ω	60Ω
±5V t <sub>ON</sub> /t <sub>OFF</sub>	50ns/40ns	50ns/40ns	50ns/40ns
5V R <sub>ON</sub>	125Ω	125Ω	125Ω
5V t <sub>ON</sub> /t <sub>OFF</sub>	90ns/60ns	90ns/60ns	90ns/60ns
3V R <sub>ON</sub>	250Ω	250Ω	250Ω
3V t <sub>ON</sub> /t <sub>OFF</sub>	180ns/100ns	180ns/100ns	180ns/100ns
Packages	16 Ld SOIC, 16 Ld SSOP		

### Related Literature

- Technical Brief TB363 “Guidelines for Handling and Processing Moisture Sensitive Surface Mount Devices (SMDs)”
- Application Note AN557 “Recommended Test Procedures for Analog Switches”

### Features

- Drop-in Replacements for MAX4051/A, MAX4052/A and MAX4053/A
- Pin Compatible with MAX4581, MAX4582, MAX4583 and with Industry Standard 74HC4051, 74HC4052 and 74HC4053
- ON Resistance (R<sub>ON</sub>) Max, V<sub>S</sub> = ±5V ..... 100Ω
- ON Resistance (R<sub>ON</sub>) Max, V<sub>S</sub> = +3V ..... 525Ω
- R<sub>ON</sub> Matching Between Channels ..... <6Ω
- Low Charge Injection ..... 10pC (Max)
- Single Supply Operation ..... +2V to +12V
- Dual Supply Operation ..... ±2V to ±6
- Fast Switching Action (V<sub>S</sub> = +5V)
  - t<sub>ON</sub> ..... 90ns
  - t<sub>OFF</sub> ..... 60ns
- Guaranteed Max Off-leakage @ V<sub>S</sub> = ±5V ..... 5nA
- Guaranteed Break-Before-Make
- TTL, CMOS Compatible

### Applications

- Portable Equipment
- Communications Systems
  - Radios
  - Telecom Infrastructure
  - ADSL, VDSL Modems
- Test Equipment
  - Medical Ultrasound
  - Magnetic Resonance Image
  - CT and PET Scanners (MRI)
  - ATE
  - Electrocardiograph
- Audio and Video Signal Routing
- Various Circuits
  - +3V/+5V DACs and ADCs
  - Sample and Hold Circuits
  - Operational Amplifier Gain Switching Networks
  - High Frequency Analog Switching
  - High Speed Multiplexing
  - Integrator Reset Circuits

Pinouts

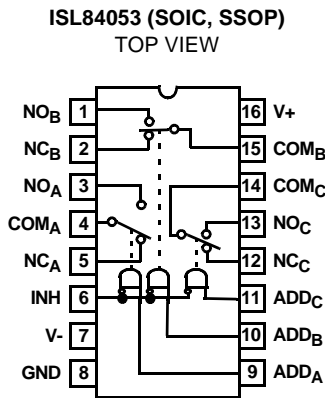
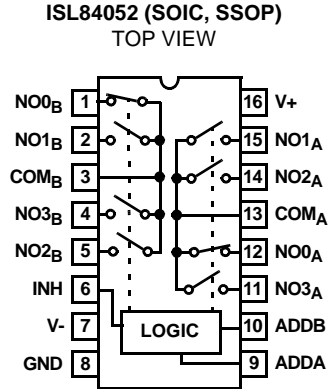
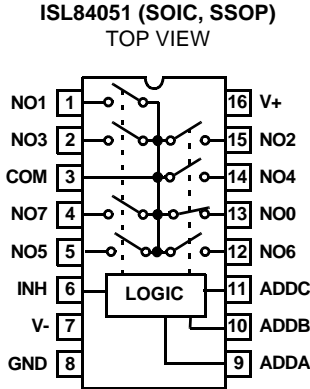

NOTE:

1. Switches Shown for Logic "0" Inputs.

Ordering Information

PART NO.	TEMP. RANGE (°C)	PACKAGE	PKG. DWG. #
ISL84051IB	-40 to 85	16 Ld SOIC	M16.15
ISL84051IA	-40 to 85	16 Ld SSOP	M16.15A
ISL84052IB	-40 to 85	16 Ld SOIC	M16.15
ISL84052IA	-40 to 85	16 Ld SSOP	M16.15A
ISL84053IB	-40 to 85	16 Ld SOIC	M16.15
ISL84053IA	-40 to 85	16 Ld SSOP	M16.15A

NOTE: Most surface mount devices are available on tape and reel; add "-T" to suffix.

Pin Description

PIN	FUNCTION
V+	Positive Power Supply Input
V-	Negative Power Supply Input. Connect to GND for Single Supply Configurations.
GND	Ground Connection
INH	Digital Control Input. Connect to GND for Normal Operation. Connect to V+ to turn all switches off.
COM	Analog Switch Common Pin
NO	Analog Switch Normally Open Pin
NC	Analog Switch Normally Closed Pin
ADD	Address Input Pin

**Truth Tables**

ISL84051

INH	ADDC	ADDB	ADDA	SWITCH ON
1	X	X	X	None
0	0	0	0	NO0
0	0	0	1	NO1
0	0	1	0	NO2
0	0	1	1	NO3
0	1	0	0	NO4
0	1	0	1	NO5
0	1	1	0	NO6
0	1	1	1	NO7

ISL84052

INH	ADDB	ADDA	SWITCH ON
1	X	X	None
0	0	0	NO0
0	0	1	NO1
0	1	0	NO2
0	1	1	NO3

ISL84053

INH	ADDC	ADDB	ADDA	SWITCH ON
1	X	X	X	None
0	X	X	0	NC <sub>A</sub>
0	X	X	1	NO <sub>A</sub>
0	X	0	X	NC <sub>B</sub>
0	X	1	X	NO <sub>B</sub>
0	0	X	X	NC <sub>C</sub>
0	1	X	X	NO <sub>C</sub>

NOTE: Logic "0"  $\leq 0.8V$ . Logic "1"  $\geq 2.4V$ , with V+ between 2.7V and 10V. X = Don't Care.

# ISL84051, ISL84052, ISL84053

## Absolute Maximum Ratings

V+ to V-	-0.3 to 15V
V+ to GND	-0.3 to 15V
V- to GND	-15 to 0.3V
Input Voltages	
INH, NO, NC, ADD (Note 2)	((V-)-0.3) to ((V+) + 0.3V)
Output Voltages	
COM (Note 2)	((V-)-0.3) to ((V+) + 0.3V)
Continuous Current (Any Terminal)	±30mA
Peak Current NO, NC, or COM	
(Pulsed 1ms, 10% Duty Cycle, Max)	±100mA
ESD Rating	
HBM (Per MIL-STD-883, Method 3015.7)	>2kV

## Thermal Information

Thermal Resistance (Typical, Note 3)	$\theta_{JA}$ (°C/W)
16 Ld SOIC Package	115
16 Ld SSOP Package	160
Maximum Junction Temperature (Plastic Package)	150°C
Maximum Storage Temperature Range	-65°C to 150°C
Maximum Lead Temperature (Soldering 10s)	300°C
(Lead Tips Only)	

## Operating Conditions

Temperature Range	
ISL8405XIX	-40°C to 85°C

CAUTION: Stresses above those listed in "Absolute Maximum Ratings" may cause permanent damage to the device. This is a stress only rating and operation of the device at these or any other conditions above those indicated in the operational sections of this specification is not implied.

### NOTES:

- Signals on NC, NO, COM, ADD, or INH exceeding V+ or V- are clamped by internal diodes. Limit forward diode current to maximum current ratings.
- $\theta_{JA}$  is measured with the component mounted on a low effective thermal conductivity test board in free air. See Tech Brief TB379 for details.

**Electrical Specifications: ±5V Supply** Test Conditions:  $V_{SUPPLY} = \pm 4.5V$  to  $\pm 5.5V$ , GND = 0V,  $V_{INH} = 2.4V$ ,  $V_{INL} = 0.8V$  (Note 4), Unless Otherwise Specified

PARAMETER	TEST CONDITIONS	TEMP (°C)	(NOTE 5) MIN	TYP	(NOTE 5) MAX	UNITS
<b>ANALOG SWITCH CHARACTERISTICS</b>						
Analog Signal Range, $V_{ANALOG}$		Full	V-	-	V+	V
ON Resistance, $R_{ON}$	$V_S = \pm 5V$ , $I_{COM} = 1mA$ , $V_{NO}$ or $V_{NC} = \pm 3V$ , (See Figure 5)	25	-	60	100	$\Omega$
		Full	-	-	125	$\Omega$
$R_{ON}$ Matching Between Channels, $\Delta R_{ON}$	$V_S = \pm 5V$ , $I_{COM} = 1mA$ , $V_{NO}$ or $V_{NC} = \pm 3V$ , (Note 6)	25	-	-	6	$\Omega$
		Full	-	-	12	$\Omega$
$R_{ON}$ Flatness, $R_{FLAT(ON)}$	$V_S = \pm 5V$ , $I_{COM} = 1mA$ , $V_{NO}$ or $V_{NC} = \pm 3V$ , 0V, (Note 7)	25	-	-	10	$\Omega$
		Full	-	-	15	$\Omega$
NO or NC OFF Leakage Current, $I_{NO(OFF)}$ or $I_{NC(OFF)}$	$V_S = \pm 5.5V$ , $V_{COM} = \pm 4.5V$ , $V_{NO}$ or $V_{NC} = \mp 4.5V$ , (Note 8)	25	-0.1	0.002	0.1	nA
		Full	-5	-	5	nA
COM OFF Leakage Current, $I_{COM(OFF)}$ , (ISL84051)	$V_S = \pm 5.5V$ , $V_{COM} = \pm 4.5V$ , $V_{NO}$ or $V_{NC} = \mp 4.5V$ , (Note 8)	25	-0.1	0.002	0.1	nA
		Full	-5	-	5	nA
COM OFF Leakage Current, $I_{COM(OFF)}$ , (ISL84052, ISL84053)	$V_S = \pm 5.5V$ , $V_{COM} = \pm 4.5V$ , $V_{NO}$ or $V_{NC} = \mp 4.5V$ , (Note 8)	25	-0.1	0.002	0.1	nA
		Full	-2.5	-	2.5	nA
COM ON Leakage Current, $I_{COM(ON)}$ , (ISL84051)	$V_S = \pm 5.5V$ , $V_{COM} = V_{NO}$ or $V_{NC} = \pm 4.5V$ , (Note 8)	25	-0.1	0.002	0.1	nA
		Full	-5	-	5	nA
COM ON Leakage Current, $I_{COM(ON)}$ , (ISL84052, ISL84053)	$V_S = \pm 5.5V$ , $V_{COM} = V_{NO}$ or $V_{NC} = \pm 4.5V$ , (Note 8)	25	-0.1	0.002	0.1	nA
		Full	-2.5	-	2.5	nA
<b>DIGITAL INPUT CHARACTERISTICS</b>						
Input Voltage High, $V_{INH}$ , $V_{ADDH}$		Full	2.4	-	-	V
Input Voltage Low, $V_{INL}$ , $V_{ADDL}$		Full	-	-	0.8	V
Input Current, $I_{INH}$ , $I_{INL}$ , $I_{ADDH}$ , $I_{ADDL}$	$V_S = \pm 5.5V$ , $V_{INH}$ , $V_{ADD} = 0V$ or $V+$	Full	-1	0.03	1	$\mu A$

## ISL84051, ISL84052, ISL84053

**Electrical Specifications: ±5V Supply** Test Conditions:  $V_{SUPPLY} = \pm 4.5V$  to  $\pm 5.5V$ ,  $GND = 0V$ ,  $V_{INH} = 2.4V$ ,  $V_{INL} = 0.8V$  (Note 4), Unless Otherwise Specified **(Continued)**

PARAMETER	TEST CONDITIONS	TEMP (°C)	(NOTE 5) MIN	TYP	(NOTE 5) MAX	UNITS	
<b>DYNAMIC CHARACTERISTICS</b>							
Inhibit Turn-ON Time, $t_{ON}$	$V_S = \pm 4.5V$ , $V_{NO}$ or $V_{NC} = \pm 3V$ , $R_L = 300\Omega$ , $C_L = 35pF$ , $V_{IN} = 0$ to 3, (See Figure 1)	25	-	50	175	ns	
		Full	-	-	225	ns	
Inhibit Turn-OFF Time, $t_{OFF}$	$V_S = \pm 4.5V$ , $V_{NO}$ or $V_{NC} = \pm 3V$ , $R_L = 300\Omega$ , $C_L = 35pF$ , $V_{IN} = 0$ to 3, (See Figure 1)	25	-	40	150	ns	
		Full	-	-	200	ns	
Address Transition Time, $t_{TRANS}$	$V_S = \pm 4.5V$ , $V_{NO}$ or $V_{NC} = \pm 3V$ , $R_L = 300\Omega$ , $C_L = 35pF$ , $V_{IN} = 0$ to 3, (See Figure 1)	25	-	75	250	ns	
Break-Before-Make Time, $t_{BBM}$	$V_S = \pm 5.5V$ , $V_{NO}$ or $V_{NC} = 3V$ , $R_L = 300\Omega$ , $C_L = 35pF$ , $V_{IN} = 0$ to 3V, (See Figure 3)	25	2	10	-	ns	
Charge Injection, Q	$C_L = 1.0nF$ , $V_G = 0V$ , $R_G = 0\Omega$ , (See Figure 2)	25	-	2	10	pC	
NO/NC OFF Capacitance, $C_{OFF}$	$f = 1MHz$ , $V_{NO}$ or $V_{NC} = V_{COM} = 0V$ , (See Figure 7)	25	-	3	-	pF	
COM OFF Capacitance, $C_{OFF}$	$f = 1MHz$ , $V_{NO}$ or $V_{NC} = V_{COM} = 0V$ , (See Figure 7)	ISL84051	25	-	21	-	pF
		ISL84052	25	-	12	-	pF
		ISL84053	25	-	9	-	pF
COM ON Capacitance, $C_{COM(ON)}$	$f = 1MHz$ , $V_{NO}$ or $V_{NC} = V_{COM} = 0V$ , (See Figure 7)	ISL84051	25	-	26	-	pF
		ISL84052	25	-	18	-	pF
		ISL84053	25	-	14	-	pF
OFF Isolation	$R_L = 50\Omega$ , $C_L = 15pF$ , $f = 100kHz$ , $V_{NO}$ or $V_{NC} = 1V_{RMS}$ , (See Figures 4 and 6)	25	-	<90	-	dB	
Crosstalk, (Note 9) (ISL84052, ISL84053 only)		25	-	<-90	-	dB	
<b>POWER SUPPLY CHARACTERISTICS</b>							
Power Supply Range		Full	±2	-	±6	V	
Positive Supply Current, $I_+$	$V_S = \pm 5.5V$ , $V_{INH}$ , $V_{ADD} = 0V$ or $V_+$ , Switch On or Off	25	-1	0.1	1	μA	
		Full	-10	-	10	μA	
Negative Supply Current, $I_-$		25	-1	0.1	1	μA	
		Full	-10	-	10	μA	

**NOTES:**

4.  $V_{IN}$  = Input voltage to perform proper function.
5. The algebraic convention, whereby the most negative value is a minimum and the most positive a maximum, is used in this data sheet.
6.  $\Delta R_{ON} = R_{ON} (MAX) - R_{ON} (MIN)$ .
7. Flatness is defined as the difference between maximum and minimum value of on-resistance over the specified analog signal range.
8. Leakage parameter is 100% tested at high temp, and guaranteed by correlation at 25°C.
9. Between any two switches.

## ISL84051, ISL84052, ISL84053

### Electrical Specifications: 5V Supply

Test Conditions:  $V_+ = +4.5V$  to  $+5.5V$ ,  $V_- = GND = 0V$ ,  $V_{INH} = 2.4V$ ,  $V_{INL} = 0.8V$  (Note 4), Unless Otherwise Specified

PARAMETER	TEST CONDITIONS	TEMP (°C)	MIN (NOTE 5)	TYP	MAX (NOTE 5)	UNITS
<b>ANALOG SWITCH CHARACTERISTICS</b>						
Analog Signal Range, $V_{ANALOG}$		Full	0	-	$V_+$	V
ON Resistance, $R_{ON}$	$V_+ = 5V$ , $I_{COM} = 1.0mA$ , $V_{NO}$ or $V_{NC} = 3.5V$ , (See Figure 5)	25	-	125	225	$\Omega$
		Full	-	-	280	$\Omega$
NO or NC OFF Leakage Current, $I_{NO(OFF)}$ or $I_{NC(OFF)}$	$V_+ = 5.5V$ , $V_{COM} = 0V$ , $4.5V$ , $V_{NO}$ or $V_{NC} = 4.5V$ , $0V$ , (Note 8)	25	-1	0.002	1	nA
		Full	-10	-	10	nA
COM OFF Leakage Current, $I_{COM(OFF)}$ , (ISL84051)	$V_+ = 5.5V$ , $V_{COM} = 0V$ , $4.5V$ , $V_{NO}$ or $V_{NC} = 4.5V$ , $0V$ , (Note 8)	25	-1	0.002	1	nA
		Full	-10	-	10	nA
COM OFF Leakage Current, $I_{COM(OFF)}$ , (ISL84052, ISL84053)	$V_+ = 5.5V$ , $V_{COM} = 0V$ , $4.5V$ , $V_{NO}$ or $V_{NC} = 4.5V$ , $0V$ , (Note 8)	25	-1	0.002	1	nA
		Full	-5	-	5	nA
COM ON Leakage Current, $I_{COM(ON)}$	$V_+ = 5.5V$ , $V_{COM} = V_{NO}$ or $V_{NC} = 4.5V$ , (Note 8)	25	-1	0.002	1	nA
		Full	-10	-	10	nA
<b>DIGITAL INPUT CHARACTERISTICS</b>						
Input Voltage High, $V_{INH}$ , $V_{ADDH}$		Full	2.4	-	-	V
Input Voltage Low, $V_{INL}$ , $V_{ADDL}$		Full	-	-	0.8	V
Input Current, $I_{INH}$ , $I_{INL}$ , $I_{ADDH}$ , $I_{ADDL}$	$V_+ = 5.5V$ , $V_{INH}$ , $V_{ADD} = 0V$ or $V_+$	Full	-1	0.03	1	$\mu A$
<b>DYNAMIC CHARACTERISTICS</b>						
Inhibit Turn-ON Time, $t_{ON}$	$V_+ = 4.5V$ , $V_{NO}$ or $V_{NC} = 3V$ , $R_L = 300\Omega$ , $C_L = 35pF$ , $V_{IN} = 0$ to $3V$ , (See Figure 1)	25	-	90	200	ns
		Full	-	-	275	ns
Inhibit Turn-OFF Time, $t_{OFF}$	$V_+ = 4.5V$ , $V_{NO}$ or $V_{NC} = 3V$ , $R_L = 300\Omega$ , $C_L = 35pF$ , $V_{IN} = 0$ to $3V$ , (See Figure 1)	25	-	60	125	ns
		Full	-	-	175	ns
Break-Before-Make Time, $t_{BBM}$	$V_+ = 5.5V$ , $V_{NO}$ or $V_{NC} = 3V$ , $R_L = 300\Omega$ , $C_L = 35pF$ , $V_{IN} = 0$ to $3V$ , (See Figure 3)	25	-	30	-	ns
Charge Injection, Q	$C_L = 1.0nF$ , $V_G = 0V$ , $R_G = 0\Omega$ , (See Figure 2)	25	-	2	10	pC
OFF Isolation	$R_L = 50\Omega$ , $C_L = 15pF$ , $f = 100kHz$ , $V_{NO}$ or $V_{NC} = 1V_{RMS}$ , (See Figures 4 and 6)	25	-	<90	-	dB
Crosstalk, (Note 9) (ISL84052, ISL840533 only)		25	-	<-90	-	dB
<b>POWER SUPPLY CHARACTERISTICS</b>						
Power Supply Range		Full	2	-	12	V
Positive Supply Current, $I_+$	$V_+ = 5.5V$ , $V_- = 0V$ , $V_{INH}$ , $V_{ADD} = 0V$ or $V_+$ , Switch On or Off	25	-1	-	1	$\mu A$
		Full	-10	-	10	$\mu A$

# ISL84051, ISL84052, ISL84053

## Electrical Specifications: 3.3V Supply

Test Conditions:  $V_+ = +3.0V$  to  $+3.6V$ ,  $V_- = GND = 0V$ ,  $V_{INH} = 2.4V$ ,  $V_{INL} = 0.8V$  (Note 4), Unless Otherwise Specified

PARAMETER	TEST CONDITIONS	TEMP (°C)	MIN (NOTE 5)	TYP	MAX (NOTE 5)	UNITS
<b>ANALOG SWITCH CHARACTERISTICS</b>						
Analog Signal Range, $V_{ANALOG}$		Full	0	-	$V_+$	V
ON Resistance, $R_{ON}$	$V_+ = 3V$ , $I_{COM} = 1.0mA$ , $V_{NO}$ or $V_{NC} = 1.5V$	25	-	250	525	$\Omega$
		Full	-	-	700	$\Omega$
NO or NC OFF Leakage Current, $I_{NO(OFF)}$ or $I_{NC(OFF)}$	$V_+ = 3.6V$ , $V_{COM} = 0V$ , $3V$ , $V_{NO}$ or $V_{NC} = 3V$ , $0V$ , (Note 8)	25	-1	0.002	1	nA
		Full	-10	-	10	nA
COM OFF Leakage Current, $I_{COM(OFF)}$ , (ISL84051)	$V_+ = 3.6V$ , $V_{COM} = 0V$ , $3V$ , $V_{NO}$ or $V_{NC} = 3V$ , $0V$ , (Note 8)	25	-1	0.002	1	nA
		Full	-10	-	10	nA
COM OFF Leakage Current, $I_{COM(OFF)}$ , (ISL84052, ISL84053)	$V_+ = 3.6V$ , $V_{COM} = 0V$ , $3V$ , $V_{NO}$ or $V_{NC} = 3V$ , $0V$ , (Note 8)	25	-1	0.002	1	nA
		Full	-5	-	5	nA
COM ON Leakage Current, $I_{COM(ON)}$	$V_+ = 3.6V$ , $V_{COM} = V_{NO}$ or $V_{NC} = 3V$ , (Note 8)	25	-1	0.002	1	nA
		Full	-10	-	10	nA
<b>DIGITAL INPUT CHARACTERISTICS</b>						
Input Voltage High, $V_{INH}$ , $V_{ADDH}$		Full	2.4	-	-	V
Input Voltage Low, $V_{INL}$ , $V_{ADDL}$		Full	-	-	0.8	V
Input Current, $I_{INH}$ , $I_{INL}$ , $I_{ADDH}$ , $I_{ADDL}$	$V_+ = 3.6V$ , $V_{INH}$ , $V_{ADD} = 0V$ or $V_+$	Full	-1	0.03	1	$\mu A$
<b>DYNAMIC CHARACTERISTICS</b>						
Inhibit Turn-ON Time, $t_{ON}$	$V_+ = 3V$ , $V_{NO}$ or $V_{NC} = 1.5V$ , $R_L = 300\Omega$ , $C_L = 35pF$ , $V_{IN} = 0$ to $3V$ , (See Figure 1)	25	-	180	600	ns
		Full	-	-	700	ns
Inhibit Turn-OFF Time, $t_{OFF}$	$V_+ = 3V$ , $V_{NO}$ or $V_{NC} = 1.5V$ , $R_L = 300\Omega$ , $C_L = 35pF$ , $V_{IN} = 0$ to $3V$ , (See Figure 1)	25	-	100	300	ns
		Full	-	-	400	ns
Break-Before-Make Time, $t_{BBM}$	$V_+ = 3.6V$ , $V_{NO}$ or $V_{NC} = 1.5V$ , $R_L = 300\Omega$ , $C_L = 35pF$ , $V_{IN} = 0$ to $3V$ , (See Figure 3)	25	-	90	-	ns
Charge Injection, Q	$C_L = 1.0nF$ , $V_G = 0V$ , $R_G = 0\Omega$ , (See Figure 2)	25	-	1	10	pC
OFF Isolation	$R_L = 50\Omega$ , $C_L = 15pF$ , $f = 100kHz$ , $V_{NO}$ or $V_{NC} = 1V_{RMS}$ , (See Figures 4 and 6)	25	-	<90	-	dB
Crosstalk, (Note 9) (ISL84052, ISL84053 only)		25	-	<-90	-	dB
<b>POWER SUPPLY CHARACTERISTICS</b>						
Power Supply Range		Full	2	-	12	V
Positive Supply Current, $I_+$	$V_+ = 3.6V$ , $V_- = 0V$ , $V_{INH}$ , $V_{ADD} = 0V$ or $V_+$ , Switch On or Off	25	-1	-	1	$\mu A$
		Full	-10	-	10	$\mu A$

Test Circuits and Waveforms

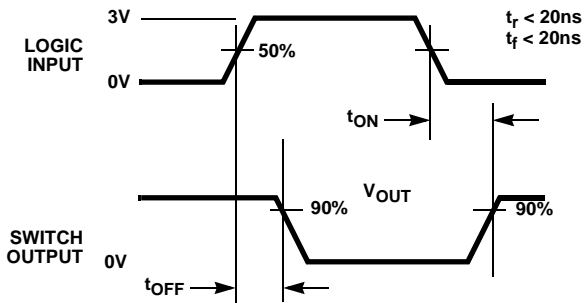

Logic input waveform is inverted for switches that have the opposite logic sense.

FIGURE 1A. INHIBIT  $t_{ON}/t_{OFF}$  MEASUREMENT POINTS

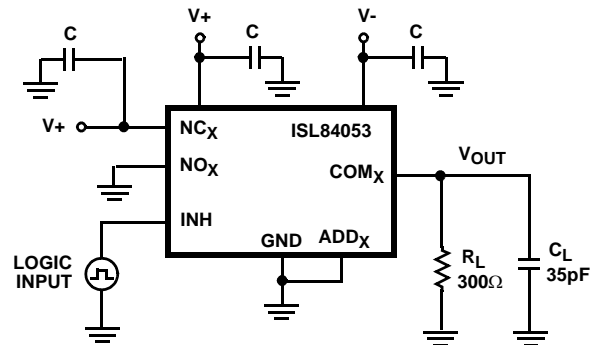
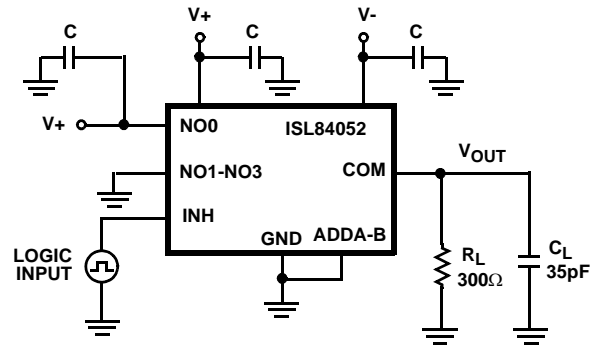
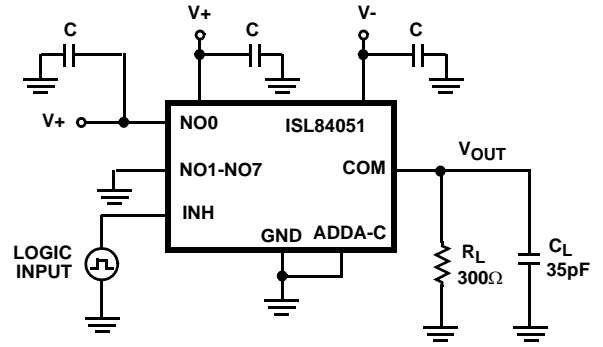

Repeat test for other switches.  $C_L$  includes fixture and stray capacitance.

$$V_{OUT} = V_{(NO \text{ or } NC)} \frac{R_L}{R_L + R_{(ON)}}$$

FIGURE 1B. INHIBIT  $t_{ON}/t_{OFF}$  TEST CIRCUIT

Test Circuits and Waveforms (Continued)

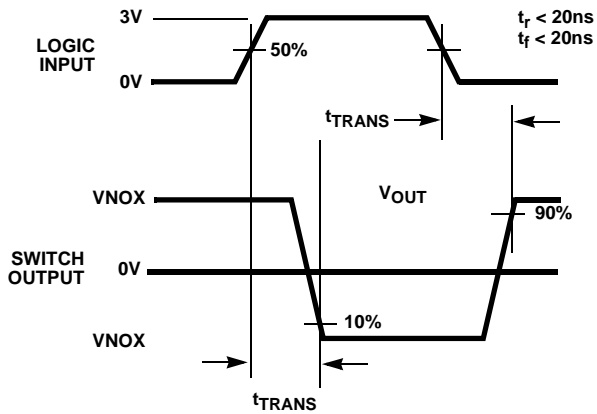

Logic input waveform is inverted for switches that have the opposite logic sense.

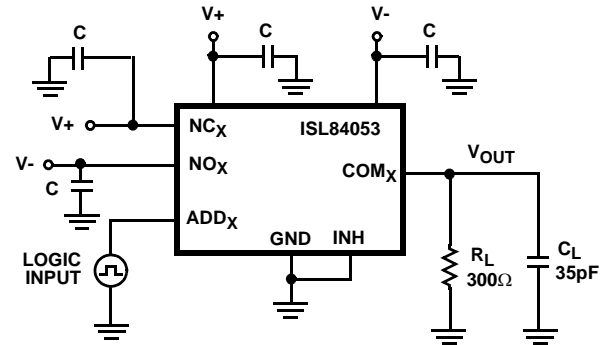
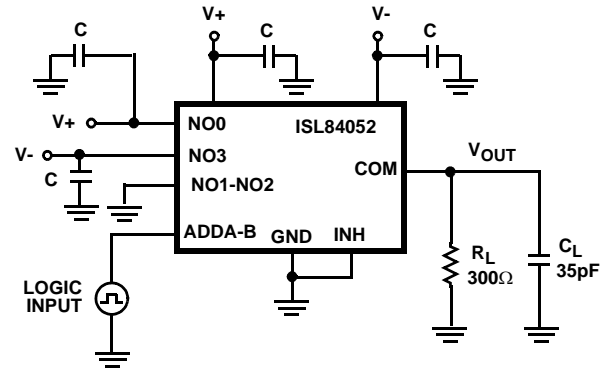
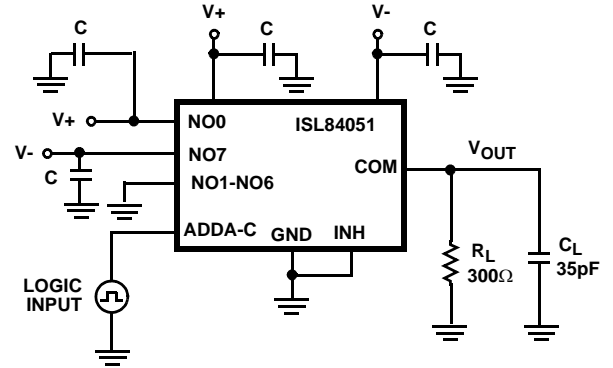

Repeat test for other switches. CL includes fixture and stray capacitance.

$$V_{OUT} = V_{(NO \text{ or } NC)} \frac{R_L}{R_L + R_{(ON)}}$$

FIGURE 1C. ADDRESS tTRANS MEASUREMENT POINTS

FIGURE 1D. ADDRESS tTRANS TEST CIRCUIT

FIGURE 1. SWITCHING TIMES (Continued)

Test Circuits and Waveforms (Continued)

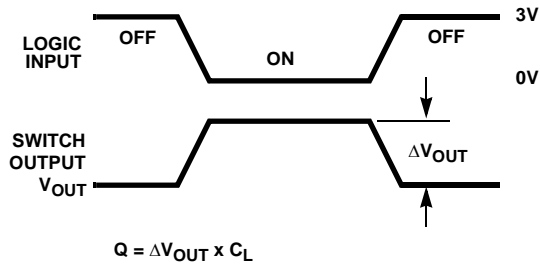

FIGURE 2A. Q MEASUREMENT POINTS

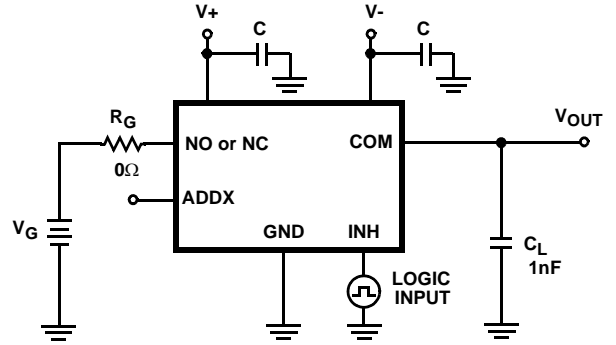

FIGURE 2B. Q TEST CIRCUIT

FIGURE 2. CHARGE INJECTION

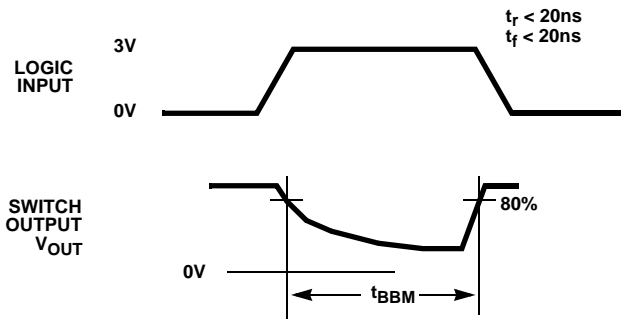

FIGURE 3A.  $t_{BBM}$  MEASUREMENT POINTS

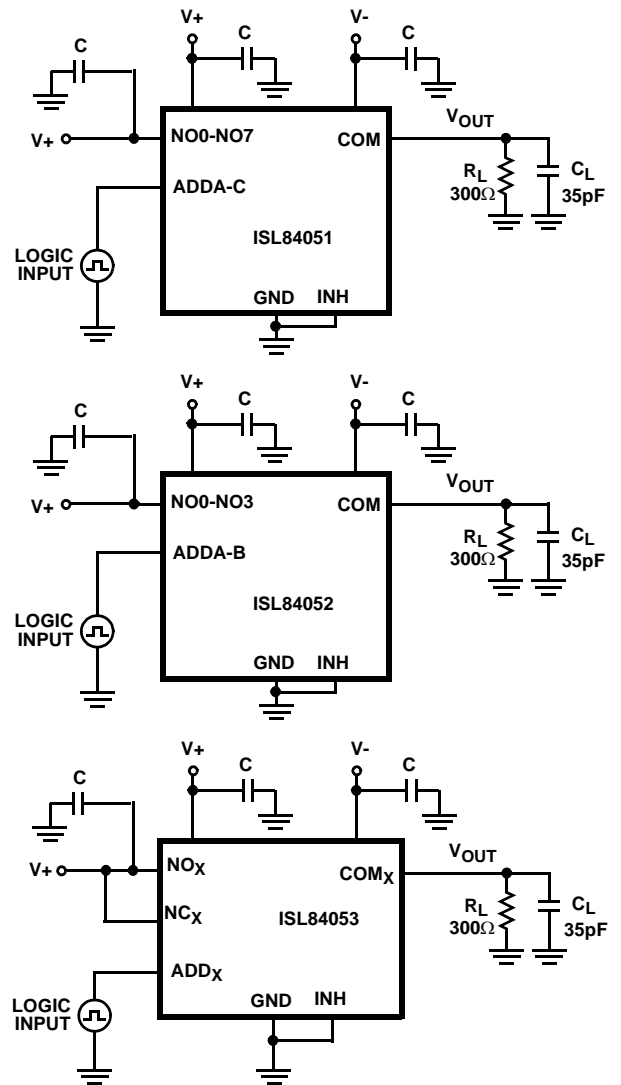

FIGURE 3B.  $t_{BBM}$  TEST CIRCUIT

FIGURE 3. BREAK-BEFORE-MAKE TIME

Test Circuits and Waveforms (Continued)

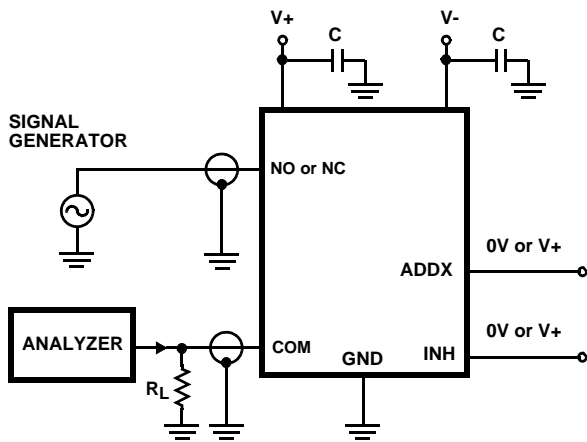

FIGURE 4. OFF ISOLATION TEST CIRCUIT

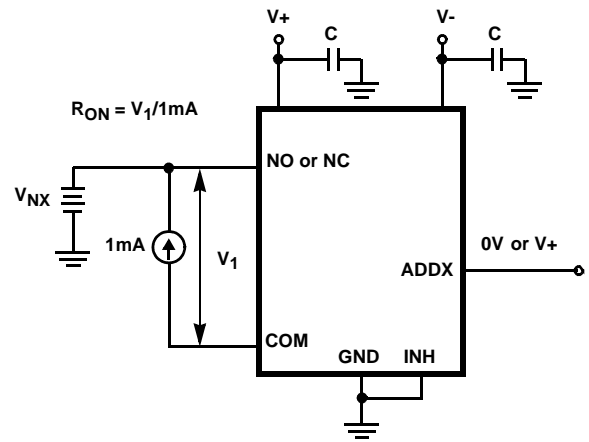

FIGURE 5.  $R_{ON}$  TEST CIRCUIT

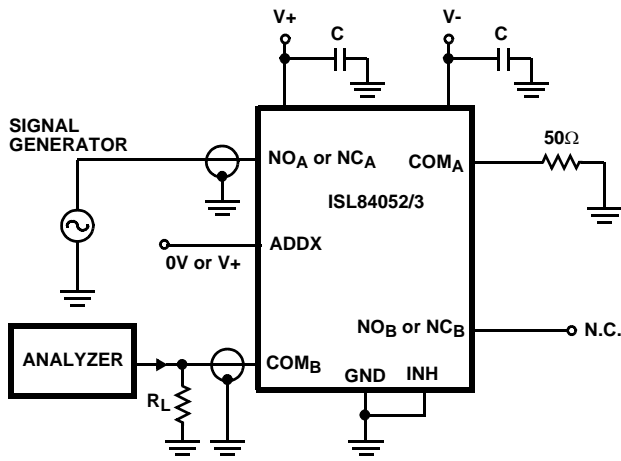

FIGURE 6. CROSSTALK TEST CIRCUIT

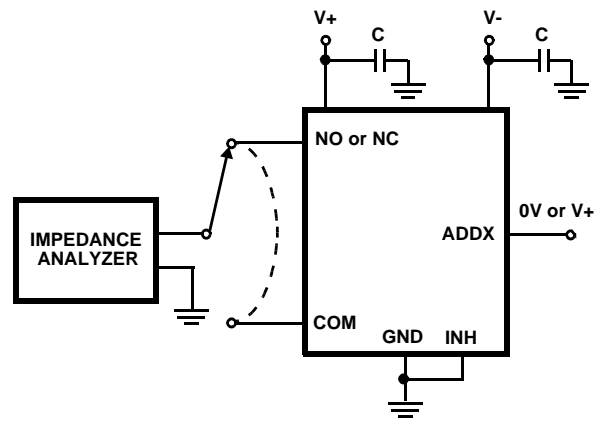

FIGURE 7. CAPACITANCE TEST CIRCUIT

## Detailed Description

The ISL84051, ISL84052, ISL84053 analog switches offer precise switching capability from a bipolar  $\pm 2V$  to  $\pm 6V$  or a single 2V to 12V supply with low on-resistance ( $60\Omega$ ) and high speed operation ( $t_{ON} = 50ns$ ,  $t_{OFF} = 40ns$ ). The devices are especially well suited to portable battery powered equipment thanks to the low operating supply voltage (2V), low power consumption ( $3\mu W$ ), low leakage currents (5nA max). High frequency applications also benefit from the wide bandwidth, and the very high off isolation and crosstalk rejection.

### Supply Sequencing And Overvoltage Protection

With any CMOS device, proper power supply sequencing is required to protect the device from excessive input currents which might permanently damage the IC. All I/O pins contain ESD protection diodes from the pin to  $V+$  and to  $V-$  (see Figure 8). To prevent forward biasing these diodes,  $V+$  and  $V-$  must be applied before any input signals, and input signal voltages must remain between  $V+$  and  $V-$ . If these conditions cannot be guaranteed, then one of the following two protection methods should be employed.

Logic inputs can easily be protected by adding a  $1k\Omega$  resistor in series with the input (see Figure 8). The resistor limits the input current below the threshold that produces permanent damage, and the sub-microamp input current produces an insignificant voltage drop during normal operation.

This method is not applicable for the signal path inputs. Adding a series resistor to the switch input defeats the purpose of using a low  $R_{ON}$  switch, so two small signal diodes can be added in series with the supply pins to provide overvoltage protection for all pins (see Figure 8). These additional diodes limit the analog signal from 1V below  $V+$  to 1V above  $V-$ . The low leakage current performance is unaffected by this approach, but the switch resistance may increase, especially at low supply voltages.

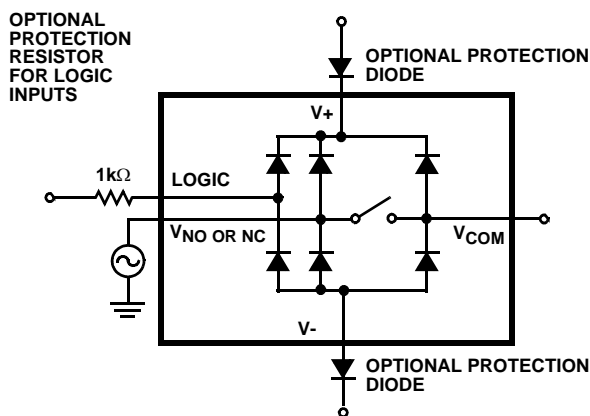

FIGURE 8. INPUT OVERVOLTAGE PROTECTION

## Power-Supply Considerations

The ISL8405X construction is typical of most CMOS analog switches, in that they have three supply pins:  $V+$ ,  $V-$ , and GND.  $V+$  and  $V-$  drive the internal CMOS switches and set their analog voltage limits, so there are no connections between the analog signal path and GND. Unlike switches with a 13V maximum supply voltage, the ISL8405X 15V maximum supply voltage provides plenty of room for the 10% tolerance of 12V supplies ( $\pm 6V$  or 12V single supply), as well as room for overshoot and noise spikes.

This family of switches performs equally well when operated with bipolar or single voltage supplies. The minimum recommended supply voltage is 2V or  $\pm 2V$ . It is important to note that the input signal range, switching times, and on-resistance degrade at lower supply voltages. Refer to the electrical specification tables and *Typical Performance* curves for details.

$V+$  and GND power the internal logic (thus setting the digital switching point) and level shifters. The level shifters convert the logic levels to switched  $V+$  and  $V-$  signals to drive the analog switch gate terminals.

### Logic-Level Thresholds

$V+$  and GND power the internal logic stages, so  $V-$  has no affect on logic thresholds. This switch family is TTL compatible (0.8V and 2.4V) over a  $V+$  supply range of 2.7V to 10V. At 12V the  $V_{IH}$  level is about 3.5V. This is still below the CMOS guaranteed high output minimum level of 4V, but noise margin is reduced. For best results with a 12V supply, use a logic family that provides a  $V_{OH}$  greater than 4V.

The digital input stages draw supply current whenever the digital input voltage is not at one of the supply rails. Driving the digital input signals from GND to  $V+$  with a fast transition time minimizes power dissipation.

### High-Frequency Performance

In  $50\Omega$  systems, signal response is reasonably flat even past 100MHz (see Figure 17). Figure 17 also illustrates that the frequency response is very consistent over varying analog signal levels.

An OFF switch acts like a capacitor and passes higher frequencies with less attenuation, resulting in signal feed through from a switch's input to its output. Off Isolation is the resistance to this feed through, while Crosstalk indicates the amount of feed through from one switch to another. Figure 18 details the high Off Isolation and Crosstalk rejection provided by this family. At 10MHz, Off Isolation is about 55dB in  $50\Omega$  systems, decreasing approximately 20dB per decade as frequency increases. Higher load impedances decrease Off Isolation and Crosstalk rejection due to the voltage divider action of the switch OFF impedance and the load impedance.

**Leakage Considerations**

Reverse ESD protection diodes are internally connected between each analog-signal pin and both V+ and V-. One of these diodes conducts if any analog signal exceeds V+ or V-.

Virtually all the analog leakage current comes from the ESD diodes to V+ or V-. Although the ESD diodes on a given signal pin are identical and therefore fairly well balanced, they are reverse biased differently. Each is biased by either

V+ or V- and the analog signal. This means their leakages will vary as the signal varies. The difference in the two diode leakages to the V+ and V- pins constitutes the analog-signal-path leakage current. All analog leakage current flows between each pin and one of the supply terminals, not to the other switch terminal. This is why both sides of a given switch can show leakage currents of the same or opposite polarity. There is no connection between the analog signal paths and GND.

**Typical Performance Curves**  $T_A = 25^\circ\text{C}$ , Unless Otherwise Specified

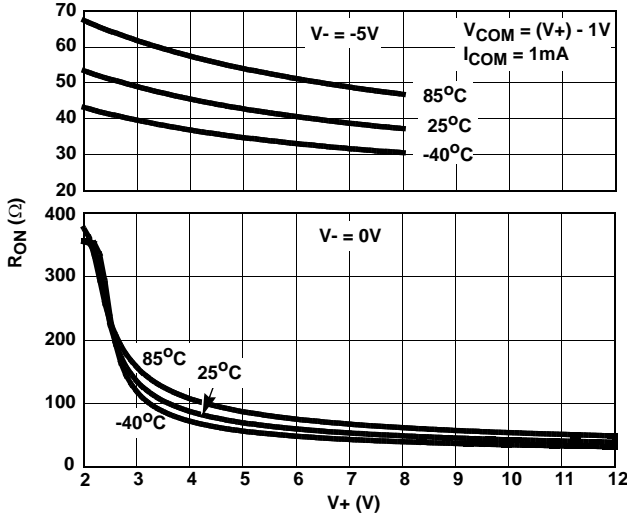

FIGURE 9. ON RESISTANCE vs SUPPLY VOLTAGE

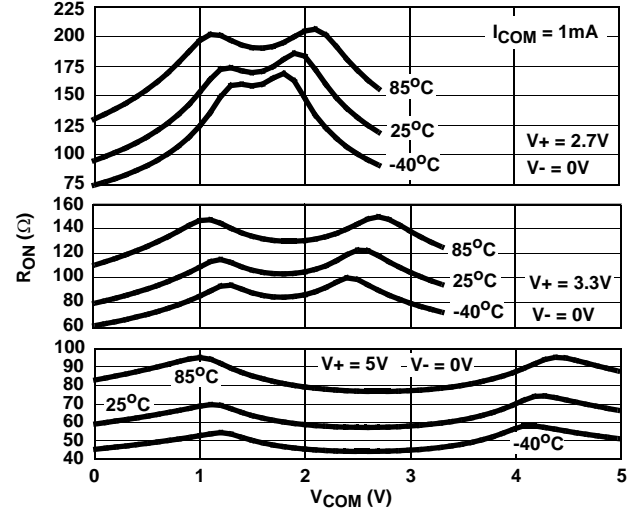

FIGURE 10. ON RESISTANCE vs SWITCH VOLTAGE

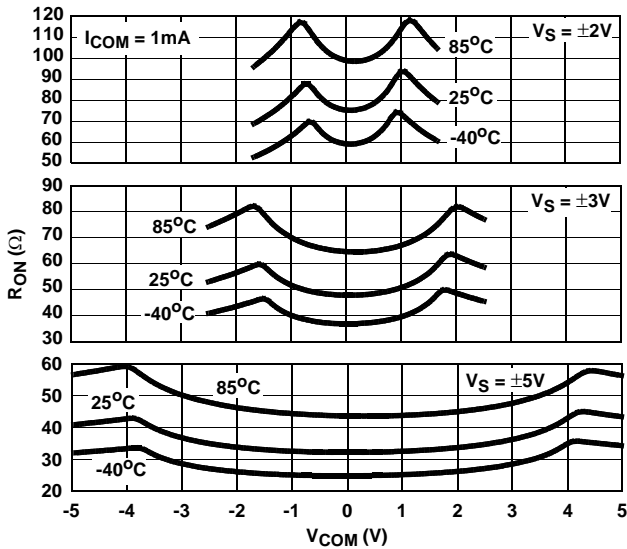

FIGURE 11. ON RESISTANCE vs SWITCH VOLTAGE

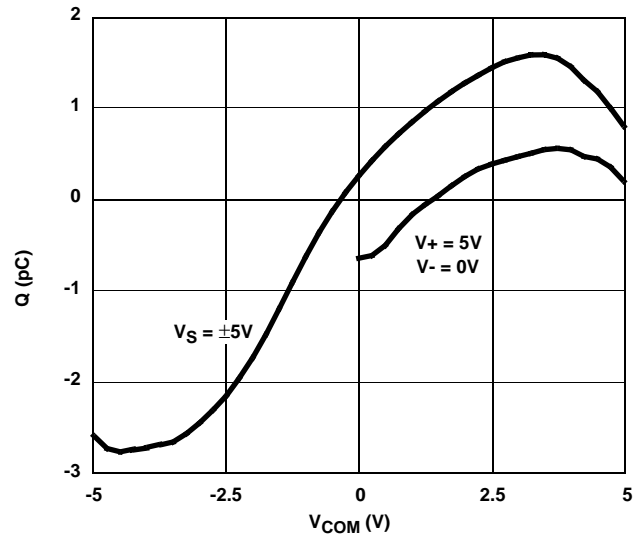

FIGURE 12. CHARGE INJECTION vs SWITCH VOLTAGE

Typical Performance Curves  $T_A = 25^\circ\text{C}$ , Unless Otherwise Specified (Continued)

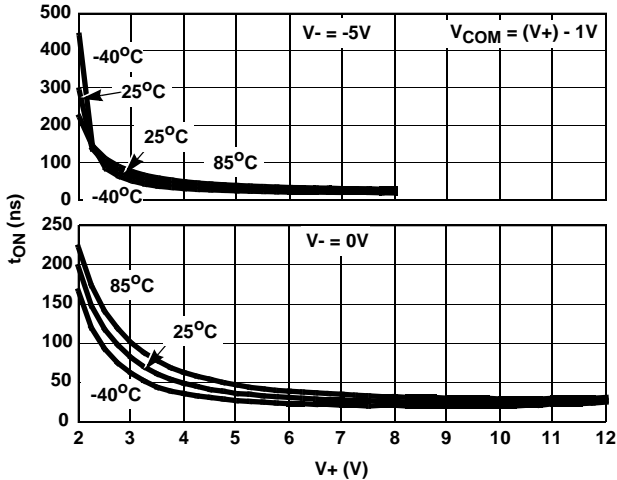

FIGURE 13. INHIBIT TURN - ON TIME vs SUPPLY VOLTAGE

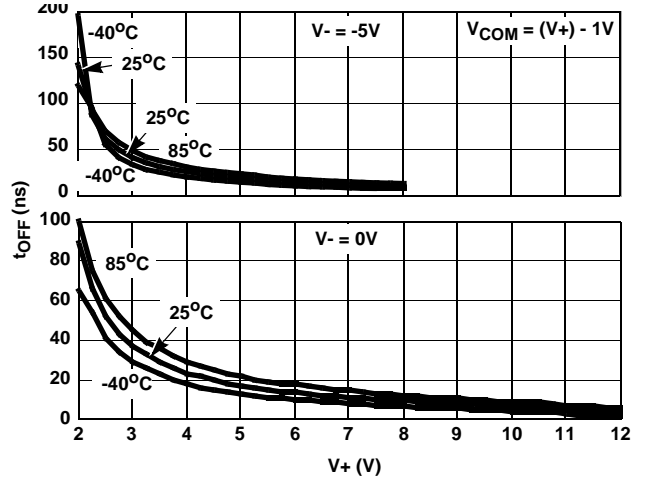

FIGURE 14. INHIBIT TURN - OFF TIME vs SUPPLY VOLTAGE

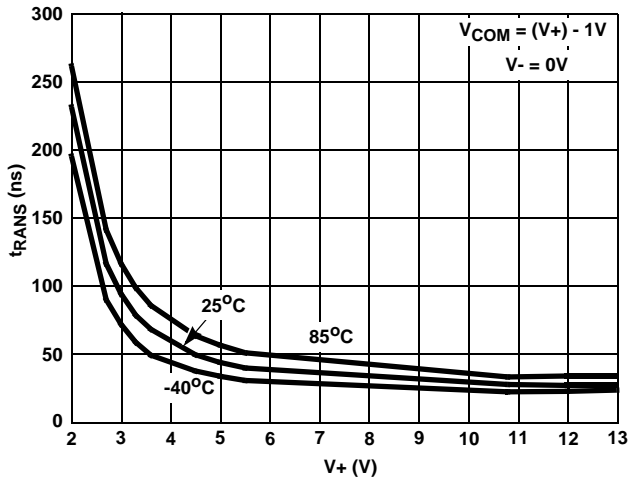

FIGURE 15. ADDRESS TRANS TIME vs SINGLE SUPPLY VOLTAGE

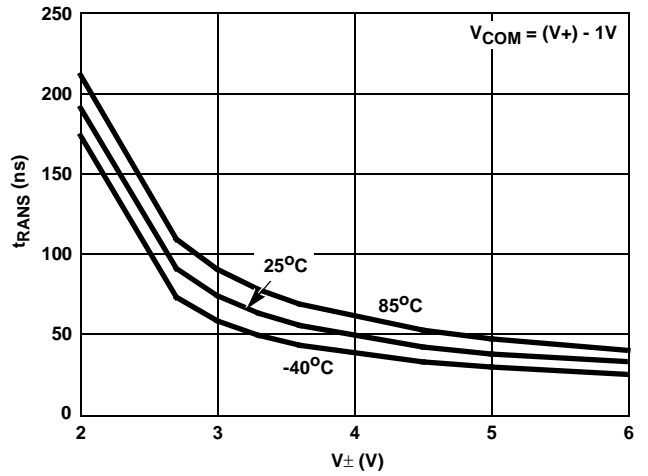

FIGURE 16. ADDRESS TRANS TIME vs DUAL SUPPLY VOLTAGE

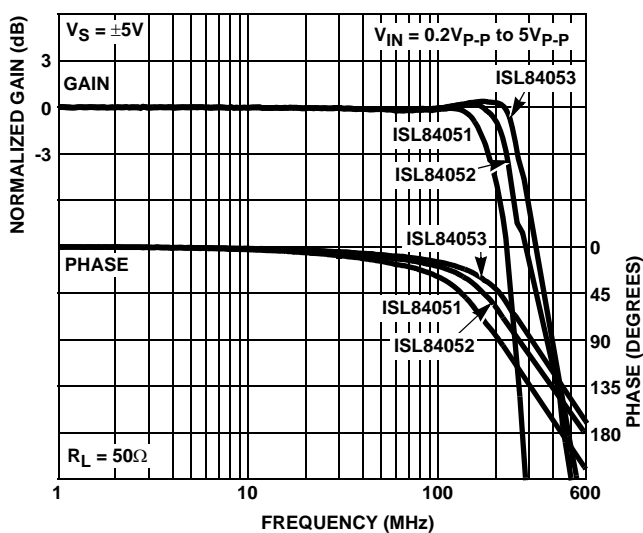

FIGURE 17. FREQUENCY RESPONSE

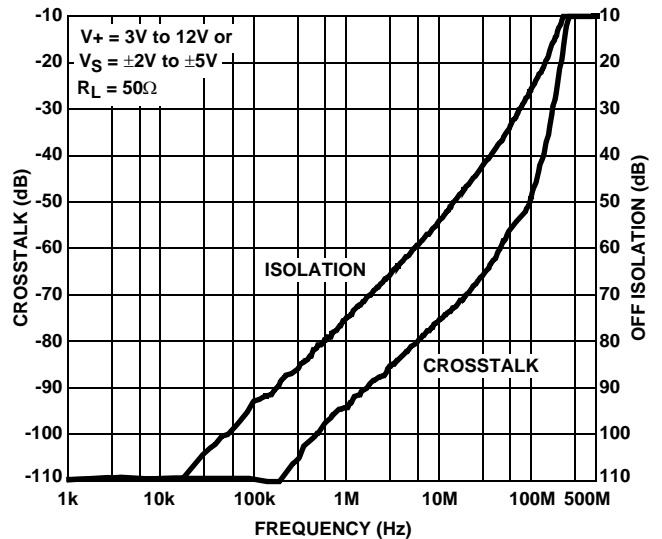

FIGURE 18. CROSSTALK AND OFF ISOLATION

***Die Characteristics***

**SUBSTRATE POTENTIAL (POWERED UP):**

GND

**TRANSISTOR COUNT:**

ISL84051: 193

ISL84052: 193

ISL84053: 193

**PROCESS:**

Si Gate CMOS

**Small Outline Plastic Packages (SOIC)**

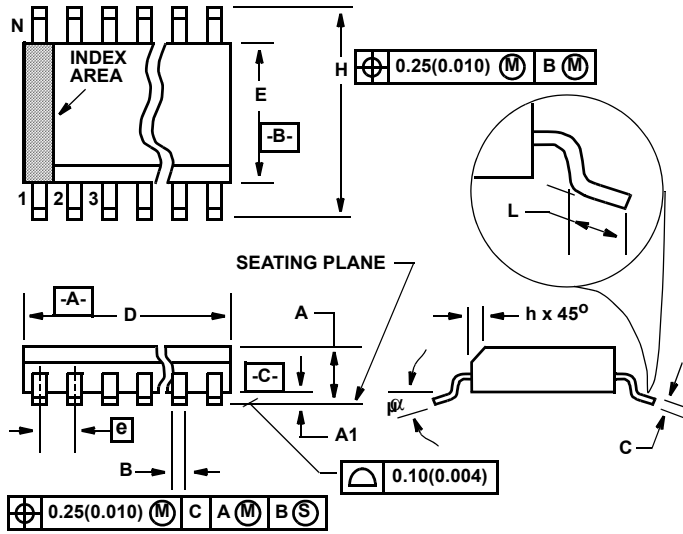

**M16.15 (JEDEC MS-012-AC ISSUE C)  
16 LEAD NARROW BODY SMALL OUTLINE PLASTIC PACKAGE**

SYMBOL	INCHES		MILLIMETERS		NOTES
	MIN	MAX	MIN	MAX	
A	0.053	0.069	1.35	1.75	-
A1	0.004	0.010	0.10	0.25	-
B	0.014	0.019	0.35	0.49	9
C	0.007	0.010	0.19	0.25	-
D	0.386	0.394	9.80	10.00	3
E	0.150	0.157	3.80	4.00	4
e	0.050 BSC		1.27 BSC		-
H	0.228	0.244	5.80	6.20	-
h	0.010	0.020	0.25	0.50	5
L	0.016	0.050	0.40	1.27	6
N	16		16		7
$\alpha$	0°	8°	0°	8°	-

Rev. 1 02/02

**NOTES:**

1. Symbols are defined in the "MO Series Symbol List" in Section 2.2 of Publication Number 95.
2. Dimensioning and tolerancing per ANSI Y14.5M-1982.
3. Dimension "D" does not include mold flash, protrusions or gate burrs. Mold flash, protrusion and gate burrs shall not exceed 0.15mm (0.006 inch) per side.
4. Dimension "E" does not include interlead flash or protrusions. Interlead flash and protrusions shall not exceed 0.25mm (0.010 inch) per side.
5. The chamfer on the body is optional. If it is not present, a visual index feature must be located within the crosshatched area.
6. "L" is the length of terminal for soldering to a substrate.
7. "N" is the number of terminal positions.
8. Terminal numbers are shown for reference only.
9. The lead width "B", as measured 0.36mm (0.014 inch) or greater above the seating plane, shall not exceed a maximum value of 0.61mm (0.024 inch)
10. Controlling dimension: MILLIMETER. Converted inch dimensions are not necessarily exact.

Shrink Small Outline Plastic Packages (SSOP)

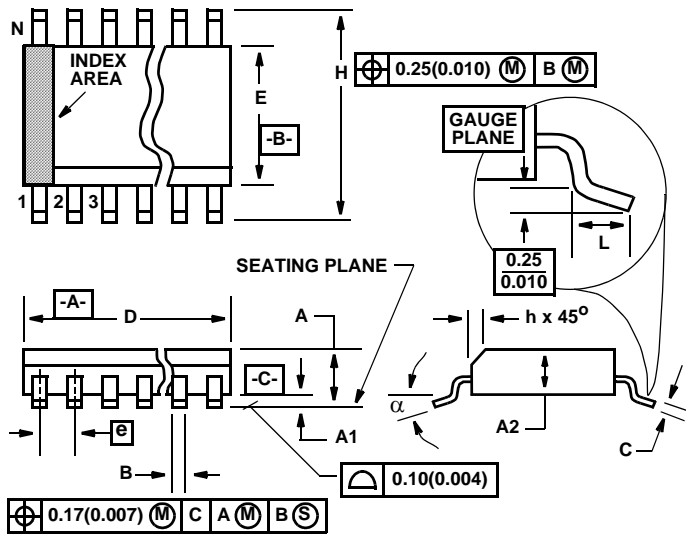

**M16.15A**  
16 LEAD SHRINK NARROW BODY SMALL OUTLINE PLASTIC PACKAGE

SYMBOL	INCHES		MILLIMETERS		NOTES
	MIN	MAX	MIN	MAX	
A	0.061	0.068	1.55	1.73	-
A1	0.004	0.0098	0.102	0.249	-
A2	0.055	0.061	1.40	1.55	-
B	0.008	0.012	0.20	0.31	9
C	0.0075	0.0098	0.191	0.249	-
D	0.189	0.196	4.80	4.98	3
E	0.150	0.157	3.81	3.99	4
e	0.025 BSC		0.635 BSC		-
H	0.230	0.244	5.84	6.20	-
h	0.010	0.016	0.25	0.41	5
L	0.016	0.035	0.41	0.89	6
N	16		16		7
$\alpha$	0°	8°	0°	8°	-

NOTES:

1. Symbols are defined in the "MO Series Symbol List" in Section 2.2 of Publication Number 95.
2. Dimensioning and tolerancing per ANSI Y14.5M-1982.
3. Dimension "D" does not include mold flash, protrusions or gate burrs. Mold flash, protrusion and gate burrs shall not exceed 0.15mm (0.006 inch) per side.
4. Dimension "E" does not include interlead flash or protrusions. Interlead flash and protrusions shall not exceed 0.25mm (0.010 inch) per side.
5. The chamfer on the body is optional. If it is not present, a visual index feature must be located within the crosshatched area.
6. "L" is the length of terminal for soldering to a substrate.
7. "N" is the number of terminal positions.
8. Terminal numbers are shown for reference only.
9. Dimension "B" does not include dambar protrusion. Allowable dambar protrusion shall be 0.10mm (0.004 inch) total in excess of "B" dimension at maximum material condition.
10. Controlling dimension: INCHES. Converted millimeter dimensions are not necessarily exact.

Rev. 1 2/02

All Intersil U.S. products are manufactured, assembled and tested utilizing ISO9000 quality systems. Intersil Corporation's quality certifications can be viewed at [www.intersil.com/design/quality](http://www.intersil.com/design/quality)

*Intersil products are sold by description only. Intersil Corporation reserves the right to make changes in circuit design, software and/or specifications at any time without notice. Accordingly, the reader is cautioned to verify that data sheets are current before placing orders. Information furnished by Intersil is believed to be accurate and reliable. However, no responsibility is assumed by Intersil or its subsidiaries for its use; nor for any infringements of patents or other rights of third parties which may result from its use. No license is granted by implication or otherwise under any patent or patent rights of Intersil or its subsidiaries.*

For information regarding Intersil Corporation and its products, see [www.intersil.com](http://www.intersil.com)

This datasheet has been downloaded from:

[www.DatasheetCatalog.com](http://www.DatasheetCatalog.com)

Datasheets for electronic components.



LittleDiode supplies new, hard to find or obsolete electronic components and semiconductors all over the world.

With over two million different components listed you are sure to find the part you need.

Feel free to visit us today at our online store:

[LittleDiode.com](http://LittleDiode.com)

Looking forward to providing you with the best possible service.