

1. General description

The ISP1161 is a single-chip Universal Serial Bus (USB) Host Controller (HC) and Device Controller (DC) which complies with *Universal Serial Bus Specification Rev 1.1*. These two USB controllers, the HC and the DC, share the same microprocessor bus interface. They have the same data bus, but different I/O locations. They also have separate interrupt request output pins, separate DMA channels that include separate DMA request output pins and DMA acknowledge input pins. This makes it possible for a microprocessor to control both the USB HC and the USB DC at the same time.

ISP1161 provides two downstream ports for the USB HC and one upstream port for the USB DC. Each downstream port has its own overcurrent (OC) detection input pin and power supply switching control output pin. The upstream port has its own V_{BUS} detection input pin. ISP1161 also provides separate wakeup input pins and suspended status output pins for the USB HC and the USB DC, respectively. This makes power management flexible. The downstream ports for the HC can be connected with any USB compliant USB devices and USB hubs that have USB upstream ports. The upstream port for the DC can be connected to any USB compliant USB host and USB hubs that have USB downstream ports.

The DC is compliant with most device class specifications such as Imaging Class, Mass Storage Devices, Communication Devices, Printing Devices and Human Interface Devices.

ISP1161 is well suited for embedded systems and portable devices that require a USB host only, a USB device only, or a combined and configurable USB host and USB device capabilities. ISP1161 brings high flexibility to the systems that have it built-in. For example, a system that has ISP1161 built-in allows it not only to be connected to a PC or USB hub that has a USB downstream port, but also to be connected to a device that has a USB upstream port such as a USB printer, USB camera, USB keyboard, USB mouse, among others. ISP1161 enables peer-to-peer connectivity between embedded systems. An interesting application example is to connect a ISP1161 HC with a ISP1161 DC.

Let us see an example of ISP1161 being used in a Digital Still Camera (DSC) design. **Figure 1** shows ISP1161 being used as a USB DC. **Figure 2** shows ISP1161 being used as a USB HC. **Figure 3** shows ISP1161 being used as a USB HC and a USB DC at the same time.

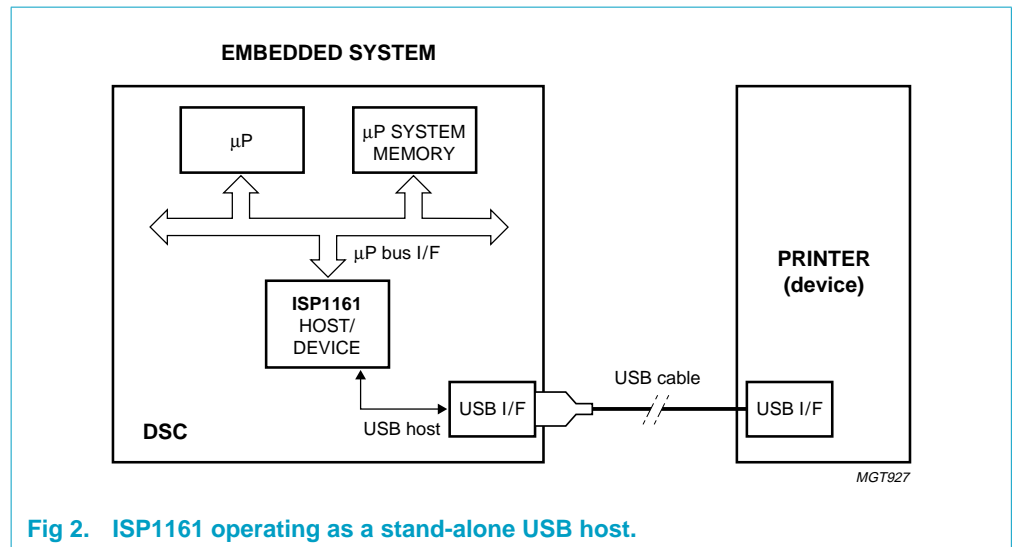
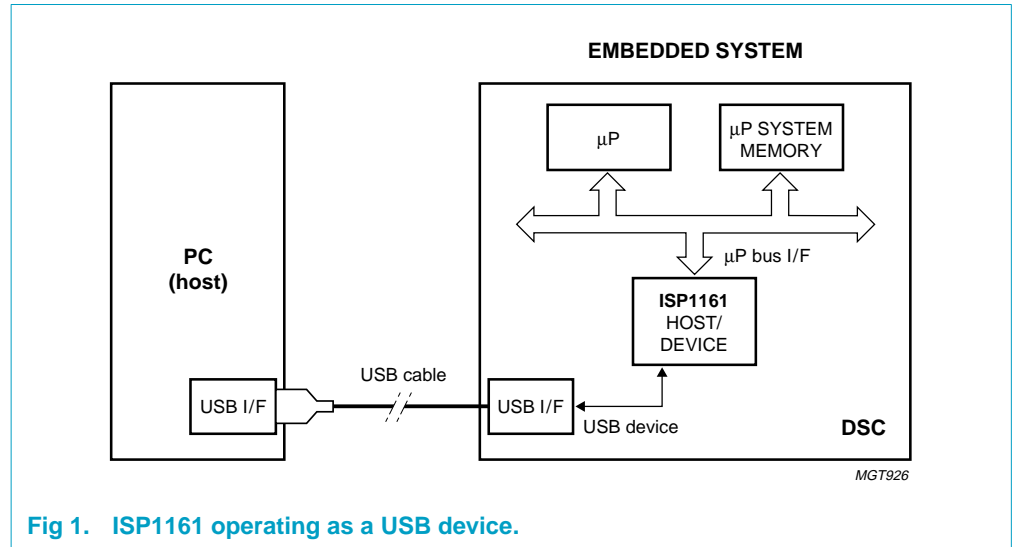

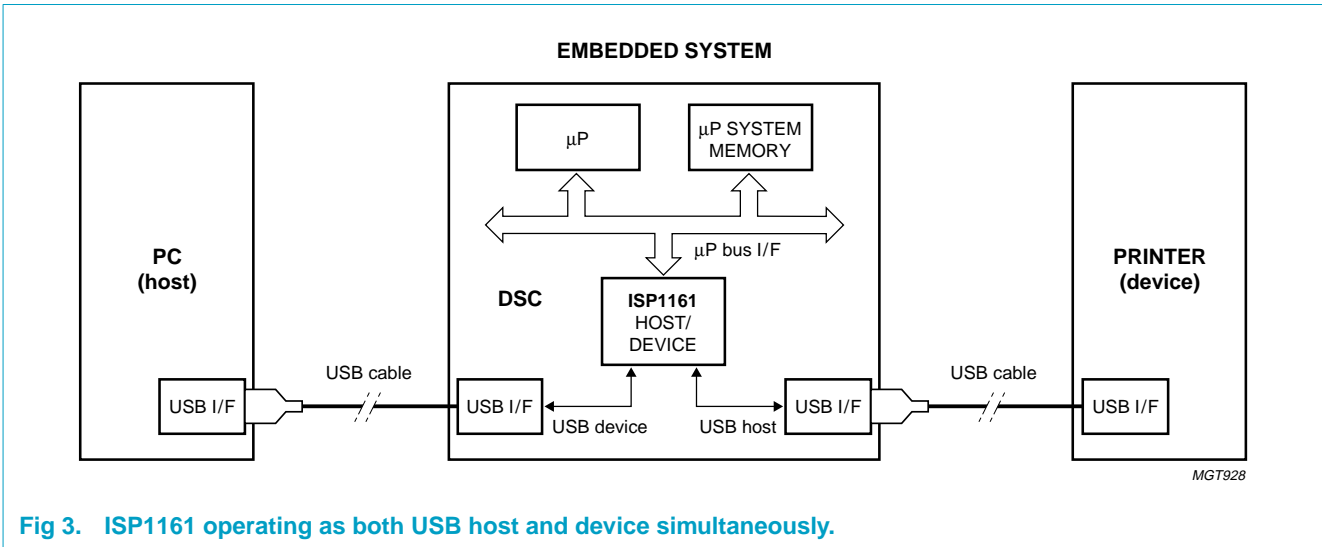

Fig 3. ISP1161 operating as both USB host and device simultaneously.

2. Features

- Complies with *Universal Serial Bus Specification Rev 1.1*
- Combines HC and DC in a single chip
- On-chip DC complies with most Device Class specifications
- Both HC and DC can be accessed by an external microprocessor via separate I/O port addresses
- Selectable one or two downstream ports for HC and one upstream port for DC
- High speed parallel interface to most of the generic microprocessors and Reduced Instruction Set Computer (RISC) processors (Hitachi SH-3 and SH-4, MIPS-based RISC, ARM7/9, StrongARM, etc.). Maximum 15 Mbyte/s data transfer rate between microprocessor and the HC, 11.1 Mbyte/s data transfer rate between microprocessor and the DC
- Supports single-cycle burst mode and multiple-cycle burst mode DMA operations
- Up to 14 programmable USB endpoints with 2 fixed control IN/OUT endpoints for the DC
- Built in separate FIFO buffer RAM for HC (4 kbytes) and DC (2462 bytes)
- Endpoints with double buffering to increase throughput and ease real-time data transfer for both DC transfers and HC isochronous (ISO) transactions
- 6 MHz crystal oscillator with integrated PLL for low EMI
- Controllable LazyClock (24 kHz) output during 'suspend'
- Clock output with programmable frequency (3 to 48 MHz)
- Software controlled connection to the USB bus (SoftConnect) on upstream port for the DC
- Good USB connection indicator that blinks with traffic (GoodLink) for the DC
- Built-in software selectable internal 15 kΩ pull-down resistors for HC downstream ports
- Dedicated pins for suspend sensing output and wakeup control input for flexible applications
- Global hardware reset input pin and separate internal software reset circuits for HC and DC

- Operation at either +5 V or +3.3 V power supply input
- 8 kV in-circuit ESD protection
- Operating temperature range –40 to +85 °C
- Available in two LQFP64 packages (SOT314-2 and SOT414-1).

3. Applications

- Personal Digital Assistant (PDA)
- Digital camera
- Third-generation (3-G) phone
- Set-top box (STB)
- Information Appliance (IA)
- Photo printer
- MP3 jukebox
- Game console.

4. Ordering information

Table 1: Ordering information

Type number	Package		
	Name	Description	Version
ISP1161BD	LQFP64	Plastic low profile quad flat package; 64 leads; body 10 x 10 x 1.4 mm	SOT314-2
ISP1161BM	LQFP64	Plastic low profile quad flat package; 64 leads; body 7 x 7 x 1.4 mm	SOT414-1

5. Block diagram

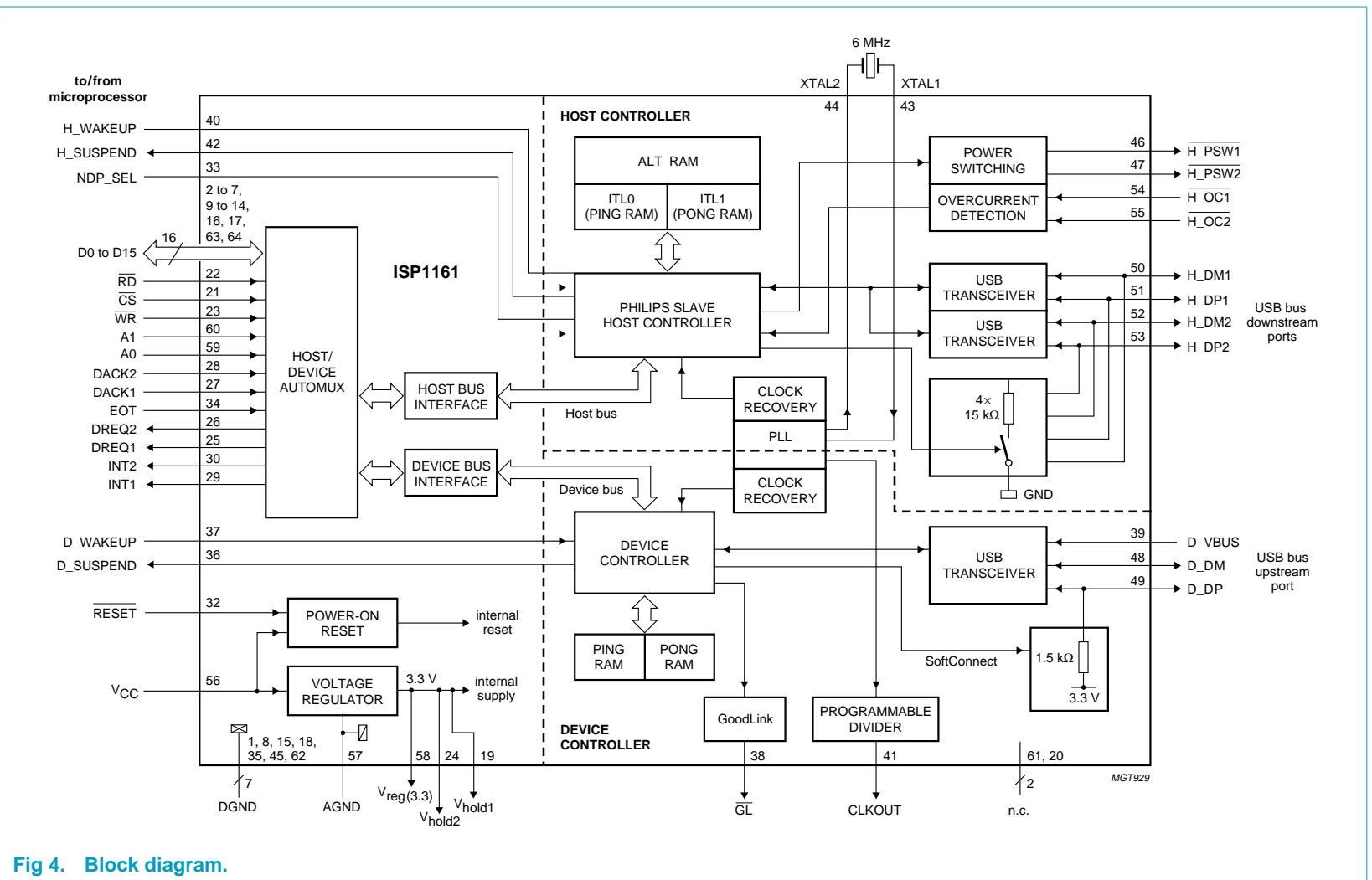

Fig 4. Block diagram.

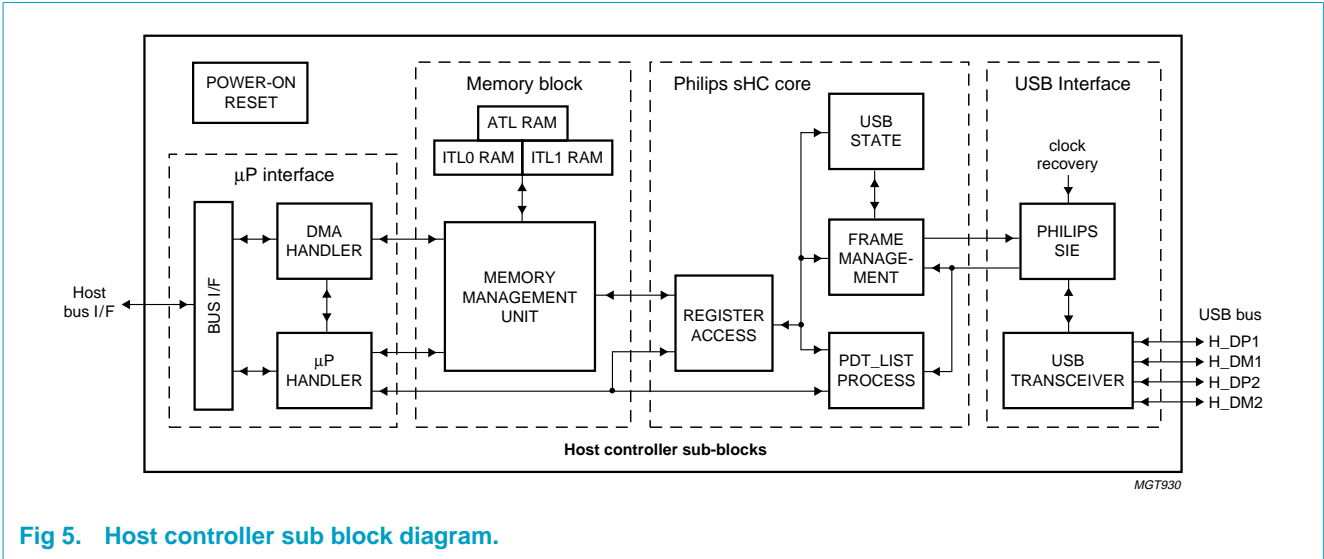

Fig 5. Host controller sub block diagram.

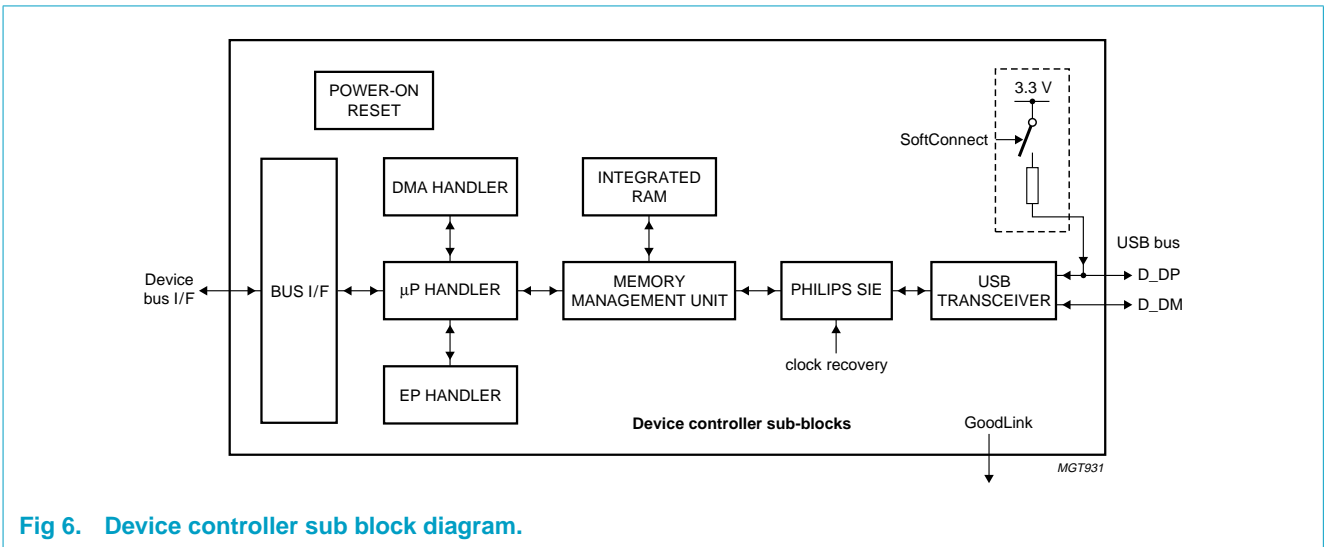

Fig 6. Device controller sub block diagram.

6. Pinning information

6.1 Pinning

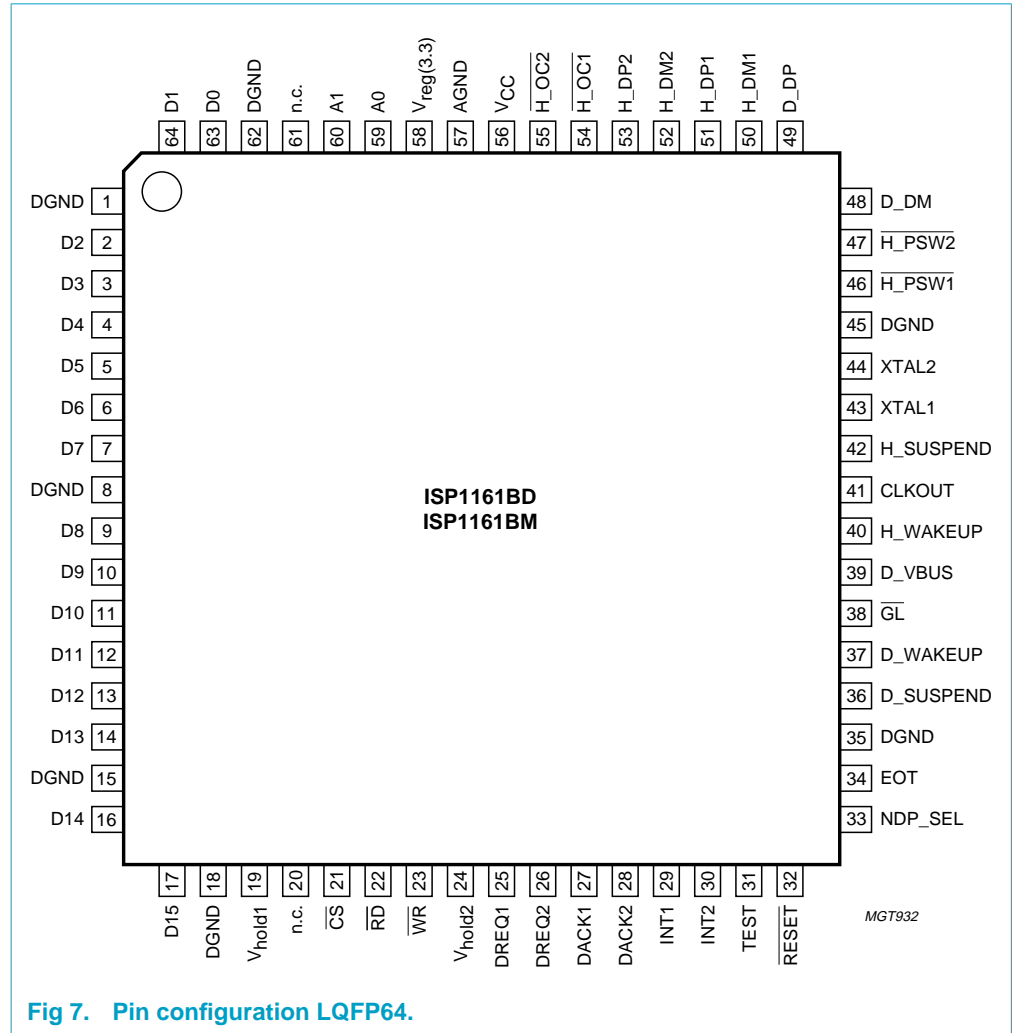

Fig 7. Pin configuration LQFP64.

6.2 Pin description

Table 2: Pin description for LQFP64

Symbol ^[1]	Pin	Type	Description
DGND	1	-	digital ground
D2	2	I/O	bit 2 of bidirectional data; slew-rate controlled; TTL input; three-state output
D3	3	I/O	bit 3 of bidirectional data; slew-rate controlled; TTL input; three-state output
D4	4	I/O	bit 4 of bidirectional data; slew-rate controlled; TTL input; three-state output
D5	5	I/O	bit 5 of bidirectional data; slew-rate controlled; TTL input; three-state output

Table 2: Pin description for LQFP64 ...continued

Symbol ^[1]	Pin	Type	Description
D6	6	I/O	bit 6 of bidirectional data; slew-rate controlled; TTL input; three-state output
D7	7	I/O	bit 7 of bidirectional data; slew-rate controlled; TTL input; three-state output
DGND	8	-	digital ground
D8	9	I/O	bit 8 of bidirectional data; slew-rate controlled; TTL input; three-state output
D9	10	I/O	bit 9 of bidirectional data; slew-rate controlled; TTL input; three-state output
D10	11	I/O	bit 10 of bidirectional data; slew-rate controlled; TTL input; three-state output
D11	12	I/O	bit 11 of bidirectional data; slew-rate controlled; TTL input; three-state output
D12	13	I/O	bit 12 of bidirectional data; slew-rate controlled; TTL input; three-state output
D13	14	I/O	bit 13 of bidirectional data; slew-rate controlled; TTL input; three-state output
DGND	15	-	digital ground
D14	16	I/O	bit 14 of bidirectional data; slew-rate controlled; TTL input; three-state output
D15	17	I/O	bit 15 of bidirectional data; slew-rate controlled; TTL input; three-state output
DGND	18	-	digital ground
V _{hold1}	19	-	voltage holding pin; this pin is internally connected to the V _{reg(3.3)} and V _{hold2} pins. When the V _{CC} pin is connected to +5 V, this pin will output 3.3 V, hence it should not be connected to +5 V. When the V _{CC} pin is connected to +3.3 V, this pin can either be connected to +3.3 V or left unconnected. In all cases this pin should be decoupled to DGND.
n.c.	20	-	no connection
CS	21	I	chip select input
RD	22	I	read strobe input
WR	23	I	write strobe input
V _{hold2}	24	-	voltage holding pin; this pin is internally connected to the V _{reg(3.3)} and V _{hold1} pins. When the V _{CC} pin is connected to +5 V, this pin will output 3.3 V, hence it should not be connected to +5 V. When the V _{CC} pin is connected to +3.3 V, this pin can either be connected to +3.3 V or left unconnected. In all cases this pin should be decoupled to DGND.
DREQ1	25	O	HC's DMA request output (programmable polarity); signals to the DMA controller that the ISP1161 wants to start a DMA transfer; see HcHardwareConfiguration register (20H/A0H)

Table 2: Pin description for LQFP64 ...continued

Symbol ^[1]	Pin	Type	Description
DREQ2	26	O	DC's DMA request output (programmable polarity); signals to the DMA controller that the ISP1161 wants to start a DMA transfer; see DC's hardware configuration register (BAH/BBH)
DACK1	27	I	HC's DMA acknowledge input. Active level programmable. See the HcHardwareConfiguration register (20H/A0H)
DACK2	28	I	DC's DMA acknowledge input. Active level programmable. See DC's hardware configuration register (BAH/BBH)
INT1	29	O	HC's interrupt output; programmable level, edge triggered and polarity; see HcHardwareConfiguration register (20H, A0H)
INT2	30	O	DC's interrupt output; programmable level, edge triggered and polarity; see DC's hardware configuration register (BAH, BBH)
TEST	31	O	Test output; this pin is used for test purposes only.
RESET	32	I	reset input (Schmitt trigger); a LOW level produces an asynchronous reset
NDP_SEL	33	I	number of downstream ports: 0 — select 1 downstream port 1 — select 2 downstream ports only changes the value of the NDP field in the HcRhDescriptorA register; there will always be two ports present in the UsbSlaveHost
EOT	34	I	DMA master device to inform ISP1161 of end of DMA transfer (Active level is programmable), see HcHardwareConfiguration register (20H/A0H)
DGND	35	-	digital ground
D_SUSPEND	36	O	DC's suspend' state indicator output; active level programmable
D_WAKEUP	37	I	DC's wake-up input (edge triggered); a LOW-to-HIGH transition generates a remote wake-up from 'suspend' state
GL	38	O	GoodLink LED indicator output (open-drain); the LED is default ON, blinks OFF upon USB traffic; blinking can be disabled by setting bit 1 of MODE register to a 1
D_VBUS	39	I	DC's USB upstream port V _{BUS} sensing input
H_WAKEUP	40	I	HC's wake-up input (edge triggered); a LOW-to-HIGH transition generates a remote wake-up from 'suspend' state
CLKOUT	41	O	programmable clock output (3 to 48 MHz); default 12 MHz
H_SUSPEND	42	O	HC's suspend' state indicator output; active level programmable
XTAL1	43	I	crystal oscillator input (6 MHz); connect a fundamental mode or third-overtone, parallel-resonant crystal or an external clock source (leaving pin XTAL2 unconnected)

Table 2: Pin description for LQFP64 ...continued

Symbol ^[1]	Pin	Type	Description
XTAL2	44	O	crystal oscillator output (6 MHz); connect a fundamental mode or third-overtone, parallel-resonant crystal; leave this pin open when using an external clock source on pin XTAL1
DGND	45	-	digital ground
$\overline{\text{H_PSW1}}$	46	O	power switching control output for downstream port 1; open drain output
$\overline{\text{H_PSW2}}$	47	O	power switching control output for downstream port 2; open drain output
D_DM	48	AI/O	USB D- data line for DC's upstream port
D_DP	49	AI/O	USB D+ data line for DC's upstream port
H_DM1	50	AI/O	USB D- data line for HC's downstream port 1
H_DP1	51	AI/O	USB D+ data line for HC's downstream port 1
H_DM2	52	AI/O	USB D- data line for HC's downstream port 2
H_DP2	53	AI/O	USB D+ data line for HC's downstream port 2
$\overline{\text{H_OC1}}$	54	I	overcurrent sensing input for HC's downstream port 1
$\overline{\text{H_OC2}}$	55	I	overcurrent sensing input for HC's downstream port 2
V _{CC}	56	-	digital power supply voltage input (3.0 to 3.6 V or 4.75 to 5.25 V). This pin connects to the internal 3.3 V regulator input. When connected to +5 V, the internal regulator will output 3.3 V to pins V _{reg(3.3)} , V _{hold1} and V _{hold2} . When connected to 3.3 V, it will bypass the internal regulator.
AGND	57	-	analog ground
V _{reg(3.3)}	58	-	internal 3.3 V regulator output; When the V _{CC} pin is connected to +5 V, this pin outputs 3.3 V. When the V _{CC} pin is connected to +3.3 V, then this pin should also be connected to +3.3 V.
A0	59	I	address input; selects command (A0 = 1) or data (A0 = 0)
A1	60	I	address input; selects AutoMux switching to DC (A1 = 1) or AutoMux switching to HC (A1 = 0); see Table 3
n.c.	61	-	no connection
DGND	62	-	digital ground
D0	63	I/O	bit 0 of bidirectional data; slew-rate controlled; TTL input; three-state output
D1	64	I/O	bit 1 of bidirectional data; slew-rate controlled; TTL input; three-state output

[1] Symbol names with an overscore (e.g. $\overline{\text{NAME}}$) represent active LOW signals.

7. Functional description

7.1 PLL clock multiplier

A 6 to 48 MHz clock multiplier Phase-Locked Loop (PLL) is integrated on-chip. This allows for the use of a low-cost 6 MHz crystal, which also minimizes EMI. No external components are required for the operation of the PLL.

7.2 Bit clock recovery

The bit clock recovery circuit recovers the clock from the incoming USB data stream using a 4× over-sampling principle. It is able to track jitter and frequency drift as specified by the *USB Specification Rev. 1.1*.

7.3 Analog transceivers

Three sets of transceiver are embedded in the chip: two are used for downstream ports with USB connector type A; one is used for upstream port with USB connector type B. The integrated transceivers are compliant with the *Universal Serial Bus Specification Rev 1.1*. They interface directly with the USB connectors and cables through external termination resistors.

7.4 Philips Serial Interface Engine (SIE)

The Philips SIE implements the full USB protocol layer. It is completely hardwired for speed and needs no firmware intervention. The functions of this block include: synchronization pattern recognition, parallel/serial conversion, bit (de)stuffing, CRC checking/generation, Packet Identifier (PID) verification/generation, address recognition, handshake evaluation/generation. There are separate SIE in both the HC and the DC.

7.5 SoftConnect (in DC)

The connection to the USB is accomplished by bringing D+ (for high-speed USB devices) HIGH through a 1.5 kΩ pull-up resistor. In the ISP1161 the 1.5 kΩ pull-up resistor is integrated on-chip and is not connected to V_{CC} by default. The connection is established through a command sent by the external/system microcontroller. This allows the system microcontroller to complete its initialization sequence before deciding to establish connection with the USB. Re-initialization of the USB connection can also be performed without disconnecting the cable.

The ISP1161 DC will check for USB V_{BUS} availability before the connection can be established. V_{BUS} sensing is provided through pin D_VBUS.

Remark: Note that the tolerance of the internal resistors is 25%. This is higher than the 5% tolerance specified by the USB specification. However, the overall V_{SE} voltage specification for the connection can still be met with a good margin. The decision to make use of this feature lies with the USB equipment designer.

7.6 GoodLink (in DC)

Indication of a good USB connection is provided at pin \overline{GL} through GoodLink technology. During enumeration the LED indicator will blink momentarily. When the ISP1161 has been successfully enumerated (the device address is set), the LED indicator will remain permanently on. Upon each successful packet transfer (with ACK) to and from the ISP1161 the LED will blink off for 100 ms. During 'suspend' state the LED will remain off.

This feature provides a user-friendly indicator of the status of the USB device, the connected hub and the USB traffic. It is a useful field diagnostics tool for isolating faulty equipment. It can therefore help to reduce field support and hotline overhead.

7.7 Suspend and wakeup (in DC)

ISP1161's DC also can be put into suspended state by toggling bit 5, GOSUSP, of the Mode Register. Pin D_SUSPEND is used for the DC's suspended state sensing output. The polarity of D_SUSPEND pin can be changed by setting bit 2, PWROFF, of the Hardware Configuration Register.

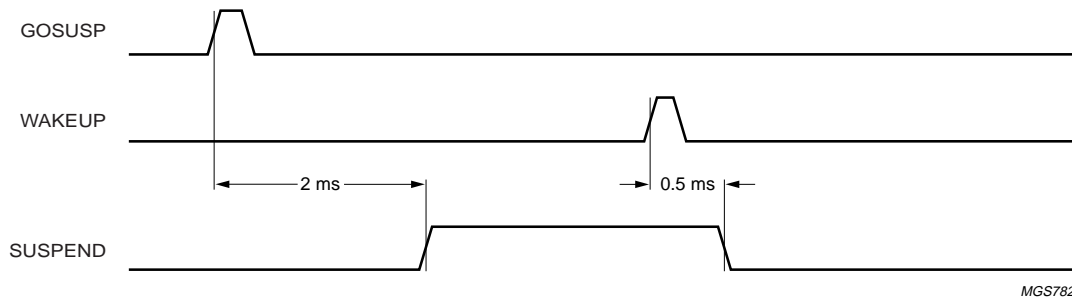

Fig 8. ISP1161 DC's suspend and wakeup.

There are some ways to resume ISP1161's DC from the suspended state:

- By USB host, drivers a K-state on the USB bus (global resume)
- By pin D_WAKEUP or \overline{CS} .

Figure 8 shows the timing relationship for DC going into suspended state, and resuming from the suspended state.

8. Microprocessor bus interface

8.1 I/O addressing mode

ISP1161 provides I/O addressing mode for external microprocessors to access its internal control registers and FIFO buffer RAM. I/O addressing mode has the advantage of reducing the pin count for address lines and so occupying less microprocessor resources. ISP1161 uses only two address lines: A1 and A0 to access the internal control registers and FIFO buffer RAM. Therefore, ISP1161 occupies only four I/O ports or four memory locations of a microprocessor. External

microprocessors can read or write ISP1161's internal control registers and FIFO buffer RAM through the parallel I/O (PIO) operating mode. Figure 9 shows the parallel I/O interface between a microprocessor and ISP1161.

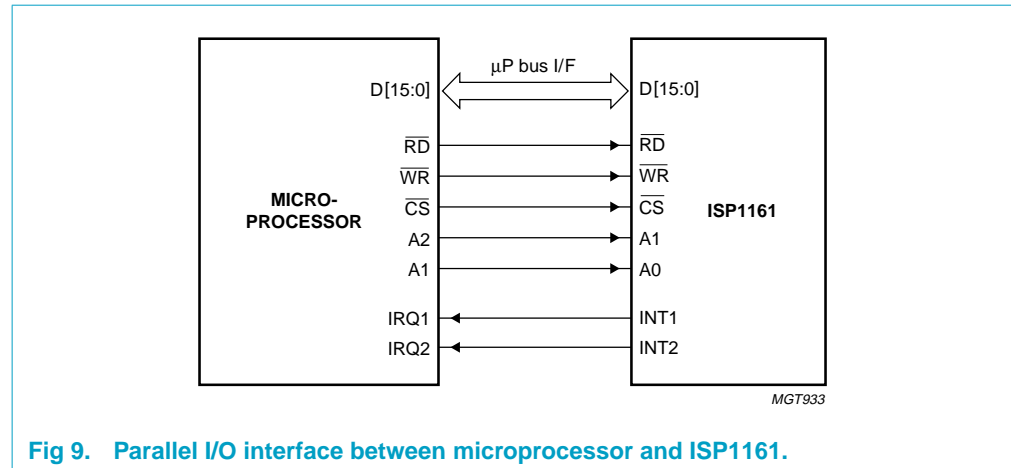

Fig 9. Parallel I/O interface between microprocessor and ISP1161.

8.2 DMA mode

ISP1161 also provides DMA mode for external microprocessors to access its internal FIFO buffer RAM. Data can be transferred by DMA operation between a microprocessor's system memory and ISP1161's internal FIFO buffer RAM. Note: the DMA operation must be controlled by the external microprocessor system's DMA controller (Master). Figure 10 shows the DMA interface between a microprocessor system and ISP1161. ISP1161 provides two DMA channels: DMA channel 1 (controlled by DREQ1, DACK1 signals) is for the DMA transfer between a microprocessor's system memory and ISP1161 HC's internal FIFO buffer RAM. DMA channel 2 (controlled by DREQ2, DACK2 signals) is for the DMA transfer between a microprocessor's system memory and ISP1161 DC's internal FIFO buffer RAM. The EOT signal is an external end-of-transfer signal used to terminate the DMA transfer. Some microprocessors may not have this signal. In this case, ISP1161 provides an internal EOT signal to terminate the DMA transfer as well. Setting the HcDMAConfiguration register (21H - Read, A1H - Write) enables ISP1161's HC internal DMA counter for DMA transfer. When the DMA counter reaches the value that is set in the HcTransferCounter (22H - Read, A2H - Write) register to be used as the byte count of the DMA transfer, the internal EOT signal will be generated to terminate the DMA transfer.

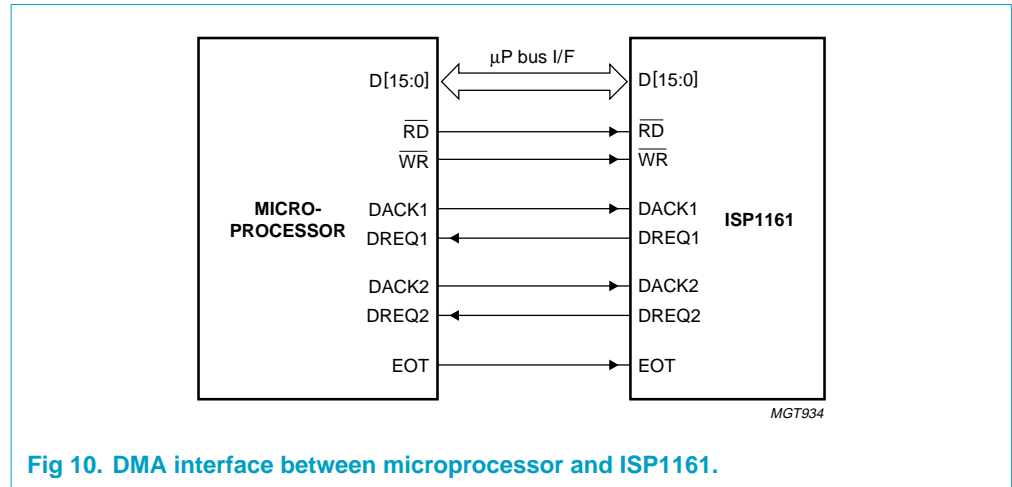

Fig 10. DMA interface between microprocessor and ISP1161.

8.3 Microprocessor read/write ISP1161's internal control registers by PIO mode

8.3.1 I/O port addressing

Table 3 shows ISP1161's I/O port addressing. Complete decoding of the I/O port address should include the chip select signal \overline{CS} and the address lines A1 and A0. However, the direction of the access of the I/O ports is controlled by the \overline{RD} and \overline{WR} signals. When \overline{RD} is LOW, the microprocessor reads data from ISP1161's data port. When \overline{WR} is LOW, the microprocessor writes a command to the command port, or writes data to the data port.

Table 3: I/O port addressing

Port	\overline{CS}	[A1:A0] (Bin)	Access	Data bus width (bits)	Description
0	0	00	R/W	16	HC data port
1	0	01	W	16	HC command port
2	0	10	R/W	16	DC data port
3	0	11	W	16	DC command port

Figure 11 and Figure 12 illustrate how an external microprocessor accesses ISP1161's internal control registers.

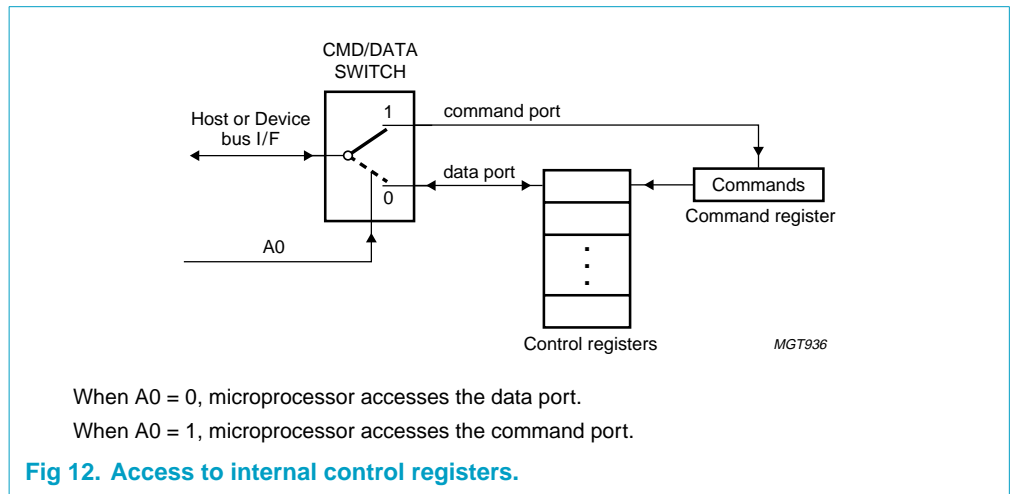
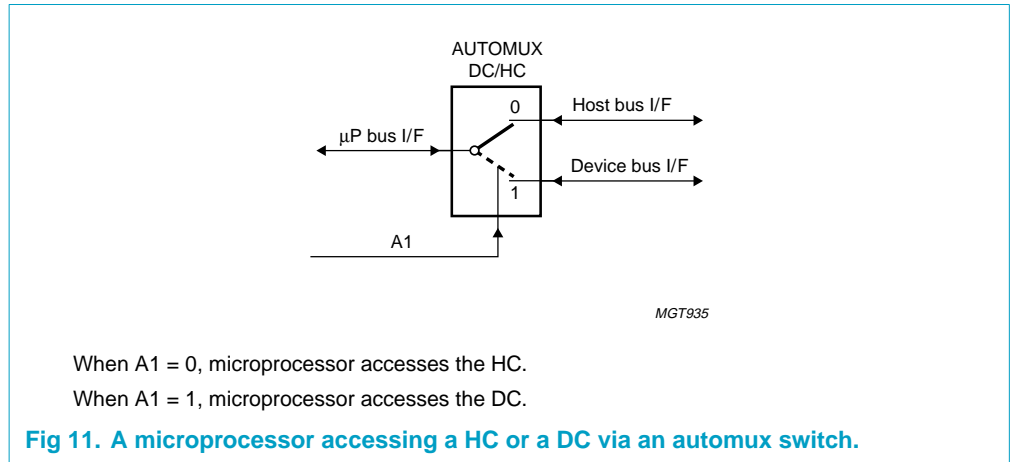

8.3.2 Register access phases

ISP1161's register structure is a command-data register pair structure. A complete register access cycle comprises a command phase followed by a data phase. The command (also known as the index of a register) points the ISP1161 to the next register to be accessed. A command is 8 bits long. On a microprocessor's 16-bit data bus, a command occupies the lower byte, with the upper byte filled with zeros.

Figure 13 shows a complete 16-bit register access cycle for ISP1161. The microprocessor writes a command code to the command port, and then reads from or writes the data word to the data port. Take the example of a microprocessor attempting to read a chip's ID, which is saved in the HC's HcChipID register (27H, read only) where its command code is 27H, read only. The 16-bit register access cycle is therefore:

1. Microprocessor writes the command code of 27H (0027H in 16-bit width) to ISP1161's HC command port
2. Microprocessor reads the data word of the chip's ID (6110H) from ISP1161's HC data port.

For ISP1161's ES1 (engineering sample: version one), the chip's ID is 6110H, where the upper byte of 61H stands for ISP1161, and the lower byte of 10H stands for the first version of the IC chip.

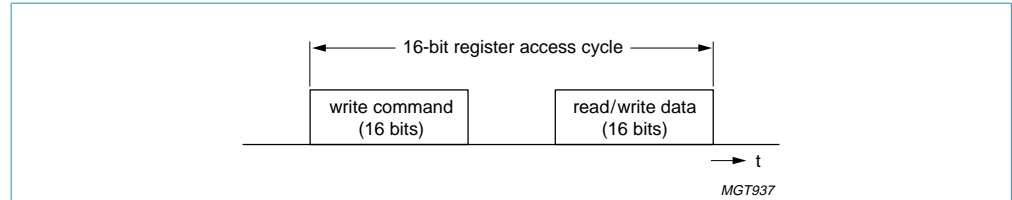

Fig 13. 16-bit register access cycle.

Most of ISP1161's internal control registers are 16 bits wide. Some of the internal control registers, however, have 32-bit width. Figure 14 shows how ISP1161's 32-bit internal control register is accessed. The complete cycle of accessing a 32-bit register consists of a command phase followed by two data phases. In the two data phases, the microprocessor should first read or write the lower 16-bit data, followed by the upper 16-bit data.

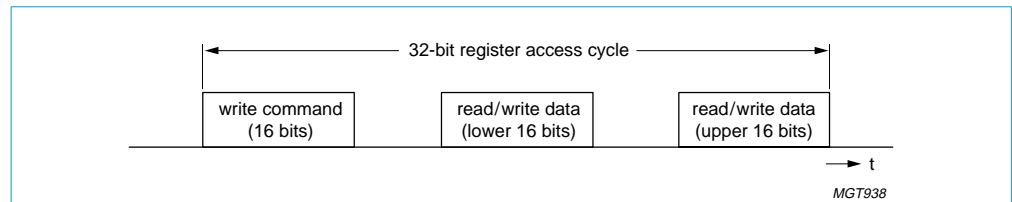

Fig 14. 32-bit register access cycle.

To further describe the complete access cycles of ISP1161's internal control registers, the status of some pin signals of the microprocessor bus interface are shown in Figure 15 and Figure 16 for the HC and the DC respectively.

Signals	Valid status	Valid status	Valid status
\overline{CS}	0	0	0
A1, A0	01	00	00
\overline{RD} , \overline{WR}	$\overline{RD} = 1$, $\overline{WR} = 0$	$\overline{RD} = 0$ (read) or $\overline{WR} = 0$ (write)	$\overline{RD} = 0$ (read) or $\overline{WR} = 0$ (write)
data bus	Command code	Register data (lower word)	Register data (upper word)

MGT939

Fig 15. Accessing ISP1161 HC control registers.

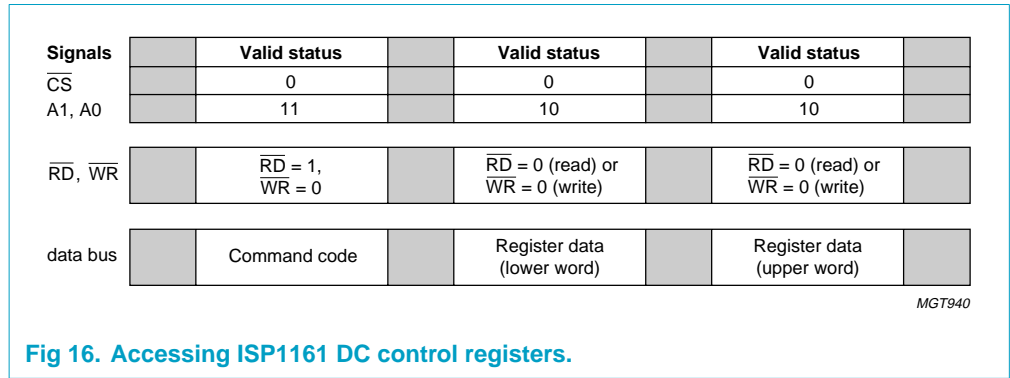

8.4 Microprocessor read/write ISP1161's internal FIFO buffer RAM by PIO mode

Since ISP1161's internal memory is structured as a FIFO buffer RAM, the FIFO buffer RAM is mapped to dedicated register fields. Therefore, accessing ISP1161's internal FIFO buffer RAM is just like accessing the internal control registers in multiple data phases.

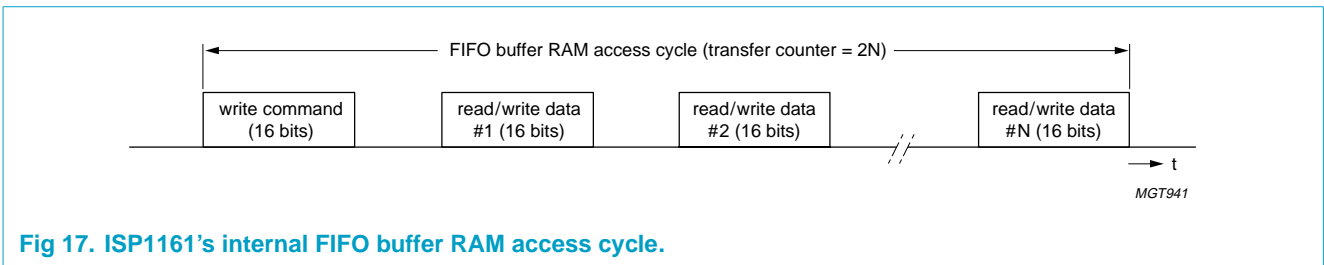

Figure 17 shows a complete access cycle of ISP1161's internal FIFO buffer RAM. For a write cycle, the microprocessor first writes the FIFO buffer RAM's command code to the command port, and then writes the data words one by one to the data port until half of the transfer's byte count is reached. The HcTransferCounter register (22H - Read, A2H - Write) is used to specify the byte count of a FIFO buffer RAM's read cycle or write cycle. Every access cycle must be in the same access direction. The read cycle procedure is similar to the write cycle.

For ISP1161 DC's FIFO buffer RAM access, see [Section 11](#).

8.5 Microprocessor read/write ISP1161's internal FIFO buffer RAM by DMA mode

The DMA interface between a microprocessor and ISP1161 is shown in [Figure 10](#).

When doing a DMA transfer, at the beginning of every burst the ISP1161 outputs a DMA request to the microprocessor via the DREQ pin (DREQ1 for HC, DREQ2 for DC). After receiving this signal, the microprocessor will reply with a DMA acknowledge to ISP1161 via the DACK pin (DACK1 for HC, DACK2 for DC), and at the same time, do the DMA transfer through the data bus. For normal DMA mode, the

microprocessor must still issue a \overline{RD} or \overline{WR} signal to ISP1161's \overline{RD} or \overline{WR} pin. (DACK Only mode does not need the \overline{RD} or \overline{WR} signal.) ISP1161 will repeat the DMA cycles until it receives an EOT signal to terminate the DMA transfer.

ISP1161 supports both external EOT and internal EOT signals. The external EOT signal is received as input from ISP1161's EOT pin: it generally comes from the external microprocessor. The internal EOT signal is generated by ISP1161 internally.

To select either, set the DMA configuration registers. For example, for the HC, setting bit 2 of the HcDMAConfiguration register (21H - Read, A1H - Write) to 1 will enable the DMA counter for DMA transfer. When the DMA counter reaches the value of HcTransferCounter register, the internal EOT signal will be generated to terminate the DMA transfer.

ISP1161 supports either single-cycle burst mode DMA operation or multiple-cycle burst mode DMA operation.

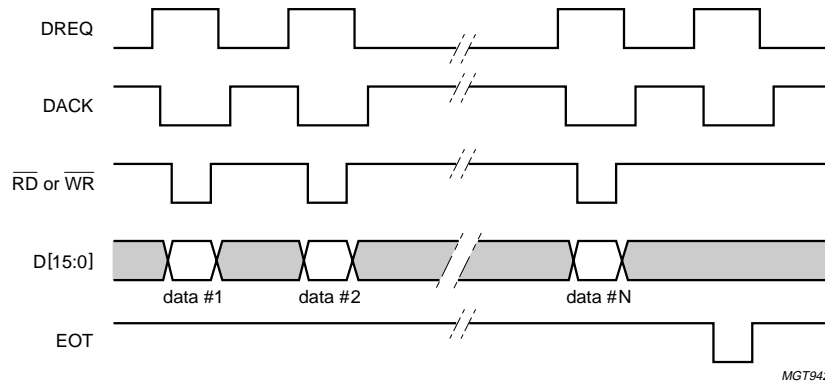

N = 1/2 byte count of transfer data.

Fig 18. DMA transfer for single-cycle burst mode.

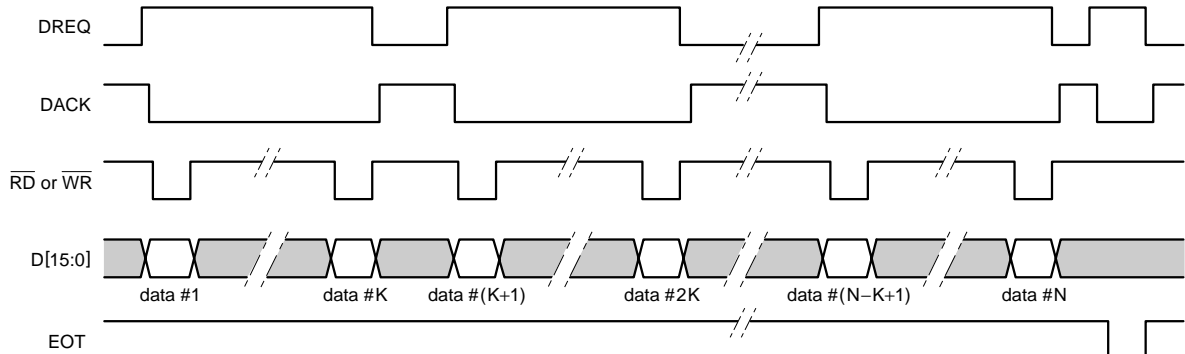

N = 1/2 byte count of transfer data, K = number of cycles/burst.

Fig 19. DMA transfer for multi-cycle burst mode.

In both figures, the DMA transfer is configured such that DREQ is active HIGH and DACK is active LOW.

8.6 Interrupts

ISP1161 has separate interrupt request pins for the USB HC (INT1) and the USB DC (INT2).

8.6.1 Pin configuration

The interrupt output signals have four configuration modes:

- Level trigger, active LOW
- Level trigger, active HIGH
- Edge trigger, active LOW
- Edge trigger, active HIGH.

Figure 20 shows these four interrupt configuration modes. They are programmable through register settings, which are also used to disable or enable the signals.

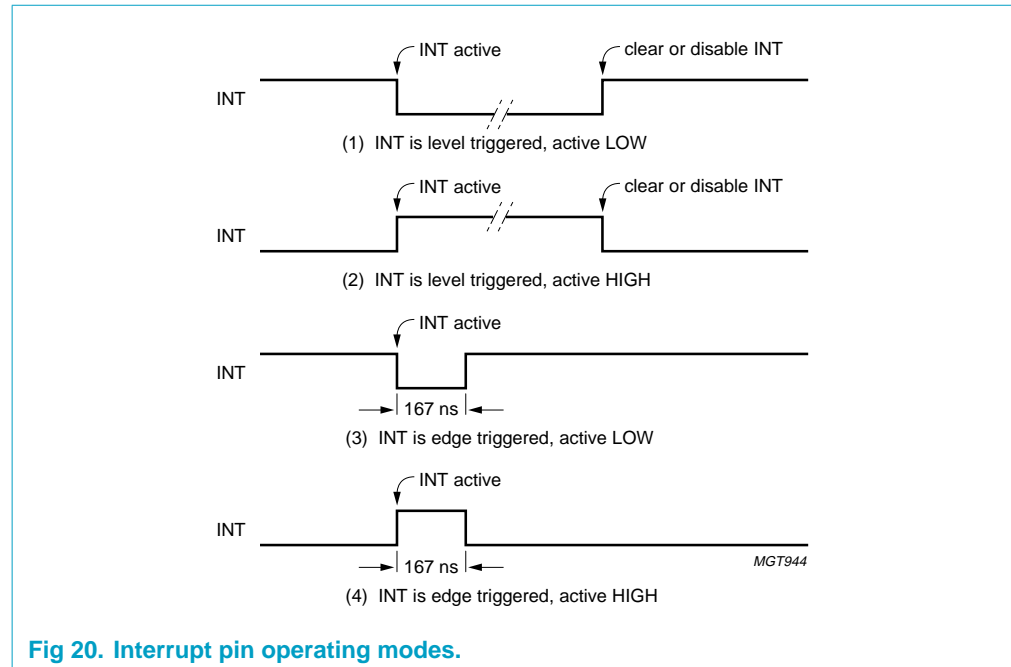

8.6.2 HC's interrupt output pin (INT1)

To program the four configuration modes of the HC's interrupt output signal (INT1), set bits 1 and 2 of the HcHardwareConfiguration register (20H - Read, A0H - Write). Bit 0 is used as the master enable setting for pin INT1.

INT1 has many interrupt events. The relationship between pin INT1 and its interrupt events is shown as in Figure 21.

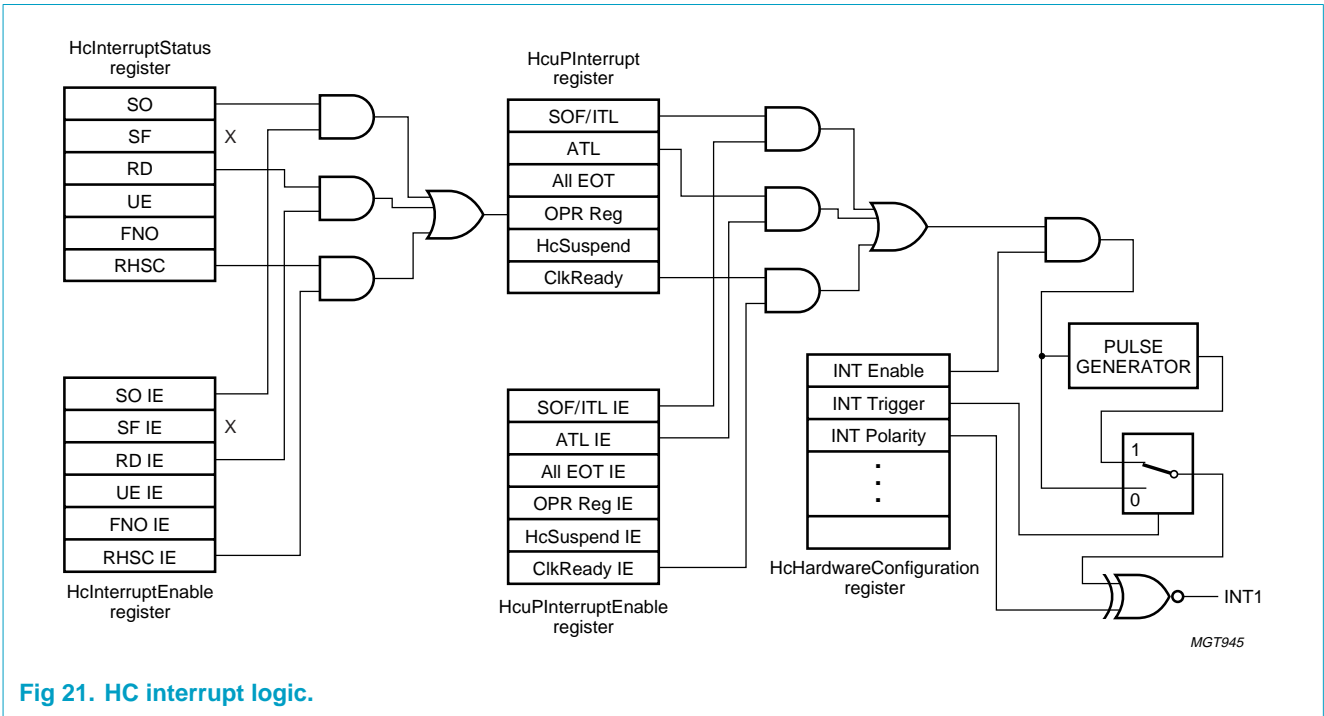

Fig 21. HC interrupt logic.

The interrupt events of the HcuPIInterrupt register (24H - Read, A4H - Write) changes the status of pin INT1 when the corresponding bits of the HcuPIInterruptEnable register (25H - Read, A5H - Write) and pin INT1's global enable bit (bit 0 of the HcHardwareConfiguration register) are all set to enable status.

However, events that come from the HcInterruptStatus register (03H - Read, 83H - Write) affect only the OPR_Reg bit of the HcuPIInterrupt register. They cannot directly change the status of pin INT1.

8.6.3 DC's interrupt output pin (INT2)

The DC's interrupt output pin INT2's four configuration modes can also be programmed by setting bit 0 (INTPOL) and bit 1 (INTLVL) of the DC's hardware configuration register (BBH - Read, BAH - Write). Bit 3 (INTENA) of the DC's mode register (B9H - Read, B8H - Write) is used as pin INT2's global enable setting.

Figure 22 shows the relationship between the interrupt events and pin INT2.

Each of the indicated USB events is logged in a status bit of the Interrupt Register. Corresponding bits in the Interrupt Enable Register determine whether or not an event will generate an interrupt.

Interrupts can be masked globally by means of the INTENA bit of the Mode Register (see Table 80).

The active level and signalling mode of the INT output is controlled by the INTPOL and INTLVL bits of the Hardware Configuration Register (see Table 82). Default settings after reset are active LOW and level mode. When pulse mode is selected, a pulse of 166 ns is generated when the OR-ed combination of all interrupt bits changes from logic 0 to logic 1.

Bits RESET, RESUME, EOT and SOF are cleared upon reading the Interrupt Register. The endpoint bits (EP0OUT to EP14) are cleared by reading the associated Endpoint Status Register.

Bit BUSTATUS follows the USB bus status exactly, allowing the firmware to get the current bus status when reading the Interrupt Register.

SETUP and OUT token interrupts are generated after ISP1161's DC has acknowledged the associated data packet. In bulk transfer mode, the ISP1161's DC will issue interrupts for every ACK received for an OUT token or transmitted for an IN token.

In isochronous mode, an interrupt is issued upon each packet transaction. The firmware must take care of timing synchronization with the host. This can be done via the Pseudo Start-Of-Frame (PSOF) interrupt, enabled via bit IEP5OF in the Interrupt Enable Register. If a Start-Of-Frame is lost, PSOF interrupts are generated every 1 ms. This allows the firmware to keep data transfer synchronized with the host. After 3 missed SOF events the ISP1161's DC will enter 'suspend' state.

An alternative way of handling isochronous data transfer is to enable both the SOF and the PSOF interrupts and disable the interrupt for each isochronous endpoint.

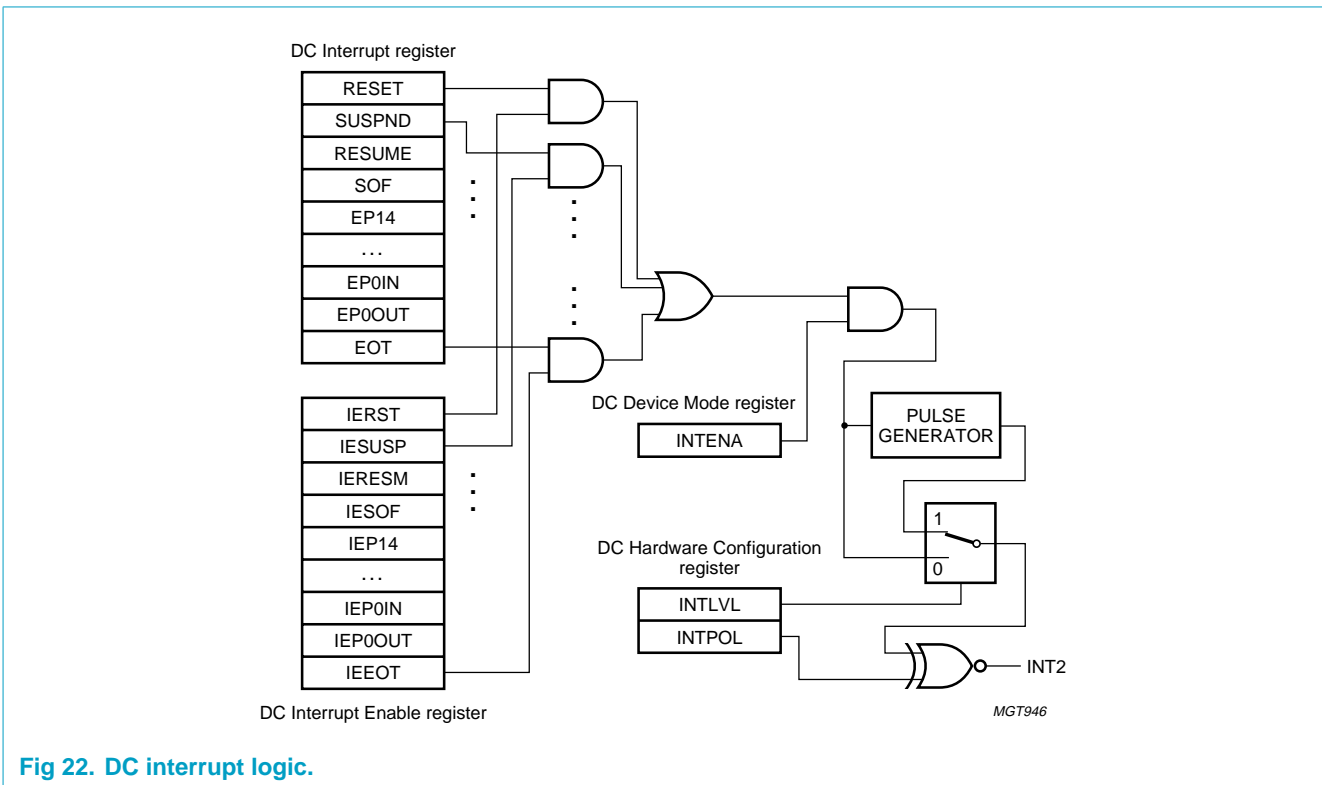

Fig 22. DC interrupt logic.

9. The USB host controller (HC)

9.1 The HC's four USB states

ISP1161's USB HC has four USB states—USB Operational, USB Reset, USB Suspend, and USB Resume—that define the HC's USB signaling and bus states responsibilities. The signals are visible to the HC (software) Driver via ISP1161 USB HC's control registers.

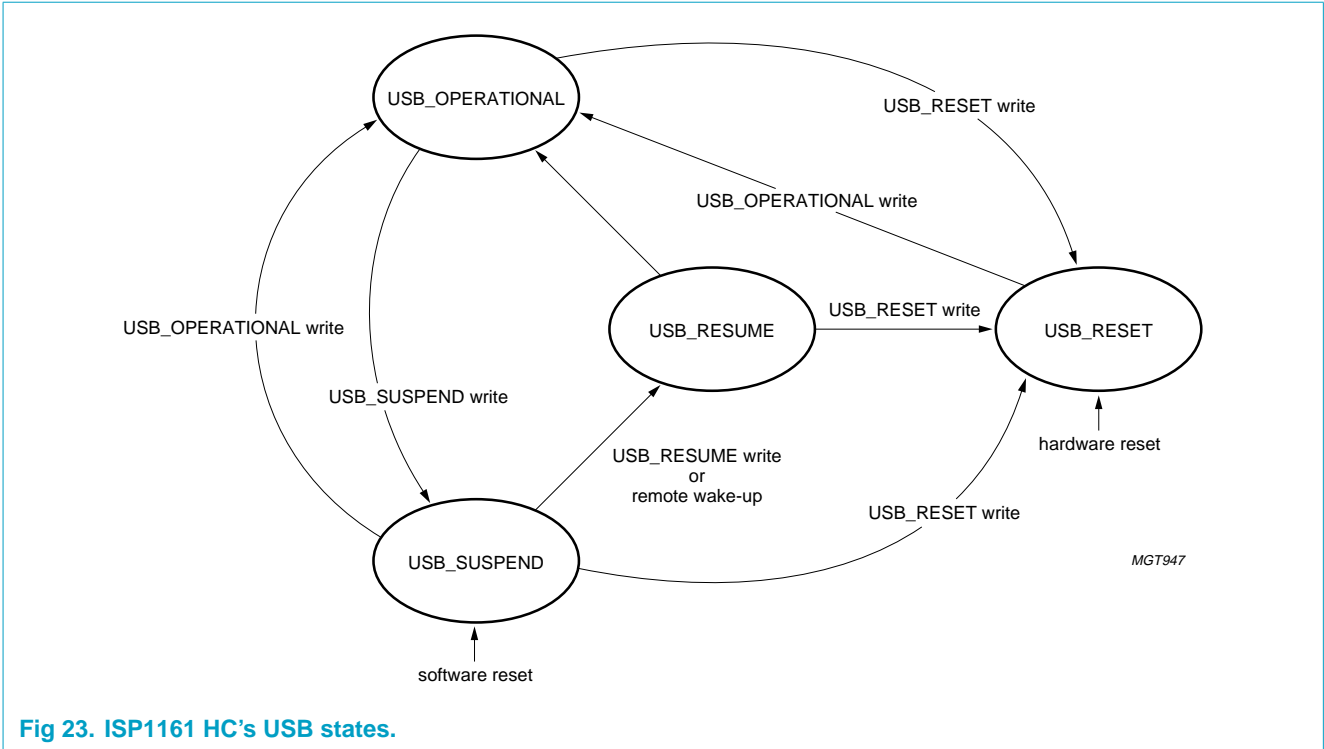

Fig 23. ISP1161 HC's USB states.

The USB states are reflected in the HostControllerFunctionalState field of the HcControl register (01H - Read, 81H - Write), which is located at bits 7 and 6 of the register.

The HC Driver can perform only the USB state transitions shown in [Figure 23](#).

Remark: The Software Reset in [Figure 23](#) is not caused by the HcSoftwareReset command. It is caused by the HostControllerReset field of the HcCommandStatus register (02H - Read, 82H - Write).

9.2 Generating USB traffic

USB traffic can be generated only when the ISP1161 USB HC is under the USB Operational State. Therefore, the HC Driver must set the HostControllerFunctionalState field of the HcControl register before generating USB traffic.

A simplistic flow diagram showing when and how to generate USB traffic is shown in [Figure 24](#). For greater accuracy, refer to both the *Universal Serial Bus Specification Revision 1.1* about the protocol and ISP1161 USB HC's register usage.

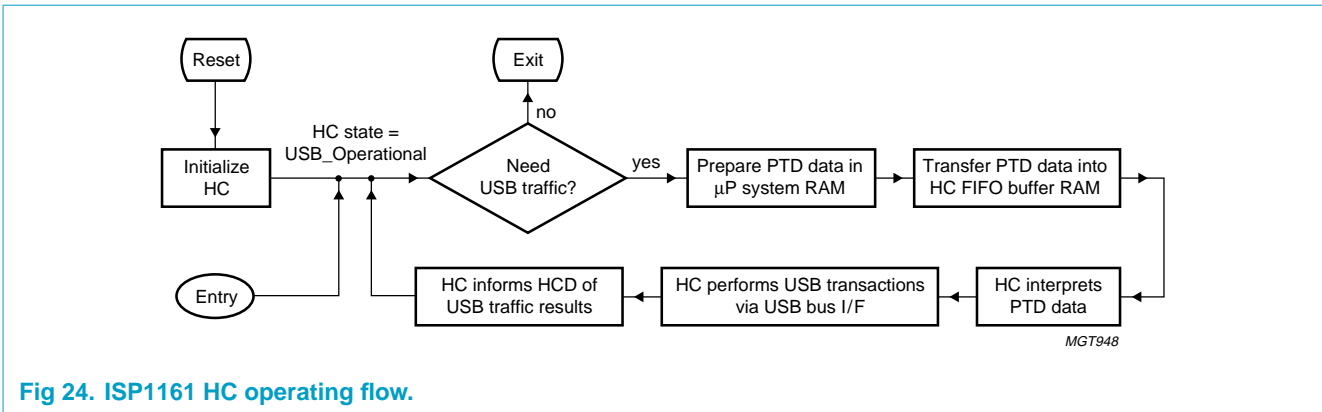

Fig 24. ISP1161 HC operating flow.

- **Reset**

This includes hardware reset by pin $\overline{\text{RESET}}$ and software reset by the HcSoftwareReset command (A9H). The reset function will clear all the HC's internal control registers to their reset status. After reset, the HC Driver must initialize the ISP1161 USB HC by setting some registers.

- **Initialize HC**

It includes:

- Setting the physical size for the HC's internal FIFO buffer RAM by setting the HcITLBufferLength register (2AH - Read, AAH - Write) and the HcATLBufferLength register (2BH - Read, ABH - Write)
- Setting the HcHardwareConfiguration register according to requirements
- Clearing interrupt events, if required
- Enabling interrupt events, if required
- Setting the HcFmInterval register (0DH - Read, 8DH - Write)
- Setting the HC's root hub registers
- Setting the HcControl register to move the HC into USB Operational state

See also [Section 9.5](#).

- **Entry**

The normal entry point. The microprocessor returns to this point when there are HC requests.

- **Need USB Traffic**

USB devices need the HC to generate USB traffic when they have USB traffic requests such as:

- Connecting to or disconnecting from the downstream ports
- Issuing the Resume signal to the HC

To generate USB traffic, the HC Driver must enter the USB transaction loop.

- **Prepare PTD Data in μ P System RAM**

The communication channel between the HC Driver and ISP1161's USB HC is in the form of Philips Transfer Descriptor (PTD) data. The PTD data provides USB traffic information about the commands, status, and USB data packets.

The physical storage media of PTD data for the HC Driver is the microprocessor's system RAM. For ISP1161's USB HC, it is the ISP1161's internal FIFO buffer RAM.

The HC Driver prepares PTD data in the microprocessor's system RAM for transfer to ISP1161's HC internal FIFO buffer RAM.

- **Transfer PTD Data into HC's FIFO Buffer RAM**

When PTD data is ready in the microprocessor's system RAM, the HC Driver must transfer the PTD data from the microprocessor's system RAM into ISP1161's internal FIFO buffer RAM.

- **HC Interprets PTD Data**

The HC determines what USB transactions are required based on the PTD data that have been transferred into the internal FIFO buffer RAM.

- **HC Performs USB Transactions via USB Bus Interface**

The HC performs the USB transactions with the specified USB device endpoint through the USB bus interface.

- **HC Informs HCD the USB Traffic Results**

The USB transaction status and the feedback from the specified USB device endpoint will be put back into the ISP1161's HC internal FIFO buffer RAM in PTD data format. The HC Driver can read back the PTD data from the internal FIFO buffer RAM.

9.3 PTD data structure

The Philips Transfer Descriptor (PTD) data structure provides a communication channel between the HC Driver and the ISP1161's USB HC. PTD data contains information required by the USB traffic. PTD data consists of a PTD followed by its payload data, as shown in [Figure 25](#).

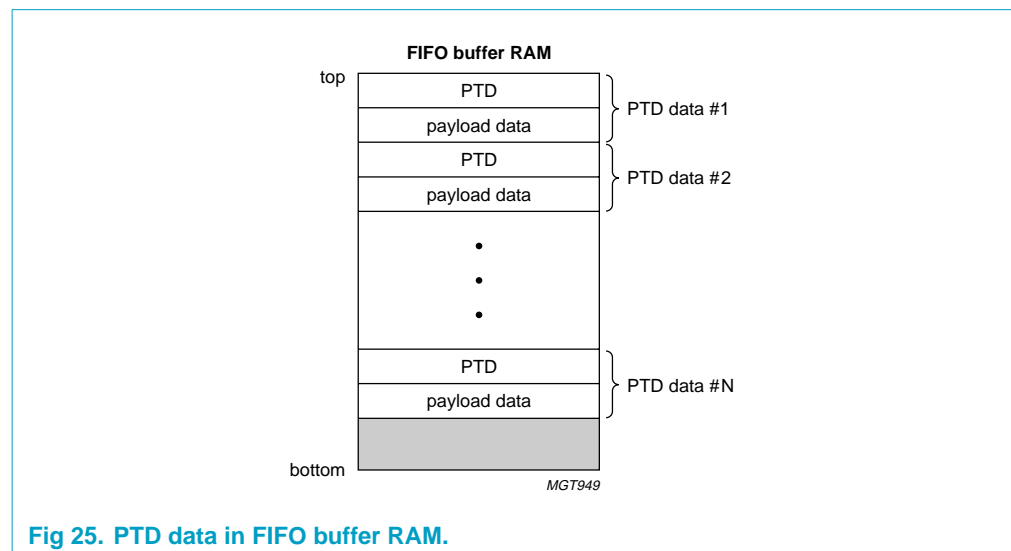

Fig 25. PTD data in FIFO buffer RAM.

The PTD data structure is used by the HC to define a buffer of data that will be moved to or from an endpoint in the USB device. This data buffer is set up for the current frame (1 ms frame) by the firmware, the HC Driver. The payload data for every transfer in the frame must have a PTD as a header to describe the characteristic of the transfer. PTD data is DWORD aligned.

9.3.1 PTD data header definition

The PTD forms the header of the PTD data. It tells the HC the transfer type, where the payload data should go, and the payload data’s actual size. A PTD is an 8-byte data structure that is very important for HC Driver programming.

Table 4: Philips Transfer Descriptor (PTD): bit allocation

Bit	7	6	5	4	3	2	1	0	
Byte 0	ActualBytes[7:0]								
Byte 1	CompletionCode[3:0]			Active		Toggle	ActualBytes[9:8]		
Byte 2	MaxPacketSize[7:0]								
Byte 3	EndpointNumber[3:0]			Last		Speed	MaxPacketSize[9:8]		
Byte 4	TotalBytes[7:0]								
Byte 5					DirectionPID[1:0]		TotalBytes[9:8]		
Byte 6	Format			FunctionAddress[6:0]					
Byte 7									

Table 5: Philips Transfer Descriptor (PTD): bit description

Symbol	Access	Description		
ActualBytes[9:0]	R/W	Contains the number of bytes that were transferred for this PTD		
CompletionCode[3:0]	R/W	0000	NoError General TD or isochronous data packet processing completed with no detected errors.	
		0001	CRC Last data packet from endpoint contained a CRC error.	
		0010	BitStuffing Last data packet from endpoint contained a bit stuffing violation.	
		0011	DataToggleMismatch Last packet from endpoint had data toggle PID that did not match the expected value.	
		0100	Stall TD was moved to the Done queue because the endpoint returned a STALL PID.	
		0101	DeviceNotResponding Device did not respond to token (IN) or did not provide a handshake (OUT).	
		0110	PIDCheckFailure Check bits on PID from endpoint failed on data PID (IN) or handshake (OUT)	
		0111	UnexpectedPID Received PID was not valid when encountered or PID value is not defined.	
		1000	DataOverrun The amount of data returned by the endpoint exceeded either the size of the maximum data packet allowed from the endpoint (found in MaximumPacketSize field of ED) or the remaining buffer size.	
		1001	DataUnderrun The endpoint returned is less than MaximumPacketSize and that amount was not sufficient to fill the specified buffer.	
		1010	reserved	-
		1011	reserved	-
		1100	BufferOverrun During an IN, the HC received data from an endpoint faster than it could be written to system memory.	
1101	BufferUnderrun During an OUT, the HC could not retrieve data from the system memory fast enough to keep up with the USB data rate.			
Active	R/W	Set to logic 1 by firmware to enable the execution of transactions by the HC. When the transaction associated with this descriptor is completed, the HC sets this bit to logic 0, indicating that a transaction for this element should not be executed when it is next encountered in the schedule.		
Toggle	R/W	Used to generate or compare the data PID value (DATA0 or DATA1). It is updated after each successful transmission or reception of a data packet.		
MaxPacketSize[9:0]	R	The maximum number of bytes that can be sent to or received from the endpoint in a single data packet.		
EndpointNumber[3:0]	R	USB address of the endpoint within the function.		
Last(PTD)	R	Last PTD of a list (ITL or ATL). A logic 1 indicates that the PTD is the last PTD.		
(Low)Speed	R	Speed of the endpoint: S = 0 — full speed S = 1 — low speed		

Table 5: Philips Transfer Descriptor (PTD): bit description...continued

Symbol	Access	Description
TotalBytes[9:0]	R	Specifies the total number of bytes to be transferred with this data structure. For Bulk and Control only, this can be greater than MaximumPacketSize.
DirectionPID[1:0]	R	00 SETUP
		01 OUT
		10 IN
		11 reserved
Format	R	The format of this data structure. If this is a Control, Bulk or Interrupt endpoint, then Format = 0. If this is an Isochronous endpoint, then Format = 1.
FunctionAddress[6:0]	R	The is the USB address of the function containing the endpoint that this PTD refers to.

9.4 HC's internal FIFO buffer RAM structure

9.4.1 Partitions

According to the *Universal Serial Bus Specification Rev 1.1*, there are four types of USB data transfers: Control, Bulk, Interrupt and Isochronous.

The HC's internal FIFO buffer RAM is of a physical size of 4 kbytes. This internal FIFO buffer RAM is used for transferring data between the microprocessor and USB peripheral devices. This on-chip buffer RAM can be partitioned into two areas: Acknowledged Transfer List (ATL) buffer and Isochronous (ISO) Transfer List (ITL) buffer. The ITL buffer is a Ping-pong structured FIFO buffer RAM that is used to keep the payload data and their PTD header for Isochronous transfers. The ATL buffer is a non Ping-pong structured FIFO buffer RAM that is used for the other three types of transfers.

For the ITL buffer, it can be further partitioned into ITL0 and ITL1 for the Ping-Pong structure. The ITL0 buffer and ITL1 buffer always have the same size. The microprocessor can put ISO data into either the ITL0 buffer or the ITL1 buffer. When the microprocessor accesses an ITL buffer, the HC can take over another ITL buffer at the same time. This architecture can improve the ISO transfer performance.

The Host Controller Driver can assign the logical size for ATL buffer and ITL buffers at any time, but normally at initialization after power-on reset, by setting the HcATLBufferLength register (2BH - Read, ABH - Write) and HcITLBufferLength register (2AH - Read, AAH - Write), respectively. However, the total length (ATL buffer + ITL buffer) should not exceed 4 kbytes, the maximum RAM size. [Figure 26](#) shows the partitions of the internal FIFO buffer RAM. When assigning buffer RAM sizes, follow this formula:

$$\text{ATL buffer length} + 2 \times (\text{ITL buffer size}) \leq 1000\text{H (that is, 4 kbytes)}$$

where: ITL buffer size = ITL0 buffer length = ITL1 buffer length

The following assignments are examples of legal uses of the internal FIFO buffer RAM:

- ATL buffer length = 800H, ITL buffer length = 400H.
This is the maximum use of the internal FIFO buffer RAM.

- ATL buffer length = 400H, ITL buffer length = 200H.
This is insufficient use of the internal FIFO buffer RAM.
- ATL buffer length = 1000H, ITL buffer length = 0H.
This will use the internal FIFO buffer RAM for only ATL transfers.
- ATL buffer length = 0H, ITL buffer length = 800H.
This will use the internal FIFO buffer RAM for only ISO transfers.

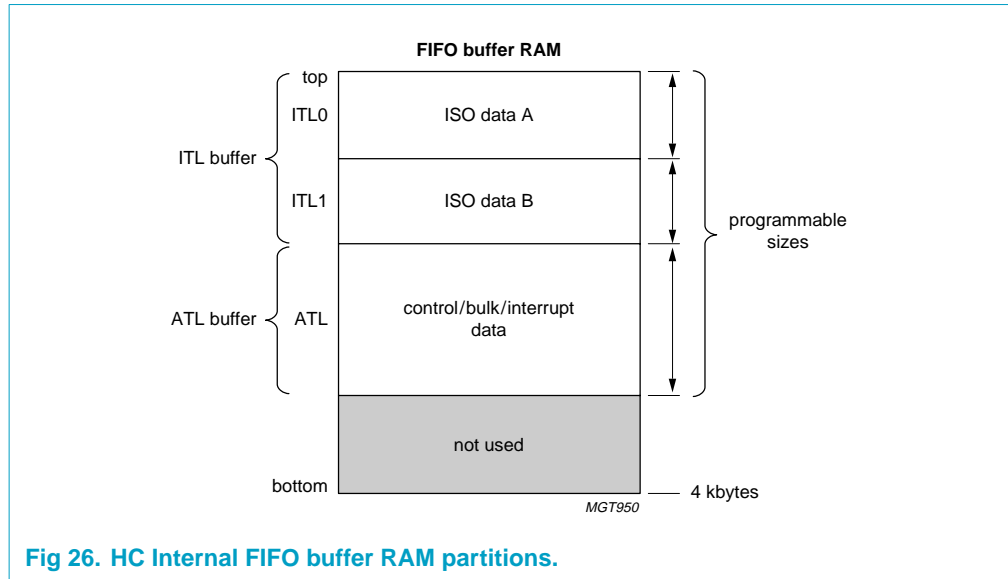

Fig 26. HC Internal FIFO buffer RAM partitions.

The actual requirement for the buffer RAM may not reach the maximum size. You can make your selection based on your application.

The following are some calculations of the ISO_A or ISO_B space for a frame of data: Maximum number of useful data sent during one USB frame is 1280 bytes (20 ISO packets of 64 bytes). Total RAM size needed for this is $20 \times 8 + 1280 = 1440$ bytes.

- Maximum number of packets for different endpoints sent during one USB frame is 150 (150 ISO packets of 1 byte). Total RAM size needed is $150 \times 8 + 150 \times 1 = 1350$ bytes.
- The Ping buffer RAM (ITL0) and the Pong buffer RAM (ITL1) have a maximum size of 2 kbytes each. All data needed for one frame can be stored in the Ping or the Pong buffer RAM.

When the embedded system wants to initiate a transfer to the USB bus, the data needed for one frame is transferred to the ATL buffer or ITL buffer. The microprocessor detects the buffer status through the interrupt routines. When the HcBufferStatus register (2CH - Read only) indicates that buffer is empty, then the microprocessor can write data into the buffer. When the HcBufferStatus register indicates that buffer is full, that is data is ready on the buffer, the microprocessor needs to read data from the buffer.

During every 1 ms, there might be many events to generate interrupt requests to the microprocessor for data transfer or status retrieval. However, each of the interrupt types defined in this specification can be enabled or disabled by setting the HcPIInterruptEnable register bits accordingly.

The data transfer can be done via PIO mode or DMA mode. The data transfer rate can go up to 15 Mbyte/s. In DMA operation, single-cycle or multi-cycle burst modes are supported. For the multi-cycle burst mode, 1, 4, or 8 cycles per burst is supported for ISP1161.

9.4.2 Data organization

PTD data is used for every data transfer between a microprocessor and the USB bus, and the PTD data resides in the buffer RAM. For an OUT or SETUP transfer, the payload data is placed just after the PTD, after which the next PTD is placed. For an IN transfer, some RAM space is reserved for receiving a number of bytes that is equal to the total bytes of the transfer. After this, the next PTD and its payload data are placed (see Figure 27).

Remark: The PTD is defined for both ATL and ITL type data transfer. For ITL, the PTD data should be put into ITL buffer RAM, the ISP1161 takes care of the Ping-Pong action for the ITL buffer RAM access.

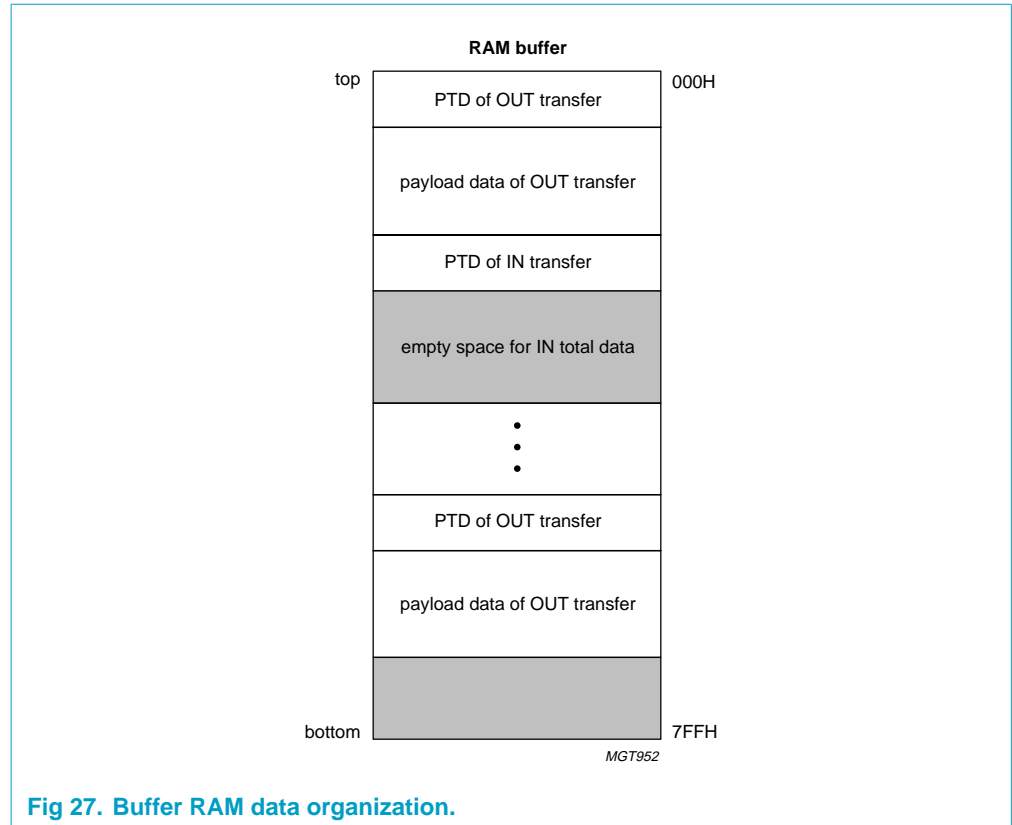

Fig 27. Buffer RAM data organization.

The PTD data (PTD header and its payload data) is a structure of DWORD (double-word or 4-byte) alignment. This means that the memory address is organized in steps of 4 bytes. Therefore, the first byte of every PTD and the first byte of every payload data are located at an address which is a multiple of 4. Figure 28 illustrates an example in which the first payload data is 14 bytes long, meaning that the last byte of the payload data is at the location 15H. The next addresses (16H and 17H) are not multiples of 4. Therefore, the first byte of the next PTD will be located at the next multiple-of-four address, 18H.

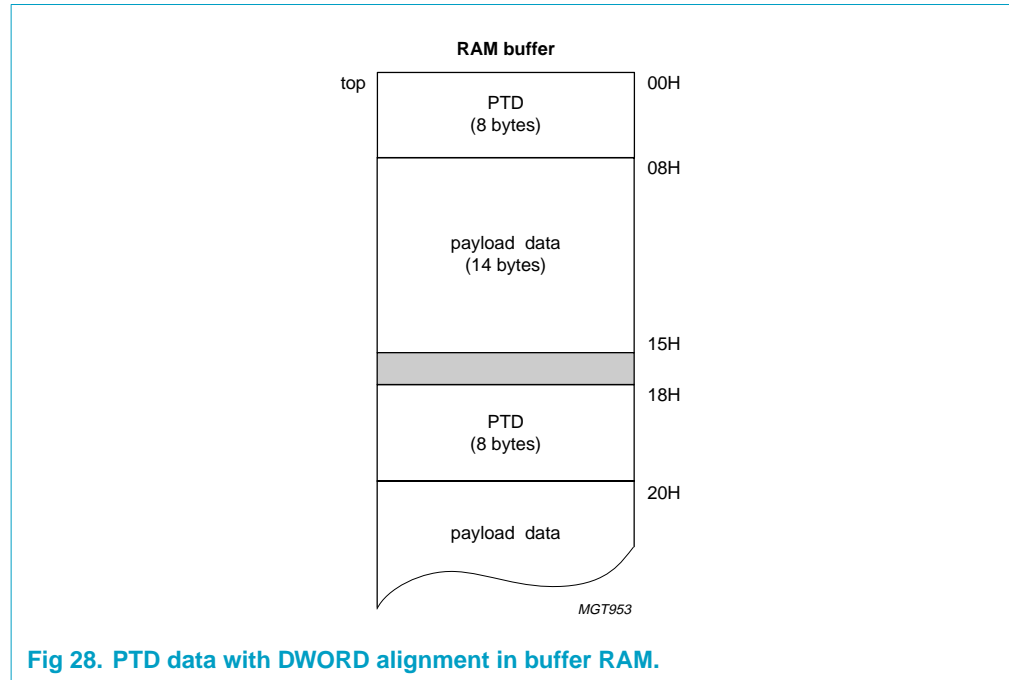

Fig 28. PTD data with DWORD alignment in buffer RAM.

9.4.3 Operation & C Program Example

Figure 29 shows the block diagram for internal FIFO buffer RAM operations by PIO mode. ISP1161 provides one register as the access port for each buffer RAM. For the ITL buffer RAM, the access port is the ITLBufferPort register (40H - Read, C0H - Write). For the ATL buffer RAM, the access port is the ATLBufferPort register (41H - Read, C1H - Write). The buffer RAM is an array of bytes (8 bits) while the access port is a 16-bit register. Therefore, each read/write operation on the port accesses two consecutive memory locations, incrementing the pointer of the internal buffer RAM by two.

The lower byte of the access port register corresponds to the data byte at the even location of the buffer RAM, and the higher byte in the access port register corresponds to the other data byte at the odd location of the buffer RAM. Regardless of the number of data bytes to be transferred, the command code must be issued merely once, and it will be followed by a number of accesses of the data port (see Section 8.4).

When the pointer of the buffer RAM reaches the value of the HcTransferCounter register, an internal EOT signal will be generated to set bit 2, AllEOTInterrupt, of the HcµPInterrupt register and update the HcBufferStatus register, to indicate that the whole data transfer has been completed.

For ITL buffer RAM, every start of frame (SOF) signal (1 ms) will cause toggling between ITL0 and ITL1 but this depends on the buffer status. If both ITL0BufferFull and ITL1BufferFull of the HcBufferStatus register are already logic 1, meaning that both ITL0 and ITL1 buffer RAMs are full, the toggling will not happen. In this case, the microprocessor will always have access to ITL1.

Following is an example of a C program that shows how to write data into the ATL buffer RAM. The total number of data bytes to be transferred is 80 (decimal) which will be set into the HcTransferCounter register as 50H. The data consists of four types of PTD data:

1. The first PTD header (IN) is 8 bytes, followed by 16 bytes of space reserved for its payload data;
2. The second PTD header (IN) is also 8 bytes, followed by 8 bytes of space reserved for its payload data;
3. The third PTD header (OUT) is 8 bytes, followed by 16 bytes of payload data with values beginning from 0H to FH incrementing by 1;
4. The fourth PTD header (OUT) is also 8 bytes, followed by 8 bytes of payload data with values beginning from 0H to EH incrementing by 2.

In all PTD's, we assign device address 5 and endpoint 1. ActualBytes is always zero (0). TotalBytes equals the number of payload data bytes. The following table shows the results after running this program.

Table 6: Run results of the C program example

Observed items	HC not initialized and not under Operational state	HC initialized and under Operational state	Comments
HcPInterrupt Register			
Bit 1 (ATLInt)	0	1	microprocessor must read ATL
Bit 2 (AllEOTInterrupt)	1	1	transfer completed
HcBufferStatus Register			
Bit 2 (ATLBufferFull)	1	1	transfer completed
Bit 5 (ATLBufferDone)	0	1	PTD data processed by HC
USB Traffic on USB Bus	No	Yes	OUT packets can be seen

However, if communication with a peripheral USB device is desired, the device should be connected to the downstream port and pass enumeration.

```
//The example program for writing ATL buffer RAM
#include <conio.h>
#include <stdio.h>
#include <dos.h>

//Define register commands
#define wHcTransferCounter 0x22
#define wHcuPInterrupt 0x24
#define wHcATLBufferLength 0x2b
#define wHcBufferStatus 0x2c

// Define I/O Port Address for HC
#define HcDataPort 0x290
#define HcCmdPort 0x292

//Declare external functions to be used
unsigned int HcRegRead(unsigned int wIndex);
void HcRegWrite(unsigned int wIndex,unsigned int wValue);

void main(void)
{
```

```

unsigned int i;
unsigned int wCount,wData;

// Prepare PTD data to be written into HC ATL buffer RAM:
unsigned int PTDData[0x28]=
{

0x0800,0x1010,0x0810,0x0005, //PTD header for IN token #1

//Reserved space for payload data of IN token #1
0x0000,0x0000,0x0000,0x0000, 0x0000,0x0000,0x0000,0x0000,

0x0800,0x1008,0x0808,0x0005, //PTD header for IN token #2

//Reserved space for payload data of IN token #2
0x0000,0x0000,0x0000,0x0000,

0x0800,0x1010,0x0410,0x0005, //PTD header for OUT token #1

0x0100,0x0302,0x0504,0x0706, //Payload data for OUT token #1
0x0908,0x0b0a,0x0d0c,0x0f0e,

0x0800,0x1808,0x0408,0x0005, //PTD header for OUT token #2

0x0200,0x0604,0x0a08,0x0e0c //Payload data for OUT token #2
};
HcRegWrite(wHcuPInterrupt,0x04); //Clear EOT interrupt bit
//HcRegWrite(wHcITLBufferLength,0x0);
HcRegWrite(wHcATLBufferLength,0x1000); //RAM full use for ATL
//Set the number of bytes to be transferred
HcRegWrite(wHcTransferCounter,0x50);

wCount = 0x28; //Get word count outport
(HcCmdPort,0x00c1); //Command for ATL buffer write

//write 80 (0x50) bytes of data into ATL buffer RAM
for (i=0;i<wCount;i++)
{
    outport(HcDataPort,PTDData[i]);
};

//Check EOT interrupt bit
wData = HcRegRead(wHcuPInterrupt);
printf("\n HC Interrupt Status = %xH.\n",wData);

//Check Buffer status register
wData = HcRegRead(wHcBufferStatus);
printf("\n HC Buffer Status = %xH.\n",wData);
}

//
// Read HC 16-bit registers
//
unsigned int HcRegRead(unsigned int wIndex)
{ unsigned int wValue;

    outport(HcCmdPort,wIndex & 0x7F);
    wValue = inport(HcDataPort);

```

```

return(wValue);
}
//
// Write HC 16-bit registers
//
void HcRegWrite(unsigned int wIndex,unsigned int wValue)
{
outport(HcCmdPort,wIndex | 0x80);
outport(HcDataPort,wValue);
}
    
```

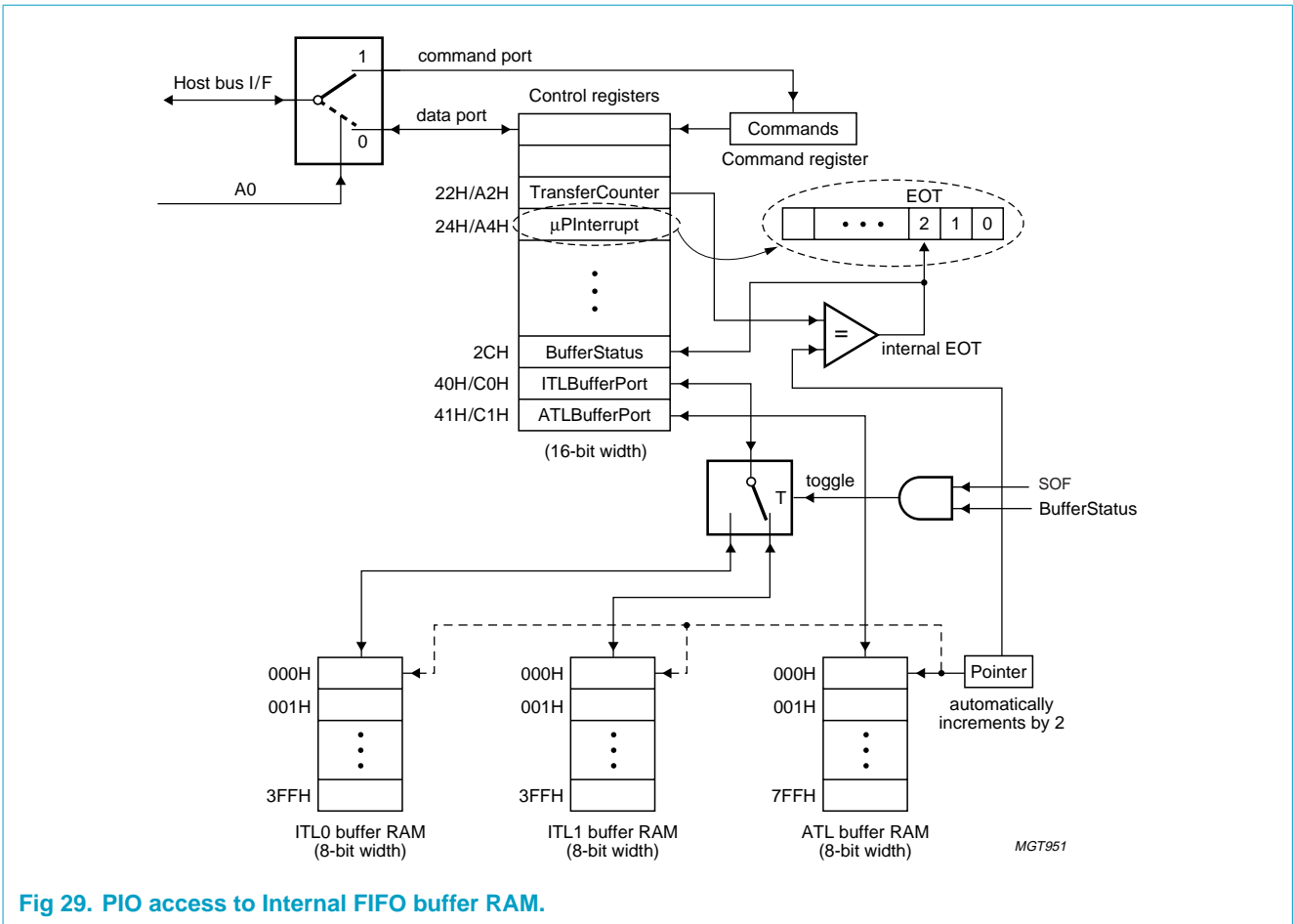

Fig 29. PIO access to Internal FIFO buffer RAM.

9.5 HC's operational model

Upon power up, the HC Driver sets up all operational registers (32-bit). The FSLargestDataPacket field (bits 30 to 16) of the HcFmInterval register (0DH - Read, 8DH - write) and the HcLSThreshold register (11H - Read, 91H - Write) determine the end of the frame for full-speed and low-speed packets. By programming these fields, the effective USB bus usage can be changed. Furthermore, the size of the ITL buffers (HcITLBufferLength, 2AH - Read, AAH - Write) is programmed.

In the case when a USB frame contains both ISO and AT packets, two interrupts will be generated per frame.

One interrupt is issued concurrently with the SOF. This interrupt (the ITLint is set in the HcμPInterrupt register) triggers reading and writing of the ITL by the microprocessor, after which the interrupt is cleared by the microprocessor.

Next the programmable AT Interrupt (the ATLint is set in the HcμPInterrupt Register) is issued, which triggers reading and writing of the ITL by the microprocessor, after which the interrupt is cleared by the microprocessor. If the microprocessor cannot handle the ISO interrupt before the next ISO interrupt, disrupted ISO traffic can result.

To be able to send more than one packet to the same Control or Bulk endpoint in the same frame, an active bit and a 'TotalBytes of transfer' field are introduced (see [Table 5](#)). The active bit is cleared only if all data of the Philips Transfer Descriptor (PTD) are transferred or if a transaction at that endpoint contained a fatal error. If all PTD of the ATL are serviced once and the frame is not over yet, the HC starts looking for a PTD with the active bit still set. If such a PTD is found and there is still enough time in this frame, another transaction is started on the USB bus for this endpoint.

For ISO processing, the Host Controller Driver has also to take care of the BufferStatus register (2CH, Read only) for the ITL buffer RAM operations. After the Host Controller Driver writes ISO data into ITL buffer RAM, the ITL0BufferFull or ITL1BufferFull bit (depends if it is ITL0 or ITL1) will be set to logic 1.

After the HC processes the ISO data in the ITL buffer RAM then the corresponding ITL0BufferDone or ITL1BufferDone bit will automatically be set to logic 1.

The Host Controller Driver can clear the buffer status bits by a read of the ITL buffer RAM, and this must be done within the 1 ms frame from which the ITL0BufferDone or ITL1BufferDone was set. Failure to do so will cause the ISO processing to stop and a power on reset or software reset will have to be applied to the HC, a USB reset to the USB bus must **not** be made.

For example, in the first frame, for the HCD doing a write of ISO-A data into the ITL0 buffer. This will cause the BufferStatus register to show that the ITL0 buffer is full by setting the ITL0BufferFull bit to logic 1. At this stage the Host Controller Driver cannot write ISO data into the ITL0 buffer RAM again.

In the second frame, the Host Controller will process the ISO-A data in the ITL0 buffer. At the same time, the HCD can write ISO-B data into ITL1 buffer. When the next SOF comes (the beginning of the third frame), both the ITL1BufferFull and ITL0BufferDone are automatically set to logic 1. In the third frame the HCD has to read ITL0 buffer at least two bytes (one word) to clear **both** the ITL0BufferFull and ITL0BufferDone bits. If both are not cleared, when the next SOF comes (the beginning of the fourth frame) the ITL0BufferDone bit will be cleared automatically, but the ITL0BufferFull bit remains at logic 1 and the ITL0BufferFull bit will be unable to be cleared. This condition will disable the HCD from writing ISO data into the ITL0 buffer again and ISO processing be unable to be carried on. This also applies to the ITL1 buffer because the ITL0 and ITL1 are Ping-Pong structured buffers. To recover from this state the power on reset or software reset will have to be applied on the HC.

Time domain behavior

In the first example the CPU is fast enough to read back and download a scenario before the next interrupt. Note that on the ISO interrupt of frame N:

- The ISO packet for frame N + 1 will be written;
- The AT packet for frame N + 1 will be written.

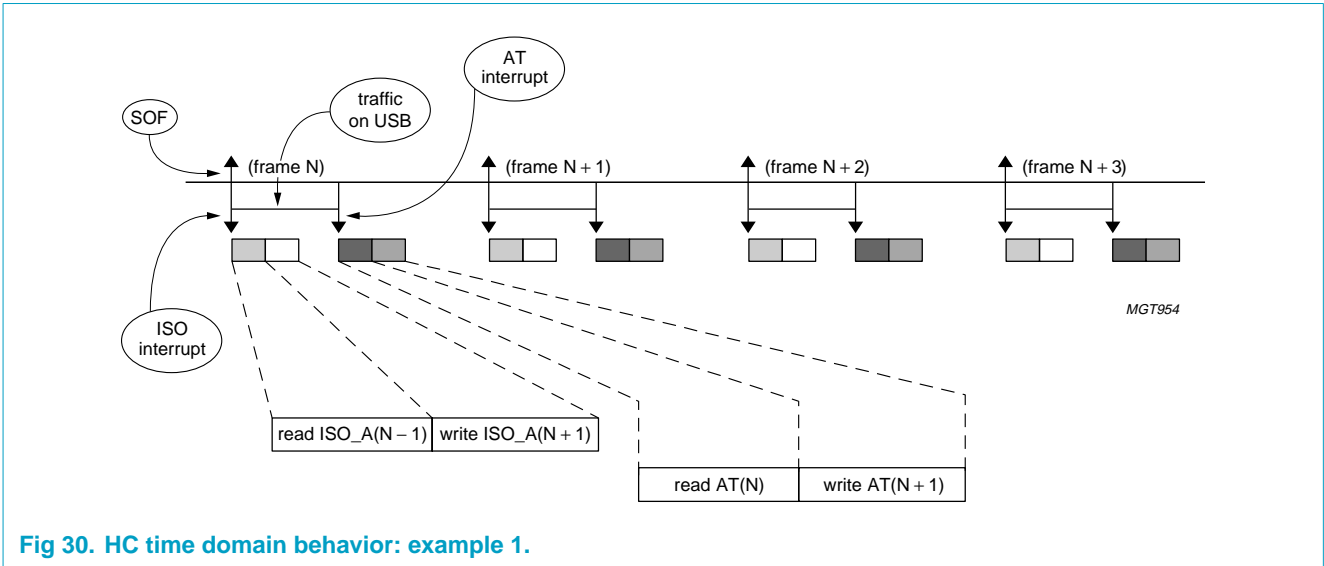

Fig 30. HC time domain behavior: example 1.

In the next example, the microprocessor is still busy transferring the AT data when the ISO interrupt of the next frame (N + 1) is raised. As a result, there will be no AT traffic in frame N + 1. The HC should not raise an AT interrupt in frame N + 1. The AT part is simply postponed until frame N + 2. On the AT N + 2 interrupt the transfer mechanism is back to normal operation. This simple mechanism ensures, among other things, that Control transfers are not dropped systematically from the USB in case of an overloaded microprocessor.

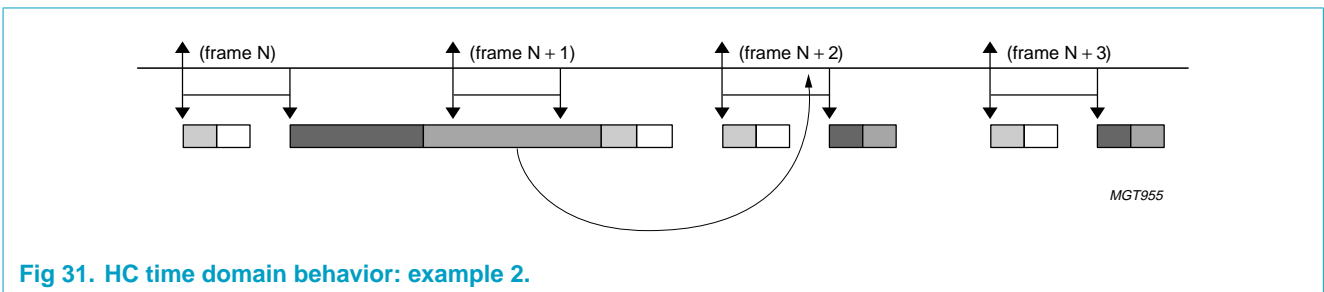

Fig 31. HC time domain behavior: example 2.

In the following example the ISO part is still being written while the Start of Frame (SOF) of the next frame has occurred. This will result in undefined behaviour for the ISO data on the USB bus in frame N + 1 (depending on the exact timing data is corrupted or not). The HC should not raise an AT interrupt in frame N + 1.

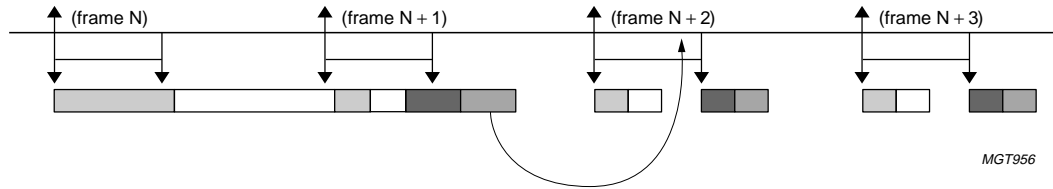

Fig 32. HC time domain behavior: example 3.

Control Transaction Limitations

The different phases of a Control transfer (SETUP, Data and Status) should never be put in the same ATL.

9.6 Microprocessor loading

The maximum amount of data that can be transferred for an endpoint during one frame is 1023 bytes. The number of USB packets that are needed for this batch of data depends on the Maximum Packet Size that is specified.

The HC Driver has to schedule the transactions in a frame. On the other hand, the microprocessor must have the ability to handle the interrupts coming from HC every 1 ms. It must also be able to do the scheduling for the next frame, reading the frame information from and writing the next frame information to the buffer RAM in the time between the end of the current frame and the start of the next frame.

9.7 Internal 15 kΩ pull-down resistors for downstream ports

There are four internal 15 kΩ pull-down resistors built in ISP1161 for the two downstream ports: two resistors for each port. These resistors are software selectable by programming bit 12 of the HcHardwareConfiguration register (20H - Read, A0H - Write). When bit 12 is cleared to logic 0, it means that external 15 kΩ pull-down resistors should be used. Bit 12 is set to logic 1 that indicates the internal built in 15 kΩ pull-down resistors will be used instead of external ones. See [Figure 33](#).

This feature is a cost-saving option. However, the power on reset default value is logic 0. If you want to use the internal resistors, the HC Driver must check this bit status after every reset, because a reset action will clear this bit regardless of it being a hardware reset or a software reset.

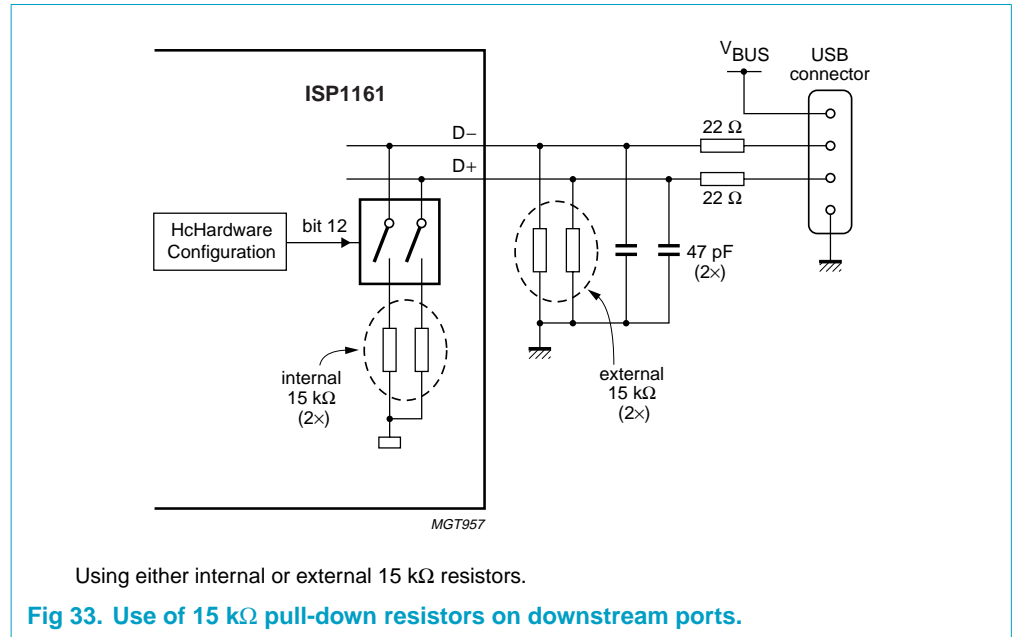

9.8 Overcurrent detection and power switching control

A downstream port provides +5 V power supply to the V_{BUS} . The ISP1161 has built-in hardware functions to monitor the downstream ports loading conditions and control their power switching. These hardware functions are implemented by the internal power switching control circuit and overcurrent detection circuit. $\overline{H_PSW1}$ and $\overline{H_PSW2}$ are power switching control output pins (active LOW, open drain) for downstream port 1 and 2, respectively. $\overline{H_OC1}$ and $\overline{H_OC2}$ are overcurrent detection input pins for downstream ports 1 and 2, respectively. Let $\overline{H_PSWn}$ denote either $\overline{H_PSW1}$ or $\overline{H_PSW2}$ and $\overline{H_OCn}$ denote either $\overline{H_OC1}$ or $\overline{H_OC2}$.

Figure 34 shows the ISP1161 downstream port power management scheme.

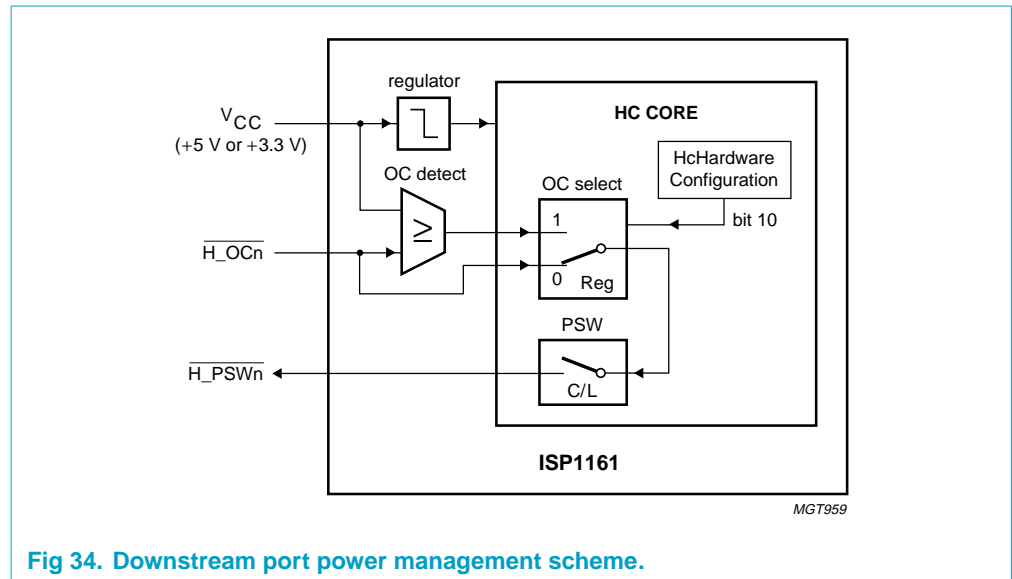

9.8.1 Using internal OC detection circuit

The internal OC detection circuit can be used only when V_{CC} (pin 56) is connected to a +5 V power supply. The HC Driver must set AnalogOCEnable, bit 10 of the HcHardwareConfiguration register, to logic 1.

An application using the internal OC detection circuit and internal 15 k Ω pull-down resistors is shown in [Figure 35](#), where H_DMn denotes either pin H_DM1 or H_DM2, while H_DPN denotes either pin H_DP1 or H_DP2. In this example, the HC Driver must set both AnalogOCEnable and the DownstreamPort15KresistorSel to logic 1. They are bit 10 and bit 12 of the HcHardwareConfiguration register, respectively.

When $\overline{H_OCn}$ detects an overcurrent status on a downstream port, $\overline{H_PSWn}$ will output HIGH, a logic 1 to turn off the +5 V power supply to the downstream port V_{BUS} . When there is no such detection, $\overline{H_PSWn}$ will output LOW, a logic 0 to turn on the +5 V power supply to the downstream port V_{BUS} .

In general applications, we can use a P-channel MOSFET (such as PHP109) as the power switch for V_{BUS} . Connect the +5 V power supply to the drain pole of the P-channel MOSFET, V_{BUS} to the source pole, and $\overline{H_PSWn}$ to the gate pole. We call the voltage drop (ΔV) across the drain and source poles the overcurrent trip voltage. For the internal overcurrent detection circuit, a voltage comparator has been designed-in, with a nominal voltage threshold of 75 mV. Therefore, when the overcurrent trip voltage (ΔV) exceeds the voltage threshold, $\overline{H_PSWn}$ will output a HIGH level, logic 1 to turn off the P-channel MOSFET. If the P-channel MOSFET has a R_{DSon} of 150 m Ω , the overcurrent threshold will be 500 mA. The selection of a P-channel MOSFET with a different R_{DSon} will result in a different overcurrent threshold.

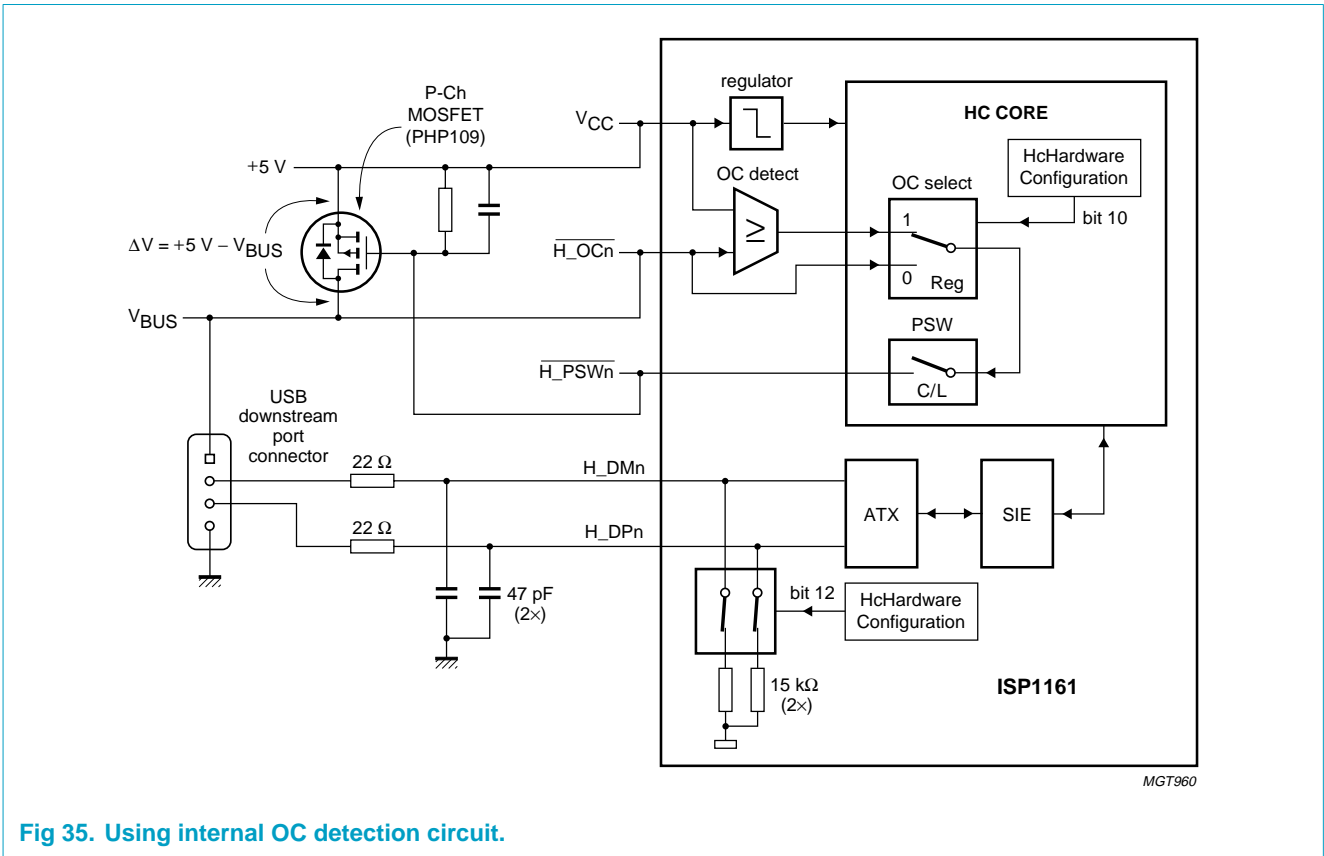

Fig 35. Using internal OC detection circuit.

9.8.2 Using external OC detection circuit

When V_{CC} (pin 56) is connected to the +3.3 V power supply instead of the +5 V power supply, then the internal OC detection circuit cannot be used. An external OC detection circuit must be used instead. Nevertheless, regardless of V_{CC} 's connections, an external OC detection circuit can be used from time to time. To use an external OC detection circuit, AnalogOCEnable, bit 10 of the HcHardwareConfiguration register, should be set to logic 0. By default after reset, this bit is already set to logic 0; therefore, the HC Driver does not need to clear this bit.

Figure 36 shows how to use an external OC detection circuit.

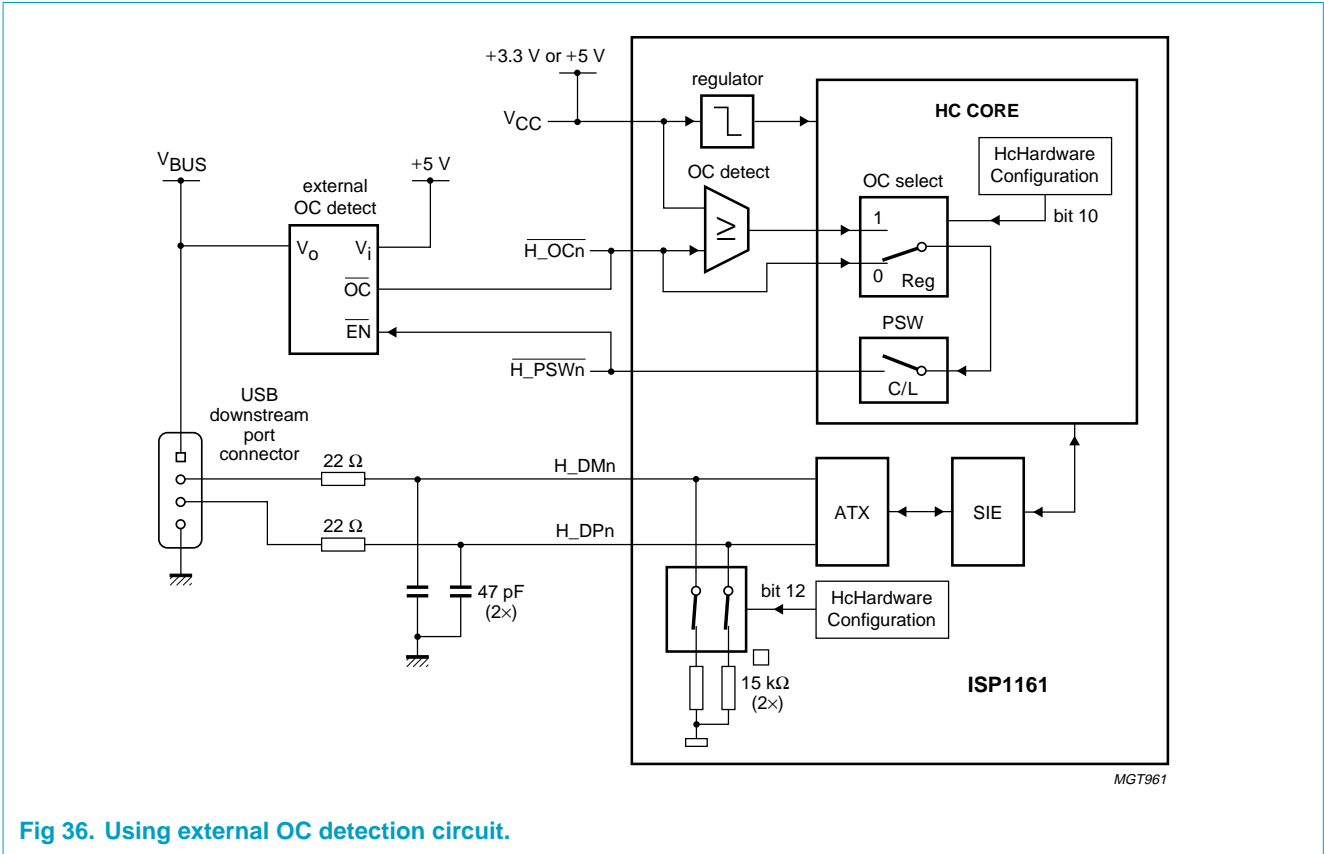

Fig 36. Using external OC detection circuit.

10. Suspend and wakeup (in HC)

10.1 HC suspended state

The HC can be put into suspended state by setting the HcControl register (01H - Read, 81H - Write). See Figure 23 for the HC's flow of USB states changes.

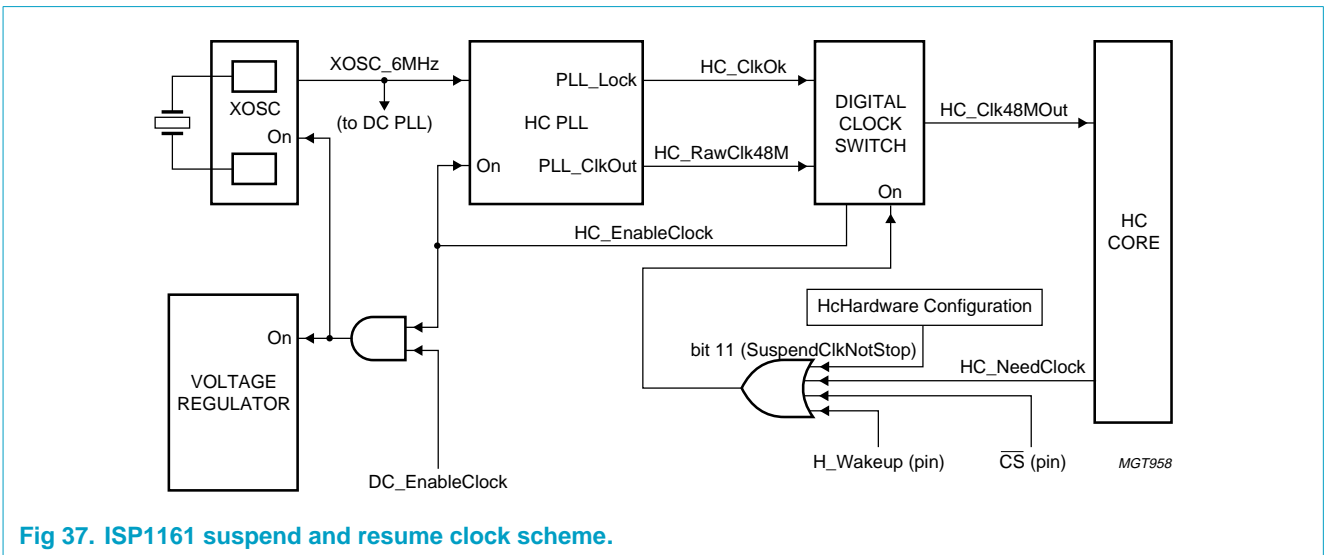

Fig 37. ISP1161 suspend and resume clock scheme.

With the device in a suspended state it will consume considerably less power by turning off the internal 48 MHz clock, PLL and crystal, and setting the internal regulator to power-down mode. The ISP1161 suspend and resume clock scheme is shown in [Figure 37](#).

Remark: ISP1161 can be put into a fully suspended mode only after both the HC and the DC go into the suspended mode, when the crystal can be turned off and the internal regulator can be put into power-down mode.

Pin H_SUSPEND is the sensing output pin for HC's suspended state. When the HC goes into SUSPEND state, this pin will output a HIGH level (logic 1). This pin is cleared to LOW (logic 0) level only when the HC is put into a RESET state or OPERATIONAL state (refer to the HcControl register bits 7 to 6, 01H - Read, 81H - Write). By setting bit 11, SuspendClkNotStop, of the HcHardwareConfiguration register (20H - Read, A0H - Write), you can also define such that when the HC goes into SUSPEND state, its internal clock is stopped or kept running. After HC enters the SUSPEND State for 1.3 ms, the internal clock will be stopped if bit SuspendClkNotStop is logic 0.

10.2 HC wakeup from suspended state

There are three methods to wake up the HC from the USB SUSPEND state: hardware wakeup, software wakeup, and USB bus resume. They are described as follows:

10.2.1 Wakeup by pin H_WAKEUP

Pins H_SUSPEND and H_WAKEUP provide hardware wakeup, a way of remote wakeup control for the HC without the need to access the HC internal registers. H_WAKEUP is an external wakeup control input pin for the HC. After the HC goes into SUSPEND state, it can be woken up by sending a HIGH level pulse to pin H_WAKEUP. This will turn on the HC's internal clock, and set bit 6, ClkReady, of the HcPIInterrupt register (24H - Read, A4H - Write). Under the SUSPEND state, once pin H_WAKEUP goes HIGH, after 160 μ s, the internal clock will be up. After the internal clock is up, it will be kept running at least 1.14 ms depending on the status of pin H_WAKEUP. If pin H_WAKEUP is HIGH, then the internal clock will be kept running. If pin H_WAKEUP is LOW, then the internal clock can be kept running for 1.14 ms only, unless the microprocessor sets the HC into OPERATIONAL state during this time.

10.2.2 Wakeup by pin \overline{CS} (software wakeup)

During the SUSPEND state, an external microprocessor issues the chip select signal through pin \overline{CS} to ISP1161. This method of access to ISP1161 internal registers is a software wakeup.

10.2.3 Wakeup by USB devices

For the USB bus resume, a USB device attached to the root hub port issues a resume signal to the HC through the USB bus, switching the HC from SUSPEND state to RESUME State. This will also set the ResumeDetected bit, bit 3 of the HcInterruptStatus register (03H - Read, 83H - Write).

No matter which method is used to wake up the HC from SUSPEND state, you must enable the corresponding interrupt bits before the HC goes into SUSPEND state so that the microprocessor can receive the correct interrupt request to wake up the HC.

11. The USB device controller (DC)

The Device Controller (DC) in ISP1161 originates from Philips ISP1181 USB Full-Speed Interface Device IC. The functionality is same as ISP1181 in 16-bit bus mode. The command and register sets are also the same. Refer also to the ISP1181 datasheet for a description of the operation of ISP1161's DC. If there is any difference found in ISP1181 and ISP1161 datasheet in terms of the DC's functionality, the ISP1161 datasheet supersedes the content in ISP1181 datasheet.

In general the DC in ISP1161 provides 16 endpoints for USB device implementation. Each endpoint can be allocated an amount of RAM space in the on-chip Ping-Pong Buffer RAM. Note: the Ping-Pong buffer RAM for the DC is independent of the buffer RAM in the HC. When the buffer RAM is full, the DC will transfer the data in the buffer RAM to the USB bus. When the buffer RAM is empty, an interrupt is generated to notify the microprocessor to feed in the data. The transfer of data between the microprocessor and the DC can be done in Parallel I/O (PIO) mode or in DMA mode.

11.1 DC data transfer operation

The following session explains how the DC of ISP1161 handles an IN data transfer and an OUT data transfer. In Device mode, ISP1161 acts as a USB device: an IN data transfer means transfer from ISP1161 to an external USB Host (through the upstream port) and an OUT transfer means transfer from external USB Host to ISP1161.

11.1.1 IN data transfer

- The arrival of the IN token is detected by the SIE by decoding the PID.
- The SIE also checks for the device number and endpoint number and verifies whether they are ok.
- If the endpoint is enabled, the SIE checks the contents of the Endpoint Status register. If the endpoint is full, the contents of the FIFO are sent during the data phase, else a NAK handshake is sent.
- After the data phase, the SIE expects a handshake (ACK) from the host (except for ISO endpoints).
- On receiving the handshake (ACK), the SIE updates the interrupt register contents, which in turn generates an interrupt to the microprocessor. The Last Transaction Register (LTR) status is updated and the buffer is set to zero in the Endpoint Status Register. If it fails to get a handshake, a timeout error is generated and the LTR status is updated accordingly. For ISO endpoints, the interrupt and LTR status are updated as soon as data are sent, since there is no handshake phase.
- On receiving an interrupt, the microprocessor reads the interrupt register. It will know which endpoint has generated the interrupt and reads the contents of the corresponding Endpoint Status register. If the buffer is empty, it fills up the buffer, so that data can be sent by the SIE at the next IN token phase.

11.1.2 OUT data transfer

- The arrival of the OUT token is detected by the SIE by decoding the PID.
- The SIE also checks for the device number and endpoint number and verifies whether they are ok.
- If the endpoint is enabled, the SIE checks the contents of the Endpoint Status register. If the endpoint is empty, the data from USB is stored to FIFO during the data phase, else a NAK handshake is sent.
- After the data phase, the SIE sends a handshake (ACK) to the host (except for ISO endpoints).
- The SIE updates the contents of the interrupt register, which in turn generates an interrupt to the microprocessor. The LTR status is updated and the buffer is set to full in the Endpoint Status Register. For ISO endpoints, interrupt and LTR status are updated as soon as data is received successfully, since there is no handshake phase.
- On receiving interrupt, the microprocessor reads the interrupt register. It will know which endpoint has generated the interrupt and reads the content of the corresponding Endpoint Status register. If the buffer is full, it empties the buffer, so that data can be received by the SIE at the next OUT token phase.

11.2 Device DMA transfer

11.2.1 For OUT endpoint (external USB host to ISP1161's DC)

When the internal DMA handler is enabled and at least one buffer (Ping or Pong) is free, the DREQ2 line is asserted. The external DMA controller then starts negotiating for the bus with ISP1161. As soon as it has access, it asserts the DACK2 line and starts writing data. The burst length is programmable. When the number of bytes equal to the burst length has been written, the DREQ2 line is deasserted. As a result, the DMA controller deasserts the DACK2 line and releases the bus. At that moment the whole cycle restarts for the next burst.

When the buffer is full, the DREQ2 line will be de-asserted and the buffer is validated (which means that it will be sent to the host when the next IN token comes in). When the DMA controller terminates the DMA transfer by asserting EOT, the buffer is also validated (even if it is not full). In Auto-reload mode, the DMA handler will automatically restart by asserting its DREQ2 line as soon as a new buffer is available. If the Auto-reload mode is off, then the DMA handler will be disabled automatically. For the next DMA transfer, the DMA handler must be reenabled.

11.2.2 For IN endpoint (ISP1161's DC to external USB host)

When the internal DMA handler is enabled and at least one buffer is full, the DREQ2 line is asserted. The external DMA controller then starts negotiating for the bus with other parties and as soon as it has access, it asserts the DACK2 line and starts reading the data. The burst length is programmable. When the number of bytes equal to the burst length has been read, the DREQ2 line is deasserted. As a result, the DMA controller deasserts the DACK2 line and releases the bus. At that moment the whole cycle restarts for the next burst. When all data are read, the DREQ2 line will be deasserted and the buffer is cleared (which means that it can be overwritten when a new packet comes in).

When the DMA controller terminates the DMA transfer by asserting EOT and Auto-reload mode is off, the buffer is also cleared (even if not all data are read) and the DMA handler is disabled automatically. For the next DMA transfer, the DMA controller as well as the DMA handler must be re-enabled. However in Auto-reload mode, the DMA handler will automatically restart by reasserting the DREQ2 line, without any loss of data.

11.3 Endpoint descriptions

11.3.1 Endpoints with programmable FIFO size

Each USB device is logically composed of several independent endpoints. An endpoint acts as a terminus of a communication flow between the host and the device. At design time each endpoint is assigned a unique number (endpoint identifier, see [Table 7](#)). The combination of the device address (given by the host during enumeration), the endpoint number and the transfer direction allows each endpoint to be uniquely referenced.

The ISP1161 has 16 endpoints: endpoint 0 (control IN and OUT) plus 14 configurable endpoints, which can be individually defined as interrupt/bulk/isochronous, IN or OUT. Each enabled endpoint has an associated FIFO, which can be accessed either via the parallel I/O interface or via DMA.

11.3.2 Endpoint access

[Table 7](#) lists the endpoint access modes and programmability. All endpoints support I/O mode access. Endpoints 1 to 14 also support DMA access. FIFO DMA access is selected and enabled via bits EPIDX[3:0] and DMAEN of the DMA Configuration Register. A detailed description of the DMA operation is given in [Section 12](#).

Table 7: Endpoint access and programmability

Endpoint identifier	FIFO size (bytes)	Double buffering	I/O mode access	DMA mode access	Endpoint type
0	64 (fixed)	no	yes	no	control OUT ^[1]
0	64 (fixed)	no	yes	no	control IN ^[1]
1	programmable	supported	supported	supported	programmable
2	programmable	supported	supported	supported	programmable
3	programmable	supported	supported	supported	programmable
4	programmable	supported	supported	supported	programmable
5	programmable	supported	supported	supported	programmable
6	programmable	supported	supported	supported	programmable
7	programmable	supported	supported	supported	programmable
8	programmable	supported	supported	supported	programmable
9	programmable	supported	supported	supported	programmable
10	programmable	supported	supported	supported	programmable
11	programmable	supported	supported	supported	programmable
12	programmable	supported	supported	supported	programmable
13	programmable	supported	supported	supported	programmable
14	programmable	supported	supported	supported	programmable

- [1] IN: input for the USB host (ISP1161 transmits); OUT: output from the USB host (ISP1161 receives).
- [2] The data flow direction is determined by bit EPDIR in the Endpoint Configuration Register.
- [3] The total amount of FIFO storage allocated to enabled endpoints must not exceed 2462 bytes.

11.3.3 Endpoint FIFO size

The size of the FIFO determines the maximum packet size that the hardware can support for a given endpoint. Only enabled endpoints are allocated space in the shared FIFO storage, disabled endpoints have zero bytes. [Table 8](#) lists the programmable FIFO sizes.

The following bits in the Endpoint Configuration Register (ECR) affect FIFO allocation:

- Endpoint enable bit (FIFOEN)
- Size bits of an enabled endpoint (FFOSZ[3:0])
- Isochronous bit of an enabled endpoint (FFOISO).

Remark: Register changes that affect the allocation of the shared FIFO storage among endpoints must **not** be made while valid data is present in any FIFO of the enabled endpoints. Such changes will render **all** FIFO contents **undefined**.

Table 8: Programmable FIFO size

FFOSZ[3:0]	Non-isochronous	Isochronous
0000	8 bytes	16 bytes
0001	16 bytes	32 bytes
0010	32 bytes	48 bytes
0011	64 bytes	64 bytes
0100	reserved	96 bytes
0101	reserved	128 bytes
0110	reserved	160 bytes
0111	reserved	192 bytes
1000	reserved	256 bytes
1001	reserved	320 bytes
1010	reserved	384 bytes
1011	reserved	512 bytes
1100	reserved	640 bytes
1101	reserved	768 bytes
1110	reserved	896 bytes
1111	reserved	1023 bytes

Each programmable FIFO can be configured independently via its ECR, but the total physical size of all enabled endpoints (IN plus OUT) must not exceed 2462 bytes (512 bytes for non-isochronous FIFOs).

Table 9 shows an example of a configuration fitting in the maximum available space of 2462 bytes. The total number of logical bytes in the example is 1311. The physical storage capacity used for double buffering is managed by the device hardware and is transparent to the user.

Table 9: Memory configuration example

Physical size (bytes)	Logical size (bytes)	Endpoint description
64	64	control IN (64 byte fixed)
64	64	control OUT (64 byte fixed)
2046	1023	double-buffered 1023-byte isochronous endpoint
16	16	16-byte interrupt OUT
16	16	16-byte interrupt IN
128	64	double-buffered 64-byte bulk OUT
128	64	double-buffered 64-byte bulk IN

11.3.4 Endpoint initialization

In response to the standard USB request Set Interface, the firmware must program all 16 ECRs of the ISP1161 in sequence (see [Table 7](#)), whether the endpoints are enabled or not. The hardware will then automatically allocate FIFO storage space.

If all endpoints have been configured successfully, the firmware must return an empty packet to the control IN endpoint to acknowledge success to the host. If there are errors in the endpoint configuration, the firmware must stall the control IN endpoint.

When reset by hardware or via the USB bus, the ISP1161 DC disables all endpoints and clears all ECRs, except for the control endpoint which is fixed and always enabled.

Endpoint initialization can be done at any time; however, it is valid only after enumeration.

11.3.5 Endpoint I/O mode access

When an endpoint event occurs (a packet is transmitted or received), the associated endpoint interrupt bits (EPn) of the Interrupt Register (IR) will be set by the SIE. The firmware then responds to the interrupt and selects the endpoint for processing.

The endpoint interrupt bit will be cleared by reading the Endpoint Status Register (ESR). The ESR also contains information on the status of the endpoint buffer.

For an OUT (= receive) endpoint, the packet length and packet data can be read from ISP1161 using the Read Buffer command. When the whole packet has been read, the firmware sends a Clear Buffer command to enable the reception of new packets.

For an IN (= transmit) endpoint, the packet length and data to be sent can be written to ISP1161 DC using the Write Buffer command. When the whole packet has been written to the buffer, the firmware sends a Validate Buffer command to enable data transmission to the host.

11.3.6 Special actions on control endpoints

Control endpoints require special firmware actions. The arrival of a SETUP packet flushes the IN buffer and disables the Validate Buffer and Clear Buffer commands for the control IN and OUT endpoints. The microcontroller needs to re-enable these commands by sending an Acknowledge Setup command to **both** control endpoints.

This ensures that the last SETUP packet stays in the buffer and that no packets can be sent back to the host until the microcontroller has explicitly acknowledged that it has seen the SETUP packet.

12. DMA transfer for the Device Controller

Direct Memory Access (DMA) is a method to transfer data from one location to another in a computer system, without intervention of the Central Processor Unit (CPU). Many different implementations of DMA exist. The ISP1161 DC supports two methods:

- **8237 compatible mode:** based on the DMA subsystem of the IBM personal computers (PC, AT and all its successors and clones); this architecture uses the Intel 8237 DMA controller and has separate address spaces for memory and I/O
- **DACK-only mode:** based on the DMA implementation in some embedded RISC processors, which has a single address space for both memory and I/O.

The ISP1161 DC supports DMA transfer for all 14 configurable endpoints (see [Table 7](#)). Only one endpoint at a time can be selected for DMA transfer. The DMA operation of the ISP1161 DC can be interleaved with normal I/O mode access to other endpoints.

The following features are supported:

- Single-cycle or burst transfers (up to 16 bytes per cycle)
- Programmable transfer direction (read or write)
- Multiple End-Of-Transfer (EOT) sources: external pin, internal conditions, short/empty packet
- Programmable signal levels on pins DREQ2, DACK2 and EOT.

12.1 Selecting an endpoint for DMA transfer

The target endpoint for DMA access is selected via bits EPDIX[3:0] in the DMA Configuration Register, as shown in [Table 10](#). The transfer direction (read or write) is automatically set by bit EPDIR in the associated ECR, to match the selected endpoint type (OUT endpoint: read; IN endpoint: write).

Asserting input DACK2 automatically selects the endpoint specified in the DMA Configuration Register, regardless of the current endpoint used for I/O mode access.

Table 10: Endpoint selection for DMA transfer

Endpoint identifier	EPDIX[3:0]	Transfer direction	
		EPDIR = 0	EPDIR = 1
1	0010	OUT: read	IN: write
2	0011	OUT: read	IN: write
3	0100	OUT: read	IN: write
4	0101	OUT: read	IN: write
5	0110	OUT: read	IN: write
6	0111	OUT: read	IN: write
7	1000	OUT: read	IN: write
8	1001	OUT: read	IN: write
9	1010	OUT: read	IN: write
10	1011	OUT: read	IN: write

Table 10: Endpoint selection for DMA transfer...continued

Endpoint identifier	EPIDX[3:0]	Transfer direction	
		EPDIR = 0	EPDIR = 1
11	1100	OUT: read	IN: write
12	1101	OUT: read	IN: write
13	1110	OUT: read	IN: write
14	1111	OUT: read	IN: write

12.2 8237 compatible mode

The 8237 compatible DMA mode is selected by clearing bit DAKOLY in the Hardware Configuration Register (see Table 81). The pin functions for this mode are shown in Table 11.

Table 11: 8237 compatible mode: pin functions

Symbol	Description	I/O	Function
DREQ2	DC's DMA request	O	ISP1161 DC requests a DMA transfer
DACK2	DC's DMA acknowledge	I	DMA controller confirms the transfer
EOT	end of transfer	I	DMA controller terminates the transfer
RD	read strobe	I	instructs ISP1161 DC to put data on the bus
WR	write strobe	I	instructs ISP1161 DC to get data from the bus

The DMA subsystem of an IBM compatible PC is based on the Intel 8237 DMA controller. It operates as a 'fly-by' DMA controller: the data is not stored in the DMA controller, but it is transferred between an I/O port and a memory address. A typical example of ISP1161 DC in 8237 compatible DMA mode is given in Figure 38.

The 8237 has two control signals for each DMA channel: DREQ (DMA Request) and DACK (DMA Acknowledge). General control signals are HRQ (Hold Request), HLDA (Hold Acknowledge) and EOP (End-Of-Process). The bus operation is controlled via MEMR (Memory Read), MEMW (Memory Write), IOR (I/O read) and IOW (I/O write).

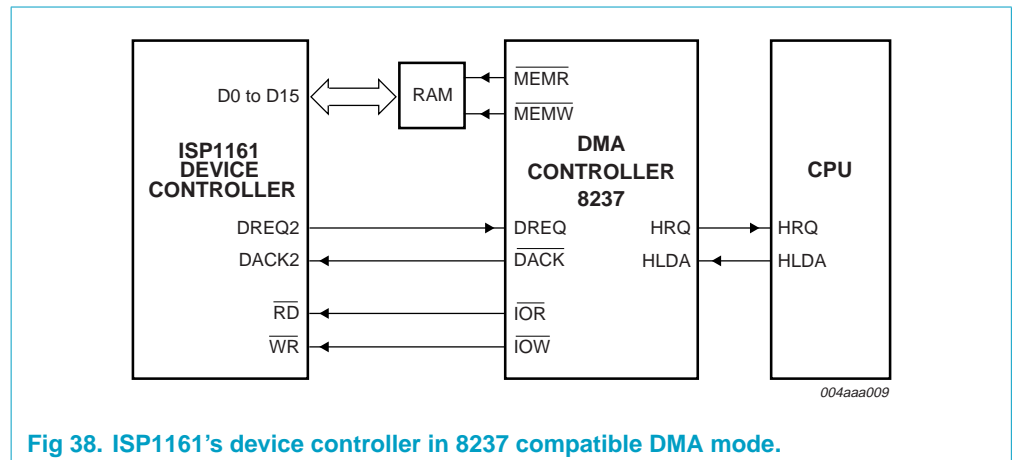

Fig 38. ISP1161's device controller in 8237 compatible DMA mode.

The following example shows the steps which occur in a typical DMA transfer:

1. ISP1161 DC receives a data packet in one of its endpoint FIFOs; the packet must be transferred to memory address 1234H.
2. ISP1161 DC asserts the DREQ2 signal requesting the 8237 for a DMA transfer.
3. The 8237 asks the CPU to release the bus by asserting the HRQ signal.
4. After completing the current instruction cycle, the CPU places the bus control signals ($\overline{\text{MEMR}}$, $\overline{\text{MEMW}}$, $\overline{\text{IOR}}$ and $\overline{\text{IOW}}$) and the address lines in three-state and asserts HLDA to inform the 8237 that it has control of the bus.
5. The 8237 now sets its address lines to 1234H and activates the $\overline{\text{MEMW}}$ and $\overline{\text{IOR}}$ control signals.
6. The 8237 asserts $\overline{\text{DACK}}$ to inform the ISP1161 DC that it will start a DMA transfer.
7. The ISP1161 DC now places the word to be transferred on the data bus lines, because its $\overline{\text{RD}}$ signal was asserted by the 8237.
8. The 8237 waits one DMA clock period and then de-asserts $\overline{\text{MEMW}}$ and $\overline{\text{IOR}}$. This latches and stores the word at the desired memory location. It also informs the ISP1161 DC that the data on the bus lines has been transferred.
9. The ISP1161 DC de-asserts the DREQ2 signal to indicate to the 8237 that DMA is no longer needed. In **Single cycle mode** this is done after each word, in **Burst mode** following the last transferred word of the DMA cycle.
10. The 8237 de-asserts the $\overline{\text{DACK}}$ output indicating that the ISP1161 must stop placing data on the bus.
11. The 8237 places the bus control signals ($\overline{\text{MEMR}}$, $\overline{\text{MEMW}}$, $\overline{\text{IOR}}$ and $\overline{\text{IOW}}$) and the address lines in three-state and de-asserts the HRQ signal, informing the CPU that it has released the bus.
12. The CPU acknowledges control of the bus by de-asserting HLDA. After activating the bus control lines ($\overline{\text{MEMR}}$, $\overline{\text{MEMW}}$, $\overline{\text{IOR}}$ and $\overline{\text{IOW}}$) and the address lines, the CPU resumes the execution of instructions.

For a typical bulk transfer the above process is repeated, once for each byte. After each byte the address register in the DMA controller is incremented and the byte counter is decremented. When using 16-bit DMA the number of transfers is 32 and address incrementing and byte counter decrementing is done by 2 for each word.

12.3 DACK-only mode

The DACK-only DMA mode is selected by setting bit DAKOLY in the Hardware Configuration Register (see [Table 81](#)). The pin functions for this mode are shown in [Table 12](#). A typical example of ISP1161 DC in DACK-only DMA mode is given in [Figure 39](#).

Table 12: DACK-only mode: pin functions

Symbol	Description	I/O	Function
DREQ2	DC's DMA request	O	ISP1161 DC requests a DMA transfer
$\overline{\text{DACK2}}$	DC's DMA acknowledge	I	DMA controller confirms the transfer; also functions as data strobe

Table 12: DACK-only mode: pin functions...continued

Symbol	Description	I/O	Function
EOT	End-Of-Transfer	I	DMA controller terminates the transfer
\overline{RD}	read strobe	I	not used
\overline{WR}	write strobe	I	not used

In DACK-only mode the ISP1161 DC uses the DACK2 signal as a data strobe. Input signals \overline{RD} and \overline{WR} are ignored. This mode is used in CPU systems that have a single address space for memory and I/O access. Such systems have no separate \overline{MEMW} and \overline{MEMR} signals: the \overline{RD} and \overline{WR} signals are also used as memory data strobes.

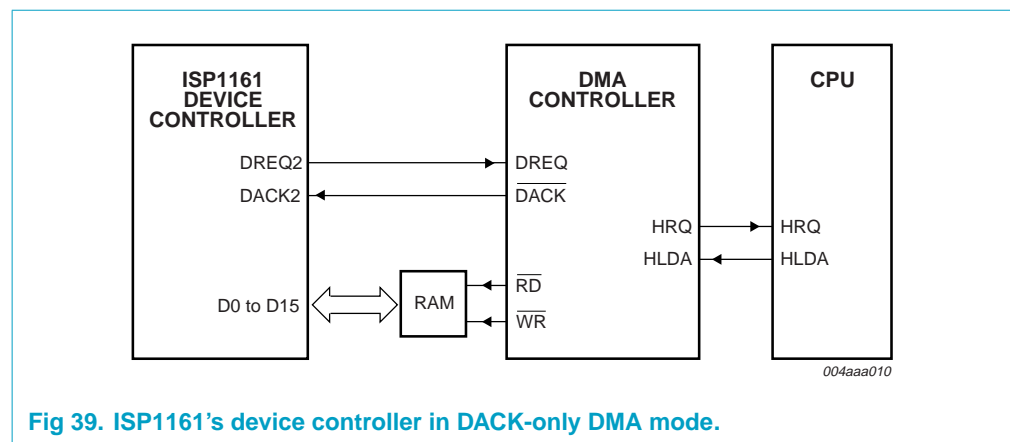

12.4 End-Of-Transfer conditions

12.4.1 Bulk endpoints

A DMA transfer to/from a bulk endpoint can be terminated by any of the following conditions (bit names refer to the DMA Configuration Register, see [Table 85](#)):

- An external End-Of-Transfer signal occurs on input EOT
- The internal DMA Counter Register reaches zero (CNTREN = 1)
- A short/empty packet is received on an enabled OUT endpoint (SHORTP = 1)
- DMA operation is disabled by clearing bit DMAEN.

External EOT: When reading from an OUT endpoint, an external EOT will stop the DMA operation and **clear any remaining data** in the current FIFO. For a double-buffered endpoint the other (inactive) buffer is not affected.

When writing to an IN endpoint, an EOT will stop the DMA operation and the data packet in the FIFO (even if it is smaller than the maximum packet size) will be sent to the USB host at the next IN token.

DMA Counter Register zero: An EOT from the DMA Counter Register is enabled by setting bit CNTREN in the DMA Configuration Register. The ISP1161 has a 16-bit DMA Counter Register, which specifies the number of bytes to be transferred. When

DMA is enabled (DMAEN = 1), the internal DMA counter is loaded with the value from the DMA Counter Register. When the internal counter reaches zero an EOT condition is generated and the DMA operation stops.

Short/empty packet: Normally, the transfer byte count must be set via a control endpoint before any DMA transfer takes place. When a short/empty packet has been enabled as EOT indicator (SHORTP = 1), the transfer size is determined by the presence of a short/empty packet in the data. This mechanism permits the use of a fully autonomous data transfer protocol.

When reading from an OUT endpoint, reception of a short/empty packet at an OUT token will stop the DMA operation after transferring the data bytes of this packet.

When writing to an IN endpoint, a short packet transferred at an IN token will stop the DMA operation after all bytes have been transferred. If the number of bytes in the buffer is zero, ISP1161 DC will automatically send an empty packet.

Table 13: Summary of EOT conditions for a bulk endpoint

EOT condition	OUT endpoint	IN endpoint
EOT input	EOT is active	EOT is active
DMA Counter Register	counter reaches zero	counter reaches zero
Short packet	short packet is received and transferred	counter reaches zero in the middle of the buffer
Empty packet	empty packet is received and transferred	empty packet is automatically appended when needed ^[1]
DMAEN bit in DMA Configuration Register	DMAEN = 0	DMAEN = 0

[1] If short/empty packet EOT is enabled (SHORTP = 1 in DMA Configuration Register) and DMA Counter Register is zero.

12.4.2 Isochronous endpoints

A DMA transfer to/from an isochronous endpoint can be terminated by any of the following conditions (bit names refer to the DMA Configuration Register, see [Table 85](#)):

- An external End-Of-Transfer signal occurs on input EOT
- The internal DMA Counter Register reaches zero (CNTREN = 1)
- An End-Of-Packet (EOP) signal is detected
- DMA operation is disabled by clearing bit DMAEN.

Table 14: Recommended EOT usage for isochronous endpoints

EOT condition	OUT endpoint	IN endpoint
EOT input active	do not use	preferred
DMA Counter Register zero	do not use	preferred
End-Of-Packet	preferred	do not use

13. HC registers

The HC contains a set of on-chip control registers. These registers can be read or written by the Host Controller Driver (HCD). The Control and Status register sets, Frame Counter register sets, and Root Hub register sets are grouped under the category of HC Operational Registers (32 bits). These operational registers are made compatible to OpenHCI (Host Controller Interface) Operational Registers. This makes a provision that the OpenHCI HCD can be ported to ISP1161 easily.

Reserved bits may be defined in future releases of this specification. To ensure interoperability, the HCD that does not use a reserved field must not assume that the reserved field contains logic 0. Furthermore, the HCD must always preserve the values of the reserved field. When a R/W register is modified, the HCD must first read the register, modify the bits desired, and then write the register with the reserved bits still containing the read value. Alternatively, the HCD can maintain an in-memory copy of previously written values that can be modified and then written to the HC register. When a write to set or clear the register is written, bits written to reserved fields must be logic 0.

As shown in [Table 15](#), the offset locations (the commands for reading registers) of these Operational Registers (the 32-bit registers) are similar to those defined in the OHCI specification, however, the addresses are equal to offset DIV 4:

Table 15: HC Control Register summary

Command (Hex)		Register	Width	Functionality
Read	Write			
00	N/A	HcRevision	32	HC Control and Status Registers
01	81	HcControl	32	
02	82	HcCommandStatus	32	
03	83	HcInterruptStatus	32	
04	84	HcInterruptEnable	32	
05	85	HcInterruptDisable	32	
0D	8D	HcFmInterval	32	HC Frame Counter Registers
0E	N/A	HcFmRemaining	32	
0F	N/A	HcFmNumber	32	
11	91	HcLSThreshold	32	HC Root Hub Registers
12	92	HcRhDescriptorA	32	
13	93	HcRhDescriptorB	32	
14	94	HcRhStatus	32	
15	95	HcRhPortStatus[1]	32	
16	96	HcRhPortStatus[2]	32	
20	A0	HcHardwareConfiguration	16	
21	A1	HcDMAConfiguration	16	
22	A2	HcTransferCounter	16	
24	A4	Hc μ PInterrupt	16	
25	A5	Hc μ PInterruptEnable	16	

Table 15: HC Control Register summary...continued

Command (Hex)		Register	Width	Functionality
Read	Write			
27	N/A	HcChipID	16	HC Miscellaneous Registers
28	A8	HcScratch	16	
N/A	A9	HcSoftwareReset	16	
2A	AA	HcITLBufferLength	16	HC Buffer RAM Control Registers
2B	AB	HcATLBufferLength	16	
2C	N/A	HcBufferStatus	16	
2D	N/A	HcReadBackITL0Length	16	
2E	N/A	HcReadBackITL1Length	16	
40	C0	HcITLBufferPort	16	
41	C1	HcATLBufferPort	16	

13.1 HC control and status registers

13.1.1 HcRevision Register

Table 16: HcRevision Register: bit allocation

Bit	31	30	29	28	27	26	25	24
Symbol	reserved							
Reset	00H							
Access	R	R	R	R	R	R	R	R
Bit	23	22	21	20	19	18	17	16
Symbol	reserved							
Reset	00H							
Access	R	R	R	R	R	R	R	R
Bit	15	14	13	12	11	10	9	8
Symbol	reserved							
Reset	00H							
Access	R	R	R	R	R	R	R	R
Bit	7	6	5	4	3	2	1	0
Symbol	REV							
Reset	1	0	1	0	0	0	0	0-
Access	R	R	R	R	R	R	R	R

Table 17: HcRevision Register: bit description

Bit	Symbol	Description
31 to 8	–	Reserved
7 to 0	REV[7:0]	Revision: This read-only field contains the BCD representation of the version of the HCI specification that is implemented by this HC. For example, a value of 11H corresponds to version 1.1. All HC implementations that are compliant with this specification will have a value of 10H.

Code (Hex): 00 — read only

13.1.2 HcControl Register

The HcControl register defines the operating modes for the HC. Most fields are modified only by the HCD, except for HostControllerFunctionalState (HCFS) and RemoteWakeupConnected (RWC).

Table 18: HcControl Register: bit allocation

Bit	31	30	29	28	27	26	25	24
Symbol	reserved							
Reset	00H							
Access	R/W	R/W	R/W	R/W	R/W	R/W	R/W	R/W
Bit	23	22	21	20	19	18	17	16
Symbol	reserved							
Reset	00H							
Access	R/W	R/W	R/W	R/W	R/W	R/W	R/W	R/W
Bit	15	14	13	12	11	10	9	8
Symbol	reserved					RWE	RWC	reserved
Reset	0	0	0	0	0	0	0	0
Access	R/W	R/W	R/W	R/W	R/W	R/W	R/W	R/W
Bit	7	6	5	4	3	2	1	0
Symbol	HCFS[1:0]		reserved					
Reset	0	0	0	0	0	0	0	0
Access	R/W	R/W	R/W	R/W	R/W	R/W	R/W	R/W

Table 19: HcControl Register: bit description

Bit	Symbol	Description
31 to 11	-	reserved
10	RWE	RemoteWakeupEnable: This bit is used by the HCD to enable or disable the remote wakeup feature upon the detection of upstream resume signaling. When this bit is set and the ResumeDetected bit in HcInterruptStatus is set, a remote wakeup is signaled to the host system. Setting this bit has no impact on the generation of hardware interrupt.
9	RWC	RemoteWakeupConnected: This bit indicates whether the HC supports remote wakeup signaling. If remote wakeup is supported and used by the system, it is the responsibility of system firmware to set this bit during POST. The HC clears the bit upon a hardware reset but does not alter it upon a software reset. Remote wakeup signaling of the host system is host-bus-specific and is not described in this specification.
8	-	reserved
7 to 6	HCFS	HostControllerFunctionalState for USB: 00B — USBRESET 01B — USBRESUME 10B — USBOPERATIONAL 11B — USBSUSPEND A transition to USBOPERATIONAL from another state causes start-of-frame (SOF) generation to begin 1 ms later. The HCD may determine whether the HC has begun sending SOFs by reading the StartofFrame field of HcInterruptStatus. This field may be changed by the HC only when in the USBSUSPEND state. The HC may move from the USBSUSPEND state to the USBRESUME state after detecting the resume signaling from a downstream port. The HC enters USBSUSPEND after a software reset; it enters USBRESET after a hardware reset. The latter also resets the Root Hub and asserts subsequent reset signaling to downstream ports.
5 to 0	-	reserved

Code (Hex): 01 — read

Code (Hex): 81 — write

13.1.3 HcCommandStatus Register

The HcCommandStatus register is used by the HC to receive commands issued by the HCD, and it also reflects the HC's current status. To the HCD, it appears to be a 'write to set' register. The HC must ensure that bits written as logic 1 become set in the register while bits written as logic 0 remain unchanged in the register. The HCD may issue multiple distinct commands to the HC without concern for corrupting previously issued commands. The HCD has normal read access to all bits.

The SchedulingOverrunCount field indicates the number of frames with which the HC has detected the scheduling overrun error. This occurs when the Periodic list does not complete before EOF. When a scheduling overrun error is detected, the HC increments the counter and sets the SchedulingOverrun field in the HcInterruptStatus register.

Table 20: HcCommandStatus Register: bit allocation

Bit	31	30	29	28	27	26	25	24	
Symbol	reserved								
Reset	00H								
Access	R								
Bit	23	22	21	20	19	18	17	16	
Symbol	reserved						SOC[1:0]		
Reset	0	0	0	0	0	0	0	0	
Access	R						R		
Bit	15	14	13	12	11	10	9	8	
Symbol	reserved								
Reset	00H								
Access	R/W								
Bit	7	6	5	4	3	2	1	0	
Symbol	reserved							HCR	
Reset	0	0	0	0	0	0	0	0	
Access	R/W								

Table 21: HcCommandStatus Register: bit description

Bit	Symbol	Description
31 to 18	-	reserved
17 to 16	SOC[1:0]	SchedulingOverrunCount: The field is incremented on each scheduling overrun error. It is initialized to 00B and wraps around at 11B. It will be incremented when a scheduling overrun is detected even if SchedulingOverrun in HcInterruptStatus has already been set. This is used by HCD to monitor any persistent scheduling problems.
15 to 1	-	reserved
0	HCR	HostControllerReset: This bit is set by HCD to initiate a software reset of HC. Regardless of the functional state of HC, it moves to the USBSUSPEND state in which most of the operational registers are reset except those stated otherwise; e.g., the InterruptRouting field of HcControl, and no Host bus accesses are allowed. This bit is cleared by HC upon the completion of the reset operation. The reset operation must be completed within 10 s. This bit, when set, should not cause a reset to the Root Hub and no subsequent reset signaling should be asserted to its downstream ports.

Code (Hex): 02 — read

Code (Hex): 82 — write

13.1.4 HcInterruptStatus Register

This register provides the status of the events that cause hardware interrupts. When an event occurs, the HC sets the corresponding bit in this register. When a bit becomes set, a hardware interrupt is generated if the interrupt is enabled in the HcInterruptEnable register (see [Section 13.1.5](#)) and the MasterInterruptEnable bit is set. The HCD may clear specific bits in this register by writing logic1 to the bit positions to be cleared. The HCD may not set any of these bits. The HC will not clear the bit.

Table 22: HcInterruptStatus Register: bit allocation

Bit	31	30	29	28	27	26	25	24
Symbol	reserved							
Reset	00H							
Access	R/W							
Bit	23	22	21	20	19	18	17	16
Symbol	reserved							
Reset	00H							
Access	R/W							
Bit	15	14	13	12	11	10	9	8
Symbol	reserved							
Reset	00H							
Access	R/W							
Bit	7	6	5	4	3	2	1	0
Symbol	reserved	RHSC	FNO	UE	RD	SF	reserved	SO
Reset	0	0	0	0	0	0	0	0
Access	R/W							

Table 23: HcInterruptStatus Register: bit description

Bit	Symbol	Description
31 to 8		reserved
7	reserved	–
6	RHSC	RootHubStatusChange: This bit is set when the content of HcRhStatus or the content of any of HcRhPortStatus[NumberOfDownstreamPort] has changed.
5	FNO	FrameNumberOverflow: This bit is set when the MSB of HcFmNumber (bit 15) changes value, from logic 0 to 1 or from logic 1 to 0.
4	UE	UnrecoverableError: This bit is set when the HC detects a system error not related to USB. The HC should not proceed with any processing nor signaling before the system error has been corrected. The HCD clears this bit after HC has been reset. PHCI: Always set to logic 0.
3	RD	ResumeDetected: This bit is set when the HC detects that a device on the USB is asserting resume signaling. It is the transition from no resume signaling to resume signaling causing this bit to be set. This bit is not set when HCD sets the USBRESUME state.
2	SF	StartOfFrame: At the start of each frame, this bit is set by the HC and an SOF generated.
1	-	reserved
0	SO	SchedulingOverrun: This bit is set when USB schedules for current frame overruns. A scheduling overrun will also cause the SchedulingOverrunCount of HcCommandStatus to be incremented.

Code (Hex): 03 — read

Code (Hex): 83 — write

13.1.5 HcInterruptEnable Register

Each enable bit in the HcInterruptEnable register corresponds to an associated interrupt bit in the HcInterruptStatus register. The HcInterruptEnable register is used to control which events generate a hardware interrupt. When these three conditions occur:

- A bit is set in the HcInterruptStatus register
- The corresponding bit in the HcInterruptEnable register is set
- The MasterInterruptEnable bit is set
- then a hardware interrupt is requested on the host bus.

Writing a logic1 to a bit in this register sets the corresponding bit, whereas writing a logic 0 to a bit in this register leaves the corresponding bit unchanged. On a read, the current value of this register is returned.

Table 24: HcInterruptEnable Register: bit allocation

Bit	31	30	29	28	27	26	25	24
Symbol	MIE	reserved						
Reset	0	0	0	0	0	0	0	0
Access	R/W							
Bit	23	22	21	20	19	18	17	16
Symbol	reserved							
Reset	00H							
Access	R/W							
Bit	15	14	13	12	11	10	9	8
Symbol	reserved							
Reset	00H							
Access	R/W							
Bit	7	6	5	4	3	2	1	0
Symbol	reserved	RHSC	FNO	UE	RD	SF	reserved	SO
Reset	0	0	0	0	0	0	0	0
Access	R/W							

Table 25: HcInterruptEnable Register: bit description

Bit	Symbol	Description
31	MIE	MasterInterruptEnable by the HCD: A logic 0 is ignored by the HC. A logic 1 enables interrupt generation by events specified in other bits of this register.
30 to 8	-	reserved
7	-	reserved
6	RHSC	0 — ignore 1 — enable interrupt generation due to Root Hub Status Change
5	FNO	0 — ignore 1 — enable interrupt generation due to frame Number Overflow
4	UE	0 — ignore 1 — enable interrupt generation due to Unrecoverable Error
3	RD	0 — ignore 1 — enable interrupt generation due to Resume Detect
2	SF	0 — ignore 1 — enable interrupt generation due to Start of frame
1	-	reserved
0	SO	0 — ignore 1 — enable interrupt generation due to Scheduling Overrun

Code (Hex): 04 — read

Code (Hex): 84 — write

13.1.6 HcInterruptDisable Register

Each disable bit in the HcInterruptDisable register corresponds to an associated interrupt bit in the HcInterruptStatus register. The HcInterruptDisable register is coupled with the HcInterruptEnable register. Thus, writing a logic 1 to a bit in this register clears the corresponding bit in the HcInterruptEnable register, whereas writing a logic 0 to a bit in this register leaves the corresponding bit in the HcInterruptEnable register unchanged. On a read, the current value of the HcInterruptEnable register is returned.

Table 26: HcInterruptDisable Register: bit allocation

Bit	31	30	29	28	27	26	25	24
Symbol	MIE	reserved						
Reset	0	0	0	0	0	0	0	0
Access	R/W							
Bit	23	22	21	20	19	18	17	16
Symbol	reserved							
Reset	00H							
Access	R/W							
Bit	15	14	13	12	11	10	9	8
Symbol	reserved							
Reset	00H							
Access	R/W							
Bit	7	6	5	4	3	2	1	0
Symbol	reserved	RHSC	FNO	UE	RD	SF	reserved	SO
Reset	0	0	0	0	0	0	0	0
Access	R/W							

Table 27: HcInterruptDisable Register: bit description

Bit	Symbol	Description
31	MIE	A logic 0 is ignored by the HC. A logic 1 disables interrupt generation due to events specified in other bits of this register. This field is set after a hardware or software reset.
30 to 8	-	reserved
7	-	reserved
6	RHSC	0 — ignore 1 — disable interrupt generation due to Root Hub Status Change

Table 27: HcInterruptDisable Register: bit description...continued

Bit	Symbol	Description
5	FNO	0 — ignore 1 — disable interrupt generation due to frame Number Overflow
4	UE	0 — ignore 1 — disable interrupt generation due to Unrecoverable Error
3	RD	0 — ignore 1 — disable interrupt generation due to Resume Detect
2	SF	0 — ignore 1 — disable interrupt generation due to Start of frame
1	-	reserved
0	SO	0 — ignore 1 — disable interrupt generation due to Scheduling Overrun

Code (Hex): 05 — read

Code (Hex): 85 — write

13.2 HC frame counter registers

13.2.1 HcFmInterval Register

The HcFmInterval register contains a 14-bit value which indicates the bit time interval in a frame (that is, between two consecutive SOFs), and a 15-bit value indicating the full-speed maximum packet size that the HC may transmit or receive without causing a scheduling overrun. The HCD may carry out minor adjustments on the FrameInterval by writing a new value over the present one at each SOF. This provides the programmability necessary for the HC to synchronize with an external clocking resource and to adjust any unknown local clock offset.

Table 28: HcFmInterval Register: bit allocation

Bit	31	30	29	28	27	26	25	24
Symbol	FIT		FSMPS[14:8]					
Reset	0	0	0	0	0	0	0	0
Access	R/W		R/W					
Bit	23	22	21	20	19	18	17	16
Symbol	FSMPS[7:0]							
Reset	0	0	0	0	0	0	0	0
Access	R/W							
Bit	15	14	13	12	11	10	9	8
Symbol	reserved		FI[13:8]					
Reset	0	0	1	0	1	1	1	0
Access	R/W		R/W					
Bit	7	6	5	4	3	2	1	0
Symbol	FI[7:0]							
Reset	1	1	0	1	1	1	1	1
Access	R/W							

Table 29: HcFmInterval Register: bit description

Bit	Symbol	Description
31	FIT	FrameIntervalToggle: The HCD toggles this bit whenever it loads a new value to FrameInterval.
30 to 16	FSMPS [14:0]	FSLargestDataPacket: Specifies a value which is loaded into the Largest Data Packet Counter at the beginning of each frame. The counter value represents the largest amount of data in bits which can be sent or received by the HC in a single transaction at any given time without causing a scheduling overrun. The field value is calculated by the HCD.
15 to 14	-	reserved
13 to 0	FI[13:0]	FrameInterval: Specifies the interval between two consecutive SOFs in bit times. The nominal value is set to be 11999. The HCD must store the current value of this field before resetting the HC. By setting the HostControllerReset bit 0 field of HcCommandStatus register will cause the HC to reset this field to its nominal value. HCD may choose to restore the stored value upon completing the Reset sequence.

Code (Hex): 0D — read

Code (Hex): 8D — write

13.2.2 HcFmRemaining Register

The HcFmRemaining register is a 14-bit down counter showing the bit time remaining in the current frame.

Table 30: HcFmRemaining Register: bit allocation

Bit	31	30	29	28	27	26	25	24
Symbol	FRT	reserved						
Reset	0	0	0	0	0	0	0	0
Access	R	R						
Bit	23	22	21	20	19	18	17	16
Symbol	reserved							
Reset	00H							
Access	R							
Bit	15	14	13	12	11	10	9	8
Symbol	reserved		FR[13:8]					
Reset	0	0	0	0	0	0	0	0
Access	R		R					
Bit	7	6	5	4	3	2	1	0
Symbol	FR[7:0]							
Reset	0	0	0	0	0	0	0	0
Access	R							

Table 31: HcFmRemaining Register: bit description

Bit	Symbol	Description
31	FRT	FrameRemainingToggle: This bit is loaded from the FrameIntervalToggle field of HcFmInterval whenever FrameRemaining reaches 0. This bit is used by the Host Controller Driver (HCD) for synchronization between FrameInterval and FrameRemaining.
30 to 14	-	reserved
13 to 0	FR[13:0]	FrameRemaining: This counter is decremented at each bit time. When it reaches zero, it is reset by loading the FrameInterval value specified in HcFmInterval at the next bit time boundary. When entering the USBOPERATIONAL state, the HC reloads it with the content of the FrameInterval part of the HcFmInterval register and uses the updated value from the next SOF.

Code (Hex): 0E — read

13.2.3 HcFmNumber Register

The HcFmNumber register is a 16-bit counter. It provides a timing reference for events happening in the HC and the HCD. The HCD may use the 16-bit value specified in this register and generate a 32-bit frame number without requiring frequent access to the register.

Table 32: HcFmNumber Register: bit allocation

Bit	31	30	29	28	27	26	25	24
Symbol	reserved							
Reset	00H							
Access	R							
Bit	23	22	21	20	19	18	17	16
Symbol	reserved							
Reset	00H							
Access	R							
Bit	15	14	13	12	11	10	9	8
Symbol	FN[15:8]							
Reset	0	0	0	0	0	0	0	0
Access	R							
Bit	7	6	5	4	3	2	1	0
Symbol	FN[7:0]							
Reset	0	0	0	0	0	0	0	0
Access	R							

Table 33: HcFmNumber Register: bit description

Bit	Symbol	Description
31 to 16	–	reserved
15 to 0	FN[15:0]	FrameNumber: This is incremented when HcFmRemaining is reloaded. It will be rolled over to 0H after FFFFH. When the USBOPERATIONAL state is entered, this will be incremented automatically. HC will set the StartofFrame in HcInterruptStatus.

Code (Hex): 0F — read

13.2.4 HcLSThreshold Register

The HcLSThreshold register contains an 11-bit value used by the HC to determine whether to commit to the transfer of a maximum of 8-byte LS packet before EOF. Neither the HC nor the HCD is allowed to change this value.

Table 34: HcLSThreshold Register: bit allocation

Bit	31	30	29	28	27	26	25	24
Symbol	reserved							
Reset	00H							
Access	R/W							
Bit	23	22	21	20	19	18	17	16
Symbol	reserved							
Reset	00H							
Access	R/W							
Bit	15	14	13	12	11	10	9	8
Symbol	reserved					LST[10:8]		
Reset	0	0	0	0	0	1	1	0
Access	R/W							
Bit	7	6	5	4	3	2	1	0
Symbol	LST[7:0]							
Reset	0	0	1	0	1	0	0	0
Access	R/W							

Table 35: HcLSThreshold Register: bit description

Bit	Symbol	Description
31 to 16	–	reserved
15 to 11	–	reserved
10 to 0	LST[10:0]	LSThreshold: Contains a value that is compared to the FrameRemaining field before a low-speed transaction is initiated. The transaction is started only if FrameRemaining ≥ this field. The value is calculated by the HCD, which considers transmission and setup overhead.

Code (Hex): 11 — read

Code (Hex): 91 — write

13.3 HC Root Hub registers

All registers included in this partition are dedicated to the USB Root Hub, which is an integral part of the HC although it is a functionally separate entity. The Host Controller Driver (HCD) emulates USB-D accesses to the Root Hub via a register interface. The HCD maintains many USB-defined hub features that are not required to be supported in hardware. For example, the Hub's Device, Configuration, Interface, and Endpoint Descriptors are maintained only in the HCD as well as some static fields of the Class Descriptor. The HCD also maintains and decodes the Root Hub's device address as well as other trivial operations that they are better suited to software than to hardware.

The Root Hub registers are developed to maintain the similarity of bit organization and operation to typical hubs found in the system.

Four registers are defined as follows:

- HcRhDescriptorA
- HcRhDescriptorB
- HcRhStatus
- HcRhPortStatus[1:NDP]

Each register is read and written as a Dword. These registers are only written during initialization to correspond with the system implementation. The HcRhDescriptorA and HcRhDescriptorB registers should be implemented such that they are writeable regardless of the HCs USB states. HcRhStatus and HcRhPortStatus must be writeable during the USBOPERATIONAL state.

13.3.1 HcRhDescriptorA Register

The HcRhDescriptorA register is the first register of two describing the characteristics of the Root Hub. Reset values are implementation-specific (IS). The descriptor length (11), descriptor type and hub controller current (0) fields of the hub Class Descriptor are emulated by the HCD. All other fields are located in the registers HcRhDescriptorA and HcRhDescriptorB.

Remark: IS denotes an implementation-specific reset value for that field.

Table 36: HcRhDescriptorA Register: bit description

Bit	31	30	29	28	27	26	25	24
Symbol	POTPGT[7:0]							
Reset	IS							
Access	R/W							
Bit	23	22	21	20	19	18	17	16
Symbol	reserved							
Reset	00H							
Access	R/W							
Bit	15	14	13	12	11	10	9	8
Symbol	reserved			NOCP	OCPM	DT	NPS	PSM
Reset	0	0	0	IS	IS	0	IS	IS
Access	R/W			R/W	R/W	R	R/W	R/W
Bit	7	6	5	4	3	2	1	0
Symbol	NDP[7:0]							
Reset	IS							
Access	R							

Table 37: HcRhDescriptorA Register: bit description

Bit	Symbol	Description
31 to 24	POTPGT [7:0]	PowerOnToPowerGoodTime: This byte specifies the duration HCD has to wait before accessing a powered-on port of the Root Hub. It is implementation-specific (IS). The unit of time is 2 ms. The duration is calculated as POTPGT × 2 ms.
23 to 13	-	reserved
12	NOCP	NoOverCurrentProtection: This bit describes how the overcurrent status for the Root Hub ports are reported. When this bit is cleared, the OverCurrentProtectionMode field specifies global or per-port reporting. 0 — overcurrent status is reported collectively for all downstream ports 1 — no overcurrent protection supported
11	OCPM	OverCurrentProtectionMode: This bit describes how the overcurrent status for the Root Hub ports is reported. At reset, this field should reflect the same mode as PowerSwitchingMode. This field is valid only if the NoOverCurrentProtection field is cleared. 0 — overcurrent status is reported collectively for all downstream ports 1 — overcurrent status is reported on a per-port basis
10	DT	DeviceType: This bit specifies that the Root Hub is not a compound device—it is not permitted. This field should always read/write 0.
9	NPS	NoPowerSwitching: These bits are used to specify whether power switching is supported or ports are always powered. It is implementation-specific. When this bit is cleared, the bit PowerSwitchingMode specifies global or per-port switching. 0 — ports are power switched 1 — ports are always powered on when the HC is powered on
8	PSM	PowerSwitchingMode: This bit is used to specify how the power switching of the Root Hub ports is controlled. It is implementation-specific. This field is valid only if the NoPowerSwitching field is cleared. 0 — all ports are powered at the same time 1 — each port is powered individually. This mode allows port power to be controlled by either the global switch or per-port switching. If the bit PortPowerControlMask is set, the port responds to only port power commands (Set/ClearPortPower). If the port mask is cleared, then the port is controlled only by the global power switch (Set/ClearGlobalPower).
7 to 0	NDP[7:0]	NumberDownstreamPorts: These bits specify the number of downstream ports supported by the Root Hub. It is implementation-specific. The minimum number of ports is 1. The maximum number of ports supported by OpenHCI is 2.

Code (Hex): 12 — read

Code (Hex): 92 — write

13.3.2 HcRhDescriptorB Register

The HcRhDescriptorB register is the second register of two describing the characteristics of the Root Hub. These fields are written during initialization to correspond with the system implementation. Reset values are implementation-specific (IS).

Table 38: HcRhDescriptorB Register: bit allocation

Bit	31	30	29	28	27	26	25	24
Symbol	PPCM[15:8]							
Reset	IS							
Access	R/W							
Bit	23	22	21	20	19	18	17	16
Symbol	PPCM[7:0]							
Reset	IS							
Access	R/W							
Bit	15	14	13	12	11	10	9	8
Symbol	DR[15:8]							
Reset	IS							
Access	R/W							
Bit	7	6	5	4	3	2	1	0
Symbol	DR[7:0]							
Reset	IS							
Access	R/W							

Table 39: HcRhDescriptorB Register: bit description

Bit	Symbol	Description
31 to 16	PPCM [15:0]	<p>PortPowerControlMask: Each bit indicates whether a port is affected by a global power control command when PowerSwitchingMode is set. When set, the port's power state is only affected by per-port power control (Set/ClearPortPower). When cleared, the port is controlled by the global power switch (Set/ClearGlobalPower). If the device is configured to global switching mode (PowerSwitchingMode = 0), this field is not valid.</p> <p>Bit 0 — reserved</p> <p>Bit 1 — Ganged-power mask on Port #1</p> <p>Bit 2 — Ganged-power mask on Port #2</p> <p>...</p> <p>Bit 15 — Ganged-power mask on Port #15</p>
15 to 0	DR [15:0]	<p>DeviceRemovable: Each bit is dedicated to a port of the Root Hub. When cleared, the attached device is removable. When set, the attached device is not removable.</p> <p>Bit 0 — reserved</p> <p>Bit 1 — Device attached to Port #1</p> <p>Bit 2 — Device attached to Port #2</p> <p>...</p> <p>Bit 15 — Device attached to Port #15</p>

Code (Hex): 13 — read

Code (Hex): 93 — write

13.3.3 HcRhStatus Register

The HcRhStatus register is divided into two parts. The lower word of a Dword represents the Hub Status field and the upper word represents the Hub Status Change field. Reserved bits should always be written as logic 0.

Table 40: HcRhStatus Register: bit allocation

Bit	31	30	29	28	27	26	25	24
Symbol	CRWE	reserved						
Reset	N/A	N/A						
Access	W	N/A						
Bit	23	22	21	20	19	18	17	16
Symbol	reserved						CCIC	LPSC
Reset	N/A						0	0
Access	N/A						R/W	R/W
Bit	15	14	13	12	11	10	9	8
Symbol	DRWE	reserved						
Reset	0	0	0	0	0	0	0	0
Access	R/W	-						
Bit	7	6	5	4	3	2	1	0
Symbol	reserved						OCI	LPS
Reset	0	0	0	0	0	0	0	0
Access	N/A						R	R/W

Table 41: HcRhStatus Register: bit description

Bit	Symbol	Description
31	CRWE	On write— ClearRemoteWakeupEnable : Writing a logic 1 clears DeviceRemoveWakeupEnable. Writing a logic 0 has no effect.
30 to 18	-	reserved
17	CCIC	OverCurrentIndicatorChange : This bit is set by hardware when a change has occurred to the OCI field of this register. The HCD clears this bit by writing a logic 1. Writing a logic 0 has no effect.
16	LPSC	On read— LocalPowerStatusChange : The Root Hub does not support the local power status feature. Therefore, this bit is always read as logic 0. On write— SetGlobalPower : In global power mode (PowerSwitchingMode=0), this bit is written to logic 1 to turn on power to all ports (clear PortPowerStatus). In per-port power mode, it sets PortPowerStatus only on ports whose bit PortPowerControlMask is not set. Writing a logic 0 has no effect.
15	DRWE	On read— DeviceRemoteWakeupEnable : This bit enables the bit ConnectStatusChange as a resume event, causing a state transition USBSUSPEND to USBRESUME and setting the ResumeDetected interrupt. 0 — ConnectStatusChange is not a remote wakeup event 1 — ConnectStatusChange is a remote wakeup event On write— SetRemoteWakeupEnable : Writing a logic 1 sets DeviceRemoveWakeupEnable. Writing a logic 0 has no effect.
14 to 2	-	reserved
1	OCI	OverCurrentIndicator : This bit reports overcurrent conditions when global reporting is implemented. When set, an overcurrent condition exists. When clear, all power operations are normal. If per-port overcurrent protection is implemented this bit is always logic 0.
0	LPS	On read— LocalPowerStatus : The Root Hub does not support the local power status feature. Therefore, this bit is always read as logic 0. On write— ClearGlobalPower : In global power mode (PowerSwitchingMode = 0), this bit is written to logic 1 to turn off power to all ports (clear PortPowerStatus). In per-port power mode, it clears PortPowerStatus only on ports whose PortPowerControlMask bit is not set. Writing a logic 0 has no effect.

Code (Hex): 14 — read

Code (Hex): 94 — write

13.3.4 HcRhPortStatus[1:2]

The HcRhPortStatus[1:2] register is used to control and report port events on a per-port basis. NumberDownstreamPorts represents the number of HcRhPortStatus registers that are implemented in hardware. The lower word is used to reflect the port status, whereas the upper word reflects the status change bits. Some status bits are implemented with special write behavior. If a transaction (token through handshake) is in progress when a write to change port status occurs, the resulting port status change must be postponed until the transaction completes. Reserved bits should always be written logic 0.

Table 42: HcRhPortStatus[1:2] Register: bit allocation

Bit	31	30	29	28	27	26	25	24
Symbol	reserved							
Reset	00H							
Access	R/W							
Bit	23	22	21	20	19	18	17	16
Symbol	reserved			PRSC	OCIC	PSSC	PESC	CSC
Reset	0	0	0	0	0	0	0	0
Access	R/W			R/W	R/W	R/W	R/W	R/W
Bit	15	14	13	12	11	10	9	8
Symbol	reserved						LSDA	PPS
Reset	N/A						X	0
Access	N/A						R/W	R/W
Bit	7	6	5	4	3	2	1	0
Symbol	reserved			PRS	POCI	PSS	PES	CCS
Reset	0	0	0	0	0	0	0	0
Access	R/W			R/W	R/W	R/W	R/W	R/W

Table 43: HcRhPortStatus[1:2] Register: bit description

Bit	Symbol	Description
31 to 21	-	reserved
20	PRSC	<p>PortResetStatusChange: This bit is set at the end of the 10 ms port reset signal. The HCD writes a logic 1 to clear this bit. Writing a logic 0 has no effect.</p> <p>0 — port reset is not complete 1 — port reset is complete</p>
19	OCIC	<p>PortOverCurrentIndicatorChange: This bit is valid only if overcurrent conditions are reported on a per-port basis. This bit is set when Root Hub changes the PortOverCurrentIndicator bit. The HCD writes a logic 1 to clear this bit. Writing a logic 0 has no effect.</p> <p>0 — no change in PortOverCurrentIndicator 1 — PortOverCurrentIndicator has changed</p>
18	PSSC	<p>PortSuspendStatusChange: This bit is set when the full resume sequence has been completed. This sequence includes the 20 s resume pulse, LS EOP, and 3 ms re-synchronization delay. The HCD writes a logic 1 to clear this bit. Writing a logic 0 has no effect. This bit is also cleared when ResetStatusChange is set.</p> <p>0 — resume is not completed 1 — resume is completed</p>
17	PESC	<p>PortEnableStatusChange: This bit is set when hardware events cause the PortEnableStatus bit to be cleared. Changes from HCD writes do not set this bit. The HCD writes a logic 1 to clear this bit. Writing a logic 0 has no effect.</p> <p>0 — no change in PortEnableStatus 1 — change in PortEnableStatus</p>
16	CSC	<p>ConnectStatusChange: This bit is set whenever a connect or disconnect event occurs. The HCD writes a logic 1 to clear this bit. Writing a logic 0 has no effect. If CurrentConnectStatus is cleared when a SetPortReset, SetPortEnable, or SetPortSuspend write occurs, this bit is set to force the driver to re-evaluate the connection status since these writes should not occur if the port is disconnected.</p> <p>0 — no change in CurrentConnectStatus 1 — change in CurrentConnectStatus</p> <p>Remark: If the DeviceRemovable[NDP] bit is set, this bit is set only after a Root Hub reset to inform the system that the device is attached.</p>
15 to 10	-	reserved
9	LSDA	<p>(read) LowSpeedDeviceAttached: This bit indicates the speed of the device attached to this port. When set, a low-speed device is attached to this port. When clear, a full-speed device is attached to this port. This field is valid only when the CurrentConnectStatus is set.</p> <p>0 — full-speed device attached 1 — low-speed device attached</p> <p>(write) ClearPortPower: The HCD clears the PortPowerStatus bit by writing a logic 1 to this bit. Writing a logic 0 has no effect.</p>

Table 43: HcRhPortStatus[1:2] Register: bit description...continued

Bit	Symbol	Description
8	PPS	<p>(read) PortPowerStatus: This bit reflects the port power status, regardless of the type of power switching implemented. This bit is cleared if an overcurrent condition is detected.</p> <p>The HCD sets this bit by writing SetPortPower or SetGlobalPower. The HCD clears this bit by writing ClearPortPower or ClearGlobalPower. Which power control switches are enabled is determined by PowerSwitchingMode.</p> <p>In the global switching mode (PowerSwitchingMode = 0), only Set/ClearGlobalPower controls this bit. In per-port power switching (PowerSwitchingMode = 1), if the PortPowerControlMask[NDP] bit for the port is set, only Set/ClearPortPower commands are enabled. If the mask is not set, only Set/ClearGlobalPower commands are enabled.</p> <p>When port power is disabled, CurrentConnectStatus, PortEnableStatus, PortSuspendStatus, and PortResetStatus should be reset.</p> <p>0 — port power is off 1 — port power is on</p> <p>(write) SetPortPower: The HCD writes a logic 1 to set the PortPowerStatus bit. Writing a logic 0 has no effect.</p> <p>Remark: This bit always reads logic 1 if power switching is not supported.</p>
7 to 5	-	reserved
4	PRS	<p>(read) PortResetStatus: When this bit is set by a write to SetPortReset, port reset signaling is asserted. When reset is completed, this bit is cleared when PortResetStatusChange is set. This bit cannot be set if CurrentConnectStatus is cleared.</p> <p>0 — port reset signal is not active 1 — port reset signal is active</p> <p>(write) SetPortReset: The HCD sets the port reset signaling by writing a 1 to this bit. Writing a 0 has no effect. If CurrentConnectStatus is cleared, this write does not set PortResetStatus but instead sets ConnectStatusChange. This informs the driver that it attempted to reset a disconnected port.</p>
3	POCI	<p>(read) PortOverCurrentIndicator: This bit is valid only when the Root Hub is configured in such a way that overcurrent conditions are reported on a per-port basis. If per-port overcurrent reporting is not supported, this bit is set to logic 0. If cleared, all power operations are normal for this port. If set, an overcurrent condition exists on this port. This bit always reflects the overcurrent input signal</p> <p>0 — no overcurrent condition 1 — overcurrent condition detected</p> <p>(write) ClearSuspendStatus: The HCD writes a logic 1 to initiate a resume. Writing a logic 0 has no effect. A resume is initiated only if PortSuspendStatus is set.</p>

Table 43: HcRhPortStatus[1:2] Register: bit description...continued

Bit	Symbol	Description
2	PSS	<p>(read) PortSuspendStatus: This bit indicates whether the port is suspended or in the resume sequence. It is set by a SetSuspendState write and cleared when PortSuspendStatusChange is set at the end of the resume interval. This bit cannot be set if CurrentConnectStatus is cleared. This bit is also cleared when PortResetStatusChange is set at the end of the port reset or when the HC is placed in the USBRESUME state. If an upstream resume is in progress, it should propagate to the HC.</p> <p>0 — port is not suspended 1 — port is suspended</p> <p>(write) SetPortSuspend: The HCD sets the PortSuspendStatus bit by writing a logic 1 to this bit. Writing a logic 0 has no effect. If CurrentConnectStatus is cleared, this write does not set PortSuspendStatus; instead it sets ConnectStatusChange. This informs the driver that it attempted to suspend a disconnected port.</p>
1	PES	<p>(read) PortEnableStatus: This bit indicates whether the port is enabled or disabled. The Root Hub may clear this bit when an overcurrent condition, disconnect event, switched-off power, or operational bus error such as babble is detected. This change also causes PortEnabledStatusChange to be set. The HCD sets this bit by writing SetPortEnable and clears it by writing ClearPortEnable. This bit cannot be set when CurrentConnectStatus is cleared. This bit is also set, if it is not already, at the completion of a port reset when ResetStatusChange is set or port suspend when SuspendStatusChange is set.</p> <p>0 — port is disabled 1 — port is enabled</p> <p>(write) SetPortEnable: The HCD sets PortEnableStatus by writing a logic 1. Writing a logic 0 has no effect. If CurrentConnectStatus is cleared, this write does not set PortEnableStatus, but instead sets ConnectStatusChange. This informs the driver that it attempted to enable a disconnected port.</p>
0	CCS	<p>(read) CurrentConnectStatus: This bit reflects the current state of the downstream port.</p> <p>0 — no device connected 1 — device connected</p> <p>(write) ClearPortEnable: The HCD writes a logic 1 to this bit to clear the PortEnableStatus bit. Writing a logic 0 has no effect. CurrentConnectStatus is not affected by any write.</p> <p>Remark: This bit always reads logic 1 when the attached device is nonremovable (DeviceRemoveable[NDP]).</p>

Code (Hex): [1] = 15, [2] = 16 — read

Code (Hex): [1] = 95, [2] = 96 — write

13.4 HC DMA and interrupt control registers

13.4.1 HcHardwareConfiguration Register

Table 44: HcHardwareConfiguration Register: bit allocation

Bit	15	14	13	12	11	10	9	8
Symbol	reserved			2_DownstreamPort15KresistorSel	SuspendClkNotStop	AnalogOCEnable	reserved	DACKMode
Reset	0	0	0	0	0	0	0	0
Access	R/W			R/W	R/W	R/W	R/W	R/W
Bit	7	6	5	4	3	2	1	0
Symbol	EOTInputPolarity	DACKInputPolarity	DREQOutputPolarity	DataBusWidth		InterruptOutputPolarity	InterruptPinTrigger	InterruptPinEnable
Reset	0	0	0	0	1	0	0	0
Access	R/W	R/W	R/W	R/W		R/W	R/W	R/W

Table 45: HcHardwareConfiguration Register: bit description

Bit	Symbol	Description
15 to 13	-	reserved
12	2_DownstreamPort15KresistorSel	0 — use external 15 kΩ resistors for downstream ports 1 — use built-in resistors for downstream ports
11	SuspendClkNotStop	0 — Clk can be stopped 1 — clock can not be stopped
10	AnalogOCEnable	0 — use external OC detection. Digital input 1 — use on-chip OC detection. Analog input
9	-	reserved
8	DACKMode	0 — normal operation. DACK1 is used with read and write signals. Power-up value. 1 — reserved
7	EOTInputPolarity	0 — active LOW. Power-up value 1 — active HIGH
6	DACKInputPolarity	0 — active LOW. Power-up value 1 — active HIGH
5	DREQOutputPolarity	0 — active LOW 1 — active HIGH. Power-up value
4 to 3	DataBusWidth[1:0]	01 — 16 bits Others — reserved
2	InterruptOutputPolarity	0 — active LOW. Power-up value 1 — active HIGH
1	InterruptPinTrigger	0 — interrupt is level-triggered. Power-up value 1 — Interrupt is edge-triggered.
0	InterruptPinEnable	0 — power-up value 1 — pin Global Interrupt INT1 is enabled

Code (Hex): 20 — read

Code (Hex): A0 — write

Remark:

1. Bit 0, InterruptPinEnable, is used as pin INT1's master interrupt enable. This bit should be used together with the register HcμPInterruptEnable to enable pin INT1.
2. Bits 4:3 are fixed at the value 01B for ISP1161.

13.4.2 HcDMAConfiguration Register

Table 46: HcDMAConfiguration Register: bit allocation

Bit	15	14	13	12	11	10	9	8
Symbol	reserved							
Reset	00H							
Access	R/W							
Bit	7	6	5	4	3	2	1	0
Symbol	reserved	BurstLen[1:0]		DMA Enable	reserved	DMACounterSelect	ITL_ATL_DataSelect	DMAReadWriteSelect
Reset	0	0	0	0	0	0	0	0
Access	R/W	R/W		R/W	R/W	R/W	R/W	R/W

Table 47: HcDMAConfiguration Register: bit description

Bit	Symbol	Description
15 to 8	-	reserved
7	-	reserved
6 to 5	BurstLen[1:0]	00B — single-cycle burst DMA 01B — 4-cycle burst DMA 10B — 8-cycle burst DMA 11B — reserved
4	DMAEnable	0 — DMA is terminated 1 — DMA is enabled This bit will be reset to zero when DMA transfer is completed
3	-	reserved
2	DMACounterSelect	0 — DMA counter not used. External EOT must be used 1 — Enables the DMA counter for DMA transfer. HcTransferCounter register must be filled with non-zero values for DREQ1 to be raised after bit DMA Enable is set
1	ITL_ATL_DataSelect	0 — ITL buffer RAM selected for ITL data 1 — ATL buffer RAM selected for ATL data
0	DMAReadWriteSelect	0 — read from ISP1161 HC's FIFO buffer RAM 1 — write to ISP1161 HC's FIFO buffer RAM

Code (Hex): 21 — read

Code (Hex): A1 — write

13.4.3 HcTransferCounter Register

This register holds the number of bytes of a PIO or DMA transfer. For a PIO transfer, the number of bytes being read or written to the (Isochronous Transfer List) ITL or (Acknowledged Transfer List) ATL buffer RAM must be written into this register. For a DMA transfer, the number of bytes must be written into this register as well. However, for this counter to be read into the DMA counter, the HCD must set bit 2 of the HcDMAConfiguration register. The counter value for ATL must not be greater than 1000H, and for ITL it must not be greater than 800H. When the byte count of the data transfer reaches this value, the HC will generate an internal EOT signal to set bit 2 AllEOInterrupt, of the HcPIInterrupt register, and also update the HcBufferStatus register.

Table 48: HcTransferCounter Register: bit allocation

Bit	15	14	13	12	11	10	9	8
Symbol	Counter value							
Reset	0	0	0	0	0	0	0	0
Access	R/W							
Bit	7	6	5	4	3	2	1	0
Symbol	Counter value							
Reset	0	0	0	0	0	0	0	0
Access	R/W							

Table 49: HcTransferCounter Register: bit description

Bit	Symbol	Description
15 to 0	Counter value	The number of data bytes to be read to or written from RAM

Code (Hex): 22 — read

Code (Hex): A2 — write

13.4.4 HcPIInterrupt Register

All the bits in this register will be active on power-on reset. However, none of the active bits will cause an interrupt on the interrupt pin (INT1) unless they are set by the respective bits in the HcPIInterruptEnable register, and together with bit 0 of the HcHardwareConfiguration register.

After this register (24H Read) is read, the bits that are active will not be reset, until logic 1 is written to the bits in this register (A4H - Write) to clear it.

The bits in this register are cleared only when you write to this register indicating the bits to be cleared. To clear all the enabled bits in this register, the HCD must write FFH to this register.

Table 50: HcμPInterrupt Register: bit allocation

Bit	15	14	13	12	11	10	9	8
Symbol	reserved							
Reset	00H							
Access	R/W							
Bit	7	6	5	4	3	2	1	0
Symbol	reserved	ClkReady	HC Suspended	OPR_Reg	reserved	AIIEOT Interrupt	ATLInt	SOFITLInt
Reset	0	0	0	0	0	0	0	0
Access	R/W							

Table 51: HcμPInterrupt Register: bit description

Bit	Symbol	Description
15 to 8	-	reserved
7	-	reserved
6	ClkReady	0 — no event 1 — clock is ready. (After a wakeup is sent, there is a wait for clock ready. Maximum is 1 ms, and typical is 160 μs)
5	HCSuspended	0 — no event 1 — the HC has been suspended and no USB activity is sent from the microprocessor for each ms. When the microprocessor wants to suspend the HC, the microprocessor must write to the HcControl register. And when all downstream devices are suspended, then the HC stops sending SOF; the HC is suspended by having the HcControl register written into.
4	OPR_Reg	read HcControl and HcInterrupt registers to detect type of interrupt on the HC (if the HC requires the Operational register to be updated)
3	-	reserved
2	AIIEOTInterrupt	0 — no event 1 — implies that data transfer has been finished via PIO transfer or DMA transfer. Occurrence of internal or external EOT will set this bit.
1	ATLInt	0 — no event 1 — implies that the microprocessor must read ATL data from the HC. This requires that the HcBufferStatus register must first be read. The time for this interrupt depends on the number of clocks bit set for USB activities in each ms.
0	SOFITLInt	0 — no event 1 — implies that SOF indicates the 1 ms mark. The ITL buffer that the HC has handled must be read. To know the ITL buffer status, the HcBufferStatus Register must first be read. This is for microprocessor to get ISO data to or from the HC. For more information, see Section 9.5 on page 33 6th paragraph.

Code (Hex): 24 — read

Code (Hex): A4 — write

13.4.5 HcuPInterruptEnable Register

The bits 6:0 in this register are the same as those in the HcuPInterrupt register. They are used together with bit 0 of the HcHardwareConfiguration register to enable or disable the bits in the HcuPInterrupt register.

On power-on, all bits in this register are masked with 0. This means no interrupt request output on the interrupt pin INT1 can be generated.

When the bit is set to 1, the interrupt for the bit is not masked but enabled.

Table 52: HcuPInterruptEnable Register: bit allocation

Bit	15	14	13	12	11	10	9	8
Symbol	reserved							
Reset	00H							
Access	R/W							
Bit	7	6	5	4	3	2	1	0
Symbol	reserved	ClkReady	HC Suspended Enable	OPR Interrupt Enable	reserved	EOT Interrupt Enable	ATL Interrupt Enable	SOF Interrupt Enable
Reset	0	0	0	0	0	0	0	0
Access	R/W							

Table 53: HcuPInterruptEnable Register: bit description

Bit	Symbol	Description
15 to 8	-	reserved
7	-	reserved
6	ClkReady	0 — power-up value 1 — enables Clkready interrupt
5	HC Suspended Enable	0 — power-up value 1 — enables HC suspended interrupt. When the microprocessor wants to suspend the HC, the microprocessor must write to the HcControl register. And when all downstream devices are suspended, then the HC stops sending SOF; the HC is suspended by having the HcControl register written into.
4	OPR Interrupt Enable	0 — power-up value 1 — enables the 32-bit Operational register's interrupt (if the HC requires the Operational register to be updated)
3	-	reserved
2	EOT Interrupt Enable	0 — power-up value 1 — enables the EOT interrupt which indicates an end of a Read/Write transfer
1	ATL Interrupt Enable	0 — power-up value 1 — enables ATL interrupt. The time for this interrupt depends on the number of clock bits set for USB activities in each ms.
0	SOF Interrupt Enable	0 — power-up value 1 — enables the interrupt bit due to SOF (for the microprocessor DMA to get ISO data from the HC by first accessing the HcDMAConfiguration register)

Code (Hex): 25 — read

Code (Hex): A5 — write

13.5 HC miscellaneous registers

13.5.1 HcChipID Register

Read this register to get the ID of the ISP1161 silicon chip. The high byte stands for the product name (here 61H stands for ISP1161). The low byte indicates the revision number of the product including engineering samples (here 10H means revision 1, that is ES1 of ISP1161).

Table 54: HcChipID Register: bit allocation

Bit	15	14	13	12	11	10	9	8
Symbol	ChipID[15:8]							
Reset	0	1	1	0	0	0	0	1
Access	R							
Bit	7	6	5	4	3	2	1	0
Symbol	ChipID[7:0]							
Reset	0	0	0	0	0	0	0	0
Access	R							

Table 55: HcChipID Register: bit description

Bit	Symbol	Description
15 to 0	ChipID [15:0]	ISP1161's chip ID

Code (Hex): 27 — read

13.5.2 HcScratch Register

This register is for the HCD to save and restore values when required.

Table 56: HcScratch Register: bit allocation

Bit	15	14	13	12	11	10	9	8
Symbol	Scratch[15:8]							
Reset	0	0	0	0	0	0	0	0
Access	R/W							
Bit	7	6	5	4	3	2	1	0
Symbol	Scratch[7:0]							
Reset	0	0	0	0	0	0	0	0
Access	R/W							

Table 57: HcScratch Register: bit description

Bit	Symbol	Description
15 to 0	Scratch [15:0]	Scratch register value

Code (Hex): 28 — read

Code (Hex): A8 — write

13.5.3 HcSoftwareReset Register

This is a soft reset command. The microprocessor writes A9H to ISP1161's command port, resetting all the HC's internal registers except for the internal FIFO buffer RAM.

Table 58: HcSoftwareReset Register: bit allocation

Bit	15	14	13	12	11	10	9	8
Symbol	Reset[15:8]							
Reset	X	X	X	X	X	X	X	X
Access	W							
Bit	7	6	5	4	3	2	1	0
Symbol	Reset[7:0]							
Reset	1	1	1	1	0	1	1	0
Access	W							

Table 59: HcSoftwareReset Register: bit description

Bit	Symbol	Description
15 to 0	Reset[15:0]	Soft reset command

Code (Hex): A9 — write

13.6 HC buffer RAM control registers

13.6.1 HcITLBufferLength Register

Write to this register to assign the ITL buffer size in bytes for both ITL0 and ITL1 simultaneously. Thus, the ITL0 and ITL1 always have the same size.

Must follow the formula:

$$\text{ATL buffer length} + 2 \times (\text{ITL buffer size}) \leq 1000\text{H (that is, 4 kbytes)}$$

where: ITL buffer size = ITL0 buffer length = ITL1 buffer length

Table 60: HcITLBufferLength Register: bit allocation

Bit	15	14	13	12	11	10	9	8
Symbol	ITLBufferLength[15:8]							
Reset	0	0	0	0	0	0	0	0
Access	R/W							
Bit	7	6	5	4	3	2	1	0
Symbol	ITLBufferLength[7:0]							
Reset	0	0	0	0	0	0	0	0
Access	R/W							

Table 61: HciITLBufferLength Register: bit description

Bit	Symbol	Description
15 to 0	ITLBufferLength [15:0]	Assign ITL buffer length

Code (Hex): 2A — read

Code (Hex): AA — write

13.6.2 HcATLBufferLength Register

Write to this register to assign ATL buffer size.

Table 62: HcATLBufferLength Register: bit allocation

Bit	15	14	13	12	11	10	9	8
Symbol	ATLBufferLength[15:8]							
Reset	0	0	0	0	0	0	0	0
Access	R/W							
Bit	7	6	5	4	3	2	1	0
Symbol	ATLBufferLength[7:0]							
Reset	0	0	0	0	0	0	0	0
Access	R/W							

Table 63: HcATLBufferLength Register: bit description

Bit	Symbol	Description
15 to 0	ATLBufferLength [15:0]	Assign ATL buffer length

Code (Hex): 2B — read

Code (Hex): AB — write

Remark: The maximum total RAM size is 1000H (4096 in decimal) bytes. That means ITL0 (length) + ITL1 (length) + ATL (length) ≤ 1000H bytes. For example: If ATL buffer length has been set to be 800H, then the maximum ITL buffer length can only be set as 400H.

13.6.3 HcBufferStatus Register

Table 64: HcBufferStatus Register: bit allocation

Bit	15	14	13	12	11	10	9	8
Symbol	reserved							
Reset	00H							
Access	R							
Bit	7	6	5	4	3	2	1	0
Symbol	reserved		ATLBuffer Done	ITL1Buffer Done	ITL0Buffer Done	ATLBuffer Full	ITL1Buffer Full	ITL0Buffer Full
Reset	0	0	0	0	0	0	0	0
Access	R		R	R	R	R	R	R

Table 65: HcBufferStatus Register: bit description

Bit	Symbol	Description
15 to 8	-	reserved
7 to 6	-	reserved
5	ATLBuffer Done	0 — ATL Buffer not read by HC yet 1 — ATL Buffer read by HC
4	ITL1Buffer Done	0 — ITL1 Buffer not read by HC yet 1 — ITL1 Buffer read by HC
3	ITL0Buffer Done	0 — ITL0 Buffer not read by HC yet 1 — ITL0 Buffer read by HC
2	ATLBuffer Full	0 — ATL Buffer is empty 1 — ATL Buffer is full
1	ITL1Buffer Full	0 — ITL1 Buffer is empty 1 — ITL1 Buffer is full
0	ITL0Buffer Full	0 — ITL0 Buffer is empty 1 — ITL0 Buffer is full

Code (Hex): 2C — read

13.6.4 HcReadBackITL0Length Register

This register's value stands for the current number of data bytes inside an ITL0 buffer to be read back by the microprocessor. The HCD must set the HcTransferCounter equivalent to this value before reading back the ITL0 buffer RAM.

Table 66: HcReadBackITL0Length Register: bit allocation

Bit	15	14	13	12	11	10	9	8
Symbol	RdITL0BufferLength[15:8]							
Reset	0	0	0	0	0	0	0	0
Access	R							
Bit	7	6	5	4	3	2	1	0
Symbol	RdITL0BufferLength[7:0]							
Reset	0	0	0	0	0	0	0	0
Access	R							

Table 67: HcReadBackITL0Length Register: bit description

Bit	Symbol	Description
15 to 0	RdITL0BufferLength [15:0]	The number of bytes for ITL0 data to be read back by the microprocessor

Code (Hex): 2D — read

13.6.5 HcReadBackITL1Length Register

This register's value stands for the current number of data bytes inside the ITL1 buffer to be read back by the microprocessor. The HCD must set the HcTransferCounter equivalent to this value before reading back the ITL1 buffer RAM.

Table 68: HcReadBackITL1Length Register: bit allocation

Bit	15	14	13	12	11	10	9	8
Symbol	RdITL1BufferLength[15:8]							
Reset	0	0	0	0	0	0	0	0
Access	R							
Bit	7	6	5	4	3	2	1	0
Symbol	RdITL1BufferLength[7:0]							
Reset	0	0	0	0	0	0	0	0
Access	R							

Table 69: HcReadBackITL1Length Register: bit description

Bit	Symbol	Description
15 to 0	RdITL1BufferLength [15:0]	The number of bytes for ITL1 data to be read back by the microprocessor

Code (Hex): 2E — read

13.6.6 HcITLBufferPort Register

This is the ITL buffer RAM read/write port. The bits 15:8 contain the data byte that comes from the ITL buffer RAM's even address. The bits 7:0 contain the data byte that comes from the ITL buffer RAM's odd address.

Table 70: HcITLBufferPort Register: bit allocation

Bit	15	14	13	12	11	10	9	8
Symbol	DataWord[15:8]							
Reset	0	0	0	0	0	0	0	0
Access	R/W							
Bit	7	6	5	4	3	2	1	0
Symbol	DataWord[7:0]							
Reset	0	0	0	0	0	0	0	0
Access	R/W							

Table 71: HcITLBufferPort Register: bit description

Bit	Symbol	Description
15 to 0	DataWord[15:0]	Read/Write ITL buffer RAM's two data bytes.

Code (Hex): 40 — read

Code (Hex): C0 — write

The HCD must set the byte count into the HcTransferCounter register and check the HcBufferStatus register before reading from or writing to the buffer. The HCD must write the command (40H for read, C0H for write) once only, and then read or write all the data bytes in word. After every read/write, the pointer of ITL buffer RAM will be automatically increased by two to point to the next data word until it reaches the value of HcTransferCounter register; otherwise, an internal EOT signal is not generated to set the bit 2 AllEOTInterrupt, of the HcUpInterrupt register and update the HcBufferStatus register.

The HCD must take care of the difference that the internal buffer RAM is organized in bytes. The HCD must write the byte count into the HcTransferCounter register, but the HCD reads or writes the buffer RAM by 16 bits (by 1 word).

13.6.7 HcATLBufferPort Register

This is the ATL buffer RAM read/write port. The bits 15:8 contain the data byte that comes from the Acknowledged Transfer List (ATL) buffer RAM's even address. The bits 7:0 contain the data byte that comes from the ATL buffer RAM's odd address.

Table 72: HcATLBufferPort Register: bit allocation

Bit	15	14	13	12	11	10	9	8
Symbol	DataWord[15:8]							
Reset	0	0	0	0	0	0	0	0
Access	R/W							
Bit	7	6	5	4	3	2	1	0
Symbol	DataWord[7:0]							
Reset	0	0	0	0	0	0	0	0
Access	R/W							

Table 73: HcATLBufferPort Register: bit description

Bit	Symbol	Description
15 to 0	DataWord[15:0]	Read/Write ATL buffer RAM's two data bytes.

Code (Hex): 41 — read

Code (Hex): C1 — write

The HCD must set the byte count into the HcTransferCounter register and check the HcBufferStatus register before reading from or writing to the buffer. The HCD must write the command (41H for read, C1H for write) once only, and then read or write all the data bytes in word. After every read/write, the pointer of ATL buffer RAM will be automatically increased by two to point to the next data word until it reaches the value of HcTransferCounter register; otherwise, an internal EOT signal is not generated to set the bit 2 AllEOTInterrupt, of the HcμPInterrupt register and update the HcBufferStatus register.

The HCD must take care of the difference: the internal buffer RAM is organized in bytes, so the HCD must write the byte count into the HcTransferCounter register, but the HCD reads or writes the buffer RAM by 16 bits (by 1 word).

14. DC commands and registers

The functions and registers of ISP1161 are accessed via commands, which consist of a command code followed by optional data bytes (read or write action). An overview of the available commands and registers is given in [Table 74](#).

A complete access consists of two phases:

1. **Command phase:** when address bit A0 = 1, the DC interprets the data on the lower byte of the bus (bits D7 to D0) as a command code. Commands without a data phase are executed immediately.
2. **Data phase (optional):** when address bit A0 = 0, the DC transfers the data on the bus to or from a register or endpoint FIFO. Multi-byte registers are accessed least significant byte/word first.

As the ISP1161 DC's data bus is 16 bits wide:

- The upper byte (bits D15 to D8) in command phase or the undefined byte in data phase is ignored.
- The access of registers is word-aligned: byte access is not allowed.
- If the packet length is odd, the upper byte of the last word in an IN endpoint buffer is **not** transmitted to the host. When reading from an OUT endpoint buffer, the upper byte of the last word must be ignored by the firmware. The packet length is stored in the first 2 bytes of the endpoint buffer.

Table 74: Command and register summary

Name	Destination	Code (Hex)	Transaction ^[1]
Initialization commands			
Write Control OUT Configuration	Endpoint Configuration Register endpoint 0 OUT	20	write 1 word
Write Control IN Configuration	Endpoint Configuration Register endpoint 0 IN	21	write 1 word
Write Endpoint n Configuration (n = 1 to 14)	Endpoint Configuration Register endpoint 1 to 14	22 to 2F	write 1 word
Read Control OUT Configuration	Endpoint Configuration Register endpoint 0 OUT	30	read 1 word
Read Control IN Configuration	Endpoint Configuration Register endpoint 0 IN	31	read 1 word
Read Endpoint n Configuration (n = 1 to 14)	Endpoint Configuration Register endpoint 1 to 14	32 to 3F	read 1 word
Write/Read Device Address	Address Register	B6/B7	write/read 1 word
Write/Read Mode Register	Mode Register	B8/B9	write/read 1 word
Write/Read Hardware Configuration	Hardware Configuration Register	BA/BB	write/read 1 word
Write/Read Interrupt Enable Register	Interrupt Enable Register	C2/C3	write/read 2 words
Write/Read DMA Configuration	DMA Configuration Register	F0/F1	write/read 1 word
Write/Read DMA Counter	DMA Counter Register	F2/F3	write/read 1 word
Reset Device	resets all registers	F6	-
Data flow commands			
Write Control OUT Buffer	illegal: endpoint is read-only	(00)	-
Write Control IN Buffer	FIFO endpoint 0 IN	01	N ≤ 64 bytes
Write Endpoint n Buffer (n = 1 to 14)	FIFO endpoint 1 to 14 (IN endpoints only)	02 to 0F	isochronous: N ≤ 1023 bytes interrupt/bulk: N ≤ 64 bytes
Read Control OUT Buffer	FIFO endpoint 0 OUT	10	N ≤ 64 bytes
Read Control IN Buffer	illegal: endpoint is write-only	(11)	-

Table 74: Command and register summary...continued

Name	Destination	Code (Hex)	Transaction ^[1]
Read Endpoint n Buffer (n = 1 to 14)	FIFO endpoint 1 to 14 (OUT endpoints only)	12 to 1F	isochronous: N ≤ 1023 bytes ^[6] interrupt/bulk: N ≤ 64 bytes
Stall Control OUT Endpoint	Endpoint 0 OUT	40	-
Stall Control IN Endpoint	Endpoint 0 IN	41	-
Stall Endpoint n (n = 1 to 14)	Endpoint 1 to 14	42 to 4F	-
Read Control OUT Status	Endpoint Status Register endpoint 0 OUT	50	read 1 word
Read Control IN Status	Endpoint Status Register endpoint 0 IN	51	read 1 word
Read Endpoint n Status (n = 1 to 14)	Endpoint Status Register n endpoint 1 to 14	52 to 5F	read 1 word
Validate Control OUT Buffer	illegal: IN endpoints only ^[2]	(60)	-
Validate Control IN Buffer	FIFO endpoint 0 IN ^[2]	61	none
Validate Endpoint n Buffer (n = 1 to 14)	FIFO endpoint 1 to 14 (IN endpoints only) ^[2]	62 to 6F	none
Clear Control OUT Buffer	FIFO endpoint 0 OUT	70	none
Clear Control IN Buffer	illegal ^[3]	(71)	-
Clear Endpoint n Buffer (n = 1 to 14)	FIFO endpoint 1 to 14 (OUT endpoints only) ^[3]	72 to 7F	none
Uninstall Control OUT Endpoint	Endpoint 0 OUT	80	-
Uninstall Control IN Endpoint	Endpoint 0 IN	81	-
Uninstall Endpoint n (n = 1 to 14)	Endpoint 1 to 14	82 to 8F	-
Check Control OUT Status ^[4]	Endpoint Status Image Register endpoint 0 OUT	D0	read 1 word
Check Control IN Status ^[4]	Endpoint Status Image Register endpoint 0 IN	D1	read 1 word
Check Endpoint n Status (n = 1 to 14) ^[4]	Endpoint Status Image Register n endpoint 1 to 14	D2 to DF	read 1 word
Acknowledge Setup	Endpoint 0 IN and OUT	F4	none
General commands			
Read Control OUT Error Code	Error Code Register endpoint 0 OUT	A0	read 1 word ^[5]
Read Control IN Error Code	Error Code Register endpoint 0 IN	A1	read 1 word ^[5]
Read Endpoint n Error Code (n = 1 to 14)	Error Code Register endpoint 1 to 14	A2 to AF	read 1 word ^[5]
Unlock Device	all registers with write access	B0	write 1 word
Write/Read Scratch Register	Scratch Register	B2/B3	write/read 1 word
Read frame Number	Frame Number Register	B4	read 1 word

Table 74: Command and register summary...continued

Name	Destination	Code (Hex)	Transaction ^[1]
Read Chip ID	Chip ID Register	B5	read 1 word
Read Interrupt Register	Interrupt Register	C0	read 2 words

- [1] With N representing the number of bytes, the number of words for 16-bit bus width is: (N + 1) DIV 2.
- [2] Validating an OUT endpoint buffer causes unpredictable behavior of ISP1161's DC.
- [3] Clearing an IN endpoint buffer causes unpredictable behavior of ISP1161's DC.
- [4] Reads a copy of the Status Register: executing this command does not clear any status bits or interrupt bits.
- [5] When accessing an 8-bit register in 16-bit mode, the upper byte is invalid.
- [6] During isochronous transfer in 16-bit mode, because $N \leq 1023$, the firmware must take care of the upper byte.

14.1 Initialization commands

Initialization commands are used during the enumeration process of the USB network. These commands are used to configure and enable the embedded endpoints. They also serve to set the USB assigned address of ISP1161's DC and to perform a device reset.

14.1.1 Write/Read Endpoint Configuration

This command is used to access the Endpoint Configuration Register (ECR) of the target endpoint. It defines the endpoint type (isochronous or bulk/interrupt), direction (OUT/IN), FIFO size and buffering scheme. It also enables the endpoint FIFO. The register bit allocation is shown in Table 75. A bus reset will disable all endpoints.

The allocation of FIFO memory only takes place after **all** 16 endpoints have been configured in sequence (from endpoint 0 OUT to endpoint 14). Although the control endpoints have fixed configurations, they must be included in the initialization sequence and be configured with their default values (see Table 7). Automatic FIFO allocation starts when endpoint 14 has been configured.

Remark: If any change is made to an endpoint configuration which affects the allocated memory (size, enable/disable), the FIFO memory contents of **all** endpoints becomes invalid. Therefore, all valid data must be removed from enabled endpoints before changing the configuration.

Code (Hex): 20 to 2F — write (control OUT, control IN, endpoint 1 to 14)

Code (Hex): 30 to 3F — read (control OUT, control IN, endpoint 1 to 14)

Transaction — write/read 1 word

Table 75: Endpoint Configuration Register: bit allocation

Bit	7	6	5	4	3	2	1	0
Symbol	FIFOEN	EPDIR	DBLBUF	FFOISO	FFOSZ[3:0]			
Reset	0	0	0	0	0	0	0	0
Access	R/W	R/W	R/W	R/W	R/W	R/W	R/W	R/W

Table 76: Endpoint Configuration Register: bit description

Bit	Symbol	Description
7	FIFOEN	A logic 1 indicates an enabled FIFO with allocated memory. A logic 0 indicates a disabled FIFO (no bytes allocated).
6	EPDIR	This bit defines the endpoint direction (0 = OUT, 1 = IN); it also determines the DMA transfer direction (0 = read, 1 = write)
5	DBLBUF	A logic 1 indicates that this endpoint has double buffering.
4	FFOISO	A logic 1 indicates an isochronous endpoint. A logic 0 indicates a bulk or interrupt endpoint.
3 to 0	FFOSZ[3:0]	Selects the FIFO size according to Table 8

14.1.2 Write/Read Device Address

This command is used to set the USB assigned address in the Address Register and enable the USB device. The Address Register bit allocation is shown in [Table 77](#).

A USB bus reset sets the device address to 00H (internally) and enables the device. The value of the Address Register (accessible by the microcontroller) is not altered by the bus reset. In response to the standard USB request Set Address the firmware must issue a Write Device Address command, followed by sending an empty packet to the host. The **new** device address is activated when the host acknowledges the empty packet.

Code (Hex): B6/B7 — write/read Address Register

Transaction — write/read 1 word

Table 77: Address Register: bit allocation

Bit	7	6	5	4	3	2	1	0
Symbol	DEVEN	DEVADR[6:0]						
Reset	0	0	0	0	0	0	0	0
Access	R/W	R/W	R/W	R/W	R/W	R/W	R/W	R/W

Table 78: Address Register: bit description

Bit	Symbol	Description
7	DEVEN	A logic 1 enables the device.
6 to 0	DEVADR[6:0]	This field specifies the USB device address.

14.1.3 Write/Read Mode Register

This command is used to access the ISP1161's DC Mode Register, which consists of 1 byte (bit allocation: see [Table 78](#)). In 16-bit bus mode the upper byte is ignored.

The Mode Register controls the DMA bus width, resume and suspend modes, interrupt activity and SoftConnect operation. It can be used to enable debug mode, where all errors and Not Acknowledge (NAK) conditions will generate an interrupt.

Code (Hex): B8/B9 — write/read Mode Register

Transaction — write/read 1 word

Table 79: Mode Register: bit allocation

Bit	7	6	5	4	3	2	1	0
Symbol	DMAWD	reserved	GOSUSP	reserved	INTENA	DBGMOD	reserved	SOFTCT
Reset	0 ^[1]	0	0	0	0 ^[1]	0 ^[1]	0 ^[1]	0 ^[1]
Access	R/W	R/W	R/W	R/W	R/W	R/W	R/W	R/W

[1] Unchanged by a bus reset.

Table 80: Mode Register: bit description

Bit	Symbol	Description
7	DMAWD	A logic 1 selects 16-bit DMA bus width (bus configuration modes 0 and 2). A logic 0 selects 8-bit DMA bus width. Bus reset value: unchanged.
6	-	reserved
5	GOSUSP	Writing a logic 1 followed by a logic 0 will activate 'suspend' mode.
4	-	reserved
3	INTENA	A logic 1 enables all interrupts. Bus reset value: unchanged.
2	DBGMOD	A logic 1 enables debug mode. where all NAKs and errors will generate an interrupt. A logic 0 selects normal operation, where interrupts are generated on every ACK (bulk endpoints) or after every data transfer (isochronous endpoints). Bus reset value: unchanged.
1	-	reserved
0	SOFTCT	A logic 1 enables SoftConnect (see Section 7.5). This bit is ignored if EXTPUL = 1 in the Hardware Configuration Register (see Table 81). Bus reset value: unchanged.

14.1.4 Write/Read Hardware Configuration

This command is used to access the Hardware Configuration Register, which consists of 2 bytes. The first (lower) byte contains the device configuration and control values, the second (upper) byte holds the clock control bits and the clock division factor. The bit allocation is given in Table 81. A bus reset will not change any of the programmed bit values.

The Hardware Configuration Register controls the connection to the USB bus, clock activity and power supply during 'suspend' state, output clock frequency, DMA operating mode and pin configurations (polarity, signalling mode).

Code (Hex): BA/BB — write/read Hardware Configuration Register

Transaction — write/read 1 word

Table 81: Hardware Configuration Register: bit allocation

Bit	15	14	13	12	11	10	9	8
Symbol	reserved	EXTPUL	NOLAZY	CLKRUN		CKDIV[3:0]		
Reset	0	0	1	0	0	0	1	1
Access	R/W	R/W	R/W	R/W	R/W	R/W	R/W	R/W

Bit	7	6	5	4	3	2	1	0
Symbol	DAKOLY	DRQPOL	DAKPOL	EOTPOL	WKUPCS	PWROFF	INTLVL	INTPOL
Reset	0	1	0	0	0	0	0	0
Access	R/W	R/W	R/W	R/W	R/W	R/W	R/W	R/W

Table 82: Hardware Configuration Register: bit description

Bit	Symbol	Description
15	-	reserved
14	EXTPUL	A logic 1 indicates that an external 1.5 kΩ pull-up resistor is used on pin D+ and that SoftConnect is not used. Bus reset value: unchanged.
13	NOLAZY	A logic 1 disables output on pin CLKOUT of the LazyClock frequency (115 kHz ±10 %) during 'suspend' state. A logic 0 causes pin CLKOUT to switch to LazyClock output after approximately 2 ms delay, following the setting of bit GOSUSP in the Mode Register. Bus reset value: unchanged.
12	CLKRUN	A logic 1 indicates that the internal clocks are always running, even during 'suspend' state. A logic 0 switches off the internal oscillator and PLL, when they are not needed. During 'suspend' state this bit must be made logic 0 to meet the suspend current requirements. The clock is stopped after a delay of approximately 2 ms, following the setting of bit GOSUSP in the Mode Register. Bus reset value: unchanged.
11 to 8	CKDIV[3:0]	This field specifies the clock division factor N, which controls the clock frequency on output CLKOUT. The output frequency in MHz is given by $48 / (N + 1)$. The clock frequency range is 3 to 48 MHz (N = 0 to 15). with a reset value of 12 MHz (N = 3). The hardware design guarantees no glitches during frequency change. Bus reset value: unchanged.
7	DAKOLY	A logic 1 selects DACK-only DMA mode. A logic 0 selects 8237 compatible DMA mode. Bus reset value: unchanged.
6	DRQPOL	Selects DREQ2 pin signal polarity (0 = active LOW, 1 = active HIGH). Bus reset value: unchanged.
5	DAKPOL	Selects DACK2 pin signal polarity (0 = active LOW, 1 = active HIGH). Bus reset value: unchanged.
4	EOTPOL	Selects EOT pin signal polarity (0 = active LOW, 1 = active HIGH). Bus reset value: unchanged.
3	WKUPCS	A logic 1 enables remote wake-up via a LOW level on input pin \overline{CS} . Bus reset value: unchanged.
2	PWROFF	A logic 1 enables powering-off during 'suspend' state. Output D_SUSPEND pin is configured as a power switch control signal for external devices (HIGH during 'suspend'). This value should always be initialized to logic 1. Bus reset value: unchanged.
1	INTLVL	Selects the interrupt signalling mode on output pin INT2 (0 = level, 1 = pulsed). In pulsed mode an interrupt produces an 166 ns pulse. See Section 8.6.3 for details. Bus reset value: unchanged.
0	INTPOL	Selects INT2 pin signal polarity (0 = active LOW, 1 = active HIGH). Bus reset value: unchanged.

14.1.5 Write/Read Interrupt Enable Register

This command is used to individually enable/disable interrupts from all endpoints, as well as interrupts caused by events on the USB bus (SOF, SOF lost, EOT, suspend, resume, reset). A bus reset will not change any of the programmed bit values.

The command accesses the Interrupt Enable Register, which consists of 4 bytes. The bit allocation is given in Table 83.

Code (Hex): C2/C3 — write/read Interrupt Enable Register

Transaction — write/read 2 words

Table 83: Interrupt Enable Register: bit allocation

Bit	31	30	29	28	27	26	25	24
Symbol	reserved							
Reset	0	0	0	0	0	0	0	0
Access	R/W	R/W	R/W	R/W	R/W	R/W	R/W	R/W
Bit	23	22	21	20	19	18	17	16
Symbol	IEP14	IEP13	IEP12	IEP11	IEP10	IEP9	IEP8	IEP7
Reset	0	0	0	0	0	0	0	0
Access	R/W	R/W	R/W	R/W	R/W	R/W	R/W	R/W
Bit	15	14	13	12	11	10	9	8
Symbol	IEP6	IEP5	IEP4	IEP3	IEP2	IEP1	IEP0IN	IEP0OUT
Reset	0	0	0	0	0	0	0	0
Access	R/W	R/W	R/W	R/W	R/W	R/W	R/W	R/W
Bit	7	6	5	4	3	2	1	0
Symbol	reserved	reserved	IEPSOF	IESOF	IEEOT	IESUSP	IERESM	IERST
Reset	0	0	0	0	0	0	0	0
Access	R/W	R/W	R/W	R/W	R/W	R/W	R/W	R/W

Table 84: Interrupt Enable Register: bit description

Bit	Symbol	Description
31 to 24	-	reserved; must write logic 0
23 to 10	IEP14 to IEP1	A logic 1 enables interrupts from the indicated endpoint.
9	IEP0IN	A logic 1 enables interrupts from the control IN endpoint.
8	IEP0OUT	A logic 1 enables interrupts from the control OUT endpoint.
7, 6	-	reserved
5	IEPSOF	A logic 1 enables 1 ms interrupts upon detection of Pseudo SOF.
4	IESOF	A logic 1 enables interrupt upon SOF detection.
3	IEEOT	A logic 1 enables interrupt upon EOT detection.
2	IESUSP	A logic 1 enables interrupt upon detection of 'suspend' state.
1	IERESM	A logic 1 enables interrupt upon detection of a 'resume' state.
0	IERST	A logic 1 enables interrupt upon detection of a bus reset.

14.1.6 Write/Read DMA Configuration

This command defines the DMA configuration of ISP1161's DC and enables/disables DMA transfers. The command accesses the DMA Configuration Register, which consists of 2 bytes. The bit allocation is given in Table 85. A bus reset will clear bit DMAEN (DMA disabled), all other bits remain unchanged.

Code (Hex): F0/F1 — write/read DMA Configuration

Transaction — write/read 1 word

Table 85: DMA Configuration Register: bit allocation

Bit	15	14	13	12	11	10	9	8
Symbol	CNTREN	SHORTP	reserved	reserved	reserved	reserved	reserved	reserved
Reset	0 ^[1]	0 ^[1]	0 ^[1]	0 ^[1]	0 ^[1]	0 ^[1]	0 ^[1]	0 ^[1]
Access	R/W	R/W	R/W	R/W	R/W	R/W	R/W	R/W
Bit	7	6	5	4	3	2	1	0
Symbol	EPDIX[3:0]				DMAEN	reserved	BURSTL[1:0]	
Reset	0 ^[1]	0 ^[1]	0 ^[1]	0 ^[1]	0	0	0 ^[1]	0 ^[1]
Access	R/W	R/W	R/W	R/W	R/W	R/W	R/W	R/W

[1] Unchanged by a bus reset.

Table 86: DMA Configuration Register: bit description

Bit	Symbol	Description
15	CNTREN	A logic 1 enables the generation of an EOT condition, when the DMA Counter Register reaches zero. Bus reset value: unchanged.
14	SHORTP	A logic 1 enables short/empty packet mode. When receiving (OUT endpoint) a short/empty packet an EOT condition is generated. When transmitting (IN endpoint) this bit should be cleared. Bus reset value: unchanged.
13 to 8	-	reserved
7 to 4	EPDIX[3:0]	Indicates the destination endpoint for DMA, see Table 10.
3	DMAEN	Writing a logic 1 enables DMA transfer, a logic 0 forces the end of an ongoing DMA transfer and generates an EOT interrupt. Reading this bit indicates whether DMA is enabled (0 = DMA stopped, 1 = DMA enabled). This bit is cleared by a bus reset.
2	-	reserved
1 to 0	BURSTL[1:0]	Selects the DMA burst length: 00 — single-cycle mode (1 byte) 01 — burst mode (4 bytes) 10 — burst mode (8 bytes) 11 — burst mode (16 bytes). Bus reset value: unchanged.

For selecting an endpoint for device DMA transfer, see Section 11.2.

14.1.7 Write/Read DMA Counter

This command accesses the DMA Counter Register. The bit allocation is given in [Table 87](#). Writing to the register sets the number of bytes for a DMA transfer. Reading the register returns the number of remaining bytes in the current transfer. A bus reset will not change the programmed bit values.

The internal DMA counter is automatically reloaded from the DMA Counter Register when DMA is re-enabled (DMAEN = 1). See [Section 14.1.6](#) for more details.

Code (Hex): F2/F3 — write/read DMA Counter Register

Transaction — write/read 1 word

Table 87: DMA Counter Register: bit allocation

Bit	15	14	13	12	11	10	9	8
Symbol	DMACR[15:8]							
Reset	0	0	0	0	0	0	0	0
Access	R/W	R/W	R/W	R/W	R/W	R/W	R/W	R/W
Bit	7	6	5	4	3	2	1	0
Symbol	DMACR[7:0]							
Reset	0	0	0	0	0	0	0	0
Access	R/W	R/W	R/W	R/W	R/W	R/W	R/W	R/W

Table 88: DMA Counter Register: bit description

Bit	Symbol	Description
15 to 0	DMACR[15:0]	DMA Counter Register

14.1.8 Reset Device

This command resets the ISP1161 DC in the same way as an external hardware reset via input $\overline{\text{RESET}}$. All registers are initialized to their 'reset' values.

Code (Hex): F6 — reset the device

Transaction — none

14.2 Data flow commands

Data flow commands are used to manage the data transmission between the USB endpoints and the system microprocessor. Much of the data flow is initiated via an interrupt to the microprocessor. The data flow commands are used to access the endpoints and determine whether the endpoint FIFOs contain valid data.

Remark: The IN buffer of an endpoint contains input data **for** the host, the OUT buffer receives output data **from** the host.

14.2.1 Write/Read Endpoint Buffer

This command is used to access endpoint FIFO buffers for reading or writing. First, the buffer pointer is reset to the beginning of the buffer. Following the command, a maximum of $(M + 1)$ words can be written or read, with M given by $(N + 1) \text{ DIV } 2$, N representing the size of the endpoint buffer. After each read/write action the buffer pointer is automatically incremented by 2.

In DMA access the first word (the packet length) is skipped: transfers start at the second word of the endpoint buffer. When reading, the ISP1161 DC can detect the last word via the End of Packet (EOP) condition. When writing to a bulk/interrupt endpoint, the endpoint buffer must be completely filled before sending the data to the host. Exception: when a DMA transfer is stopped by an external EOT condition, the current buffer content (full or not) is sent to the host.

Remark: Reading data after a Write Endpoint Buffer command or writing data after a Read Endpoint Buffer command will cause unpredictable behavior of the ISP1161 DC.

Code (Hex): 01 to 0F — write (control IN, endpoint 1 to 14)

Code (Hex): 10, 12 to 1F — read (control OUT, endpoint 1 to 14)

Transaction — write/read maximum $(M + 1)$ words (isochronous endpoint: $N \leq 1023$, bulk/interrupt endpoint: $N \leq 32$)

The data in the endpoint FIFO must be organized as shown in [Table 89](#). An example of endpoint FIFO access is given [Table 90](#).

Table 89: Endpoint FIFO organization

Word #	Description
0 (lower byte)	packet length (lower byte)
0 (upper byte)	packet length (upper byte)
1 (lower byte)	data byte 1
1 (upper byte)	data byte 2
...	...
$M = (N + 1) \text{ DIV } 2$	data byte N

Table 90: Example of endpoint FIFO access

A0	Phase	Bus lines	Word #	Description
1	command	D[7:0]	-	command code (00H to 1FH)
		D[15:8]	-	ignored
0	data	D[15:0]	0	packet length
0	data	D[15:0]	1	data word 1 (data byte 2, data byte 1)
0	data	D[15:0]	2	data word 2 (data byte 4, data byte 3)
...

Remark: There is no protection against writing or reading past a buffer's boundary or against writing into an OUT buffer or reading from an IN buffer. Any of these actions could cause an incorrect operation. Data residing in an OUT buffer are only

meaningful after a successful transaction. Exception: during DMA access of a double-buffered endpoint, the buffer pointer automatically points to the secondary buffer after reaching the end of the primary buffer.

14.2.2 Read Endpoint Status

This command is used to read the status of an endpoint FIFO. The command accesses the Endpoint Status Register, the bit allocation of which is shown in [Table 91](#). Reading the Endpoint Status Register will clear the interrupt bit set for the corresponding endpoint in the Interrupt Register (see [Table 106](#)).

All bits of the Endpoint Status Register are read-only. Bit EPSTAL is controlled by the Stall/Unstall commands and by the reception of a SETUP token (see [Section 14.2.3](#)).

Code (Hex): 50 to 5F — read (control OUT, control IN, endpoint 1 to 14)

Transaction — read 1 word

Table 91: Endpoint Status Register: bit allocation

Bit	7	6	5	4	3	2	1	0
Symbol	EPSTAL	EPFULL1	EPFULL0	DATA_PID	OVERWRITE	SETUPT	CPUBUF	reserved
Reset	0	0	0	0	0	0	0	0
Access	R	R	R	R	R	R	R	R

Table 92: Endpoint Status Register: bit description

Bit	Symbol	Description
7	EPSTAL	This bit indicates whether the endpoint is stalled or not (1 = stalled, 0 = not stalled). Set to logic 1 by a Stall Endpoint command, cleared to logic 0 by an Unstall Endpoint command. The endpoint is automatically unstalled upon reception of a SETUP token.
6	EPFULL1	A logic 1 indicates that the secondary endpoint buffer is full.
5	EPFULL0	A logic 1 indicates that the primary endpoint buffer is full.
4	DATA_PID	This bit indicates the data PID of the present packet (0 = DATA PID, 1 = DATA1 PID).
3	OVERWRITE	This bit is set by hardware, a logic 1 indicating that a new Setup packet has overwritten the previous setup information, before it was acknowledged or before the endpoint was stalled. This bit is cleared by reading, if writing the setup data has finished. Firmware must check this bit before sending an Acknowledge Setup command or stalling the endpoint. Upon reading a logic 1 the firmware must stop ongoing setup actions and wait for a new Setup packet.
2	SETUPT	A logic 1 indicates that the buffer contains a Setup packet.
1	CPUBUF	This bit indicates which buffer is currently selected for CPU access (0 = primary buffer, 1 = secondary buffer).
0	-	reserved

14.2.3 Stall Endpoint/Unstall Endpoint

These commands are used to stall or unstall an endpoint. The commands modify the content of the Endpoint Status Register (see [Table 91](#)).

A stalled control endpoint is automatically unstalled when it receives a SETUP token, regardless of the packet content. If the endpoint should stay in its stalled state, the microprocessor can re-stall it with the Stall Endpoint command.

When a stalled endpoint is unstalled (either by the Unstall Endpoint command or by receiving a SETUP token), it is also re-initialized. This flushes the buffer: in and if it is an OUT buffer it waits for a DATA 0 PID, if it is an IN buffer it writes a DATA 0 PID.

Code (Hex): 40 to 4F — stall (control OUT, control IN, endpoint 1 to 14)

Code (Hex): 80 to 8F — unstall (control OUT, control IN, endpoint 1 to 14)

Transaction — none

14.2.4 Validate Endpoint Buffer

This command signals the presence of valid data for transmission to the USB host, by setting the Buffer Full flag of the selected IN endpoint. This indicates that the data in the buffer is valid and can be sent to the host, when the next IN token is received. For a double-buffered endpoint this command switches the current FIFO for CPU access.

Remark: For special aspects of the control IN endpoint see [Section 11.3.6](#).

Code (Hex): 61 to 6F — validate endpoint buffer (control IN, endpoint 1 to 14)

Transaction — none

14.2.5 Clear Endpoint Buffer

This command unlocks and clears the buffer of the selected OUT endpoint, allowing the reception of new packets. Reception of a complete packet causes the Buffer Full flag of an OUT endpoint to be set. Any subsequent packets are refused by returning a NAK condition, until the buffer is unlocked using this command. For a double-buffered endpoint this command switches the current FIFO for CPU access.

Remark: For special aspects of the control OUT endpoint see [Section 11.3.6](#).

Code (Hex): 70, 72 to 7F — clear endpoint buffer (control OUT, endpoint 1 to 14)

Transaction — none

14.2.6 Check Endpoint Status

This command is used to check the status of the selected endpoint FIFO without clearing any status or interrupt bits. The command accesses the Endpoint Status Image Register, which contains a copy of the Endpoint Status Register. The bit allocation of the Endpoint Status Image Register is shown in [Table 93](#).

Code (Hex): D0 to DF — check status (control OUT, control IN, endpoint 1 to 14)

Transaction — write/read 1 word

Table 93: Endpoint Status Image Register: bit allocation

Bit	7	6	5	4	3	2	1	0
Symbol	EPSTAL	EPFULL1	EPFULL0	DATA_PID	OVERWRITE	SETUPT	CPUBUF	reserved
Reset	0	0	0	0	0	0	0	0
Access	R	R	R	R	R	R	R	R

Table 94: Endpoint Status Image Register: bit description

Bit	Symbol	Description
7	EPSTAL	This bit indicates whether the endpoint is stalled or not (1 = stalled, 0 = not stalled).
6	EPFULL1	A logic 1 indicates that the secondary endpoint buffer is full.
5	EPFULL0	A logic 1 indicates that the primary endpoint buffer is full.
4	DATA_PID	This bit indicates the data PID of the present packet (0 = DATA PID, 1 = DATA1 PID).
3	OVERWRITE	This bit is set by hardware, a logic 1 indicating that a new Setup packet has overwritten the previous setup information, before it was acknowledged or before the endpoint was stalled. This bit is cleared by reading, if writing the setup data has finished. Firmware must check this bit before sending an Acknowledge Setup command or stalling the endpoint. Upon reading a logic 1 the firmware must stop ongoing setup actions and wait for a new Setup packet.
2	SETUPT	A logic 1 indicates that the buffer contains a Setup packet.
1	CPUBUF	This bit indicates which buffer is currently selected for CPU access (0 = primary buffer, 1 = secondary buffer).
0	-	reserved

14.2.7 Acknowledge Setup

This command acknowledges to the host that a SETUP packet was received. The arrival of a SETUP packet disables the Validate Buffer and Clear Buffer commands for the control IN and OUT endpoints. The microprocessor needs to re-enable these commands by sending an Acknowledge Setup command, see [Section 11.3.6](#).

Remark: The Acknowledge Setup command must be sent to **both** control endpoints (IN and OUT).

Code (Hex): F4 — acknowledge setup

Transaction — none

14.3 General commands

14.3.1 Read Endpoint Error Code

This command returns the status of the last transaction of the selected endpoint, as stored in the Error Code Register. Each new transaction overwrites the previous status information. The bit allocation of the Error Code Register is shown in [Table 95](#).

Code (Hex): A0 to AF — read error code (control OUT, control IN, endpoint 1 to 14)

Transaction — read 1 word

Table 95: Error Code Register: bit allocation

Bit	7	6	5	4	3	2	1	0
Symbol	UNREAD	DATA01	reserved	ERROR[3:0]				RTOK
Reset	0	0	0	0	0	0	0	0
Access	R	R	R	R	R	R	R	R

Table 96: Error Code Register: bit description

Bit	Symbol	Description
7	UNREAD	A logic 1 indicates that a new event occurred before the previous status was read.
6	DATA01	This bit indicates the PID type of the last successfully received or transmitted packet (0 = DATA0 PID, 1 = DATA1 PID).
5	-	reserved
4 to 1	ERROR[3:0]	Error code. For error description, see Table 97 .
0	RTOK	A logic 1 indicates that data was received or transmitted successfully.

Table 97: Transaction error codes

Error code (Binary)	Description
0000	no error
0001	PID encoding error; bits 7 to 4 are not the inverse of bits 3 to 0
0010	PID unknown; encoding is valid, but PID does not exist
0011	unexpected packet; packet is not of the expected type (token, data, or acknowledge), or is a SETUP token to a non-control endpoint
0100	token CRC error
0101	data CRC error
0110	time-out error
0111	babble error
1000	unexpected end-of-packet
1001	sent or received NAK (Not AcKnowledge)
1010	sent Stall; a token was received, but the endpoint was stalled
1011	overflow; the received packet was larger than the available buffer space
1100	sent empty packet (ISO only)
1101	bit stuffing error
1110	sync error
1111	wrong (unexpected) toggle bit in DATA PID; data was ignored

14.3.2 Unlock Device

This command unlocks ISP1161’s DC from write-protection mode after a ‘resume’. In ‘suspend’ state all registers and FIFOs are write-protected to prevent data corruption by external devices during a ‘resume’. Register access for reading is not blocked.

After waking up from ‘suspend’ state, the firmware must unlock the registers and FIFOs via this command, by writing the unlock code (AA37H) into the Lock Register. The bit allocation of the Lock Register is given in [Table 98](#).

Code (Hex): B0 — unlock the device

Transaction — write 1 word (unlock code)

Table 98: Lock Register: bit allocation

Bit	15	14	13	12	11	10	9	8
Symbol	UNLOCKH[7:0] = AAH							
Reset	1	0	1	0	1	0	1	0
Access	W	W	W	W	W	W	W	W
Bit	7	6	5	4	3	2	1	0
Symbol	UNLOCKL[7:0] = 37H							
Reset	0	0	1	1	0	1	1	1
Access	W	W	W	W	W	W	W	W

Table 99: Lock Register: bit description

Bit	Symbol	Description
15 to 0	UNLOCK[15:0]	Sending data AA37H unlocks the internal registers and FIFOs for writing, following a ‘resume’.

14.3.3 Write/Read Scratch Register

This command accesses the 16-bit Scratch Register, which can be used by the firmware to save and restore information, e.g., the device status before powering down in ‘suspend’ state. The register bit allocation is given in [Table 100](#).

Code (Hex): B2/B3 — write/read Scratch Register

Transaction — write/read 1 word

Table 100: Scratch Information Register: bit allocation

Bit	15	14	13	12	11	10	9	8
Symbol	reserved	SFIRH[6:0]						
Reset	0	0	0	0	0	0	0	0
Access	R/W	R/W	R/W	R/W	R/W	R/W	R/W	R/W
Bit	7	6	5	4	3	2	1	0
Symbol	SFIRL[7:0]							
Reset	0	0	0	0	0	0	0	0
Access	R/W	R/W	R/W	R/W	R/W	R/W	R/W	R/W

Table 101: Scratch Information Register: bit description

Bit	Symbol	Description
15	-	reserved; must be logic 0
14 to 0	SFIR[14:0]	Scratch Information Register

14.3.4 Read Frame Number

This command returns the frame number of the last successfully received SOF. It is followed by reading one word from the Frame Number Register, containing the frame number. The Frame Number Register is shown in Table 102.

Remark: After a bus reset, the value of the frame Number Register is undefined.

Code (Hex): B4 — read frame number

Transaction — read 1 word

Table 102: Frame Number Register: bit allocation

Bit	15	14	13	12	11	10	9	8
Symbol	reserved	reserved	reserved	reserved	reserved	SOFRH[2:0]		
Reset^[1]	0	0	0	0	0	0	0	0
Access	R	R	R	R	R	R	R	R
Bit	7	6	5	4	3	2	1	0
Symbol	SOFRL[7:0]							
Reset^[1]	0	0	0	0	0	0	0	0
Access	R	R	R	R	R	R	R	R

[1] Reset value undefined after a bus reset.

Table 103: Example of Frame Number Register access

A0	Phase	Bus lines	Word #	Description
1	command	D[7:0]	-	command code (B4H)
		D[15:8]	-	ignored
0	data	D[15:0]	0	frame number

14.3.5 Read Chip ID

This command reads the chip identification code and hardware version number. The firmware must check this information to determine the supported functions and features. This command accesses the Chip ID Register, which is shown in Table 104.

Code (Hex): B5 — read chip ID

Transaction — read 1 word

Table 104: Chip ID Register: bit allocation

Bit	15	14	13	12	11	10	9	8
Symbol	CHIPIDH[7:0]							
Reset	0	1	1	0	0	0	0	1
Access	R	R	R	R	R	R	R	R
Bit	7	6	5	4	3	2	1	0
Symbol	CHIPIDL[7:0]							
Reset	X0H							
Access	R	R	R	R	R	R	R	R

Table 105: Chip ID Register: bit description

Bit	Symbol	Description
15 to 8	CHIPIDH[7:0]	chip ID code (61H)
7 to 0	CHIPIDL[7:0]	silicon version (XXH, with XX representing the BCD encoded version number)

14.3.6 Read Interrupt Register

This command indicates the sources of interrupts as stored in the 4-byte Interrupt Register. Each individual endpoint has its own interrupt bit. The bit allocation of the Interrupt Register is shown in [Table 106](#). Bit BUSTATUS is used to verify the current bus status in the interrupt service routine. Interrupts are enabled via the Interrupt Enable Register, see [Section 14.1.5](#).

While reading the interrupt register, please read both 2 bytes completely.

Code (Hex): C0 — read interrupt register

Transaction — read 2 words

Table 106: Interrupt Register: bit allocation

Bit	31	30	29	28	27	26	25	24
Symbol	reserved	reserved	reserved	reserved	reserved	reserved	reserved	reserved
Reset	0	0	0	0	0	0	0	0
Access	R	R	R	R	R	R	R	R
Bit	23	22	21	20	19	18	17	16
Symbol	EP14	EP13	EP12	EP11	EP10	EP9	EP8	EP7
Reset	0	0	0	0	0	0	0	0
Access	R	R	R	R	R	R	R	R
Bit	15	14	13	12	11	10	9	8
Symbol	EP6	EP5	EP4	EP3	EP2	EP1	EP0IN	EP0OUT
Reset	0	0	0	0	0	0	0	0
Access	R	R	R	R	R	R	R	R
Bit	7	6	5	4	3	2	1	0
Symbol	BUSTATUS	reserved	PSOF	SOF	EOT	SUSPND	RESUME	RESET
Reset	0	0	0	0	0	0	0	0
Access	R	R	R	R	R	R	R	R

Table 107: Interrupt Register: bit description

Bit	Symbol	Description
31 to 24	-	reserved
23 to 10	EP14 to EP1	A logic 1 indicates the interrupt source(s): endpoint 14 to 1
9	EP0IN	A logic 1 indicates the interrupt source: control IN endpoint
8	EP0OUT	A logic 1 indicates the interrupt source: control OUT endpoint
7	BUSTATUS	Monitors the current USB bus status (0 = awake, 1 = suspend).
6	-	reserved

Table 107: Interrupt Register: bit description...continued

Bit	Symbol	Description
5	PSOF	A logic 1 indicates that an interrupt is issued every 1 ms because of the Pseudo SOF; after 3 missed SOFs 'suspend' state is entered.
4	SOF	A logic 1 indicates that a SOF condition was detected.
3	EOT	A logic 1 indicates that an internal EOT condition was generated by the DMA Counter reaching zero.
2	SUSPND	A logic 1 indicates that an 'awake' to 'suspend' change of state was detected on the USB bus.
1	RESUME	A logic 1 indicates that a 'resume' state was detected.
0	RESET	A logic 1 indicates that a bus reset condition was detected.

15. Reset

Pin $\overline{\text{RESET}}$ is the hardware reset input of ISP1161. It is active LOW. To reset all internal logic, the minimum timing requirement is 200 ns.

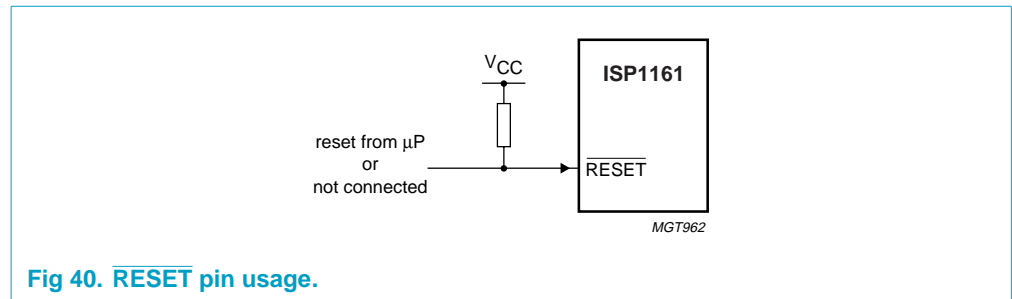

Fig 40. RESET pin usage.

16. Power supply

ISP1161 can operate at either +5 V or +3.3 V.

When using +5 V as ISP1161's power supply input: Only V_{CC} (pin 56) can be connected to the +5 V power supply. An application with a +5 V power supply input is shown in Figure 41. ISP1161 has an internal DC/DC regulator to provide +3.3 V for its internal core. This internal +3.3 V can also be obtained from $V_{reg(3.3)}$ (pin 58) to supply the 1.5 kΩ pull-up resistor of the DC side upstream port signal D_DP. The signal D_DP is connected to the standard USB upstream port connector's pin D+.

When using +3.3 V as the power supply input, the internal DC/DC regulator will be bypassed. All four power supply pins (V_{CC} , $V_{reg(3.3)}$, V_{hold1} and V_{hold2}) can be used as power supply input.

The best case is to connect all four power supply pins to the +3.3 V power supply, as shown in Figure 42. If, however you do not want to connect all four, you must at least, connect the V_{CC} and the $V_{reg(3.3)}$ to the 3.3 V power supply.

For both +3.3 V and 5 V operation, all four power supply pins should be connected to a decoupling capacitor.

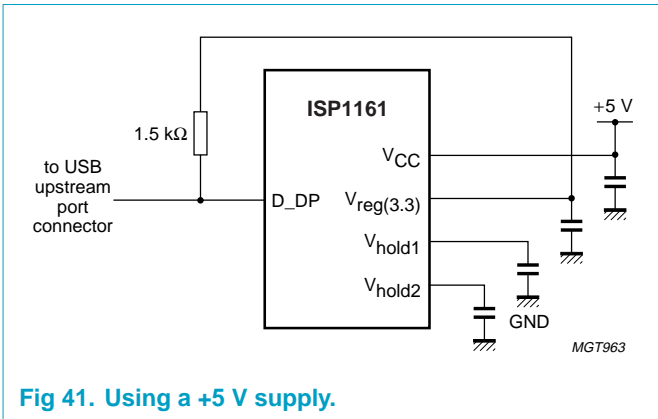

Fig 41. Using a +5 V supply.

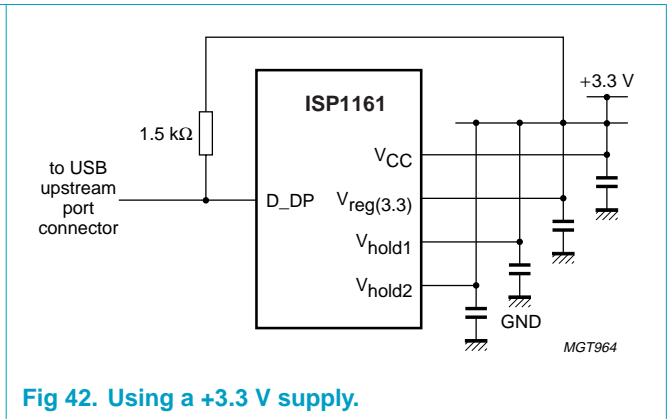

Fig 42. Using a +3.3 V supply.

17. External clock input

The ISP1161 has a crystal oscillator designed for a 6 MHz parallel-resonant crystal (fundamental). A typical circuit is shown in [Figure 43](#). Alternatively, an external clock signal of 6 MHz can be applied to input XTAL1, while leaving output XTAL2 open. See [Figure 44](#).

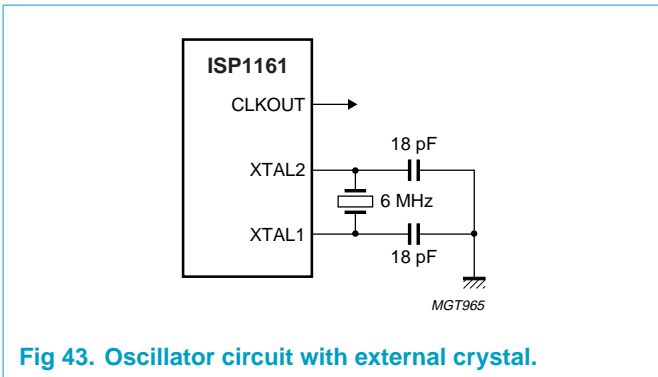

Fig 43. Oscillator circuit with external crystal.

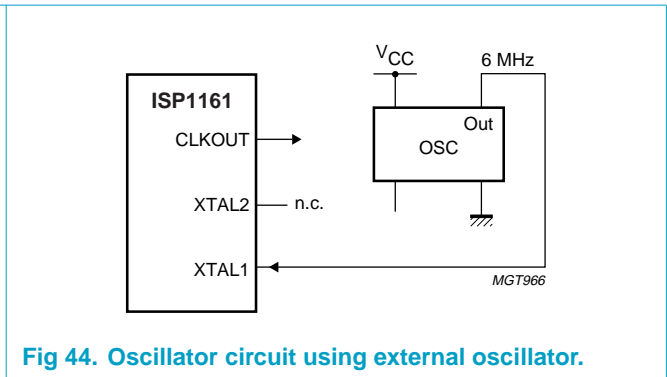

Fig 44. Oscillator circuit using external oscillator.

The 6 MHz oscillator frequency is multiplied to 48 MHz by an internal PLL. This frequency is used to generate a programmable clock output signal at pin CLKOUT, ranging from 3 to 48 MHz.

18. Limiting values

Table 108: Absolute maximum ratings

In accordance with the Absolute Maximum Rating System (IEC 60134).

Symbol	Parameter	Conditions	Min	Max	Unit
$V_{CC(5V)}$	supply voltage to V_{CC} pin		-0.5	+6.0	V
$V_{CC(3.3V)}$	supply voltage to $V_{reg(3.3)}$ pin		-0.5	+4.6	V
V_I	input voltage		-0.5	+6.0	V
$I_{latchup}$	latchup current	$V_I < 0$ or $V_I > V_{CC}$	-	100	mA
V_{esd}	electrostatic discharge voltage	$I_{LI} < 10 \mu A$	[1][2] -	± 2000	V
T_{stg}	storage temperature		-60	+150	$^{\circ}C$

[1] Equivalent to discharging a 100 pF capacitor via a 1.5 k Ω resistor (Human Body Model).

[2] Values are given for device only; in-circuit $V_{esd(max)} = \pm 8000$ V.

Table 109: Recommended operating conditions

Symbol	Parameter	Conditions	Min	Typ	Max	Unit
V_{CC}	supply voltage	with internal regulator	4.0	5.0	5.5	V
		internal regulator bypass	3.0	3.3	3.6	V
V_I	input voltage		0	V_{CC}	5.5 ^[1]	V
$V_{I(A\ I/O)}$	input voltage on analog I/O pins (D+ / D-)		0	-	3.6	V
$V_{O(od)}$	open-drain output pull-up voltage		0	-	V_{CC}	V
T_{amb}	operating ambient temperature		-40	-	+85	$^{\circ}C$

[1] 5 V tolerant.

19. Static characteristics

Table 110: Static characteristics; supply pins

$V_{CC} = 3.0$ to 3.6 V or 4.0 to 5.5 V; $V_{GND} = 0$ V; $T_{amb} = -40$ to $+85$ °C; unless otherwise specified.

Symbol	Parameter	Conditions	Min	Typ	Max	Unit
$V_{CC} = +5$ V						
$V_{reg(3.3)}$	internal regulator output		3.0 ^[1]	3.3	3.6	V
I_{CC}	operating supply current		-	47	-	mA
$I_{CC(susp)}$	suspend supply current		-	40	500	µA
$I_{CC(HC)}$	operating supply current for HC	DC is suspended	-	22	-	mA
$I_{CC(DC)}$	operating supply current for DC	HC is suspended	-	18	-	mA
$V_{CC} = +3.3$ V						
I_{CC}	operating supply current		-	50	-	mA
$I_{CC(susp)}$	suspend supply current		-	150	-	µA
$I_{CC(HC)}$	operating supply current for HC	DC is suspended	-	22	-	mA
$I_{CC(DC)}$	operating supply current for DC	HC is suspended	-	18	-	mA

[1] In suspend mode, the minimum voltage is 2.7 V.

Table 111: Static characteristics: digital pins

$V_{CC} = 3.0$ to 3.6 V or 4.0 to 5.5 V; $V_{GND} = 0$ V; $T_{amb} = -40$ to $+85$ °C; unless otherwise specified.

Symbol	Parameter	Conditions	Min	Typ	Max	Unit
Input levels						
V_{IL}	LOW-level input voltage		-	-	0.8	V
V_{IH}	HIGH-level input voltage		2.0	-	-	V
Schmitt trigger inputs						
$V_{th(LH)}$	positive-going threshold voltage		1.4	-	1.9	V
$V_{th(HL)}$	negative-going threshold voltage		0.9	-	1.5	V
V_{hys}	hysteresis voltage		0.4	-	0.7	V
Output levels						
V_{OL}	LOW-level output voltage	$I_{OL} = \text{rated drive}$	-	-	0.4	V
		$I_{OL} = 20 \mu\text{A}$	-	-	0.1	V
V_{OH}	HIGH-level output voltage	$I_{OH} = \text{rated drive}$	^[1] 2.4	-	-	V
		$I_{OH} = 20 \mu\text{A}$	$V_{reg(3.3)} - 0.1$	-	-	V
Leakage current						
I_{LI}	input leakage current		-	-	±5	µA
C_{IN}	pin capacitance	pin to GND	-	-	5	pF
Open-drain outputs						
I_{OZ}	OFF-state output current		-	-	±5	µA

[1] Not applicable for open-drain outputs.

Table 112: Static characteristics: analog I/O pins (D+, D-) $V_{CC} = 3.0$ to 3.6 V or 4.0 to 5.5 V; $V_{GND} = 0$ V; $T_{amb} = -40$ to $+85$ °C; unless otherwise specified.

Symbol	Parameter	Conditions	Min	Typ	Max	Unit
Input levels						
V_{DI}	differential input sensitivity	$ V_{I(D+)} - V_{I(D-)} $	[1] 0.2	-	-	V
V_{CM}	differential common mode voltage	includes V_{DI} range	0.8	-	2.5	V
V_{IL}	LOW-level input voltage		-	-	0.8	V
V_{IH}	HIGH-level input voltage		2.0	-	-	V
Output levels						
V_{OL}	LOW-level output voltage	$R_L = 1.5$ k Ω to $+3.6$ V	-	-	0.3	V
V_{OH}	HIGH-level output voltage	$R_L = 15$ k Ω to GND	2.8	-	3.6	V
Leakage current						
I_{LZ}	OFF-state leakage current		-	-	± 10	μ A
Capacitance						
C_{IN}	transceiver capacitance	pin to GND	-	-	10	pF
Resistance						
R_{PD}	pull-down resistance on HC's DP/DM	enable internal resistors	11	-	19	k Ω
R_{PU}	pull-up resistance on D_DP	SoftConnect = ON	1.1	-	1.9	k Ω
Z_{DRV}	driver output impedance	steady-state drive	[2] 29	-	44	Ω
Z_{INP}	input impedance		10	-	-	M Ω
Termination						
V_{TERM}	termination voltage for upstream port pull-up (R_{PU})		3.0 [3]	-	3.6	V

[1] D+ is the USB positive data pin; D- is the USB negative data pin.

[2] Includes external resistors of $18 \Omega \pm 1\%$ on both H_D+ and H_D-.

[3] In suspend mode, the minimum voltage is 2.7 V.

20. Dynamic characteristics

Table 113: Dynamic characteristics

$V_{CC} = 3.0$ to 3.6 V or 4.0 to 5.5 V; $V_{GND} = 0$ V; $T_{amb} = -40$ to $+85$ °C; unless otherwise specified.

Symbol	Parameter	Conditions	Min	Typ	Max	Unit
Reset						
$t_{W(\overline{RESET})}$	pulse width on input \overline{RESET}	crystal oscillator running	50	-	-	μ s
		crystal oscillator stopped	-	[1]	-	ms
Crystal oscillator						
f_{XTAL}	crystal frequency		-	6	-	MHz

[1] Dependent on the crystal oscillator start-up time.

Table 114: Dynamic characteristics: analog I/O pins (D+, D-) [1]

$V_{CC} = 3.0$ to 3.6 V or 4.0 to 5.5 V; $V_{GND} = 0$ V; $T_{amb} = -40$ to $+85$ °C; $C_L = 50$ pF; $R_{PU} = 1.5$ k Ω \pm 5% on D+ to V_{TERM} ; unless otherwise specified.

Symbol	Parameter	Conditions	Min	Typ	Max	Unit
Driver characteristics						
t_{FR}	rise time	$C_L = 50$ pF; 10 to 90% of $ V_{OH} - V_{OL} $	4	-	20	ns
t_{FF}	fall time	$C_L = 50$ pF; 90 to 10% of $ V_{OH} - V_{OL} $	4	-	20	ns
FRFM	differential rise/fall time matching (t_{FR}/t_{FF})		[2] 90	-	111.11	%
V_{CRS}	output signal crossover voltage		[2][3] 1.3	-	2.0	V

[1] Test circuit; see [Figure 57](#).

[2] Excluding the first transition from Idle state.

[3] Characterized only, not tested. Limits guaranteed by design.

20.1 Timing symbols

Table 115: Legend for timing characteristics

Symbol	Description
Time symbols	
t	time
T	cycle time (periodic signal)
Signal names	
A	address; DMA acknowledge (DACK)
C	clock; command
D	data input; data
E	chip enable
G	output enable
I	instruction (program memory content); input (general)
L	address latch enable (ALE)
P	program store enable ($\overline{\text{PSEN}}$, active LOW); propagation delay
Q	data output
R	read signal ($\overline{\text{RD}}$, active LOW); read (action); DMA request (DREQ)
S	chip select
W	write signal ($\overline{\text{WR}}$, active LOW); write (action); pulse width
U	undefined
Y	output (general)
Logic levels	
H	logic HIGH
L	logic LOW
P	stop, not active (OFF)
S	start, active (ON)
V	valid logic level
X	invalid logic level
Z	high-impedance (floating, three-state)

20.2 Parallel I/O timing

Table 116: Dynamic characteristics: parallel interface timing

Symbol	Parameter	Conditions	16-bit bus		Unit
			Min	Max	
Read timing					
t_{SHSL}	first $\overline{RD}/\overline{WR}$ after CMD		300	-	ns
t_{SLRL}	\overline{CS} LOW to \overline{RD} LOW		0	-	ns
t_{RHSH}	\overline{RD} HIGH to \overline{CS} HIGH		0	-	ns
t_{RL}	\overline{RD} LOW pulse width		33	-	ns
t_{RHRL}	\overline{RD} HIGH to next \overline{RD} LOW		110	-	ns
t_{RC}	\overline{RD} cycle		143	-	ns
t_{RHDZ}	\overline{RD} data hold time		3	-	ns
t_{RLDV}	\overline{RD} LOW to data valid		32	-	ns
Write timing					
t_{WL}	\overline{WR} LOW pulse width		26	-	ns
t_{WHWL}	\overline{WR} HIGH to next \overline{WR} LOW		110	-	ns
t_{WC}	\overline{WR} cycle		136	-	ns
t_{SLWL}	\overline{CS} LOW to \overline{WR} LOW		0	-	ns
t_{WHSH}	\overline{WR} HIGH to \overline{CS} HIGH		0	-	ns
t_{WDSU}	\overline{WR} data setup time		5	-	ns
t_{WDH}	\overline{WR} data hold time		8	-	

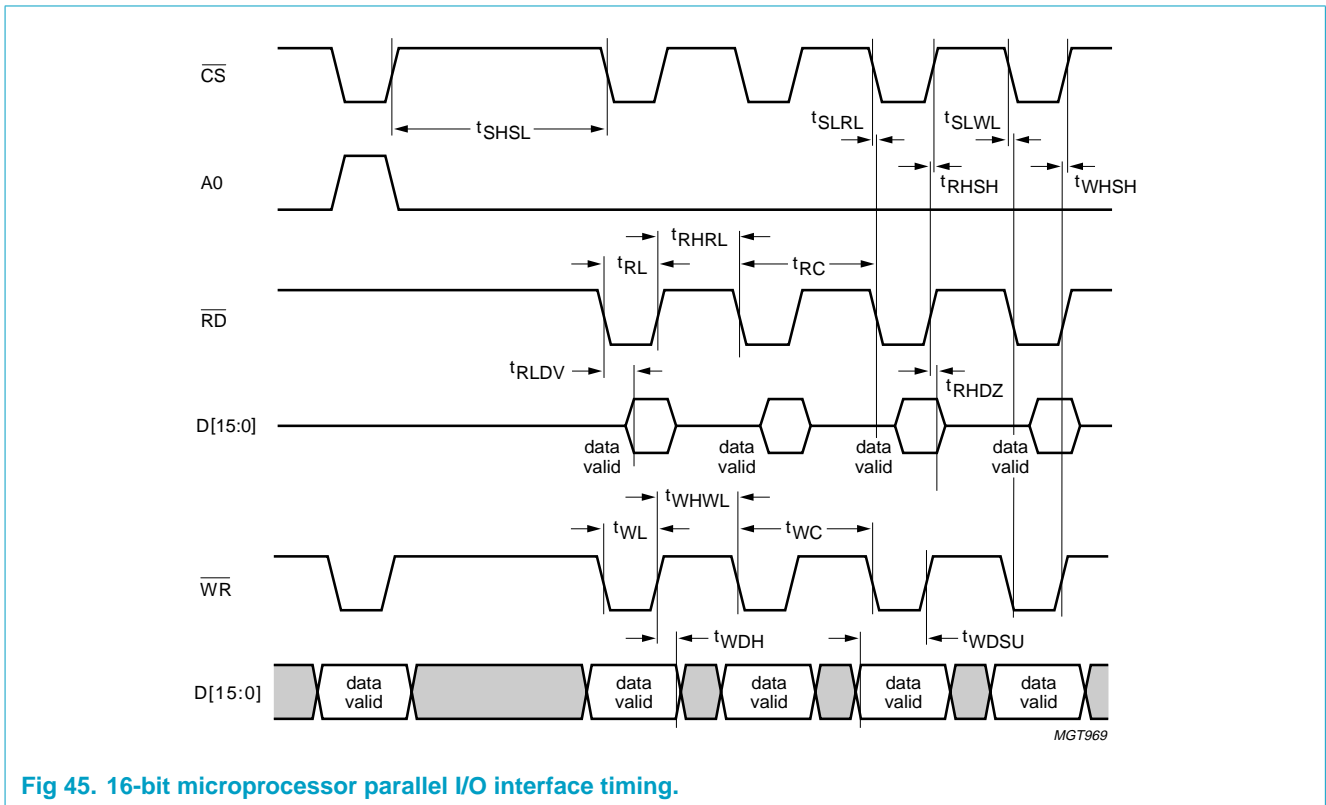

Fig 45. 16-bit microprocessor parallel I/O interface timing.

20.3 DMA interface timing

20.3.1 HC single-cycle burst mode DMA timing

Table 117: Dynamic characteristics: HC single-cycle burst mode DMA timing

Symbol	Parameter	Conditions	16-bit bus		Unit
			Min	Max	
Read/write timing					
t_{RL}	\overline{RD} pulse width		33	-	ns
t_{RLDV}	read process data setup time		26	-	ns
t_{RHDZ}	read process data hold time		0	-	ns
t_{WSU}	write process data setup time		5	-	ns
t_{WHD}	write process data hold time		0	-	ns
t_{AHRH}	DACK1 HIGH to DREQ1 HIGH		62 to 81	-	ns
t_{ALRL}	DACK1 LOW to DREQ1 LOW		-	21	ns
t_{DC}	DREQ1 cycle		[1]	-	ns
t_{SHAH}	$\overline{RD}/\overline{WR}$ HIGH to DACK1 HIGH		> 0	-	ns
t_{RHAL}	DREQ1 HIGH to DACK1 LOW		> 0	-	ns
t_{DS}	DREQ1 pulse spacing		125 to 146	-	ns

[1] $t_{RHAL} + t_{DS} + t_{ALRL}$.

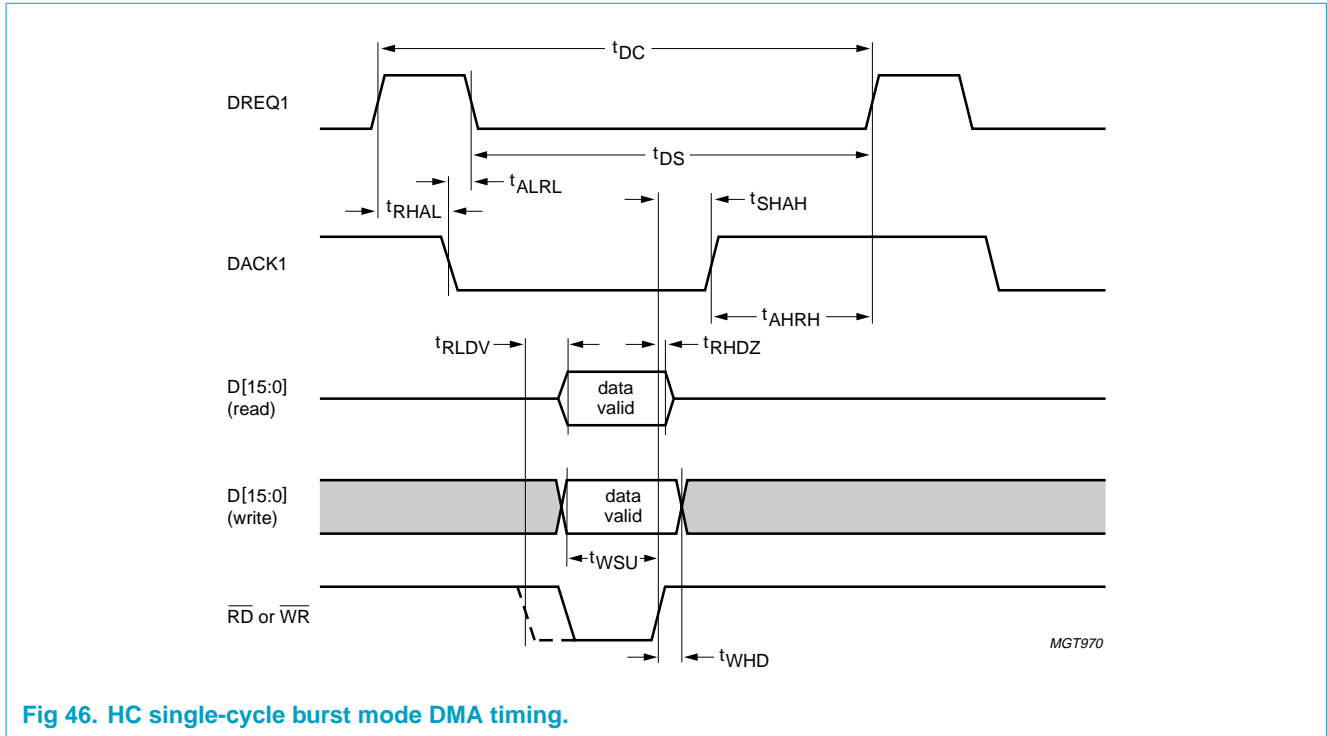

Fig 46. HC single-cycle burst mode DMA timing.

20.3.2 HC multi-cycle burst mode DMA timing

Table 118: Dynamic characteristics: HC multi-cycle burst mode DMA timing

Symbol	Parameter	Conditions	16-bit bus		Unit
			Min	Max	
Read/write timing (for 4-cycle and 8-cycle burst mode)					
t_{RL}	$\overline{WR/RD}$ LOW pulse width		42	-	ns
t_{RHRL}	$\overline{WR/RD}$ HIGH to next $\overline{WR/RD}$ LOW		60	-	ns
t_{RC}	$\overline{WR/RD}$ cycle		102	-	ns
t_{SLRL}	$\overline{RD/WR}$ LOW to DREQ1 LOW		22	64	ns
t_{SHAH}	$\overline{RD/WR}$ HIGH to DACK1 HIGH		> 0	-	ns
t_{RHAL}	DREQ1 HIGH to DACK1 LOW		> 0	-	ns
t_{DC}	DREQ1 cycle		[1]	-	ns
$t_{DS(read)}$	DREQ1 pulse spacing (read)	4-cycle burst mode	105	-	
$t_{DS(read)}$	DREQ1 pulse spacing (read)	8-cycle burst mode	150	-	
$t_{DS(write)}$	DREQ1 pulse spacing (write)	4-cycle burst mode	62 to 84	-	ns
$t_{DS(write)}$	DREQ1 pulse spacing (write)	8-cycle burst mode	150 to 167	-	ns

[1] $t_{SLAL} + (4 \text{ or } 8)t_{RC} + t_{DS}$.

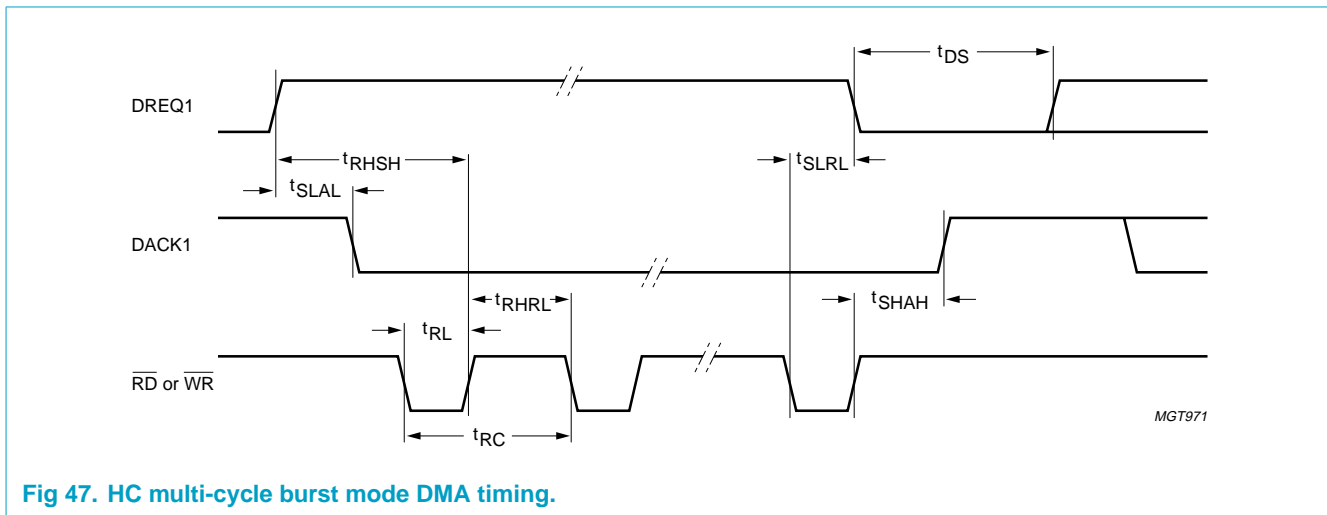

Fig 47. HC multi-cycle burst mode DMA timing.

20.3.3 External EOT timing for HC single-cycle burst mode DMA

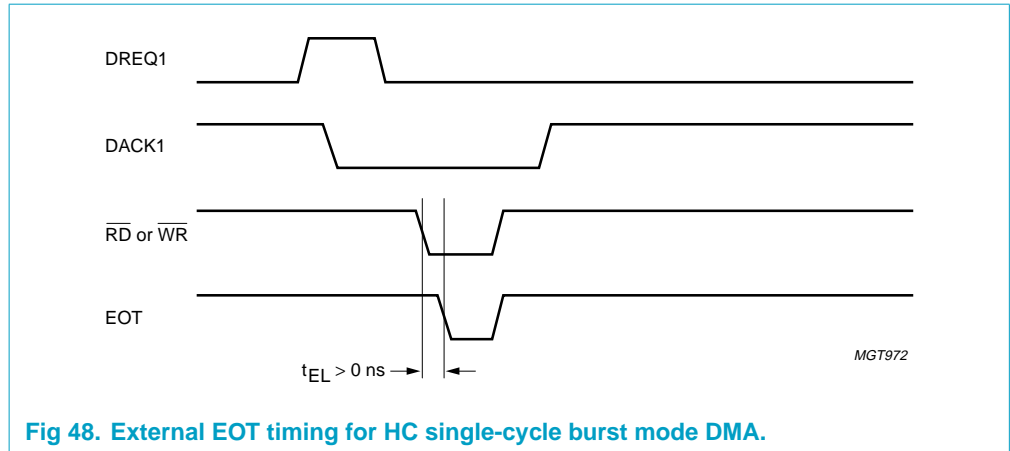

Fig 48. External EOT timing for HC single-cycle burst mode DMA.

20.3.4 External EOT timing for HC multi-cycle burst mode DMA

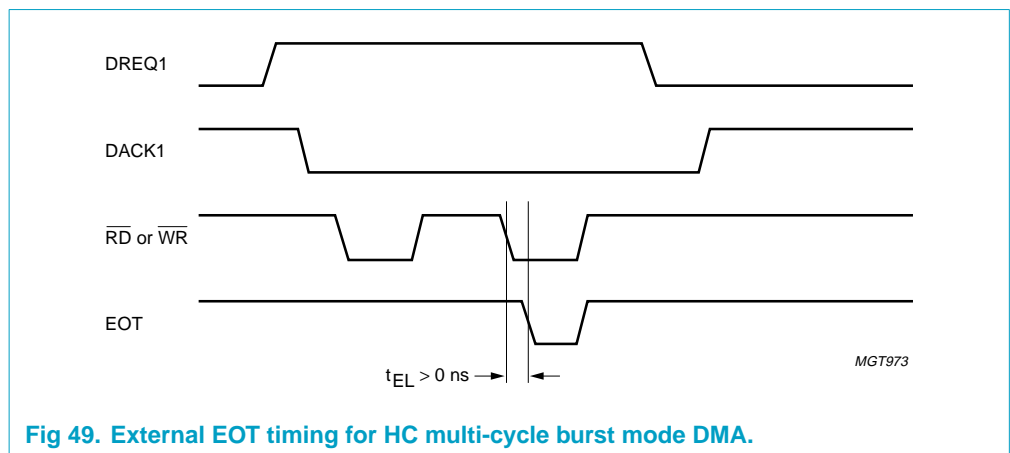

Fig 49. External EOT timing for HC multi-cycle burst mode DMA.

20.3.5 DC single-cycle DMA timing (8237 mode)

Table 119: Dynamic characteristics: DC single-cycle DMA timing (8237 mode)

Symbol	Parameter	Conditions	Min	Typ	Max	Unit
t_{ALRL}	DACK2 ON to DREQ2 OFF		-	-	40	ns
t_{AHRH}	DACK2 OFF to DREQ2 ON		-	-	22	ns

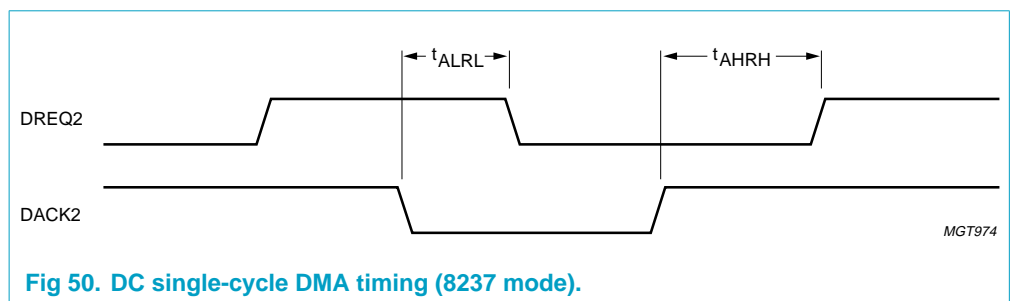

Fig 50. DC single-cycle DMA timing (8237 mode).

20.3.6 DC single-cycle DMA timing (DACK-only mode)

Table 120: Dynamic characteristics: DC single-cycle DMA timing (DACK-only mode)

Symbol	Parameter	Conditions	Min	Typ	Max	Unit
t_{ALRL}	DACK2 ON to DREQ2 OFF		-	-	40	ns
t_{AHRH}	DACK2 OFF to DREQ2 ON		-	-	22	ns
t_{ALDV}	DACK2 ON to data valid		-	-	22	ns
t_{AHDZ}	DACK2 OFF to data invalid		-	-	3	ns

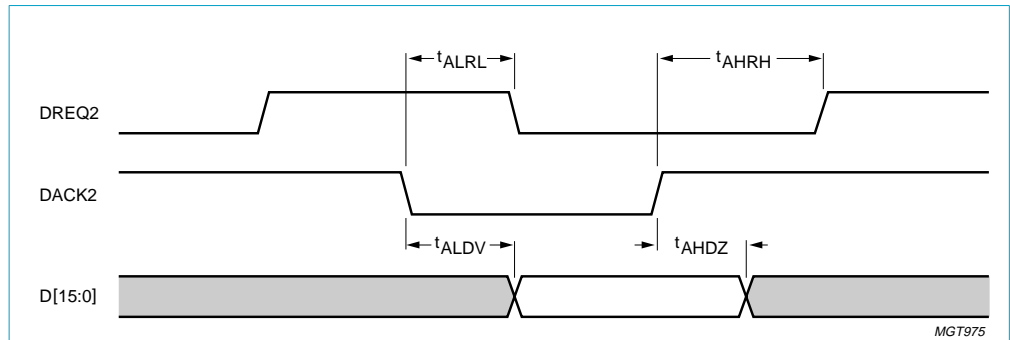

Fig 51. DC single-cycle DMA timing (DACK-only mode).

20.3.7 EOT timing for DC single-cycle DMA timing

Table 121: Dynamic characteristics: EOT timing for DC single-cycle DMA timing

Symbol	Parameter	Conditions	Min	Typ	Max	Unit
t_{RHSH}	DREQ2 ON to $\overline{RD}/\overline{WR}$ OFF		22	-	-	ns
t_{AHRH}	DACK2 OFF to DREQ2 ON		-	-	22	ns
t_{SHAH}	$\overline{RD}/\overline{WR}$ OFF to DACK2 OFF		0	-	-	ns
t_{EL}	EOT pulse width		22	-	-	ns

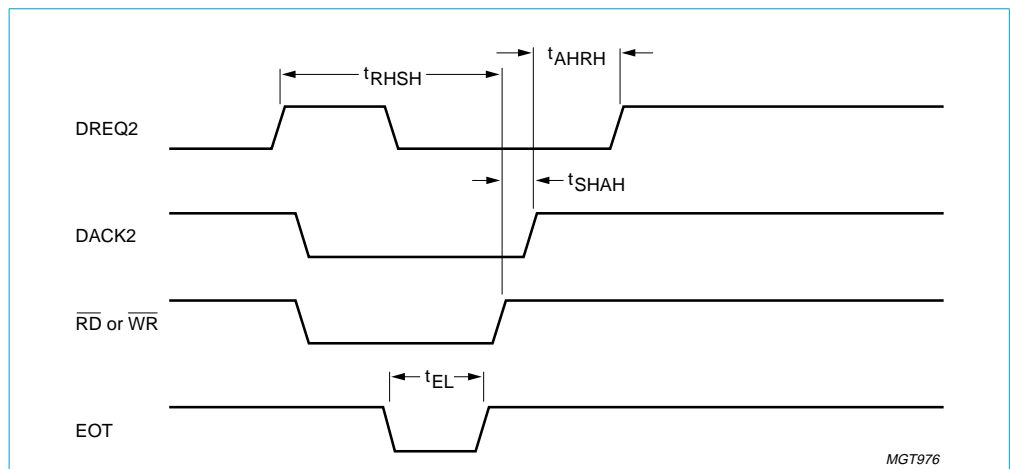

Fig 52. EOT timing for DC single-cycle DMA timing.

20.3.8 DC multi-cycle burst mode DMA timing

Table 122: Dynamic characteristics: DC multi-cycle burst mode DMA timing

Symbol	Parameter	Conditions	Min	Typ	Max	Unit
t_{RHSH}	DREQ2 ON to first $\overline{RD}/\overline{WR}$ OFF		22	-	-	ns
t_{SLRL}	last $\overline{RD}/\overline{WR}$ ON to DREQ2 OFF		-	-	60	ns
t_{SHAH}	last $\overline{RD}/\overline{WR}$ OFF to DACK2 OFF		0	-	-	ns
t_{RHRL}	DMA burst repeat interval		180	-	-	ns

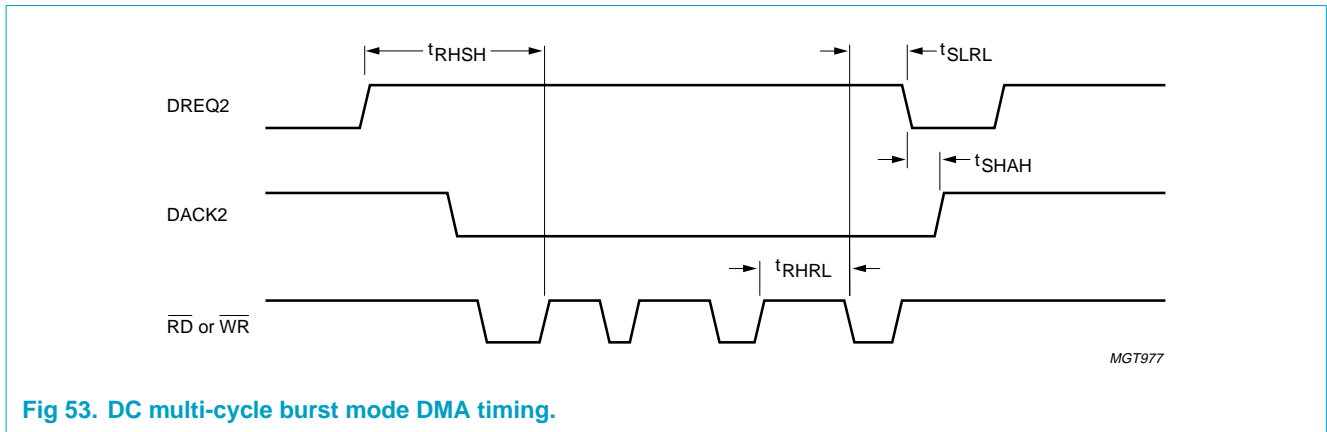

Fig 53. DC multi-cycle burst mode DMA timing.

20.3.9 DMA terminated by EOT

Table 123: Dynamic characteristics: DMA terminated by EOT

Symbol	Parameter	Conditions	Min	Typ	Max	Unit
t_{ELRL}	EOT ON to DREQ2 OFF		-	-	40	ns

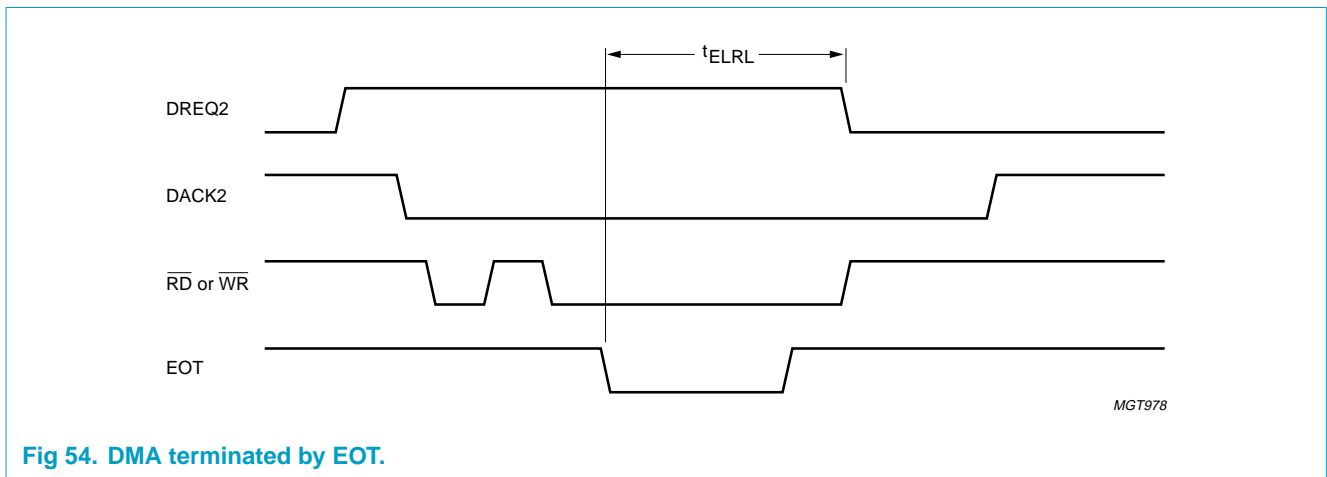
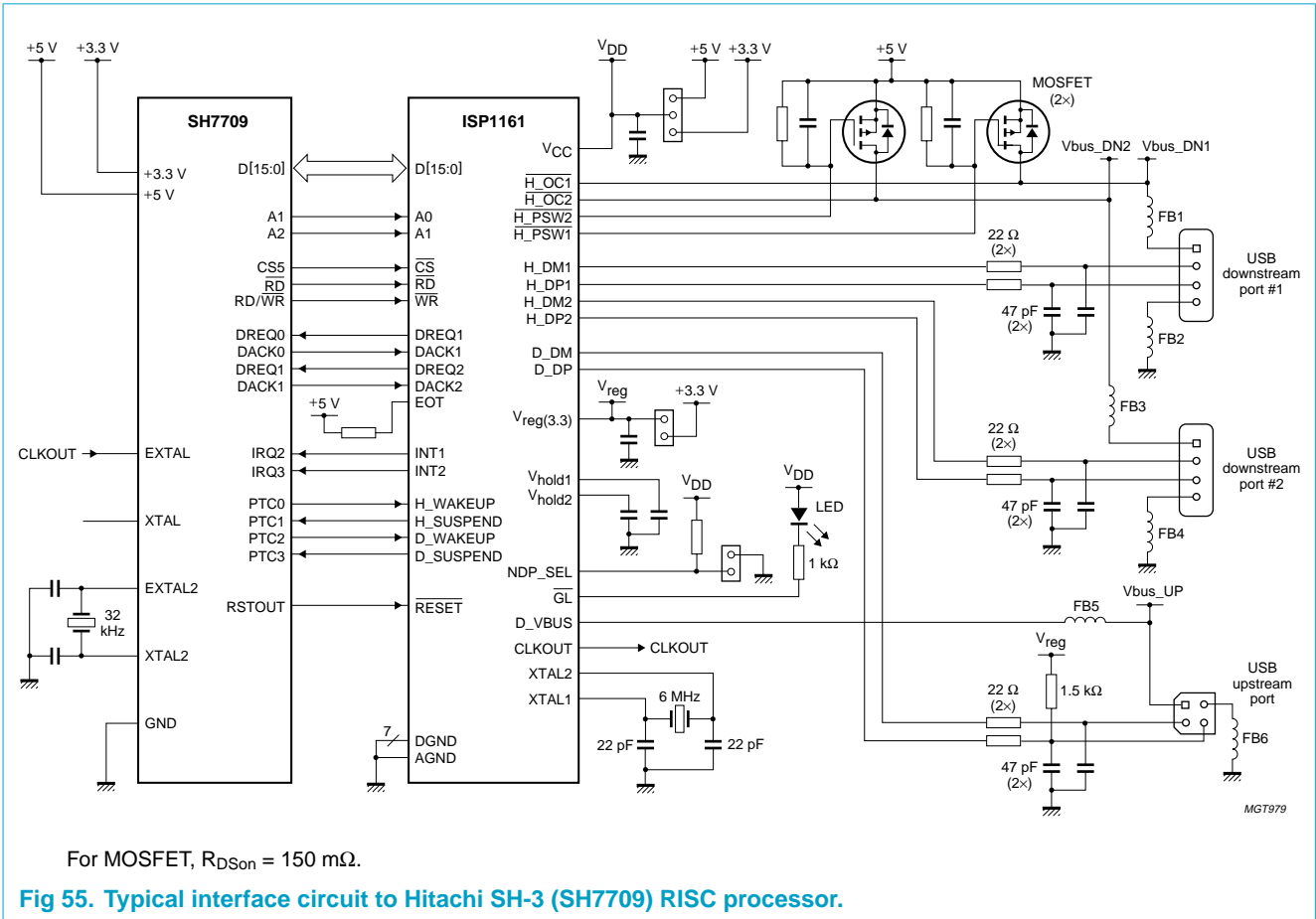

Fig 54. DMA terminated by EOT.

21. Application information

21.1 Typical interface circuit



21.2 Interfacing a ISP1161 with a SH7709 RISC processor

This section shows a typical interface circuit between ISP1161 and a RISC processor. The Hitachi SH-3 series RISC processor SH7709 is used as the example. The main ISP1161 signals to be taken into consideration for connecting to a SH7709 RISC processor are:

- A 16-bit data bus: D15-D0 for ISP1161. ISP1161 is 'little endian' compatible.
- Two address lines A1 and A0 are needed for a complete addressing of the ISP1161 internal registers:
 - A1 = 0 and A0 = 0 will select the Data Port of the Host Controller
 - A1 = 0 and A0 = 1 will select the Command Port of the Host Controller
 - A1 = 1 and A0 = 0 will select the Data Port of the Device Controller
 - A1 = 1 and A0 = 1 will select the Command Port of the Device Controller
- The \overline{CS} line is used for chip selection of ISP1161 in a certain address range of the RISC system. This signal is active LOW.
- \overline{RD} and \overline{WR} are common read and write signals. These signals are active LOW.
- There are two DMA channel standard control lines:
 - DREQ1 and DACK1
 - DREQ2 and DACK2
 (in each case one channel is used by the host controller and the other channel is used by the device controller). These signals have programmable active levels.
- Two interrupt lines: INT1 (used by the host controller) and INT2 (used by the device controller). Both have programmable level/edge and polarity (active HIGH or LOW).
- The internal 15k Ω pull-down resistors are used for the HCs two USB downstream ports.
- The \overline{RESET} signal is active LOW.

Remark: SH7709's system clock input is for reference only. Please refer to SH7709's specification for its actual use.

ISP1161 can work under either +3.3 V or +5.0 V power supply; however, its internal core actually works at +3.3 V. When using +5 V as the power supply input, the internal DC/DC regulator will be bypassed. It is best to connect all four power supply pins (V_{CC} , $V_{reg(3.3)}$, V_{hold1} and V_{hold2}) to the 3.3 V power supply (for more information see [Section 16](#)). All of the ISP1161's I/O pins are +5 V-tolerant. This feature allows the ISP1161 the flexibility to be used in an embedded system under either a +3.3 V or a +5 V power supply.

A typical SH7709 interface circuit is shown in [Figure 55](#).

21.3 Typical software model

This section shows a typical software requirement for an embedded system that incorporates ISP1161. The software model for a digital still camera (DSC) is used as the example for illustration (as shown in [Figure 56](#)). Two components of system software are required to make full use of the features in ISP1161: the host stack and

the device stack. The device stack provides API directly to the application task for device function; the host stack provides API for Class driver and device driver, both of which provide API for application tasks for host function.

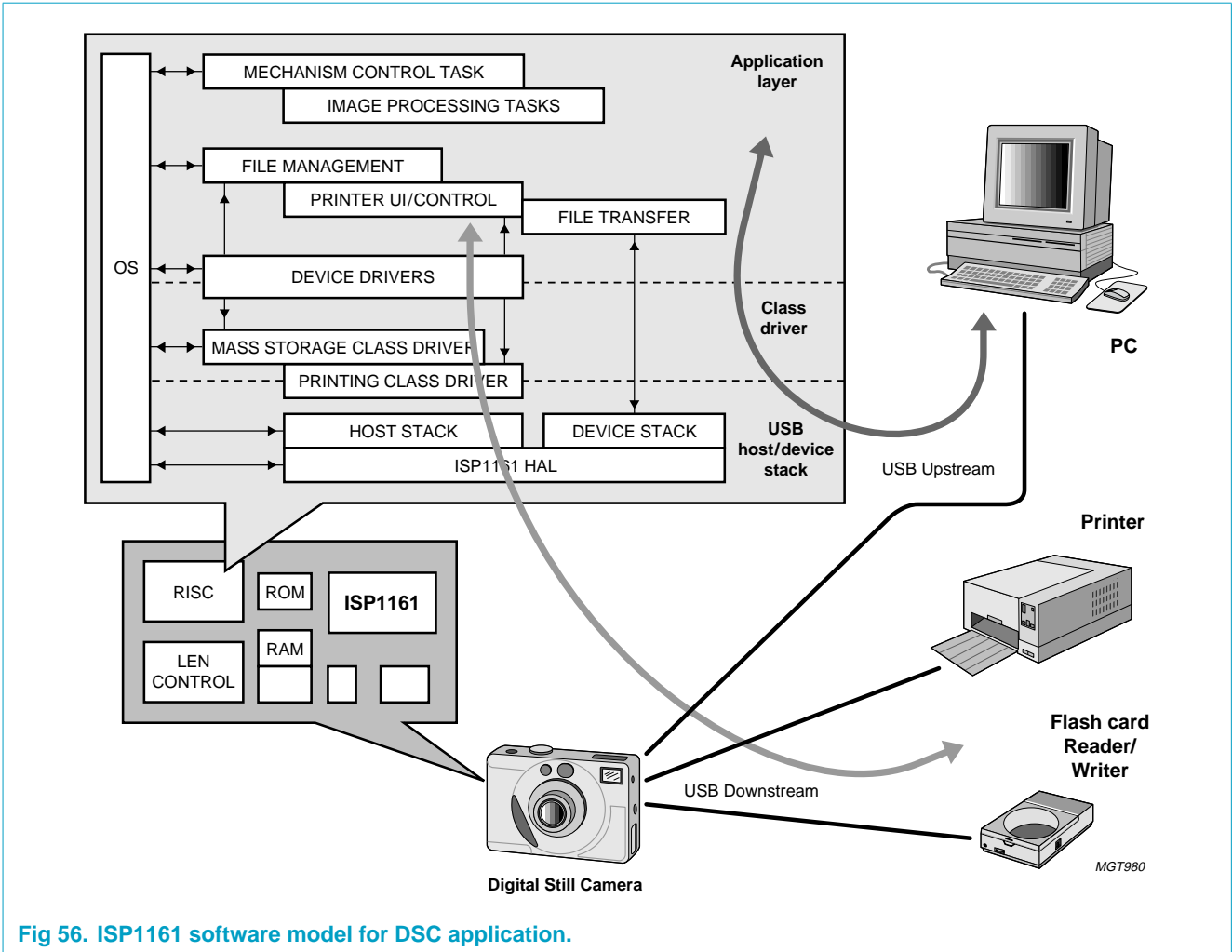
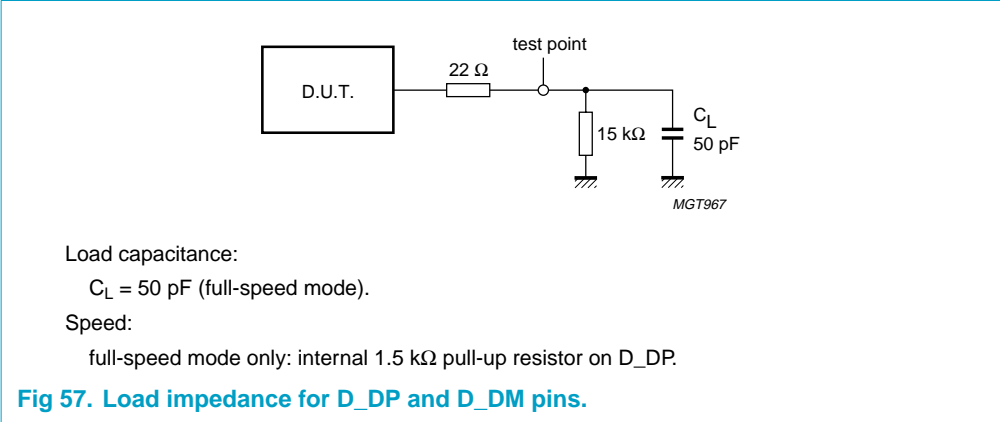

Fig 56. ISP1161 software model for DSC application.

22. Test information

The dynamic characteristics of the analog I/O ports (D+ and D-) as listed in Table 114 were determined using the circuit shown in Figure 57.



23. Package outline

LQFP64: plastic low profile quad flat package; 64 leads; body 10 x 10 x 1.4 mm

SOT314-2

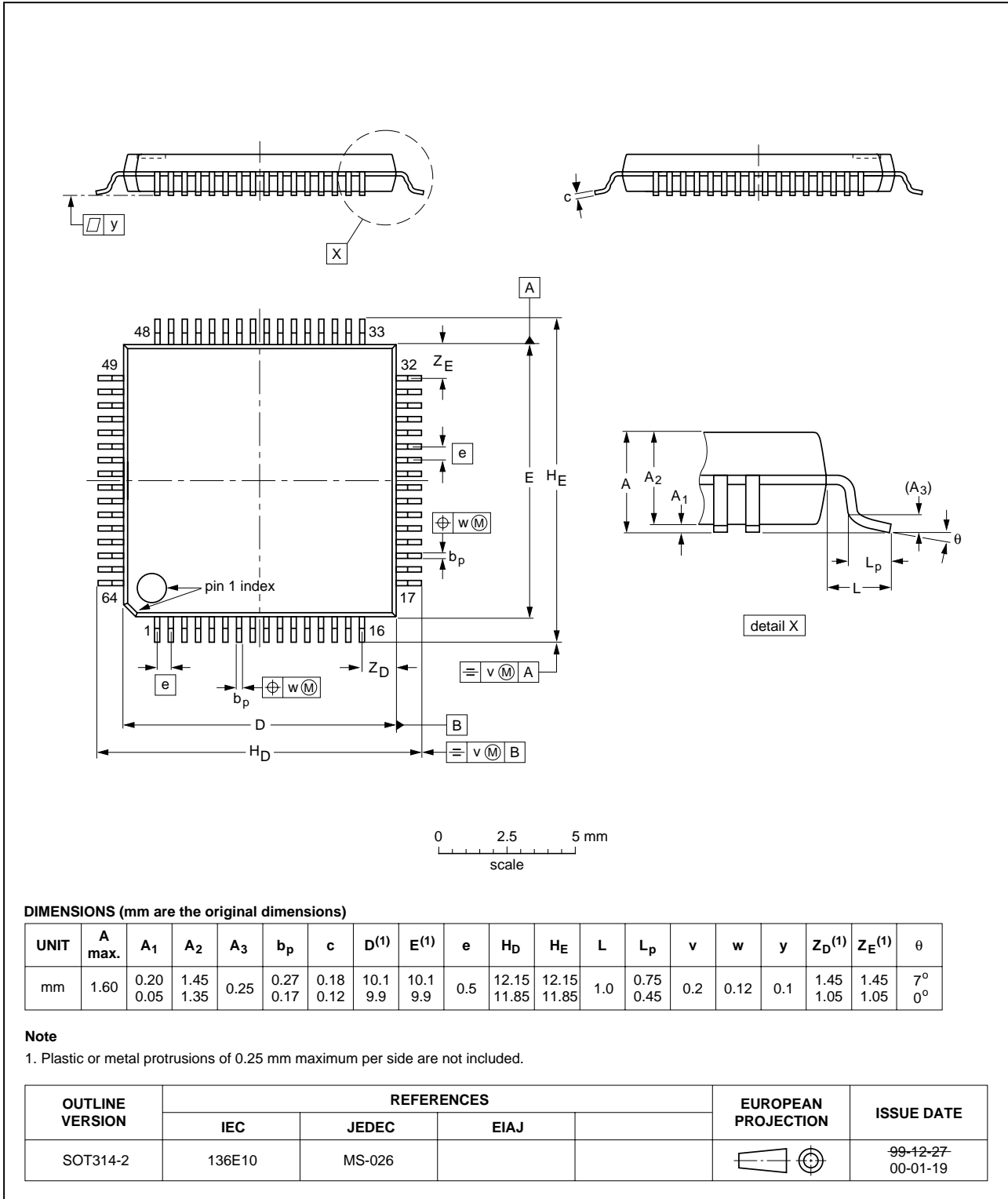

Fig 58. LQFP64 (SOT314-2) package outline.

LQFP64: plastic low profile quad flat package; 64 leads; body 7 x 7 x 1.4 mm

SOT414-1

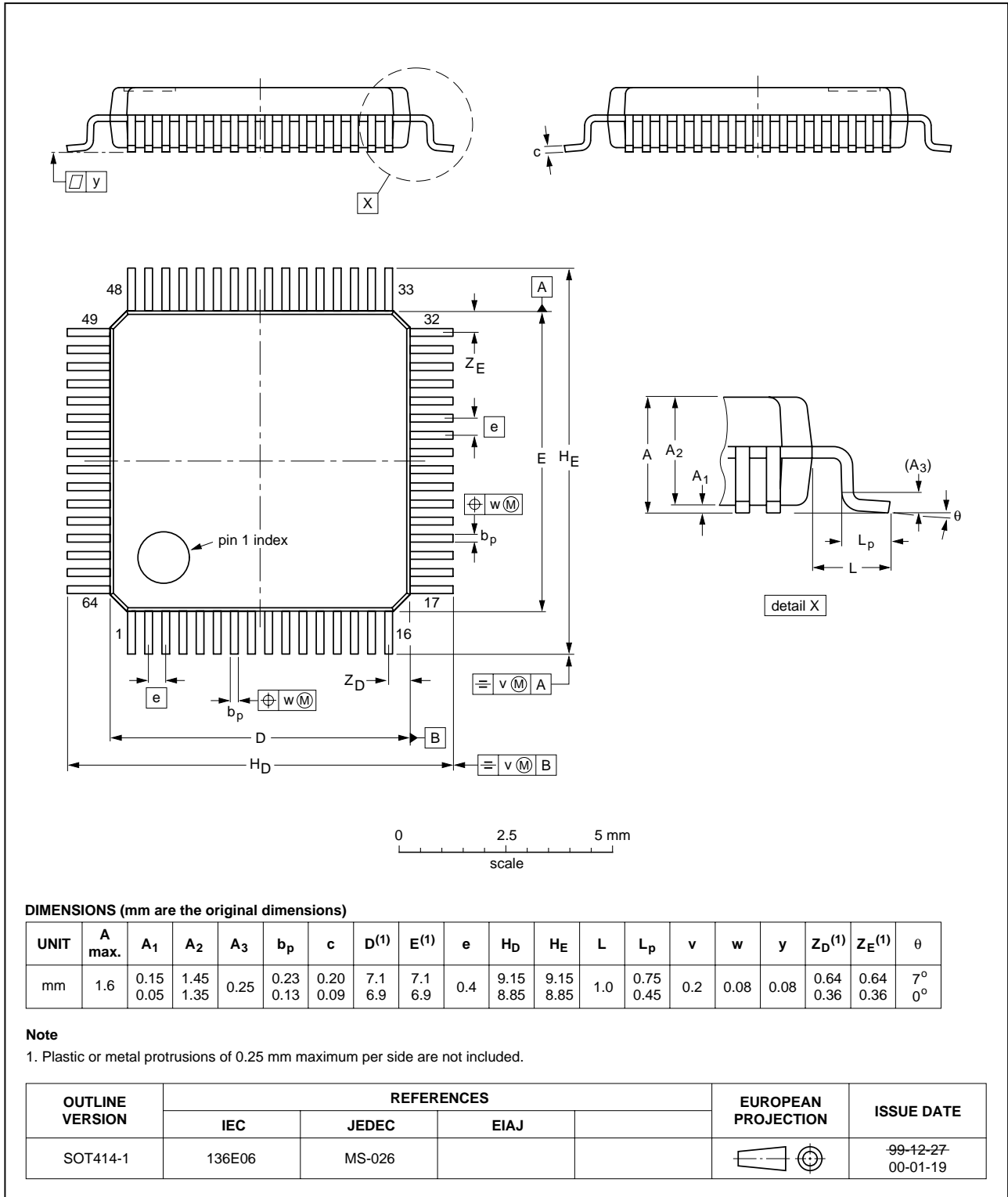

Fig 59. LQFP64 (SOT414-1) package outline.

24. Soldering

24.1 Introduction to soldering surface mount packages

This text gives a very brief insight to a complex technology. A more in-depth account of soldering ICs can be found in our *Data Handbook IC26; Integrated Circuit Packages* (document order number 9398 652 90011).

There is no soldering method that is ideal for all surface mount IC packages. Wave soldering can still be used for certain surface mount ICs, but it is not suitable for fine pitch SMDs. In these situations reflow soldering is recommended.

24.2 Reflow soldering

Reflow soldering requires solder paste (a suspension of fine solder particles, flux and binding agent) to be applied to the printed-circuit board by screen printing, stencilling or pressure-syringe dispensing before package placement.

Several methods exist for reflowing; for example, convection or convection/infrared heating in a conveyor type oven. Throughput times (preheating, soldering and cooling) vary between 100 and 200 seconds depending on heating method.

Typical reflow peak temperatures range from 215 to 250 °C. The top-surface temperature of the packages should preferably be kept below 220 °C for thick/large packages, and below 235 °C small/thin packages.

24.3 Wave soldering

Conventional single wave soldering is not recommended for surface mount devices (SMDs) or printed-circuit boards with a high component density, as solder bridging and non-wetting can present major problems.

To overcome these problems the double-wave soldering method was specifically developed.

If wave soldering is used the following conditions must be observed for optimal results:

- Use a double-wave soldering method comprising a turbulent wave with high upward pressure followed by a smooth laminar wave.
- For packages with leads on two sides and a pitch (e):
 - larger than or equal to 1.27 mm, the footprint longitudinal axis is **preferred** to be parallel to the transport direction of the printed-circuit board;
 - smaller than 1.27 mm, the footprint longitudinal axis **must** be parallel to the transport direction of the printed-circuit board.

The footprint must incorporate solder thieves at the downstream end.

- For packages with leads on four sides, the footprint must be placed at a 45° angle to the transport direction of the printed-circuit board. The footprint must incorporate solder thieves downstream and at the side corners.

During placement and before soldering, the package must be fixed with a droplet of adhesive. The adhesive can be applied by screen printing, pin transfer or syringe dispensing. The package can be soldered after the adhesive is cured.

Typical dwell time is 4 seconds at 250 °C. A mildly-activated flux will eliminate the need for removal of corrosive residues in most applications.

24.4 Manual soldering

Fix the component by first soldering two diagonally-opposite end leads. Use a low voltage (24 V or less) soldering iron applied to the flat part of the lead. Contact time must be limited to 10 seconds at up to 300 °C.

When using a dedicated tool, all other leads can be soldered in one operation within 2 to 5 seconds between 270 and 320 °C.

24.5 Package related soldering information

Table 124: Suitability of surface mount IC packages for wave and reflow soldering methods

Package	Soldering method	
	Wave	Reflow ^[1]
BGA, HBGA, LFBGA, SQFP, TFBGA	not suitable	suitable
HBCC, HLQFP, HSQFP, HSOP, HTQFP, HTSSOP, HVQFN, SMS	not suitable ^[2]	suitable
PLCC ^[3] , SO, SOJ	suitable	suitable
LQFP, QFP, TQFP	not recommended ^{[3][4]}	suitable
SSOP, TSSOP, VSO	not recommended ^[5]	suitable

- [1] All surface mount (SMD) packages are moisture sensitive. Depending upon the moisture content, the maximum temperature (with respect to time) and body size of the package, there is a risk that internal or external package cracks may occur due to vaporization of the moisture in them (the so called popcorn effect). For details, refer to the Drypack information in the *Data Handbook IC26; Integrated Circuit Packages; Section: Packing Methods*.
- [2] These packages are not suitable for wave soldering as a solder joint between the printed-circuit board and heatsink (at bottom version) can not be achieved, and as solder may stick to the heatsink (on top version).
- [3] If wave soldering is considered, then the package must be placed at a 45° angle to the solder wave direction. The package footprint must incorporate solder thieves downstream and at the side corners.
- [4] Wave soldering is only suitable for LQFP, QFP and TQFP packages with a pitch (e) equal to or larger than 0.8 mm; it is definitely not suitable for packages with a pitch (e) equal to or smaller than 0.65 mm.
- [5] Wave soldering is only suitable for SSOP and TSSOP packages with a pitch (e) equal to or larger than 0.65 mm; it is definitely not suitable for packages with a pitch (e) equal to or smaller than 0.5 mm.

25. Revision history

Table 125: Revision history

Rev	Date	CPCN	Description
01	20010703	-	Product data; initial version.

26. Data sheet status

Data sheet status ^[1]	Product status ^[2]	Definition
Objective data	Development	This data sheet contains data from the objective specification for product development. Philips Semiconductors reserves the right to change the specification in any manner without notice.
Preliminary data	Qualification	This data sheet contains data from the preliminary specification. Supplementary data will be published at a later date. Philips Semiconductors reserves the right to change the specification without notice, in order to improve the design and supply the best possible product.
Product data	Production	This data sheet contains data from the product specification. Philips Semiconductors reserves the right to make changes at any time in order to improve the design, manufacturing and supply. Changes will be communicated according to the Customer Product/Process Change Notification (CPCN) procedure SNW-SQ-650A.

[1] Please consult the most recently issued data sheet before initiating or completing a design.

[2] The product status of the device(s) described in this data sheet may have changed since this data sheet was published. The latest information is available on the Internet at URL <http://www.semiconductors.philips.com>.

27. Definitions

Short-form specification — The data in a short-form specification is extracted from a full data sheet with the same type number and title. For detailed information see the relevant data sheet or data handbook.

Limiting values definition — Limiting values given are in accordance with the Absolute Maximum Rating System (IEC 60134). Stress above one or more of the limiting values may cause permanent damage to the device. These are stress ratings only and operation of the device at these or at any other conditions above those given in the Characteristics sections of the specification is not implied. Exposure to limiting values for extended periods may affect device reliability.

Application information — Applications that are described herein for any of these products are for illustrative purposes only. Philips Semiconductors make no representation or warranty that such applications will be suitable for the specified use without further testing or modification.

28. Disclaimers

Life support — These products are not designed for use in life support appliances, devices, or systems where malfunction of these products can reasonably be expected to result in personal injury. Philips Semiconductors customers using or selling these products for use in such applications do so at their own risk and agree to fully indemnify Philips Semiconductors for any damages resulting from such application.

Right to make changes — Philips Semiconductors reserves the right to make changes, without notice, in the products, including circuits, standard cells, and/or software, described or contained herein in order to improve design and/or performance. Philips Semiconductors assumes no responsibility or liability for the use of any of these products, conveys no licence or title under any patent, copyright, or mask work right to these products, and makes no representations or warranties that these products are free from patent, copyright, or mask work right infringement, unless otherwise specified.

29. Trademarks

GoodLink — is a trademark of Koninklijke Philips Electronics N.V.

Hitachi — is a registered trademark of Hitachi Ltd.

SoftConnect — is a trademark of Koninklijke Philips Electronics N.V.

ARM — is a trademark of ARM Holdings PLC.

StrongARM — is a trademark of ARM Holdings PLC.

Philips Semiconductors - a worldwide company

Argentina: see South America

Australia: Tel. +61 2 9704 8141, Fax. +61 2 9704 8139

Austria: Tel. +43 160 101, Fax. +43 160 101 1210

Belarus: Tel. +375 17 220 0733, Fax. +375 17 220 0773

Belgium: see The Netherlands

Brazil: see South America

Bulgaria: Tel. +359 268 9211, Fax. +359 268 9102

Canada: Tel. +1 800 234 7381

China/Hong Kong: Tel. +852 2 319 7888, Fax. +852 2 319 7700

Colombia: see South America

Czech Republic: see Austria

Denmark: Tel. +45 3 288 2636, Fax. +45 3 157 0044

Finland: Tel. +358 961 5800, Fax. +358 96 158 0920

France: Tel. +33 1 4728 6600, Fax. +33 1 4728 6638

Germany: Tel. +49 40 23 5360, Fax. +49 402 353 6300

Hungary: Tel. +36 1 382 1700, Fax. +36 1 382 1800

India: Tel. +91 22 493 8541, Fax. +91 22 493 8722

Indonesia: see Singapore

Ireland: Tel. +353 17 64 0000, Fax. +353 17 64 0200

Israel: Tel. +972 36 45 0444, Fax. +972 36 49 1007

Italy: Tel. +39 039 203 6838, Fax. +39 039 203 6800

Japan: Tel. +81 33 740 5130, Fax. +81 3 3740 5057

Korea: Tel. +82 27 09 1412, Fax. +82 27 09 1415

Malaysia: Tel. +60 37 50 5214, Fax. +60 37 57 4880

Mexico: Tel. +9-5 800 234 7381

Middle East: see Italy

For all other countries apply to: Philips Semiconductors,
Marketing Communications,
Building BE, P.O. Box 218, 5600 MD EINDHOVEN,
The Netherlands, Fax. +31 40 272 4825

Netherlands: Tel. +31 40 278 2785, Fax. +31 40 278 8399

New Zealand: Tel. +64 98 49 4160, Fax. +64 98 49 7811

Norway: Tel. +47 22 74 8000, Fax. +47 22 74 8341

Philippines: Tel. +63 28 16 6380, Fax. +63 28 17 3474

Poland: Tel. +48 22 5710 000, Fax. +48 22 5710 001

Portugal: see Spain

Romania: see Italy

Russia: Tel. +7 095 755 6918, Fax. +7 095 755 6919

Singapore: Tel. +65 350 2538, Fax. +65 251 6500

Slovakia: see Austria

Slovenia: see Italy

South Africa: Tel. +27 11 471 5401, Fax. +27 11 471 5398

South America: Tel. +55 11 821 2333, Fax. +55 11 829 1849

Spain: Tel. +34 33 01 6312, Fax. +34 33 01 4107

Sweden: Tel. +46 86 32 2000, Fax. +46 86 32 2745

Switzerland: Tel. +41 14 88 2686, Fax. +41 14 81 7730

Taiwan: Tel. +886 22 134 2451, Fax. +886 22 134 2874

Thailand: Tel. +66 23 61 7910, Fax. +66 23 98 3447

Turkey: Tel. +90 216 522 1500, Fax. +90 216 522 1813

Ukraine: Tel. +380 44 264 2776, Fax. +380 44 268 0461

United Kingdom: Tel. +44 208 730 5000, Fax. +44 208 754 8421

United States: Tel. +1 800 234 7381

Uruguay: see South America

Vietnam: see Singapore

Yugoslavia: Tel. +381 11 3341 299, Fax. +381 11 3342 553

Internet: <http://www.semiconductors.philips.com>

(SCA72)

Contents

1	General description	1	12.4	End-Of-Transfer conditions	51
2	Features	3	13	HC registers	53
3	Applications	4	13.1	HC control and status registers	54
4	Ordering information	4	13.2	HC frame counter registers	62
5	Block diagram	5	13.3	HC Root Hub registers	66
6	Pinning information	7	13.4	HC DMA and interrupt control registers	76
6.1	Pinning	7	13.5	HC miscellaneous registers	81
6.2	Pin description	7	13.6	HC buffer RAM control registers	82
7	Functional description	11	14	DC commands and registers	86
7.1	PLL clock multiplier	11	14.1	Initialization commands	89
7.2	Bit clock recovery	11	14.2	Data flow commands	96
7.3	Analog transceivers	11	14.3	General commands	100
7.4	Philips Serial Interface Engine (SIE)	11	15	Reset	105
7.5	SoftConnect (in DC)	11	16	Power supply	105
7.6	GoodLink (in DC)	12	17	External clock input	106
7.7	Suspend and wakeup (in DC)	12	18	Limiting values	107
8	Microprocessor bus interface	12	19	Static characteristics	108
8.1	I/O addressing mode	12	20	Dynamic characteristics	111
8.2	DMA mode	13	20.1	Timing symbols	112
8.3	Microprocessor read/write ISP1161's internal control registers by PIO mode	14	20.2	Parallel I/O timing	113
8.4	Microprocessor read/write ISP1161's internal FIFO buffer RAM by PIO mode	17	20.3	DMA interface timing	114
8.5	Microprocessor read/write ISP1161's internal FIFO buffer RAM by DMA mode	17	21	Application information	119
8.6	Interrupts	19	21.1	Typical interface circuit	119
9	The USB host controller (HC)	22	21.2	Interfacing a ISP1161 with a SH7709 RISC processor	120
9.1	The HC's four USB states	22	21.3	Typical software model	120
9.2	Generating USB traffic	22	22	Test information	121
9.3	PTD data structure	24	23	Package outline	123
9.4	HC's internal FIFO buffer RAM structure	27	24	Soldering	125
9.5	HC's operational model	33	24.1	Introduction to soldering surface mount packages	125
9.6	Microprocessor loading	36	24.2	Reflow soldering	125
9.7	Internal 15 kW pull-down resistors for downstream ports	36	24.3	Wave soldering	125
9.8	Overcurrent detection and power switching control	37	24.4	Manual soldering	126
10	Suspend and wakeup (in HC)	40	24.5	Package related soldering information	126
10.1	HC suspended state	40	25	Revision history	126
10.2	HC wakeup from suspended state	41	26	Data sheet status	127
11	The USB device controller (DC)	42	27	Definitions	127
11.1	DC data transfer operation	42	28	Disclaimers	127
11.2	Device DMA transfer	43	29	Trademarks	127
11.3	Endpoint descriptions	44			
12	DMA transfer for the Device Controller	48			
12.1	Selecting an endpoint for DMA transfer	48			
12.2	8237 compatible mode	49			
12.3	DACK-only mode	50			

PHILIPS
Let's make things better.



LittleDiode supplies new, hard to find or obsolete electronic components and semiconductors all over the world.

With over two million different components listed you are sure to find the part you need.

Feel free to visit us today at our online store:

LittleDiode.com

Looking forward to providing you with the best possible service.