



# ISP1582

Hi-Speed Universal Serial Bus peripheral controller

Rev. 03 — 25 August 2004

Preliminary data

## 1. General description

---

The ISP1582 is a cost-optimized and feature-optimized Hi-Speed Universal Serial Bus (USB) peripheral controller. It fully complies with *Universal Serial Bus Specification Rev. 2.0*, supporting data transfer at high-speed (480 Mbit/s) and full-speed (12 Mbit/s).

The ISP1582 provides high-speed USB communication capacity to systems based on microcontrollers or microprocessors. It communicates with a microcontroller or microprocessor of a system through a high-speed general-purpose parallel interface.

The ISP1582 supports automatic detection of Hi-Speed USB system operation. Original USB fall-back mode allows the device to remain operational under full-speed conditions. It is designed as a generic USB peripheral controller so that it can fit into all existing device classes, such as imaging class, mass storage devices, communication devices, printing devices and human interface devices.

The internal generic Direct Memory Access (DMA) block allows easy integration into data streaming applications.

The modular approach to implementing a USB peripheral controller allows the designer to select the optimum system microcontroller from the wide variety available. The ability to reuse existing architecture and firmware investments shortens the development time, eliminates risk and reduces cost. The result is fast and efficient development of the most cost-effective USB peripheral solution.

The ISP1582 is ideally suited for many types of peripherals, such as: printers, scanners, digital still cameras, USB-to-Ethernet links, cable and DSL modems. The low power consumption during suspend mode allows easy design of equipment that is compliant to the ACPI™, OnNow™ and USB power management requirements.

The ISP1582 also incorporates features such as SoftConnect™, a reduced frequency crystal oscillator, and integrated termination resistors. These features allow significant cost savings in system design and easy implementation of advanced USB functionality into PC peripherals.



**PHILIPS**

## 2. Features

- Complies fully with:
  - ◆ *Universal Serial Bus Specification Rev. 2.0*
  - ◆ Most Device Class specifications
  - ◆ ACPI™, OnNow™ and USB power management requirements.
- Supports data transfer at high-speed (480 Mbit/s) and full-speed (12 Mbit/s)
- High performance USB peripheral controller with integrated Serial Interface Engine (SIE), Parallel Interface Engine (PIE), FIFO memory and data transceiver
- Automatic Hi-Speed USB mode detection and Original USB fall-back mode
- Supports sharing mode
- Supports  $V_{BUS}$  sensing
- High-speed DMA interface
- Fully autonomous and multiconfiguration DMA operation
- 7 IN endpoints, 7 OUT endpoints and a fixed control IN/OUT endpoint
- Integrated physical 8 kbytes of multiconfiguration FIFO memory
- Endpoints with double buffering to increase throughput and ease real-time data transfer
- Bus-independent interface with most microcontrollers and microprocessors
- 12 MHz crystal oscillator with integrated PLL for low EMI
- Software-controlled connection to the USB bus (SoftConnect™)
- Low-power consumption in operation and power-down modes; suitable for use in bus-powered USB devices
- Supports Session Request Protocol (SRP) that complies with *On-The-Go Supplement to the USB Specification Rev. 1.0a*
- Internal power-on and low-voltage reset circuits; also supports software reset
- Operation over the extended USB bus voltage range (DP, DM and  $V_{BUS}$ )
- 5 V tolerant I/O pads at 3.3 V
- Operating temperature range from  $-40\text{ }^{\circ}\text{C}$  to  $+85\text{ }^{\circ}\text{C}$
- Available in HVQFN56 halogen-free and lead-free package.

## 3. Applications

- Personal digital assistant
- Digital video camera
- Digital still camera
- 3G mobile phone
- MP3 player
- Communication device, for example: router and modem
- Printer
- Scanner.

## 4. Abbreviations

<b>DMA</b>	— Direct Memory Access
<b>EMI</b>	— ElectroMagnetic Interference
<b>FS</b>	— Full-speed
<b>GDMA</b>	— Generic DMA
<b>HS</b>	— High-speed
<b>MMU</b>	— Memory Management Unit
<b>NRZI</b>	— Non-Return-to-Zero Inverted
<b>OTG</b>	— On-The-Go
<b>PDA</b>	— Personal Digital Assistant
<b>PID</b>	— Packet IDentifier
<b>PIE</b>	— Parallel Interface Engine
<b>PIO</b>	— Parallel Input/Output
<b>PLL</b>	— Phase-Locked Loop
<b>SE0</b>	— Single-Ended zero
<b>SIE</b>	— Serial Interface Engine
<b>SRP</b>	— Session Request Protocol
<b>USB</b>	— Universal Serial Bus.

## 5. Ordering information

**Table 1: Ordering information**

Type number	Package		
	Name	Description	Version
ISP1582BS	HVQFN56	plastic thermal enhanced very thin quad flat package; no leads; 56 terminals; body 8 × 8 × 0.85 mm	SOT684-1



## 7. Pinning information

### 7.1 Pinning

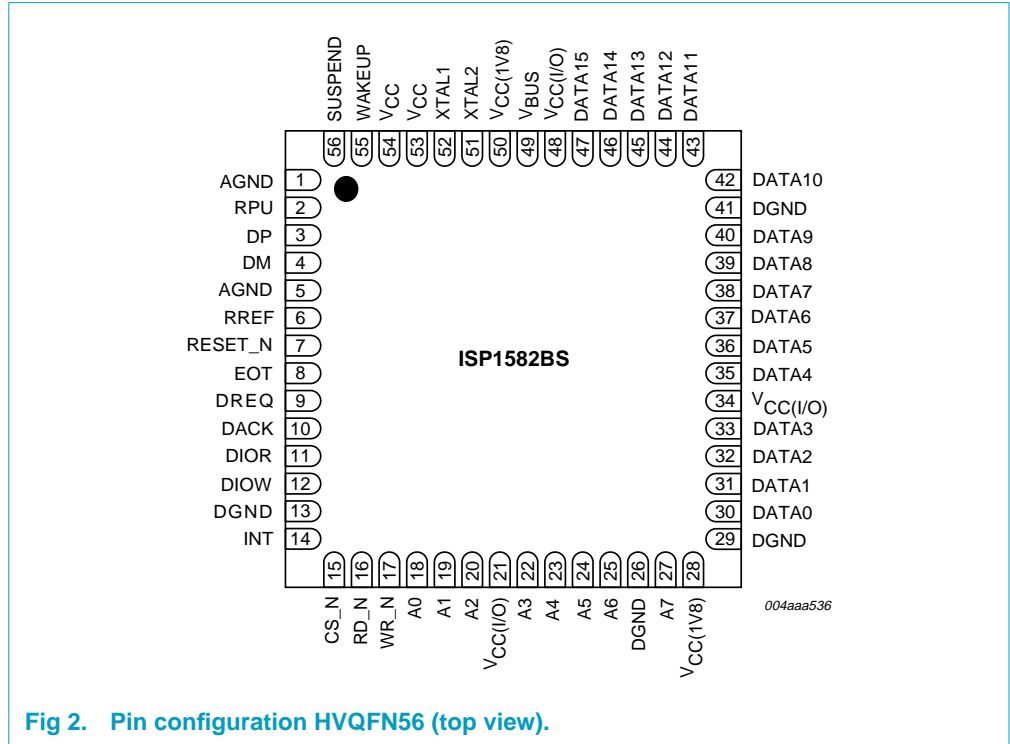

Fig 2. Pin configuration HVQFN56 (top view).

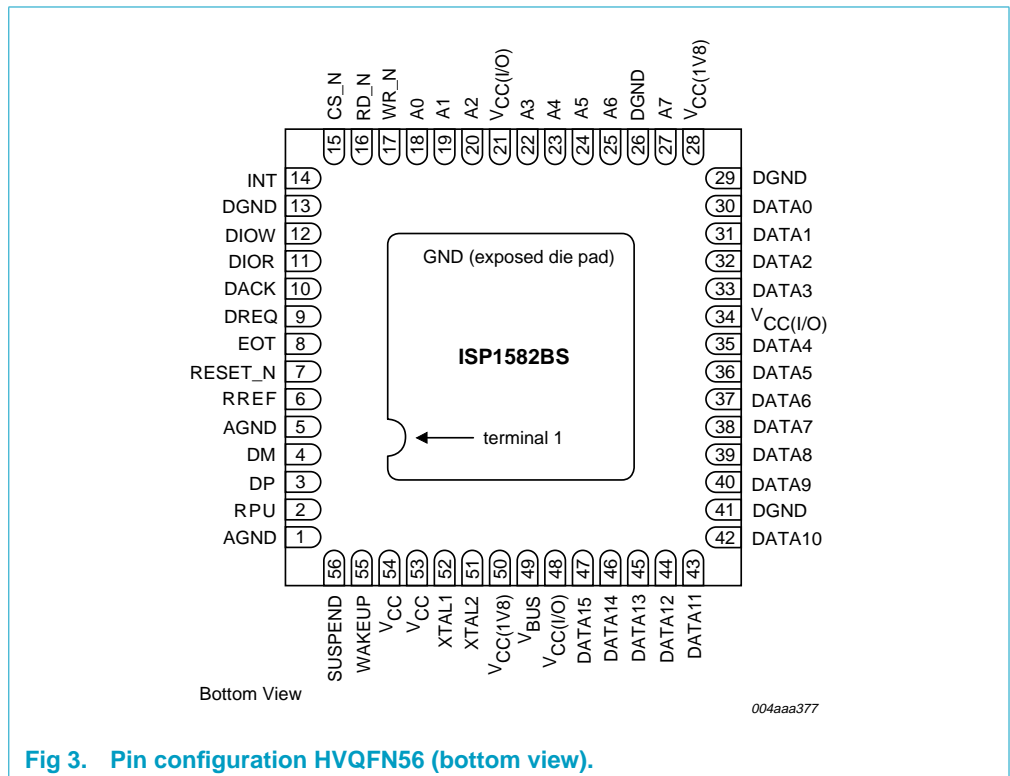

Fig 3. Pin configuration HVQFN56 (bottom view).

## 7.2 Pin description

Table 2: Pin description

Symbol <sup>[1]</sup>	Pin	Type <sup>[2]</sup>	Description
AGND	1	-	analog ground
RPU	2	A	connect to the external pull-up resistor for pin DP; must be connected to 3.3 V via a 1.5 kΩ resistor
DP	3	A	USB D+ line connection (analog)
DM	4	A	USB D- line connection (analog)
AGND	5	-	analog ground
RREF	6	A	connect to the external bias resistor; must be connected to ground via a 12.0 kΩ ± 1 % resistor
RESET_N	7	I	reset input (500 μs); a LOW level produces an asynchronous reset; connect to V <sub>CC</sub> for the power-on reset (internal POR circuit) TTL; 5 V tolerant
EOT	8	I	End-of-transfer input (programmable polarity); used in DMA slave mode only; when not in use, connect this pin to V <sub>CC(I/O)</sub> through a 10 kΩ resistor input pad; TTL; 5 V tolerant
DREQ	9	O	DMA request (programmable polarity) output; when not in use, connect this pin to ground through a 10 kΩ resistor; see <a href="#">Table 54</a> and <a href="#">Table 55</a> TTL; 4 ns slew-rate control
DACK	10	I	DMA acknowledge input (programmable polarity); when not in use, connect this pin to V <sub>CC(I/O)</sub> through a 10 kΩ resistor; see <a href="#">Table 54</a> and <a href="#">Table 55</a> TTL; 5 V tolerant
DIOR	11	I	DMA read strobe input (programmable polarity); when not in use, connect this pin to V <sub>CC(I/O)</sub> through a 10 kΩ resistor; see <a href="#">Table 54</a> and <a href="#">Table 55</a> TTL; 5 V tolerant
DIOW	12	I	DMA write strobe input (programmable polarity); when not in use, connect this pin to V <sub>CC(I/O)</sub> through a 10 kΩ resistor; see <a href="#">Table 54</a> and <a href="#">Table 55</a> TTL; 5 V tolerant
DGND	13	-	digital ground
INT	14	O	interrupt output; programmable polarity (active HIGH or LOW) and signaling (edge or level triggered) CMOS output; 8 mA drive
CS_N	15	I	chip select input input pad; TTL; 5 V tolerant
RD_N	16	I	read strobe input input pad; TTL; 5 V tolerant
WR_N	17	I	write strobe input input pad; TTL; 5 V tolerant

Table 2: Pin description...continued

Symbol <sup>[1]</sup>	Pin	Type <sup>[2]</sup>	Description
A0	18	I	bit 0 of the address bus input pad; TTL; 5 V tolerant
A1	19	I	bit 1 of the address bus input pad; TTL; 5 V tolerant
A2	20	I	bit 2 of the address bus input pad; TTL; 5 V tolerant
V <sub>CC(I/O)</sub> <sup>[3]</sup>	21	-	supply voltage; used to supply voltage to the I/O pads; see <a href="#">Section 8.14</a>
A3	22	I	bit 3 of the address bus input pad; TTL; 5 V tolerant
A4	23	I	bit 4 of the address bus input pad; TTL; 5 V tolerant
A5	24	I	bit 5 of the address bus input pad; TTL; 5 V tolerant
A6	25	I	bit 6 of the address bus input pad; TTL; 5 V tolerant
DGND	26	-	digital ground
A7	27	I	bit 7 of the address bus input pad; TTL; 5 V tolerant
V <sub>CC(1V8)</sub> <sup>[3]</sup>	28	-	regulator output voltage (1.8 V ± 0.15 V); tapped out voltage from the internal regulator; this regulated voltage cannot drive external devices; decouple this pin using a 0.1 µF capacitor; see <a href="#">Section 8.14</a>
DGND	29	-	digital ground
DATA0	30	I/O	bit 0 of bidirectional data bus bidirectional pad; 4 ns slew-rate control; TTL; 5 V tolerant
DATA1	31	I/O	bit 1 of bidirectional data bus bidirectional pad; 4 ns slew-rate control; TTL; 5 V tolerant
DATA2	32	I/O	bit 2 of bidirectional data bus bidirectional pad; 4 ns slew-rate control; TTL; 5 V tolerant
DATA3	33	I/O	bit 3 of bidirectional data bus bidirectional pad; 4 ns slew-rate control; TTL; 5 V tolerant
V <sub>CC(I/O)</sub> <sup>[3]</sup>	34	-	supply voltage; used to supply voltage to the I/O pads; see <a href="#">Section 8.14</a>
DATA4	35	I/O	bit 4 of bidirectional data bus bidirectional pad; 4 ns slew-rate control; TTL; 5 V tolerant
DATA5	36	I/O	bit 5 of bidirectional data bus bidirectional pad; 4 ns slew-rate control; TTL; 5 V tolerant
DATA6	37	I/O	bit 6 of bidirectional data bus bidirectional pad; 4 ns slew-rate control; TTL; 5 V tolerant
DATA7	38	I/O	bit 7 of bidirectional data bus bidirectional pad; 4 ns slew-rate control; TTL; 5 V tolerant

Table 2: Pin description...continued

Symbol <sup>[1]</sup>	Pin	Type <sup>[2]</sup>	Description
DATA8	39	I/O	bit 8 of bidirectional data bus bidirectional pad; 4 ns slew-rate control; TTL; 5 V tolerant
DATA9	40	I/O	bit 9 of bidirectional data bus bidirectional pad; 4 ns slew-rate control; TTL; 5 V tolerant
DGND	41	-	digital ground
DATA10	42	I/O	bit 10 of bidirectional data bus bidirectional pad; 4 ns slew-rate control; TTL; 5 V tolerant
DATA11	43	I/O	bit 11 of bidirectional data bus bidirectional pad; 4 ns slew-rate control; TTL; 5 V tolerant
DATA12	44	I/O	bit 12 of bidirectional data bus bidirectional pad; 4 ns slew-rate control; TTL; 5 V tolerant
DATA13	45	I/O	bit 13 of bidirectional data bus bidirectional pad; 4 ns slew-rate control; TTL; 5 V tolerant
DATA14	46	I/O	bit 14 of bidirectional data bus bidirectional pad; 4 ns slew-rate control; TTL; 5 V tolerant
DATA15	47	I/O	bit 15 of bidirectional data bus bidirectional pad; 4 ns slew-rate control; TTL; 5 V tolerant
V <sub>CC(I/O)</sub> <sup>[3]</sup>	48	-	supply voltage; used to supply voltage to the I/O pads; see <a href="#">Section 8.14</a>
V <sub>BUS</sub>	49	A	USB bus power pin sensing input; used to detect whether the host is connected or not; it is an output for V <sub>BUS</sub> pulsing in OTG mode; when V <sub>BUS</sub> is not detected, pin RPU is internally disconnected from pin DP in approximately 4 ns; connect a 1 μF electrolytic capacitor and a 1 MΩ pull-down resistor to ground; see <a href="#">Section 8.12</a> 5 V tolerant
V <sub>CC(1V8)</sub> <sup>[3]</sup>	50	-	regulator output voltage (1.8 V ± 0.15 V); tapped out voltage from the internal regulator; this regulated voltage can drive external devices up to 1 mA; decouple this pin using 4.7 μF and 0.1 μF capacitors; see <a href="#">Section 8.14</a>
XTAL2	51	O	crystal oscillator output (12 MHz); connect a fundamental parallel-resonant crystal; leave this pin open-circuit when using an external clock source on pin XTAL1; see <a href="#">Table 83</a>
XTAL1	52	I	crystal oscillator input (12 MHz); connect a fundamental parallel-resonant crystal or an external clock source (leaving pin XTAL2 unconnected); see <a href="#">Table 83</a>
V <sub>CC</sub> <sup>[3]</sup>	53	-	supply voltage (3.3 V ± 0.3 V); this pin supplies the internal voltage regulator and the analog circuit; see <a href="#">Section 8.14</a>
V <sub>CC</sub> <sup>[3]</sup>	54	-	supply voltage (3.3 V ± 0.3 V); this pin supplies the internal voltage regulator and the analog circuit; see <a href="#">Section 8.14</a>

Table 2: Pin description...continued

Symbol <sup>[1]</sup>	Pin	Type <sup>[2]</sup>	Description
WAKEUP	55	I	wake-up input; when this pin is at the HIGH level, the chip is prevented from getting into the suspend state and the chip wakes up from the suspend state; when not in use, connect this pin to ground through a 10 kΩ resistor input pad; TTL; 5 V tolerant
SUSPEND	56	O	suspend state indicator output; used as a power switch control output for powered-off application or as a resume signal to the CPU for powered-on application CMOS output; 8 mA drive
GND	exposed die pad	-	ground supply; down bonded to the exposed die pad (heatsink); to be connected to DGND during PCB layout

[1] Symbol names ending with underscore N (for example, NAME\_N) represent active LOW signals.

[2] All outputs and I/O pins can source 4 mA.

[3] Add a decoupling capacitor (0.1 μF) to all the supply pins. For better EMI results, add a 0.01 μF capacitor in parallel to the 0.1 μF.

## 8. Functional description

The ISP1582 is a high-speed USB peripheral controller. It implements the Hi-Speed USB or the Original USB physical layer and the packet protocol layer. It maintains up to 16 USB endpoints concurrently (control IN and control OUT, 7 IN and 7 OUT configurable) along with endpoint EP0 setup, which accesses the setup buffer. The USB Chapter 9 protocol handling is executed by means of external firmware.

For high-bandwidth data transfer, the integrated DMA handler can be invoked to transfer data to or from external memory or devices. The DMA interface can be configured by writing to the proper DMA registers (see [Section 9.4](#)).

The ISP1582 supports Hi-Speed USB and Original USB signaling. The USB signaling speed is automatically detected.

The ISP1582 has 8 kbytes of internal FIFO memory, which is shared among the enabled USB endpoints.

There are 7 IN endpoints, 7 OUT endpoints and 2 control endpoints that are a fixed 64 bytes long. Any of the 7 IN and 7 OUT endpoints can be separately enabled or disabled. The endpoint type (interrupt, isochronous or bulk) and packet size of these endpoints can be individually configured depending on the requirements of the application. Optional double buffering increases the data throughput of these data endpoints.

The ISP1582 requires 3.3 V power supply. It has 5 V tolerant I/O pads when operating at  $V_{CC(I/O)} = 3.3$  V and an internal 1.8 V regulator for powering the analog transceiver.

The ISP1582 operates on a 12 MHz crystal oscillator. An integrated  $40 \times$  PLL clock multiplier generates the internal sampling clock of 480 MHz.

### 8.1 DMA interface, DMA handler and DMA registers

The DMA block can be subdivided into two blocks: the DMA handler and the DMA interface.

The firmware writes to the DMA command register to start a DMA transfer (see [Table 47](#)). The command opcode determines whether a generic DMA or PIO transfer will start. The handler interfaces to the same FIFO (internal RAM) as used by the USB core. On receiving the DMA command, the DMA handler directs the data from the endpoint FIFO to the external DMA device or from the external DMA device to the endpoint FIFO.

The DMA interface configures the timing and the DMA handshake. Data can be transferred using either the DIOR and DIOV strobes or by the DACK and DREQ handshakes. The DMA configurations are set up by writing to the DMA Configuration register (see [Table 52](#) and [Table 53](#)).

For a generic DMA interface, Generic DMA (GDMA) slave mode can be used.

**Remark:** The DMA endpoint buffer length must be a multiple of 4 bytes.

For details on DMA registers, see [Section 9.4](#).

## 8.2 Hi-Speed USB transceiver

The analog transceiver directly interfaces to the USB cable through integrated termination resistors. The high-speed transceiver requires an external resistor ( $12.0\text{ k}\Omega \pm 1\%$ ) between pin RREF and ground to ensure an accurate current mirror that generates the Hi-Speed USB current drive. A full-speed transceiver is integrated as well. This makes the ISP1582 compliant to Hi-Speed USB and Original USB, supporting both the high-speed and full-speed physical layers. After automatic speed detection, the Philips Serial Interface Engine (SIE) sets the transceiver to use either high-speed or full-speed signaling.

## 8.3 MMU and integrated RAM

The Memory Management Unit (MMU) and the integrated RAM provide the conversion between the USB speed (full-speed: 12 Mbit/s, high-speed: 480 Mbit/s) and the microcontroller handler or the DMA handler. The data from the USB bus is stored in the integrated RAM, which is cleared only when the microcontroller has read or written all data from or to the corresponding endpoint buffer or when the DMA handler has read or written all data from or to the endpoint buffer. The OUT endpoint buffer can also be cleared forcibly by setting bit CLBUF in the Control Function register. A total of 8 kbytes RAM is available for buffering.

## 8.4 Microcontroller interface and microcontroller handler

The microcontroller handler allows the external microcontroller or microprocessor to access the register set in the Philips SIE as well as the DMA handler. The initialization of the DMA configuration is done through the microcontroller handler.

## 8.5 OTG SRP module

The OTG supplement defines a Session Request Protocol (SRP), which allows a B-device to request the A-device to turn on  $V_{BUS}$  and start a session. This protocol allows the A-device, which may be battery-powered, to conserve power by turning off  $V_{BUS}$  when there is no bus activity while still providing a means for the B-device to initiate bus activity.

Any A-device, including a PC or laptop, can respond to SRP. Any B-device, including a standard USB peripheral, can initiate SRP.

The ISP1582 is a device that can initiate SRP.

## 8.6 Philips high-speed transceiver

### 8.6.1 Philips Parallel Interface Engine (PIE)

In the high-speed (HS) transceiver, the Philips PIE interface uses a 16-bit parallel bidirectional data interface. The functions of the HS module also include bit-stuffing or destuffing and Non-Return-to-Zero Inverted (NRZI) encoding or decoding logic.

### 8.6.2 Peripheral circuit

To maintain a constant current driver for HS transmit circuits and to bias other analog circuits, an internal band gap reference circuit and an RREF resistor form the reference current. This circuit requires an external precision resistor ( $12.0\text{ k}\Omega \pm 1\%$ ) connected to the analog ground.

### 8.6.3 HS detection

The ISP1582 handles more than one electrical state—full-speed (FS) or high-speed (HS)—under the USB specification. When the USB cable is connected from the peripheral to the host controller, the ISP1582 defaults to the FS state until it sees a bus reset from the host controller.

During the bus reset, the peripheral initiates an HS chirp to detect whether the host controller supports Hi-Speed USB or Original USB. Chirping must be done with the pull-up resistor connected and the internal termination resistors disabled. If the HS handshake shows that there is an HS host connected, then the ISP1582 switches to the HS state.

In the HS state, the ISP1582 should observe the bus for periodic activity. If the bus remains inactive for 3 ms, the peripheral switches to the FS state to check for a Single-Ended Zero (SE0) condition on the USB bus. If an SE0 condition is detected for the designated time (100  $\mu$ s to 875  $\mu$ s; refer to section 7.1.7.6 of the USB specification Rev. 2.0), the ISP1582 switches to the HS chirp state to perform an HS detection handshake. Otherwise, the ISP1582 remains in the FS state adhering to the bus-suspend specification.

## 8.7 Philips Serial Interface Engine (SIE)

The Philips SIE implements the full USB protocol layer. It is completely hardwired for speed and needs no firmware intervention. The functions of this block include: synchronization pattern recognition, parallel or serial conversion, bit (de)stuffing, CRC checking or generation, Packet Identifier (PID) verification or generation, address recognition, handshake evaluation or generation.

## 8.8 SoftConnect

The connection to the USB is established by pulling pin DP (for full-speed devices) HIGH through a 1.5 k $\Omega$  pull-up resistor. In the ISP1582, an external 1.5 k $\Omega$  pull-up resistor must be connected between pin RPU and 3.3 V. Pin RPU connects the pull-up resistor to pin DP, when bit SOFTCT in the Mode register is set (see [Table 20](#) and [Table 21](#)). After a hardware reset, the pull-up resistor is disconnected by default (bit SOFTCT = 0). The USB bus reset does not change the value of bit SOFTCT.

When the  $V_{BUS}$  is not present, the SOFTCT bit must be set to logic 0 to comply with the back-drive voltage.

## 8.9 System controller

The system controller implements the USB power-down capabilities of the ISP1582. Registers are protected against data corruption during wake-up following a resume (from the suspend state) by locking the write access until an unlock code has been written in the Unlock Device register (see [Table 73](#) and [Table 74](#)).

## 8.10 Output pins status

[Table 3](#) illustrates the behavior of output pins when  $V_{CC(I/O)}$  is supplied with  $V_{CC}$  in various operating conditions.

Table 3: ISP1582 pin status<sup>[1]</sup>

V <sub>CC</sub>	V <sub>CC(I/O)</sub>	State	Pin				
			RESET_N	INT_N	SUSPEND	DREQ	DATA[15:0]
0 V	V <sub>CC</sub>	dead <sup>[2]</sup>	X	X	X	X	X
0 V	V <sub>CC</sub>	plug-out <sup>[3]</sup>	X	LOW	HIGH	high-Z	input
0 V → 3.3 V	V <sub>CC</sub>	plug-in <sup>[4]</sup>	X	LOW	HIGH	high-Z	high-Z
3.3 V	V <sub>CC</sub>	reset	LOW	HIGH	LOW	high-Z	high-Z
3.3 V	V <sub>CC</sub>	normal	HIGH	HIGH	LOW	high-Z	high-Z

[1] X: Don't care.

[2] Dead: The USB cable is plugged-out and V<sub>CC(I/O)</sub> is not available.

[3] Plug-out: The USB cable is not present but V<sub>CC(I/O)</sub> is available.

[4] Plug-in: The USB cable is being plugged-in and V<sub>CC(I/O)</sub> is available.

## 8.11 Interrupt

### 8.11.1 Interrupt output pin

The Interrupt Configuration register of the ISP1582 controls the behavior of the INT output pin. The polarity and signaling mode of pin INT can be programmed by setting bits INTPOL and INTLVL of the Interrupt Configuration register (R/W: 10h); see [Table 24](#). Bit GLINTENA of the Mode register (R/W: 0Ch) is used to enable pin INT. Default settings after reset are active LOW and level mode. When pulse mode is selected, a pulse of 60 ns is generated when the OR-ed combination of all interrupt bits changes from logic 0 to logic 1.

[Figure 4](#) shows the relationship between the interrupt events and pin INT.

Each of the indicated USB and DMA events is logged in a status bit of the Interrupt register and the DMA Interrupt Reason register, respectively. Corresponding bits in the Interrupt Enable register and the DMA Interrupt Enable register determine whether or not an event will generate an interrupt.

Interrupts can be masked globally by means of bit GLINTENA of the Mode register; see [Table 21](#).

Field CDBGMOD[1:0] of the Interrupt Configuration register controls the generation of the INT signals for the control pipe. Field DDBGMODIN[1:0] of the Interrupt Configuration register controls the generation of the INT signals for the IN pipe. Field DDBGMODOUT[1:0] of the Interrupt Configuration register controls the generation of the INT signals for the OUT pipe; see [Table 25](#).

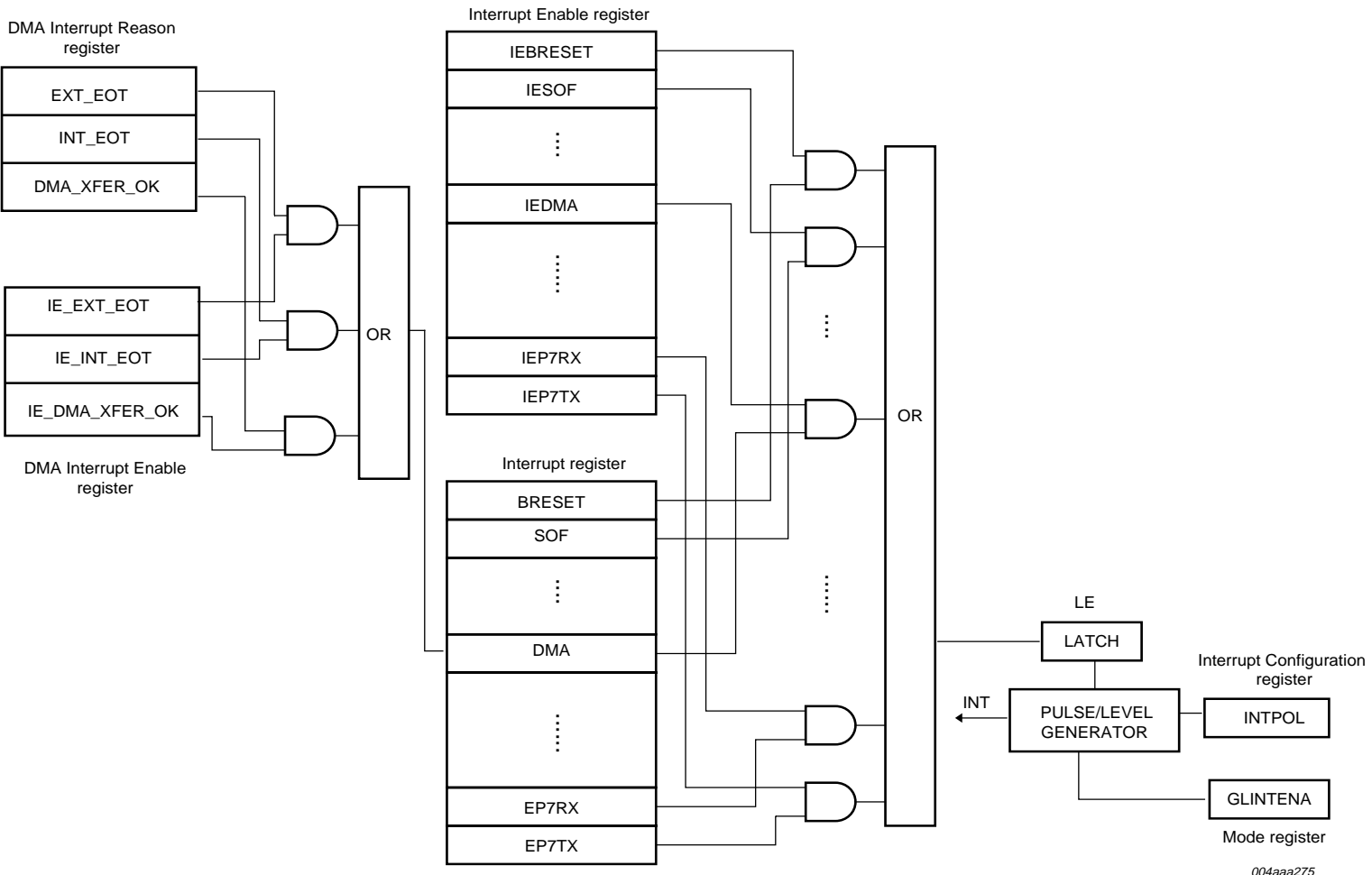

004aaa275

Fig 4. Interrupt logic.

8.11.2 Interrupt control

Bit GLINTENA in the Mode register is a global enable/disable bit. The behavior of this bit is given in Figure 5.

Event A: When an interrupt event occurs (for example, SOF interrupt) with bit GLINTENA set to logic 0, an interrupt will not be generated at pin INT. It will, however, be registered in the corresponding Interrupt register bit.

Event B: When bit GLINTENA is set to logic 1, pin INT is asserted because bit SOF in the Interrupt register is already set.

Event C: If the firmware sets bit GLINTENA to logic 0, pin INT will still be asserted. The bold dashed line shows the desired behavior of pin INT.

Deassertion of pin INT can be achieved either by clearing all the Interrupt register or the DMA Interrupt Reason register, depending on the event.

**Remark:** When clearing an interrupt event, perform write to all the bytes of the register.

For more information on interrupt control, see Section 9.2.2, Section 9.2.5 and Section 9.5.1.

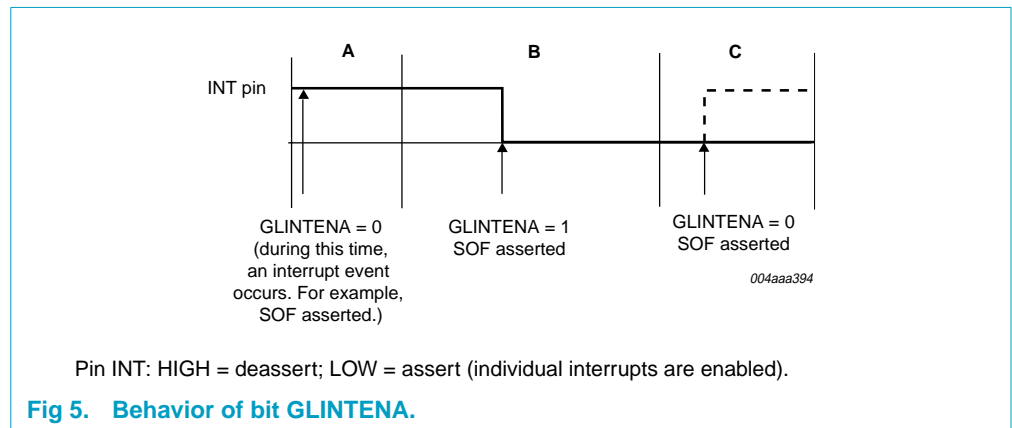

8.12 V<sub>BUS</sub> sensing

Pin V<sub>BUS</sub> is one of the ways to wake up the clock when the ISP1582 is suspended with bit CLK\_AON set to logic 0 (clock off option).

To detect whether the host is connected or not, that is V<sub>BUS</sub> sensing, a 1 MΩ resistor and a 1 μF electrolytic capacitor must be added to damp the overshoot upon plug-in.

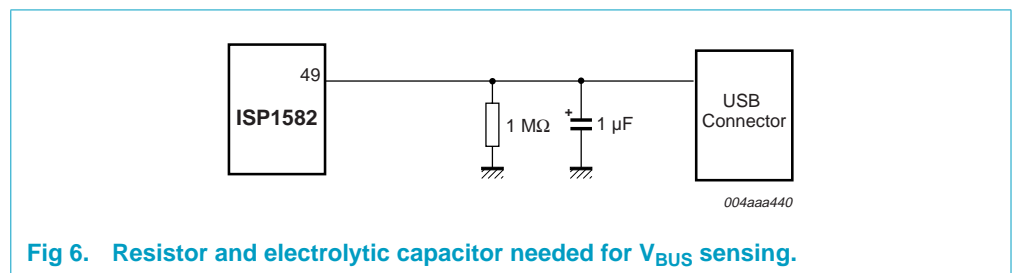

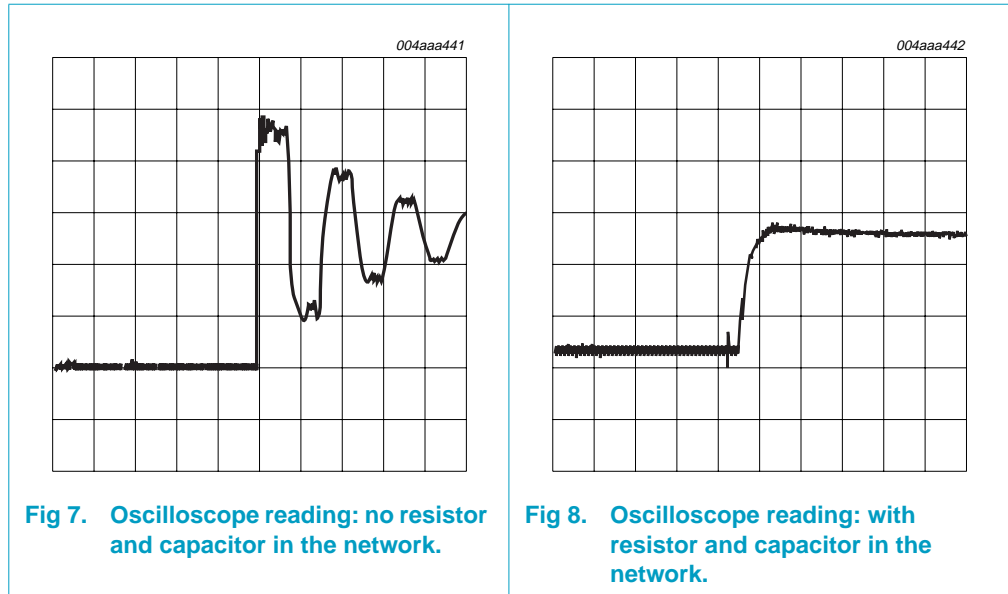

### 8.13 Power-on reset

The ISP1582 requires a minimum pulse width of 500  $\mu$ s.

Pin RESET\_N can be either connected to  $V_{CC}$  (using the internal POR circuit) or externally controlled (by the microcontroller, ASIC, and so on). When  $V_{CC}$  is directly connected to pin RESET\_N, the internal pulse width  $t_{PORP}$  will be typically 200 ns.

The power-on reset function can be explained by viewing the dips at t2-t3 and t4-t5 on the  $V_{CC(POR)}$  curve (Figure 9).

**t0** — The internal POR starts with a HIGH level.

**t1** — The detector will see the passing of the trip level and a delay element will add another  $t_{PORP}$  before it drops to LOW.

**t2-t3** — The internal POR pulse will be generated whenever  $V_{CC(POR)}$  drops below  $V_{trip}$  for more than 11  $\mu$ s.

**t4-t5** — The dip is too short ( $< 11 \mu$ s) and the internal POR pulse will not react and will remain LOW.

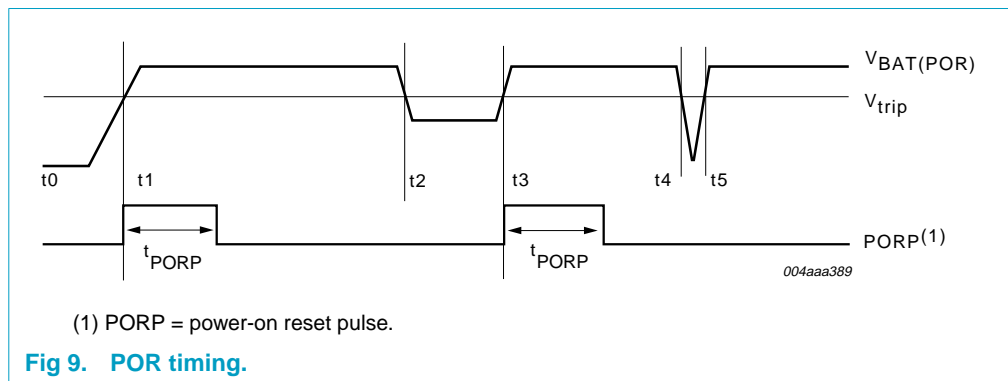
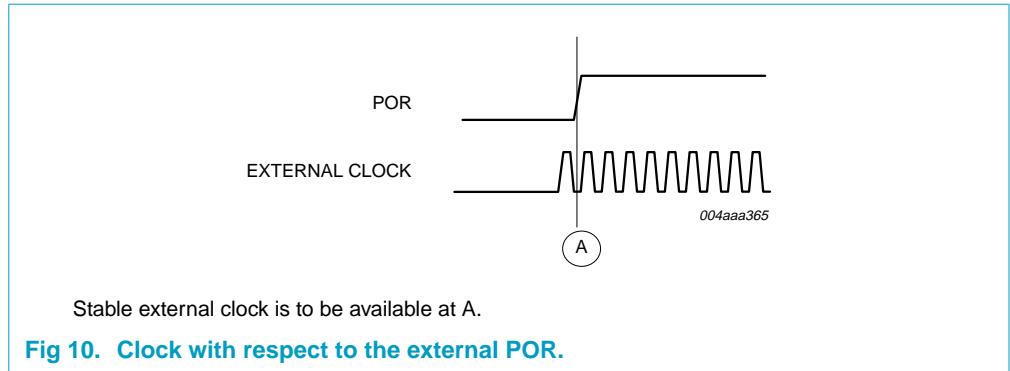

Figure 10 shows the availability of the clock with respect to the external POR.



### 8.14 Power supply

The ISP1582 can be powered by  $3.3\text{ V} \pm 0.3\text{ V}$ , and 3.3 V at the interface. For connection details, see [Figure 11](#).

If the ISP1582 is powered by  $V_{CC} = 3.3\text{ V}$ , an integrated 3.3 V-to-1.8 V voltage regulator provides a 1.8 V supply voltage for the internal logic.

In sharing mode (that is, when  $V_{CC}$  is not present and  $V_{CC(I/O)}$  is present), all the I/O pins are in three-state, the interrupt pin is connected to ground, and the suspend pin is connected to  $V_{CC(I/O)}$ . See [Table 3](#).

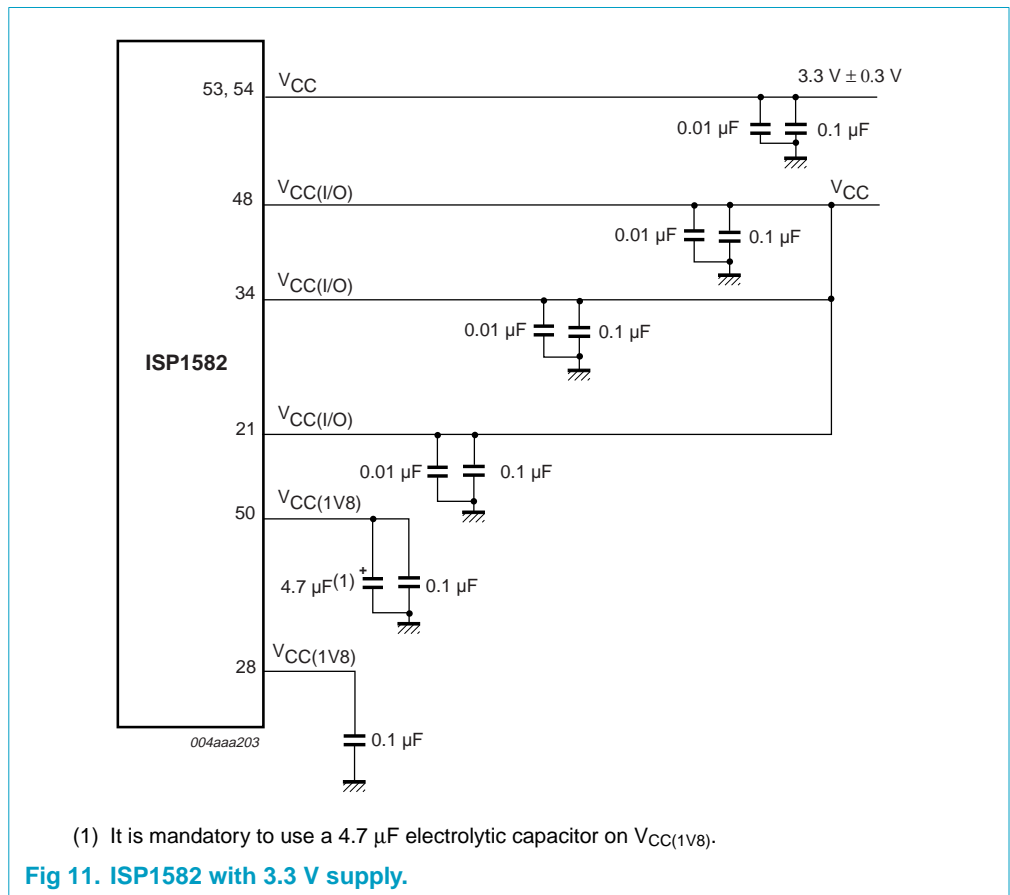

Table 4 shows power modes in which the ISP1582 can be operated.

Table 4: Power modes

V <sub>CC</sub>	V <sub>CC(I/O)</sub>	Power mode
V <sub>BUS</sub> <sup>[1]</sup>	V <sub>BUS</sub> <sup>[2]</sup>	bus-powered
self-powered	self-powered	self-powered
V <sub>BUS</sub> <sup>[1]</sup>	self-powered	power-sharing (hybrid)

[1] Power supply to the IC (V<sub>CC</sub>) is 3.3 V. Therefore, if the application is bus-powered, a 3.3 V regulator needs to be used.

[2] V<sub>CC(I/O)</sub> = V<sub>CC</sub>. If the application is bus-powered, a voltage regulator needs to be used.

8.14.1 Power-sharing mode

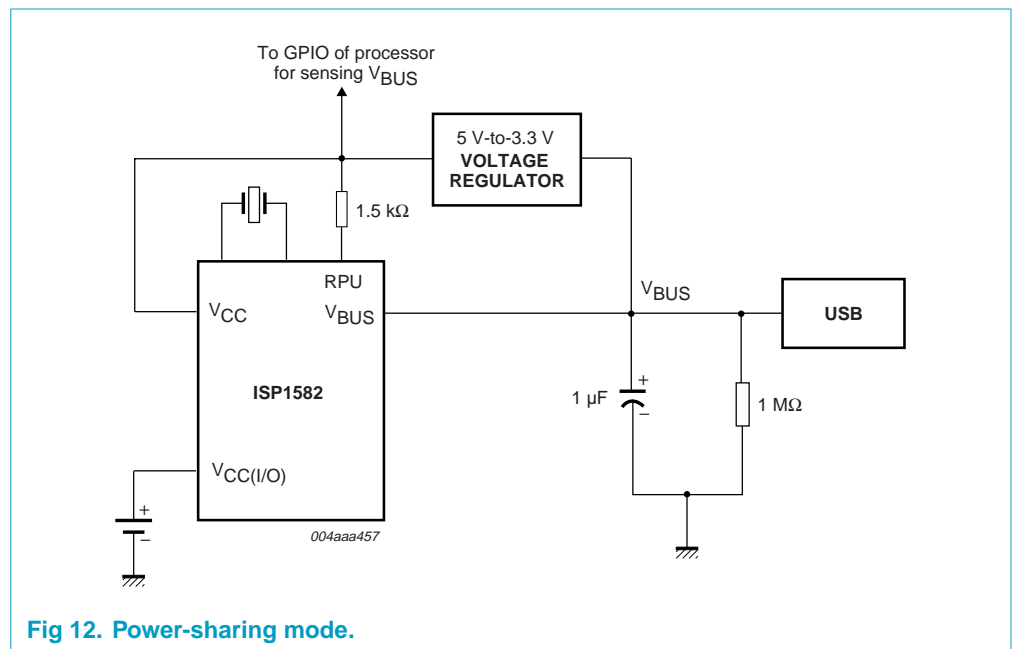

Fig 12. Power-sharing mode.

As can be seen in Figure 12, in power-sharing mode, V<sub>CC</sub> is supplied by the output of the 5 V-to-3.3 V voltage regulator. The input to the regulator is from V<sub>BUS</sub>. V<sub>CC(I/O)</sub> is supplied through the power source of the system. When the USB cable is plugged in, the ISP1582 goes through the power-on reset cycle. In this mode, OTG is disabled.

The processor will experience continuous interrupt because the default status of the interrupt pin when operating in sharing mode with the V<sub>BUS</sub> not present is LOW. To overcome this, implement external V<sub>BUS</sub> sensing circuitry. The output from the voltage regulator can be connected to pin GPIO of the processor to qualify the interrupt from the ISP1582.

**Remark:** When the core power is removed, the ISP1582 must be reset using the RESET\_N pin. The reset pulse width must be 2 ms.

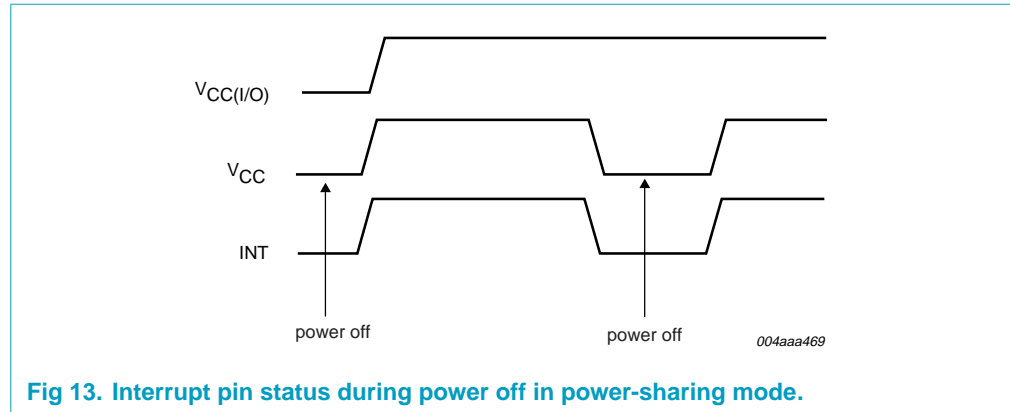

Fig 13. Interrupt pin status during power in power-sharing mode.

Table 5: Operation truth table for SoftConnect

ISP1582 operation	Power supply				Bit SOFTCT in Mode register
	V <sub>CC</sub>	V <sub>CC(I/O)</sub>	RPU (3.3 V)	V <sub>BUS</sub>	
Normal bus operation	3.3 V	3.3 V	3.3 V	5 V	enabled
Core power is lost	0 V	3.3 V	0 V	0 V	not applicable

Table 6: Operation truth table for clock off during suspend

ISP1582 operation	Power supply				Clock off during suspend
	V <sub>CC</sub>	V <sub>CC(I/O)</sub>	RPU (3.3 V)	V <sub>BUS</sub>	
Clock will wake up: After resume and After a bus reset	3.3 V	3.3 V	3.3 V	5 V	enabled
Core power is lost	0 V	3.3 V	0 V	0 V	not applicable

Table 7: Operation truth table for back voltage compliance

ISP1582 operation	Power supply				Bit SOFTCT in Mode register
	V <sub>CC</sub>	V <sub>CC(I/O)</sub>	RPU (3.3 V)	V <sub>BUS</sub>	
Back voltage is not measured in this mode	3.3 V	3.3 V	3.3 V	5 V	enabled
Back voltage is not an issue because core power is lost	0 V	3.3 V	0 V	0 V	not applicable

Table 8: Operation truth table for OTG

ISP1582 operation	Power supply				OTG register
	V <sub>CC</sub>	V <sub>CC(I/O)</sub>	RPU (3.3 V)	V <sub>BUS</sub>	
SRP is not applicable	3.3 V	3.3 V	3.3 V	5 V	not applicable
OTG is not possible because V <sub>BUS</sub> is not present and so core power is lost	0 V	3.3 V	0 V	0 V	not applicable

8.14.2 Self-powered mode

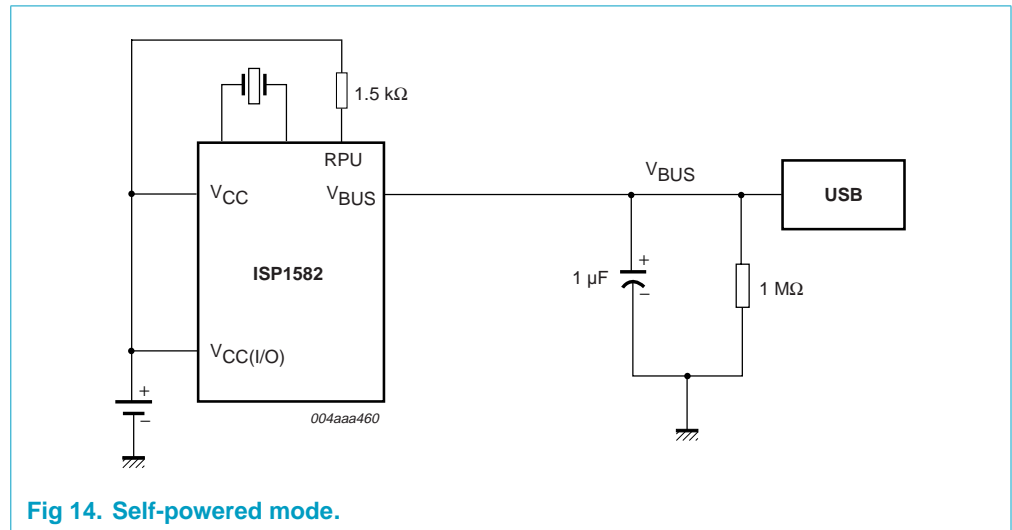

Fig 14. Self-powered mode.

In self-powered mode,  $V_{CC}$  and  $V_{CC(I/O)}$  are supplied by the system. Bit SOFTCT in the Mode register must be always logic 1. See Figure 14.

Table 9: Operation truth table for SoftConnect

ISP1582 operation	Power supply				Bit SOFTCT in Mode register
	$V_{CC}$	$V_{CC(I/O)}$	RPU (3.3 V)	$V_{BUS}$	
Normal bus operation	3.3 V	3.3 V	3.3 V	5 V	enabled
No pull-up on DP	3.3 V	3.3 V	3.3 V	0 V <sup>[1]</sup>	disabled

[1] When the USB cable is removed, SoftConnect is disabled.

Table 10: Operation truth table for clock off during suspend

ISP1582 operation	Power supply				Clock off during suspend
	$V_{CC}$	$V_{CC(I/O)}$	RPU (3.3 V)	$V_{BUS}$	
Clock will wake up: After resume and After a bus reset	3.3 V	3.3 V	3.3 V	5 V	enabled
Clock will wake up: After detecting the presence of $V_{BUS}$	3.3 V	3.3 V	3.3 V	0 V => 5 V	enabled

Table 11: Operation truth table for back voltage compliance

ISP1582 operation	Power supply				Bit SOFTCT in Mode register
	$V_{CC}$	$V_{CC(I/O)}$	RPU (3.3 V)	$V_{BUS}$	
Back voltage is not measured in this mode	3.3 V	3.3 V	3.3 V	5 V	enabled
Back voltage is not an issue because pull-up on DP will not be present when $V_{BUS}$ is not present	3.3 V	3.3 V	3.3 V	0 V	disabled

Table 12: Operation truth table for OTG

ISP1582 operation	Power supply				OTG register
	V <sub>CC</sub>	V <sub>CC(I/O)</sub>	RPU (3.3 V)	V <sub>BUS</sub>	
SRP is not applicable	3.3 V	3.3 V	3.3 V	5 V	not applicable
SRP is possible	3.3 V	3.3 V	3.3 V	0 V	operational

8.14.3 Bus-powered mode

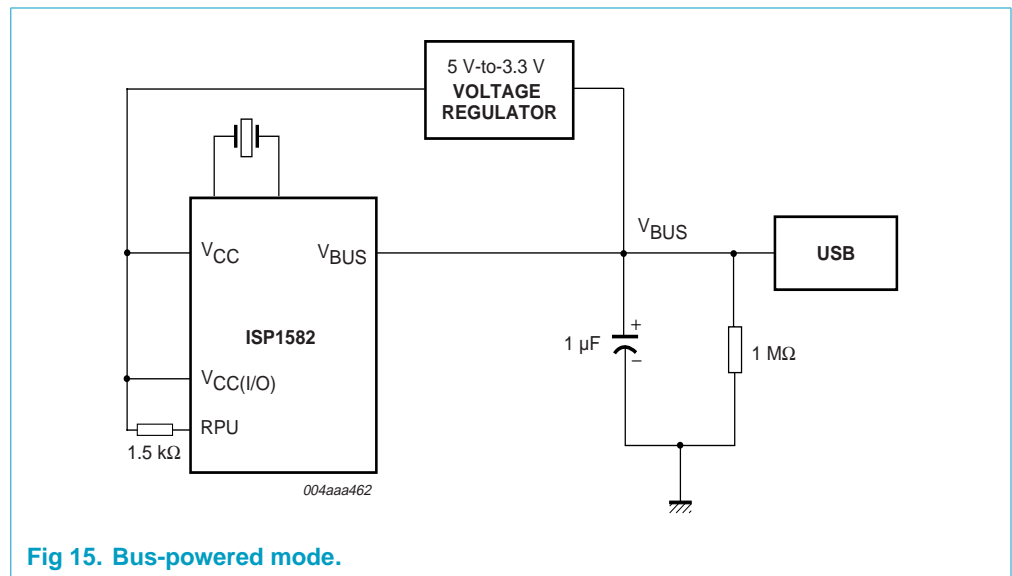

Fig 15. Bus-powered mode.

In bus-powered mode (see Figure 15), V<sub>CC</sub> and V<sub>CC(I/O)</sub> are supplied by the output of the 5 V-to-3.3 V voltage regulator. The input to the regulator is from V<sub>BUS</sub>. On plugging in of the USB cable, the ISP1582 goes through the power-on reset cycle. In this mode, OTG is disabled.

Table 13: Operation truth table for SoftConnect

ISP1582 operation	Power supply				Bit SOFTCT in Mode register
	V <sub>CC</sub>	V <sub>CC(I/O)</sub>	RPU (3.3 V)	V <sub>BUS</sub>	
Normal bus operation	3.3 V	3.3 V	3.3 V	5 V	enabled
Power loss	0 V	0 V	0 V	0 V	not applicable

Table 14: Operation truth table for clock off during suspend

ISP1582 operation	Power supply				Clock off during suspend
	V <sub>CC</sub>	V <sub>CC(I/O)</sub>	RPU (3.3 V)	V <sub>BUS</sub>	
Clock will wake up: After resume and After a bus reset	3.3 V	3.3 V	3.3 V	5 V	enabled
Power loss	0 V	0 V	0 V	0 V	not applicable

Table 15: Operation truth table for back voltage compliance

ISP1582 operation	Power supply				Bit SOFTCT in Mode register
	V <sub>CC</sub>	V <sub>CC(I/O)</sub>	RPU (3.3 V)	V <sub>BUS</sub>	
Back voltage is not measured in this mode	3.3 V	3.3 V	3.3 V	5 V	enabled
Power loss	0 V	0 V	0 V	0 V	not applicable

Table 16: Operation truth table for OTG

ISP1582 operation	Power supply				OTG register
	V <sub>CC</sub>	V <sub>CC(I/O)</sub>	RPU (3.3 V)	V <sub>BUS</sub>	
SRP is not applicable	3.3 V	3.3 V	3.3 V	5 V	not applicable
Power loss	0 V	0 V	0 V	0 V	not applicable

## 9. Register description

Table 17: Register overview

Name	Destination	Address	Description	Size (bytes)	Reference
<b>Initialization registers</b>					
Address	device	00h	USB device address and enabling	1	<a href="#">Section 9.2.1 on page 24</a>
Mode	device	0Ch	power-down options, global interrupt enable, SoftConnect	1	<a href="#">Section 9.2.2 on page 25</a>
Interrupt Configuration	device	10h	interrupt sources, trigger mode, output polarity	1	<a href="#">Section 9.2.3 on page 27</a>
OTG	device	12h	OTG implementation	1	<a href="#">Section 9.2.4 on page 28</a>
Interrupt Enable	device	14h	interrupt source enabling	4	<a href="#">Section 9.2.5 on page 30</a>
<b>Data flow registers</b>					
Endpoint Index	endpoints	2Ch	endpoint selection, data flow direction	1	<a href="#">Section 9.3.1 on page 31</a>
Control Function	endpoint	28h	endpoint buffer management	1	<a href="#">Section 9.3.2 on page 33</a>
Data Port	endpoint	20h	data access to endpoint FIFO	2	<a href="#">Section 9.3.3 on page 33</a>
Buffer Length	endpoint	1Ch	packet size counter	2	<a href="#">Section 9.3.4 on page 34</a>
Buffer Status	endpoint	1Eh	buffer status for each endpoint	1	<a href="#">Section 9.3.5 on page 35</a>
Endpoint MaxPacketSize	endpoint	04h	maximum packet size	2	<a href="#">Section 9.3.6 on page 36</a>
Endpoint Type	endpoint	08h	selects endpoint type: control, isochronous, bulk or interrupt	2	<a href="#">Section 9.3.7 on page 37</a>
<b>DMA registers</b>					
DMA Command	DMA controller	30h	controls all DMA transfers	1	<a href="#">Section 9.4.1 on page 39</a>
DMA Transfer Counter	DMA controller	34h	sets byte count for DMA transfer	4	<a href="#">Section 9.4.2 on page 40</a>
DMA Configuration	DMA controller	38h	sets GDMA configuration (counter enable, burst length, data strobing, bus width)	1	<a href="#">Section 9.4.3 on page 41</a>
DMA Hardware	DMA controller	3Ch	endian type, master or slave selection, signal polarity for DACK, DREQ, DIOW, DIOR	1	<a href="#">Section 9.4.4 on page 42</a>
DMA Interrupt Reason	DMA controller	50h	shows reason (source) for DMA interrupt	2	<a href="#">Section 9.4.5 on page 43</a>
DMA Interrupt Enable	DMA controller	54h	enables DMA interrupt sources	2	<a href="#">Section 9.4.6 on page 45</a>
DMA Endpoint	DMA controller	58h	selects endpoint FIFO, data flow direction	1	<a href="#">Section 9.4.7 on page 45</a>

Table 17: Register overview...continued

Name	Destination	Address	Description	Size (bytes)	Reference
DMA Burst Counter	DMA controller	64h	DMA burst counter	2	Section 9.4.8 on page 46
<b>General registers</b>					
Interrupt	device	18h	shows interrupt sources	4	Section 9.5.1 on page 46
Chip ID	device	70h	product ID code and hardware version	3	Section 9.5.2 on page 48
Frame Number	device	74h	last successfully received Start-Of-Frame: lower byte (byte 0) is accessed first	2	Section 9.5.3 on page 49
Scratch	device	78h	allows save or restore of firmware status during suspend	2	Section 9.5.4 on page 49
Unlock Device	device	7Ch	reenables register access after suspend	2	Section 9.5.5 on page 50
Test Mode	PHY	84h	direct setting of DP and DM states, internal transceiver test (PHY)	1	Section 9.5.6 on page 51

## 9.1 Register access

Register access depends on the bus width used. The ISP1582 uses a 16-bit bus access. For single-byte registers, the upper byte (MSByte) must be ignored.

Endpoint specific registers are indexed via the Endpoint Index register. The target endpoint must be selected before accessing the following registers:

- Buffer Length
- Buffer Status
- Control Function
- Data Port
- Endpoint MaxPacketSize
- Endpoint Type.

**Remark:** All reserved bits are not implemented. The bus and bus reset values are not defined. Therefore, writing to these reserved bits will have no effect.

## 9.2 Initialization registers

### 9.2.1 Address register (address: 00h)

This register sets the USB assigned address and enables the USB device. Table 18 shows the Address register bit allocation.

Bits DEVADDR will be cleared whenever a bus reset, a power-on reset or a soft reset occurs. Bit DEVEN will be cleared whenever a power-on reset or a soft reset occurs, and will be set after a bus reset.

In response to the standard USB request SET\_ADDRESS, the firmware must write the (enabled) device address to the Address register, followed by sending an empty packet to the host. The **new** device address is activated when the device receives acknowledgment from the host.

**Table 18: Address register: bit allocation**

Bit	7	6	5	4	3	2	1	0
Symbol	DEVEN	DEVADDR[6:0]						
Reset	0	0	0	0	0	0	0	0
Bus reset	1	0	0	0	0	0	0	0
Access	R/W	R/W	R/W	R/W	R/W	R/W	R/W	R/W

**Table 19: Address register: bit description**

Bit	Symbol	Description
7	DEVEN	Logic 1 enables the device.
6 to 0	DEVADDR[6:0]	This field specifies the USB device address.

**9.2.2 Mode register (address: 0Ch)**

This register consists of 2 bytes (bit allocation: see [Table 20](#)).

The Mode register controls resume, suspend and wake-up behavior, interrupt activity, soft reset, clock signals and SoftConnect operation.

**Table 20: Mode register: bit allocation**

Bit	15	14	13	12	11	10	9	8
Symbol	reserved						DMA CLKON	VBUSSTAT
Reset	-	-	-	-	-	-	0	-
Bus reset	-	-	-	-	-	-	0	-
Access	R	R	R	R	R	R	R/W	R
Bit	7	6	5	4	3	2	1	0
Symbol	CLKAON	SNDRSU	GOSUSP	SFRESET	GLINTENA	WKUPCS	PWRON	SOFTCT
Reset	0	0	0	0	0	0	0	0
Bus reset	0	0	0	0	unchanged	0	0	unchanged
Access	R/W	R/W	R/W	R/W	R/W	R/W	R/W	R/W

**Table 21: Mode register: bit description**

Bit	Symbol	Description
15 to 10	-	reserved
9	DMACLKON	<b>1</b> — Supply clock to the DMA circuit. <b>0</b> — Power save mode; the DMA circuit will stop completely to save power.
8	VBUSSTAT	This bit reflects the V <sub>BUS</sub> pin status.

Table 21: Mode register: bit description...continued

Bit	Symbol	Description
7	CLKAON	<b>Clock Always On:</b> Logic 1 indicates that the internal clocks are always running when in the suspend state. Logic 0 switches off the internal oscillator and PLL when the device goes into suspend mode. The device will consume less power if this bit is set to logic 0. The clock is stopped after a delay of approximately 2 ms, following which bit GOSUSP is set.
6	SNDRSU	<b>Send Resume:</b> Writing logic 1, followed by logic 0 will generate an upstream resume signal of 10 ms duration, after a 5 ms delay.
5	GOSUSP	<b>Go Suspend:</b> Writing logic 1, followed by logic 0 will activate suspend mode.
4	SFRESET	<b>Soft Reset:</b> Writing logic 1, followed by logic 0 will enable a software-initiated reset to the ISP1582. A soft reset is similar to a hardware-initiated reset (via pin RESET_N).
3	GLINTENA	<b>Global Interrupt Enable:</b> Logic 1 enables all interrupts. Individual interrupts can be masked by clearing the corresponding bits in the Interrupt Enable register.  When this bit is not set, an unmasked interrupt will not generate an interrupt trigger on the interrupt pin. If global interrupt, however, is enabled while there is any pending unmasked interrupt, an interrupt signal will be immediately generated on the interrupt pin. (If the interrupt is set to pulse mode, the interrupt events that were generated before the global interrupt is enabled may be dropped).
2	WKUPCS	<b>Wake up on Chip Select:</b> Logic 1 enables wake-up from suspend mode through a valid register read on the ISP1582. (A read will invoke the chip clock to restart. If you write to the register before the clock gets stable, it may cause malfunctioning).
1	PWRON	Pin SUSPEND output control.  <b>0</b> — Pin SUSPEND is HIGH when the ISP1582 is in the suspend state. Otherwise, pin SUSPEND is LOW.  <b>1</b> — When the device is woken up from the suspend state, there will be a 1 ms active HIGH pulse on pin SUSPEND. Pin SUSPEND will remain LOW in all other states.
0	SOFTCT	<b>SoftConnect:</b> Logic 1 enables the connection of the 1.5 kΩ pull-up resistor on pin RPU to the DP line. Bus reset value: unchanged.

When SoftConnect and  $V_{BUS}$  are not present (except in OTG), the USB bus activities are not qualified. Therefore, the chip will follow the suspend command to enter suspend mode (the clock is controlled by bit CLKAON).

When  $V_{BUS}$  is off, the 1.5 kΩ pull-up resistor is disconnected from pin DP in approximately 4 ns via bit SOFTCT in the Mode register and a suspend interrupt is set with some latency (debounce and disqualify USB traffic).

When bit SOFTCT is set to logic 0, no interrupt is generated. The firmware can issue a suspend command, followed by the resetting of bit SOFTCT to suspend the chip.

If OTG is logic 1, the pull-up resistor on pin DP depends on D+ line ( $V_{BUS}$  sensing status). Bit DP operates as normal, so the firmware must mask suspend and wake-up interrupt events. When SRP is completed, the device should clear OTG.

If OTG is logic 0, the status of the pull-up resistor on DP is referred to in [Table 22](#).

**Table 22: Status of the chip**

V <sub>BUS</sub>	SoftConnect = on	SoftConnect = off
On	pull-up resistor on DP	pull-up resistor on DP is removed; suspend interrupt is immediately set, regardless of the D+ and D- signals
Off	pull-up resistor on DP is removed; suspend interrupt is immediately set, regardless of the D+ and D- signals	pull-up resistor on DP is removed; suspend interrupt is immediately set, regardless of the D+ and D- signals

**9.2.3 Interrupt Configuration register (address: 10h)**

This 1-byte register determines the behavior and polarity of the INT output. The bit allocation is shown in [Table 23](#). When the USB SIE receives or generates an ACK, NAK or STALL, it will generate interrupts depending on three Debug mode fields.

**CDBGMOD[1:0]** — Interrupts for the control endpoint 0

**DDBGMODIN[1:0]** — Interrupts for the DATA IN endpoints 1 to 7

**DDBGMODOUT[1:0]** — Interrupts for the DATA OUT endpoints 1 to 7.

The Debug mode settings for CDBGMOD, DDBGMODIN and DDBGMODOUT allow you to individually configure when the ISP1582 sends an interrupt to the external microprocessor. [Table 25](#) lists the available combinations.

Bit INTPOL controls the signal polarity of the INT output: active HIGH or LOW, rising or falling edge. For level-triggering, bit INTLVL must be made logic 0. By setting INTLVL to logic 1, an interrupt will generate a pulse of 60 ns (edge-triggering).

**Table 23: Interrupt Configuration register: bit allocation**

Bit	7	6	5	4	3	2	1	0
<b>Symbol</b>	CDBGMOD[1:0]		DDBGMODIN[1:0]		DDBGMODOUT[1:0]		INTLVL	INTPOL
<b>Reset</b>	1	1	1	1	1	1	0	0
<b>Bus reset</b>	1	1	1	1	1	1	unchanged	unchanged
<b>Access</b>	R/W	R/W	R/W	R/W	R/W	R/W	R/W	R/W

**Table 24: Interrupt Configuration register: bit description**

Bit	Symbol	Description
7 to 6	CDBGMOD[1:0]	<b>Control 0 Debug Mode:</b> For values, see <a href="#">Table 25</a>
5 to 4	DDBGMODIN[1:0]	<b>Data Debug Mode IN:</b> For values, see <a href="#">Table 25</a>
3 to 2	DDBGMODOUT[1:0]	<b>Data Debug Mode OUT:</b> For values, see <a href="#">Table 25</a>
1	INTLVL	<b>Interrupt Level:</b> Selects signaling mode on output INT (0 = level; 1 = pulsed). In pulsed mode, an interrupt produces a 60 ns pulse. Bus reset value: unchanged.
0	INTPOL	<b>Interrupt Polarity:</b> Selects signal polarity on output INT (0 = active LOW; 1 = active HIGH). Bus reset value: unchanged.

**Table 25: Debug mode settings**

Value	CDBGMOD	DDBGMODIN	DDBGMODOUT
00h	interrupt on all ACK and NAK	interrupt on all ACK and NAK	interrupt on all ACK, NYET and NAK
01h	interrupt on all ACK.	interrupt on ACK	interrupt on ACK and NYET
1Xh	interrupt on all ACK and first NAK <sup>[1]</sup>	interrupt on all ACK and first NAK <sup>[1]</sup>	interrupt on all ACK, NYET and first NAK <sup>[1]</sup>

[1] First NAK: the first NAK on an IN or OUT token after a previous ACK response.

**9.2.4 OTG register (address: 12h)**

The bit allocation of the OTG register is given in [Table 26](#).

**Table 26: OTG register: bit allocation**

Bit	7	6	5	4	3	2	1	0
Symbol	reserved		DP	BSESSVALID	INITCOND	DISCV	VP	OTG
Reset	-	-	0	-	-	0	0	0
Bus reset	-	-	0	-	-	0	0	0
Access	-	-	R/W	R/W	R/W	R/W	R/W	R/W

**Table 27: OTG register: bit description<sup>[1][2][3]</sup>**

Bit	Symbol	Description
7 to 6	-	reserved
5	DP	When set, data-line pulsing is started. The default value of this bit is logic 0. This bit must be cleared when data-line pulsing is completed.
4	BSESS VALID	<p>The device can initiate another <math>V_{BUS}</math> discharge sequence after data-line pulsing and <math>V_{BUS}</math> pulsing, and before it clears this bit and detects a session valid.</p> <p>This bit is latched to logic 1 once <math>V_{BUS}</math> exceeds the B-device session valid threshold. Once set, it remains at logic 1. To clear this bit, write logic 1. (The ISP1582 continuously updates this bit to logic 1 when the B-session is valid. If the B-session is valid after it is cleared, it is set back to logic 1 by the ISP1582).</p> <p><b>0</b> — It implies that SRP has failed. To proceed to a normal operation, the device can restart SRP, clear bit OTG or proceed to an error handling process.</p> <p><b>1</b> — It implies that the B-session is valid. The device clears bit OTG, goes into normal operation mode, and sets bit SOFTCT (DP pull-up) in the Mode register. The OTG host has a maximum of 5 s before it responds to a session request. During this period, the ISP1582 may request to suspend. Therefore, the device firmware must wait for sometime if it wishes to know the SRP result (success—if there is minimum response from the host within 5 s; failure—if there is no response from the host within 5 s).</p>

Table 27: OTG register: bit description<sup>[1][2][3]</sup>...continued

Bit	Symbol	Description
3	INIT COND	<p>Write logic 1 to clear this bit. The device clears this bit, and waits for more than 2 ms to check the bit status. If it reads logic 0, it means that <math>V_{BUS}</math> remains lower than 0.8 V, and DP or DM at SE0 during the elapsed time is cleared. The device can then start a B-device SRP. If it reads logic 1, it means that the initial condition of an SRP is violated. So, the device should abort SRP.</p> <p>The bit is set to logic 1 by the ISP1582 when initial conditions are not met, and only writing logic 1 clears the bit. (If initial conditions are not met after this bit has been cleared, it will be set again).</p> <p><b>Remark:</b> This implementation does not cover the case if an initial SRP condition is violated when this bit is read and data-line pulsing is started.</p>
2	DISCV	Set to logic 1 to discharge $V_{BUS}$ . The device discharges $V_{BUS}$ before starting a new SRP. The discharge can take as long as 30 ms for $V_{BUS}$ to be charged less than 0.8 V. This bit must be cleared (write logic 0) before starting a session end detection.
1	VP	Set to logic 1 to start $V_{BUS}$ pulsing. This bit must be set for more than 16 ms and must be cleared before 26 ms.
0	OTG	<p><b>1</b> — Enables the OTG function. The <math>V_{BUS}</math> sensing functionality will be bypassed.</p> <p><b>0</b> — Normal operation. All OTG control bits will be masked. Status bits are undefined.</p>

[1] No interrupt is designed for OTG. The  $V_{BUS}$  interrupt, however, may assert as a side effect during the  $V_{BUS}$  pulsing (see note 2).

[2] When OTG is in progress, the  $V_{BUS}$  interrupt may be set because  $V_{BUS}$  is charged over  $V_{BUS}$  sensing threshold or the OTG host has turned on the  $V_{BUS}$  supply to the device. Even if the  $V_{BUS}$  interrupt is found during SRP, the device should complete data-line pulsing and  $V_{BUS}$  pulsing before starting the B\_SESSION\_VALID detection.

[3] OTG implementation applies to the device with self-power capability. If the device works in sharing mode, it should provide a switch circuit to supply power to the ISP1582 core during SRP.

### Session Request Protocol (SRP):

The ISP1582 can initiate an SRP. The B-device initiates SRP by data-line pulsing followed by  $V_{BUS}$  pulsing. The A-device can detect either data-line pulsing or  $V_{BUS}$  pulsing.

The ISP1582 can initiate the B-device SRP by performing the following steps:

1. Detect initial conditions: read bit INITCOND of the OTG register.
2. Start data-line pulsing: set bit DP of the OTG register to logic 1.
3. Wait for 5 ms to 10 ms.
4. Stop data-line pulsing: set bit DP of the OTG register to logic 0.
5. Start  $V_{BUS}$  pulsing: set bit VP of the OTG register to logic 1.
6. Wait for 10 ms to 20 ms.
7. Stop  $V_{BUS}$  pulsing: set bit VP of the OTG register to logic 0.
8. Discharge  $V_{BUS}$  for about 30 ms: optional by using bit DISCV of the OTG register.

- Detect bit BSESSVALID of the OTG register for a successful SRP with bit OTG disabled.

The B-device must complete both data-line pulsing and V<sub>BUS</sub> pulsing within 100 ms.

**Remark:** When disabling, OTG data-line pulsing bit DP and V<sub>BUS</sub> pulsing bit VP must be cleared by writing logic 1.

### 9.2.5 Interrupt Enable register (address: 14h)

This register enables or disables individual interrupt sources. The interrupt for each endpoint can be individually controlled via the associated bits IEPnRX or IEPnTX, here n represents the endpoint number. All interrupts can be globally disabled through bit GLINTENA in the Mode register (see Table 20).

An interrupt is generated when the USB SIE receives or generates an ACK or NAK on the USB bus. The interrupt generation depends on Debug mode settings of bit fields CDBGMOD[1:0], DDBGMODIN[1:0] and DDBGMODOUT[1:0].

All data IN transactions use the Transmit buffers (TX), which are handled by bits DDBGMODIN. All data OUT transactions go via the Receive buffers (RX), which are handled by bits DDBGMODOUT. Transactions on control endpoint 0 (IN, OUT and SETUP) are handled by bits CDBGMOD.

Interrupts caused by events on the USB bus (SOF, Pseudo SOF, suspend, resume, bus reset, setup and high-speed status) can also be individually controlled. A bus reset disables all enabled interrupts except bit IEBRST (bus reset), which remains unchanged.

The Interrupt Enable register consists of 4 bytes. The bit allocation is given in Table 28.

Table 28: Interrupt Enable register: bit allocation

Bit	31	30	29	28	27	26	25	24
Symbol	reserved						IEP7TX	IEP7RX
Reset	-	-	-	-	-	-	0	0
Bus Reset	-	-	-	-	-	-	0	0
Access	-	-	-	-	-	-	R/W	R/W
Bit	23	22	21	20	19	18	17	16
Symbol	IEP6TX	IEP6RX	IEP5TX	IEP5RX	IEP4TX	IEP4RX	IEP3TX	IEP3RX
Reset	0	0	0	0	0	0	0	0
Bus Reset	0	0	0	0	0	0	0	0
Access	R/W	R/W	R/W	R/W	R/W	R/W	R/W	R/W
Bit	15	14	13	12	11	10	9	8
Symbol	IEP2TX	IEP2RX	IEP1TX	IEP1RX	IEP0TX	IEP0RX	reserved	IEP0SETUP
Reset	0	0	0	0	0	0	-	0
Bus Reset	0	0	0	0	0	0	-	0
Access	R/W	R/W	R/W	R/W	R/W	R/W	R/W	R/W

Bit	7	6	5	4	3	2	1	0
Symbol	IEVBUS	IEDMA	IEHS_STA	IERESM	IESUSP	IEPSOF	IESOF	IEBRST
Reset	0	0	0	0	0	0	0	0
Bus Reset	0	0	0	0	0	0	0	unchanged
Access	R/W	R/W	R/W	R/W	R/W	R/W	R/W	R/W

Table 29: Interrupt Enable register: bit description

Bit	Symbol	Description
31 to 26	-	reserved
25	EP7TX	Logic 1 enables interrupt from the indicated endpoint.
24	EP7RX	Logic 1 enables interrupt from the indicated endpoint.
23	EP6TX	Logic 1 enables interrupt from the indicated endpoint.
22	EP6RX	Logic 1 enables interrupt from the indicated endpoint.
21	EP5TX	Logic 1 enables interrupt from the indicated endpoint.
20	EP5RX	Logic 1 enables interrupt from the indicated endpoint.
19	EP4TX	Logic 1 enables interrupt from the indicated endpoint.
18	EP4RX	Logic 1 enables interrupt from the indicated endpoint.
17	EP3TX	Logic 1 enables interrupt from the indicated endpoint.
16	EP3RX	Logic 1 enables interrupt from the indicated endpoint.
15	EP2TX	Logic 1 enables interrupt from the indicated endpoint.
14	EP2RX	Logic 1 enables interrupt from the indicated endpoint.
13	EP1TX	Logic 1 enables interrupt from the indicated endpoint.
12	IEP1RX	Logic 1 enables interrupt from the indicated endpoint.
11	IEP0TX	Logic 1 enables interrupt from the control IN endpoint 0.
10	IEP0RX	Logic 1 enables interrupt from the control OUT endpoint 0.
9	-	reserved
8	IEP0SETUP	Logic 1 enables interrupt for the setup data received on endpoint 0.
7	IEVBUS	Logic 1 enables interrupt for $V_{BUS}$ sensing.
6	IEDMA	Logic 1 enables interrupt on DMA status change detection.
5	IEHS_STA	Logic 1 enables interrupt on detection of a high-speed status change.
4	IERESM	Logic 1 enables interrupt on detection of a resume state.
3	IESUSP	Logic 1 enables interrupt on detection of a suspend state.
2	IEPSOF	Logic 1 enables interrupt on detection of a Pseudo SOF.
1	IESOF	Logic 1 enables interrupt on detection of an SOF.
0	IEBRST	Logic 1 enables interrupt on detection of a bus reset.

### 9.3 Data flow registers

#### 9.3.1 Endpoint Index register (address: 2Ch)

The Endpoint Index register selects a target endpoint for register access by the microcontroller. The register consists of 1 byte, and the bit allocation is shown in [Table 30](#).

The following registers are indexed:

- Buffer Length
- Buffer Status
- Control Function
- Data Port
- Endpoint MaxPacketSize
- Endpoint Type.

For example, to access the OUT data buffer of endpoint 1 using the Data Port register, the Endpoint Index register has to be written first with 02h.

**Remark:** The Endpoint Index register and the DMA Endpoint Index register must not point to the same endpoint.

**Table 30: Endpoint Index register: bit allocation**

Bit	7	6	5	4	3	2	1	0
Symbol	reserved		EP0SETUP	ENDPIDX[3:0]				DIR
Reset	-	-	0	0	0	0	0	0
Bus reset	-	-	0	0	0	0	0	0
Access	R/W	R/W	R/W	R/W	R/W	R/W	R/W	R/W

**Table 31: Endpoint Index register: bit description**

Bit	Symbol	Description
7 to 6	-	reserved
5	EP0SETUP	Selects the SETUP buffer for endpoint 0.  <b>0</b> — EP0 data buffer <b>1</b> — SETUP buffer. Must be logic 0 for access to other endpoints than endpoint 0.
4 to 1	ENDPIDX[3:0]	<b>Endpoint Index:</b> Selects the target endpoint for register access of Buffer Length, Control Function, Data Port, Endpoint Type and MaxPacketSize.
0	DIR	<b>Direction bit:</b> Sets the target endpoint as IN or OUT.  <b>0</b> — target endpoint refers to OUT (RX) FIFO <b>1</b> — target endpoint refers to IN (TX) FIFO.

**Table 32: Addressing of endpoint 0 buffers**

Buffer name	EP0SETUP	ENDPIDX	DIR
SETUP	1	00h	0
Data OUT	0	00h	0
Data IN	0	00h	1

### 9.3.2 Control Function register (address: 28h)

The Control Function register performs the buffer management on endpoints. It consists of 1 byte, and the bit configuration is given in Table 33. The register bits can stall, clear or validate any enabled data endpoint. Before accessing this register, the Endpoint Index register must be written first to specify the target endpoint.

Table 33: Control Function register: bit allocation

Bit	7	6	5	4	3	2	1	0
Symbol		reserved		CLBUF	VENDP	DSEN	STATUS	STALL
Reset	-	-	-	0	0	0	0	0
Bus reset	-	-	-	0	0	0	0	0
Access	R/W	R/W	R/W	R/W	R/W	R/W	R/W	R/W

Table 34: Control Function register: bit description

Bit	Symbol	Description
7 to 5	-	reserved
4	CLBUF	<b>Clear Buffer:</b> Logic 1 clears the RX buffer of the indexed endpoint; the TX buffer is not affected. The RX buffer is automatically cleared once the endpoint is completely read. This bit is set only when it is necessary to forcefully clear the buffer.
3	VENDP	<b>Validate Endpoint:</b> Logic 1 validates the data in the TX FIFO of an IN endpoint for sending on the next IN token. In general, the endpoint is automatically validated when its FIFO byte count has reached the endpoint MaxPacketSize. This bit is set only when it is necessary to validate the endpoint with the FIFO byte count which is below the Endpoint MaxPacketSize.
2	DSEN	<b>Data Stage Enable:</b> This bit controls the response of the ISP1582 to a control transfer. When this bit is set, the ISP1582 goes to the data stage; otherwise, the ISP1582 will NAK the data stage transfer until the firmware explicitly responds to the setup command.
1	STATUS	<b>Status Acknowledge:</b> Only applicable for control IN/OUT. This bit controls the generation of ACK or NAK during the status stage of a SETUP transfer. It is automatically cleared when the status stage is completed, or when a SETUP token is received. No interrupt signal will be generated.  <b>0</b> — Sends NAK <b>1</b> — Sends an empty packet following the IN token (host-to-peripheral) or ACK following the OUT token (peripheral-to-host).
0	STALL	<b>Stall Endpoint:</b> Logic 1 stalls the indexed endpoint. This bit is not applicable for isochronous transfers.  <b>Remark:</b> ‘Stall’ing a data endpoint will confuse the Data Toggle bit about the stalled endpoint because the internal logic picks up from where it is stalled. Therefore, the Data Toggle bit must be reset by disabling and reenabling the corresponding endpoint (by setting bit ENABLE to logic 0 or logic 1 in the Endpoint Type register) to reset the PID.

### 9.3.3 Data Port register (address: 20h)

This 2-byte register provides direct access for a microcontroller to the FIFO of the indexed endpoint. The bit allocation is shown in Table 35.

**Peripheral-to-host (IN endpoint):** After each write action, an internal counter is auto incremented by two to the next location in the TX FIFO. When all bytes have been written (FIFO byte count = endpoint MaxPacketSize), the buffer is automatically validated. The data packet will then be sent on the next IN token. When it is necessary to validate the endpoint whose byte count is less than MaxPacketSize, it can be done using the Control Function register (bit VENDP).

**Host-to-peripheral (OUT endpoint):** After each read action, an internal counter is auto decremented by two to the next location in the RX FIFO. When all bytes have been read, the buffer contents are automatically cleared. A new data packet can then be received on the next OUT token. The buffer contents can also be cleared through the Control Function register (bit CLBUF), when it is necessary to forcefully clear the contents.

**Remark:** The buffer can be automatically validated or cleared by using the Buffer Length register (see [Table 37](#)).

**Table 35: Data Port register: bit allocation**

Bit	15	14	13	12	11	10	9	8
Symbol	DATAPORT[15:8]							
Reset	0	0	0	0	0	0	0	0
Bus reset	0	0	0	0	0	0	0	0
Access	R/W	R/W	R/W	R/W	R/W	R/W	R/W	R/W
Bit	7	6	5	4	3	2	1	0
Symbol	DATAPORT[7:0]							
Reset	0	0	0	0	0	0	0	0
Bus reset	0	0	0	0	0	0	0	0
Access	R/W	R/W	R/W	R/W	R/W	R/W	R/W	R/W

**Table 36: Data Port register: bit description**

Bit	Symbol	Description
15 to 8	DATAPORT[15:8]	data (upper byte)
7 to 0	DATAPORT[7:0]	data (lower byte)

**9.3.4 Buffer Length register (address: 1Ch)**

This register determines the current packet size (DATACOUNT) of the indexed endpoint FIFO. The bit allocation is given in [Table 37](#).

The Buffer Length register is automatically loaded with the FIFO size, when the Endpoint MaxPacketSize register is written (see [Table 41](#)). A smaller value can be written when required. After a bus reset, the Buffer Length register is made zero.

**IN endpoint:** When data transfer is performed in multiples of MaxPacketSize, the Buffer Length register is not significant. This register is useful only when transferring data that is not a multiple of MaxPacketSize. The following two examples demonstrate the significance of the Buffer Length register.

Example 1: Consider that the transfer size is 512 bytes and the MaxPacketSize is programmed as 64 bytes, the Buffer Length register need not be filled. This is because the transfer size is a multiple of MaxPacketSize, and the MaxPacketSize packets will be automatically validated because the last packet is also of MaxPacketSize.

Example 2: Consider that the transfer size is 510 bytes and the MaxPacketSize is programmed as 64 bytes, the Buffer Length register should be filled with 62 bytes just before the MCU writes the last packet of 62 bytes. This ensures that the last packet, which is a short packet of 62 bytes, is automatically validated.

Use bit VENDP in the Control register if you are not using the Buffer Length register.

This is applicable only to PIO mode access.

**OUT endpoint:** The DATACOUNT value is automatically initialized to the number of data bytes sent by the host on each ACK.

**Remark:** When using a 16-bit microprocessor bus, the last byte of an odd-sized packet is output as the lower byte (LSByte).

**Remark:** Buffer Length is valid only after an interrupt is generated for the bulk endpoint.

**Table 37: Buffer Length register: bit allocation**

Bit	15	14	13	12	11	10	9	8
Symbol	DATACOUNT[15:8]							
Reset	0	0	0	0	0	0	0	0
Bus reset	0	0	0	0	0	0	0	0
Access	R/W	R/W	R/W	R/W	R/W	R/W	R/W	R/W
Bit	7	6	5	4	3	2	1	0
Symbol	DATACOUNT[7:0]							
Reset	0	0	0	0	0	0	0	0
Bus reset	0	0	0	0	0	0	0	0
Access	R/W	R/W	R/W	R/W	R/W	R/W	R/W	R/W

**Table 38: Buffer Length register: bit description**

Bit	Symbol	Description
15 to 0	DATACOUNT[15:0]	Determines the current packet size of the indexed endpoint FIFO.

**9.3.5 Buffer Status register (address: 1Eh)**

This register is accessed using index. The endpoint index must first be set before accessing this register for the corresponding endpoint. It reflects the status of the double buffered endpoint FIFO. This register is valid only when the endpoint is configured to be a double buffer.

**Remark:** This register is not applicable to the control endpoint.

Table 39 shows the bit allocation of the Buffer Status register.

**Table 39: Buffer Status register: bit allocation**

Bit	7	6	5	4	3	2	1	0
Symbol	reserved						BUF1	BUF0
Reset	-	-	-	-	-	-	0	0
Bus reset	-	-	-	-	-	-	0	0
Access	-	-	-	-	-	-	R	R

**Table 40: Buffer Status register: bit description**

Bit	Symbol	Description
7 to 2	-	reserved
1 to 0	BUF[1:0]	<b>00</b> — The buffers are not filled. <b>01</b> — One of the buffers is filled. <b>10</b> — One of the buffers is filled. <b>11</b> — Both the buffers are filled.

**9.3.6 Endpoint MaxPacketSize register (address: 04h)**

This register determines the maximum packet size for all endpoints except control 0. The register contains 2 bytes, and the bit allocation is given in [Table 41](#).

Each time the register is written, the Buffer Length registers of all endpoints are reinitialized to the FFOSZ field value. Bits NTRANS control the number of transactions allowed in a single microframe (for high-speed isochronous and interrupt endpoints only).

**Table 41: Endpoint MaxPacketSize register: bit allocation**

Bit	15	14	13	12	11	10	9	8
Symbol	reserved			NTRANS[1:0]		FFOSZ[10:8]		
Reset	-	-	-	0	0	0	0	0
Bus reset	-	-	-	0	0	0	0	0
Access	R/W	R/W	R/W	R/W	R/W	R/W	R/W	R/W
Bit	7	6	5	4	3	2	1	0
Symbol	FFOSZ[7:0]							
Reset	0	0	0	0	0	0	0	0
Bus reset	0	0	0	0	0	0	0	0
Access	R/W	R/W	R/W	R/W	R/W	R/W	R/W	R/W

**Table 42: Endpoint MaxPacketSize register: bit description**

Bit	Symbol	Description
15 to 13	-	reserved
12 to 11	NTRANS[1:0]	<b>Number of Transactions.</b> HS mode only.  <b>00</b> — 1 packet per microframe <b>01</b> — 2 packets per microframe <b>10</b> — 3 packets per microframe <b>11</b> — reserved.  These bits are applicable only for isochronous or interrupt transactions.
10 to 0	FFOSZ[10:0]	<b>FIFO Size:</b> Sets the FIFO size, in bytes, for the indexed endpoint. Applies to both high-speed and full-speed operations (see <a href="#">Table 43</a> ).

**Table 43: Programmable FIFO size**

NTRANS[1:0]	FFOSZ[10:0]	Non-isochronous	Isochronous
0h	08h	8 bytes	-
0h	10h	16 bytes	-
0h	20h	32 bytes	-
0h	40h	64 bytes	-
0h	80h	128 bytes	-
0h	100h	256 bytes	-
0h	200h	512 bytes	-
2h	400h	-	3072 bytes

Each programmable FIFO can be independently configured via its Endpoint MaxPacketSize register (R/W: 04h), but the total physical size of all enabled endpoints (IN plus OUT) must not exceed 8192 bytes.

**9.3.7 Endpoint Type register (address: 08h)**

This register sets the endpoint type of the indexed endpoint: isochronous, bulk or interrupt. It also serves to enable the endpoint and configure it for double buffering. Automatic generation of an empty packet for a zero-length TX buffer can be disabled using bit NOEMPKT. The register contains 2 bytes, and the bit allocation is shown in [Table 44](#).

**Table 44: Endpoint Type register: bit allocation**

Bit	15	14	13	12	11	10	9	8
Symbol	reserved							
Reset	-	-	-	-	-	-	-	-
Bus reset	-	-	-	-	-	-	-	-
Access	R/W	R/W	R/W	R/W	R/W	R/W	R/W	R/W

Bit	7	6	5	4	3	2	1	0
Symbol		reserved		NOEMPKT	ENABLE	DBLBUF	ENDPTYP[1:0]	
Reset	-	-	-	0	0	0	0	0
Bus reset	-	-	-	0	0	0	0	0
Access	R/W	R/W	R/W	R/W	R/W	R/W	R/W	R/W

Table 45: Endpoint Type register: bit description

Bit	Symbol	Description
15 to 5	-	reserved
4	NOEMPKT	<b>No Empty Packet:</b> Logic 0 causes the ISP1582 to return a null length packet for the IN token after the DMA IN transfer is complete. For ATA mode or the IN DMA transfer, which does not require a null length packet after DMA completion, set to logic 1 to disable the generation of the null length packet.
3	ENABLE	<b>Endpoint Enable:</b> Logic 1 enables the FIFO of the indexed endpoint. The memory size is allocated as specified in the Endpoint MaxPacketSize register. Logic 0 disables the FIFO. <b>Remark:</b> 'Stall'ing a data endpoint will confuse the Data Toggle bit on the stalled endpoint because the internal logic picks up from where it has stalled. Therefore, the Data Toggle bit must be reset by disabling and reenabling the corresponding endpoint (by setting bit ENABLE to logic 0 or logic 1 in the Endpoint Type register) to reset the PID.
2	DBLBUF	<b>Double Buffering:</b> Logic 1 enables double buffering for the indexed endpoint. Logic 0 disables double buffering.
1 to 0	ENDPTYP[1:0]	<b>Endpoint Type:</b> These bits select the endpoint type as follows.  <b>00</b> — not used <b>01</b> — Isochronous <b>10</b> — Bulk <b>11</b> — Interrupt.

### 9.4 DMA registers

The Generic DMA (GDMA) transfer can be done by writing the proper opcode in the DMA Command register. The control bits are given in Table 46.

#### GDMA read/write (opcode = 00h/01h) for Generic DMA slave mode

Depending on the MODE[1:0] bit set in the DMA configuration register, either the DACK signal or the DIOR/DIOW signals strobe the data. These signals are driven by the external DMA controller.

GDMA (slave) mode can operate in either counter mode or EOT-only mode.

In counter mode, bit DIS\_XFER\_CNT in the DMA Configuration register must be set to logic 0. The DMA Transfer Counter register must be programmed before any DMA command is issued. The DMA transfer counter is set by writing from the LSByte to the MSByte (address: 34h to 37h). The DMA transfer count is internally updated only after the MSByte has been written. Once the DMA transfer is started, the transfer counter starts decrementing and on reaching 0, bit DMA\_XFER\_OK is set and an

interrupt is generated by the ISP1582. If the DMA master wishes to terminate the DMA transfer, it can issue an EOT signal to the ISP1582. This EOT signal overrides the transfer counter and can terminate the DMA transfer at any time.

In EOT-only mode, DIS\_XFER\_CNT has to be set to logic 1. Although the DMA transfer counter can still be programmed, it will not have any effect on the DMA transfer. The DMA transfer will start once the DMA command is issued. Any of the following three ways will terminate this DMA transfer:

- Detecting an external EOT
- Detecting an internal EOT (short packet on an OUT token)
- Resetting the DMA.

There are three interrupts programmable to differentiate the method of DMA termination: bits INT\_EOT, EXT\_EOT and DMA\_XFER\_OK in the DMA Interrupt Reason register. For details, see [Table 58](#).

**Table 46: Control bits for GDMA read/write (opcode = 00h/01h)**

Control bits	Description	Reference
<b>DMA Configuration register</b>		
MODE[1:0]	Determines the active read/write data strobe signals.	<a href="#">Table 52</a>
WIDTH	Selects the DMA bus width: 8 or 16 bits.	
DIS_XFER_CNT	Disables the use of the DMA Transfer Counter.	
<b>DMA Hardware register</b>		
EOT_POL	Selects the polarity of the EOT signal.	<a href="#">Table 54</a>
ENDIAN[1:0]	Determines whether the data is to be byte swapped or normal. Applicable only in 16-bit mode.	
ACK_POL, DREQ_POL, WRITE_POL, READ_POL	Select the polarity of the DMA handshake signals.	

**Remark:** The DMA bus defaults to three-state, until a DMA command is executed. All the other control signals are not three-state.

**9.4.1 DMA Command register (address: 30h)**

The DMA Command register is a 1-byte register (for bit allocation, see [Table 47](#)) that initiates all DMA transfer activity on the DMA controller. The register is write-only: reading it will return FFh.

**Remark:** The DMA bus will be in three-state until a DMA command is executed.

**Table 47: DMA Command register: bit allocation**

Bit	7	6	5	4	3	2	1	0
Symbol	DMA_CMD[7:0]							
Reset	1	1	1	1	1	1	1	1
Bus reset	1	1	1	1	1	1	1	1
Access	W	W	W	W	W	W	W	W

**Table 48: DMA Command register: bit description**

Bit	Symbol	Description
7 to 0	DMA_CMD[7:0]	DMA command code; see <a href="#">Table 49</a> .

**Table 49: DMA commands**

Code	Name	Description
00h	GDMA Read	<b>Generic DMA IN token transfer (slave mode only):</b> Data is transferred from the external DMA bus to the internal buffer. Strobe: DIOW by external DMA controller.
01h	GDMA Write	<b>Generic DMA OUT token transfer (slave mode only):</b> Data is transferred from the internal buffer to the external DMA bus. Strobe: DIOR by external DMA controller.
02h to 0Dh	-	reserved
0Eh	Validate Buffer	<b>Validate Buffer (for debugging only):</b> Request from the microcontroller to validate the endpoint buffer following a DMA to USB data transfer.
0Fh	Clear Buffer	<b>Clear Buffer:</b> Request from the microcontroller to clear the endpoint buffer after a USB to DMA data transfer.
10h	-	reserved
11h	Reset DMA	<b>Reset DMA:</b> Initializes the DMA core to its power-on reset state. <b>Remark:</b> When the DMA core is reset during the Reset DMA command, the DREQ, DACK, DIOW and DIOR handshake pins will be temporarily asserted. This can confuse the external DMA controller. To prevent this, start the external DMA controller <b>only after</b> the DMA reset.
12h	-	reserved
13h	GDMA Stop	<b>GDMA stop:</b> This command stops the GDMA data transfer. Any data in the OUT endpoint that is not transferred by the DMA will remain in the buffer. The FIFO data for the IN endpoint will be written to the endpoint buffer. An interrupt bit will be set to indicate the completion of the DMA Stop command.
14h to FFh	-	reserved

**9.4.2 DMA Transfer Counter register (address: 34h)**

This 4-byte register sets up the total byte count for a DMA transfer (DMACR). It indicates the remaining number of bytes left for transfer. The bit allocation is given in [Table 50](#).

**For IN endpoint** — As there is a FIFO in the ISP1582 DMA controller, some data may remain in the FIFO during the DMA transfer. The maximum FIFO size is 8 bytes, and the maximum delay time for the data to be shifted to endpoint buffer is 60 ns.

**For OUT endpoint** — Data will not be cleared for the endpoint buffer until all the data has been read from the DMA FIFO.

If the DMA counter is disabled in the DMA transfer, it will still decrement and rollover when it reaches zero.

**Table 50: DMA Transfer Counter register: bit allocation**

Bit	31	30	29	28	27	26	25	24
Symbol	DMACR4 = DMACR[31:24]							
Reset	0	0	0	0	0	0	0	0
Bus reset	0	0	0	0	0	0	0	0
Access	R/W	R/W	R/W	R/W	R/W	R/W	R/W	R/W

Bit	23	22	21	20	19	18	17	16
Symbol	DMACR3 = DMACR[23:16]							
Reset	0	0	0	0	0	0	0	0
Bus reset	0	0	0	0	0	0	0	0
Access	R/W	R/W	R/W	R/W	R/W	R/W	R/W	R/W
Bit	15	14	13	12	11	10	9	8
Symbol	DMACR2 = DMACR[15:8]							
Reset	0	0	0	0	0	0	0	0
Bus reset	0	0	0	0	0	0	0	0
Access	R/W	R/W	R/W	R/W	R/W	R/W	R/W	R/W
Bit	7	6	5	4	3	2	1	0
Symbol	DMACR1 = DMACR[7:0]							
Reset	0	0	0	0	0	0	0	0
Bus reset	0	0	0	0	0	0	0	0
Access	R/W	R/W	R/W	R/W	R/W	R/W	R/W	R/W

Table 51: DMA Transfer Counter register: bit description

Bit	Symbol	Description
31 to 24	DMACR4, DMACR[31:24]	DMA transfer counter byte 4 (MSB)
23 to 16	DMACR3, DMACR[23:16]	DMA transfer counter byte 3
15 to 8	DMACR2, DMACR[15:8]	DMA transfer counter byte 2
7 to 0	DMACR1, DMACR[7:0]	DMA transfer counter byte 1 (LSB)

9.4.3 DMA Configuration register (address: 38h)

This register defines the DMA configuration for GDMA mode. The DMA Configuration register consists of 2 bytes. The bit allocation is given in Table 52.

Table 52: DMA Configuration register: bit allocation

Bit	15	14	13	12	11	10	9	8
Symbol	reserved							
Reset	0	0	0	0	0	0	0	0
Bus Reset	0	0	0	0	0	0	0	0
Access	R/W	R/W	R/W	R/W	R/W	R/W	R/W	R/W
Bit	7	6	5	4	3	2	1	0
Symbol	DIS_XFER_CNT	reserved			MODE[1:0]		reserved	WIDTH
Reset	0	0	0	0	0	0	0	1
Bus Reset	0	0	0	0	0	0	0	1
Access	R/W	R/W	R/W	R/W	R/W	R/W	R/W	R/W

**Table 53: DMA Configuration register: bit description<sup>[1]</sup>**

Bit	Symbol	Description
15 to 8	-	reserved
7	DIS_XFER_CNT	Logic 1 disables the DMA Transfer Counter (see Table 50). The transfer counter can be disabled only in GDMA (slave) mode.
6 to 4	-	reserved
3 to 2	MODE[1:0]	These bits only affect the GDMA slave handshake signals.  <b>00</b> — DIOW slave strobos data from the DMA bus into the ISP1582; DIOR slave puts data from the ISP1582 on the DMA bus <b>01</b> — DACK slave strobos data from the DMA bus into the ISP1582; DIOR slave puts data from the ISP1582 on the DMA bus <b>10</b> — DACK slave strobos data from the DMA bus into the ISP1582 and also puts data from the ISP1582 on the DMA bus. (This mode is applicable only to the 16-bit DMA; this mode cannot be used for the 8-bit DMA.) <b>11</b> — reserved.
1	-	reserved
0	WIDTH	This bit selects the DMA bus width for the GDMA slave.  <b>0</b> — 8-bit data bus <b>1</b> — 16-bit data bus.

[1] The DREQ pin will only be driven only after you perform a write access to the DMA Configuration register (that is, after you have configured the DMA Configuration register).

**9.4.4 DMA Hardware register (address: 3Ch)**

The DMA Hardware register consists of 1 byte. The bit allocation is shown in Table 54.

This register determines the polarity of the bus control signals (EOT, DACK, DREQ, DIOR and DIOW) and DMA mode (master or slave). It also controls whether the upper and lower parts of the data bus are swapped (bits ENDIAN[1:0]) for GDMA (slave) mode.

**Table 54: DMA Hardware register: bit allocation**

Bit	7	6	5	4	3	2	1	0
Symbol	ENDIAN[1:0]		EOT_POL	reserved	ACK_POL	DREQ_POL	WRITE_POL	READ_POL
Reset	0	0	0	0	0	1	0	0
Bus reset	0	0	0	0	0	1	0	0
Access	R/W	R/W	R/W	R/W	R/W	R/W	R/W	R/W

Table 55: DMA Hardware register: bit description

Bit	Symbol	Description
7 to 6	ENDIAN[1:0]	<p>These bits determine whether the data bus is swapped between the internal RAM and the DMA bus. This only applies for GDMA (slave) mode.</p> <p><b>00</b> — Normal data representation 16-bit bus: MSB on DATA[15:8], LSB on DATA[7:0]</p> <p><b>01</b> — Swapped data representation 16-bit bus: MSB on DATA[7:0], LSB on DATA[15:8]</p> <p><b>10</b> — reserved</p> <p><b>11</b> — reserved.</p> <p><b>Remark:</b> While operating with the 8-bit data bus, bits ENDIAN[1:0] should be always set to logic 00.</p>
5	EOT_POL	<p>Selects the polarity of the End-Of-Transfer input; used in GDMA (slave) mode only.</p> <p><b>0</b> — EOT is active LOW</p> <p><b>1</b> — EOT is active HIGH.</p>
4	-	reserved; must be set to logic 0.
3	ACK_POL	<p>Selects the DMA acknowledgment polarity.</p> <p><b>0</b> — DACK is active LOW</p> <p><b>1</b> — DACK is active HIGH.</p>
2	DREQ_POL	<p>Selects the DMA request polarity.</p> <p><b>0</b> — DREQ is active LOW</p> <p><b>1</b> — DREQ is active HIGH.</p>
1	WRITE_POL	<p>Selects the DIOW strobe polarity.</p> <p><b>0</b> — DIOW is active LOW</p> <p><b>1</b> — DIOW is active HIGH.</p>
0	READ_POL	<p>Selects the DIOR strobe polarity.</p> <p><b>0</b> — DIOR is active LOW</p> <p><b>1</b> — DIOR is active HIGH.</p>

#### 9.4.5 DMA Interrupt Reason register (address: 50h)

This 2-byte register shows the source(s) of DMA interrupt. Each bit is refreshed after a DMA command has been executed. An interrupt source is cleared by writing logic 1 to the corresponding bit. When reading, AND the value of the bits in this register with the value of the corresponding bits in the DMA Interrupt Enable register.

The bit allocation is given in [Table 56](#).

**Table 56: DMA Interrupt Reason register: bit allocation**

Bit	15	14	13	12	11	10	9	8
Symbol	TEST3	reserved		GDMA_STOP	EXT_EOT	INT_EOT	reserved	DMA_XFER_OK
Reset	-	-	-	0	0	0	-	0
Bus reset	-	-	-	0	0	0	-	0
Access	R	R	R	R/W	R/W	R/W	R/W	R/W
Bit	7	6	5	4	3	2	1	0
Symbol	reserved							
Reset	-	-	-	-	-	-	-	-
Bus reset	-	-	-	-	-	-	-	-
Access	R/W	R/W	R/W	R/W	R/W	R/W	R/W	R/W

**Table 57: DMA Interrupt Reason register: bit description**

Bit	Symbol	Description
15	TEST3	This bit is set when the DMA transfer for a packet (OUT transfer) terminates before the whole packet has been transferred. This bit is a status bit, and the corresponding mask bit of this register is always logic 0. Writing any value other than logic 0 has no effect.
14 to 13	-	reserved
12	GDMA_STOP	When the GDMA_STOP command is issued to the DMA Command registers, it means the DMA transfer has successfully terminated.
11	EXT_EOT	Logic 1 indicates that an external EOT is detected. This is applicable only in GDMA (slave) mode.
10	INT_EOT	Logic 1 indicates that an internal EOT is detected; see <a href="#">Table 58</a> .
9	-	reserved
8	DMA_XFER_OK	Logic 1 indicates that the DMA transfer has been completed (DMA Transfer Counter has become zero). This bit is only used in GDMA (slave) mode.
7 to 0	-	reserved

**Table 58: Internal EOT-functional relation with bit DMA\_XFER\_OK**

INT_EOT	DMA_XFER_OK	Description
1	0	During the DMA transfer, there is a premature termination with short packet.
1	1	DMA transfer is completed with short packet and the DMA transfer counter has reached 0.
0	1	DMA transfer is completed without any short packet and the DMA transfer counter has reached 0.

**Table 59** shows the status of the bits in the DMA Interrupt Reason register when the corresponding bits in the Interrupt register is set.

**Table 59: Status of the bits in the DMA Interrupt Reason register<sup>[1][2]</sup>**

Status	EXT_EOT	INT_EOT	DMA_XFER_OK	
			Counter enabled	Counter disabled
IN full	1	0	1	0
IN short	1	0	1	0
OUT full	1	0	1	0
OUT short	1	1 <sup>[3]</sup>	1	0

- [1] 1 indicates that the bit is set and 0 indicates that the bit is not set. A bit is set when the corresponding EOT condition is met. For example; EXT\_EOT is set if external EOT conditions are met (pin EOT active), regardless of other EOT conditions. If multiple EOT conditions are met, the corresponding interrupt bits are set.
- [2] If both EXT\_EOT and DMA\_XFER\_OK conditions are met in DMA for an IN endpoint, the EXT\_EOT interrupt is not set.
- [3] The value of INT\_EOT may not be accurate if an external or internal transfer counter is programmed with a value that is lower than the transfer that the host requests. To terminate an OUT transfer with INT\_EOT, the external or internal DMA counter should be programmed as a multiple of the full-packet length of the DMA endpoint. When a short packet is successfully transferred by DMA, INT\_EOT is set.

**9.4.6 DMA Interrupt Enable register (address: 54h)**

This 2-byte register controls the interrupt generation of the source bits in the DMA Interrupt Reason register. The bit allocation is given in Table 60. The bit description is given in Table 57.

Logic 1 enables the interrupt generation. After a bus reset, interrupt generation is disabled, with the values turning to logic 0.

**Table 60: DMA Interrupt Enable register: bit allocation**

Bit	15	14	13	12	11	10	9	8
Symbol	TEST4	reserved		IE_GDMA_STOP	IE_EXT_EOT	IE_INT_EOT	reserved	IE_DMA_XFER_OK
Reset	-	-	-	0	0	0	0	0
Bus reset	-	-	-	0	0	0	0	0
Access	R	-	-	R/W	R/W	R/W	R/W	R/W
Bit	7	6	5	4	3	2	1	0
Symbol	reserved							
Reset	0	0	0	0	0	0	0	0
Bus reset	0	0	0	0	0	0	0	0
Access	R/W	R/W	R/W	R/W	R/W	R/W	R/W	R/W

**9.4.7 DMA Endpoint register (address: 58h)**

This 1-byte register selects a USB endpoint FIFO as a source or destination for DMA transfers. The bit allocation is given in Table 61.

**Table 61: DMA Endpoint register: bit allocation**

Bit	7	6	5	4	3	2	1	0
Symbol	reserved				EPIDX[2:0]			DMADIR
Reset	-	-	-	-	0	0	0	0
Bus reset	-	-	-	-	0	0	0	0
Access	-	-	-	-	R/W	R/W	R/W	R/W

**Table 62: DMA Endpoint register: bit description**

Bit	Symbol	Description
7 to 4	-	reserved
3 to 1	EPIDX[2:0]	selects the indicated endpoint for DMA access
0	DMADIR	<b>0</b> — Selects the RX/OUT FIFO for DMA read transfers <b>1</b> — Selects the TX/IN FIFO for DMA write transfers.

The DMA Endpoint register must not reference the endpoint that is indexed by the Endpoint Index register (2Ch) at any time. Doing so would result in data corruption. Therefore, if the DMA Endpoint register is unused, point it to an unused endpoint. If the DMA Endpoint register, however, is pointed to an active endpoint, the firmware must not reference the same endpoint on the Endpoint Index register.

**9.4.8 DMA Burst Counter register (address: 64h)**

Table 63 shows the bit allocation of the register.

**Table 63: DMA Burst Counter register: bit allocation**

Bit	15	14	13	12	11	10	9	8
Symbol	reserved			BURSTCOUNTER[12:8]				
Reset	-	-	-	0	0	0	0	0
Bus reset	-	-	-	0	0	0	0	0
Access	-	-	-	R/W	R/W	R/W	R/W	R/W
Bit	7	6	5	4	3	2	1	0
Symbol	BURSTCOUNTER[7:0]							
Reset	0	0	0	0	0	0	1	0
Bus reset	0	0	0	0	0	0	1	0
Access	R/W	R/W	R/W	R/W	R/W	R/W	R/W	R/W

**Table 64: DMA Burst Counter register: bit description**

Bit	Symbol	Description
15 to 13	-	reserved
12 to 0	BURSTCOUNTER[12:0]	This register defines the burst length. The counter must be programmed to be a multiple of two in 16-bit mode. The value of the burst counter should be programmed such that the buffer counter is a factor of the burst counter.  <b>For IN endpoint</b> — When the burst counter equals 2, in GDMA mode, DREQ will drop at every DMA read or write cycle.

**9.5 General registers**

**9.5.1 Interrupt register (address: 18h)**

The Interrupt register consists of 4 bytes. The bit allocation is given in Table 65.

When a bit is set in the Interrupt register, it indicates that the hardware condition for an interrupt has occurred. When the Interrupt register content is nonzero, the INT output will be asserted corresponding to the Interrupt Enable register. On detecting the interrupt, the external microprocessor must read the Interrupt register and mask it with the corresponding bits in the Interrupt Enable register to determine the source of the interrupt.

Each endpoint buffer has a dedicated interrupt bit (EPnTX, EPnRX). In addition, various bus states can generate an interrupt: resume, suspend, pseudo SOF, SOF and bus reset. The DMA controller only has one interrupt bit: the source for a DMA interrupt is shown in the DMA Interrupt Reason register.

Each interrupt bit can be individually cleared by writing logic 1. The DMA Interrupt bit can be cleared by writing logic 1 to the related interrupt source bit in the DMA Interrupt Reason register and writing logic 1 to the DMA bit of the Interrupt register.

**Table 65: Interrupt register: bit allocation**

Bit	31	30	29	28	27	26	25	24
Symbol	reserved						EP7TX	EP7RX
Reset	-	-	-	-	-	0	0	0
Bus reset	-	-	-	-	-	0	0	0
Access	-	-	-	-	-	R/W	R/W	R/W
Bit	23	22	21	20	19	18	17	16
Symbol	EP6TX	EP6RX	EP5TX	EP5RX	EP4TX	EP4RX	EP3TX	EP3RX
Reset	0	0	0	0	0	0	0	0
Bus reset	0	0	0	0	0	0	0	0
Access	R/W	R/W	R/W	R/W	R/W	R/W	R/W	R/W
Bit	15	14	13	12	11	10	9	8
Symbol	EP2TX	EP2RX	EP1TX	EP1RX	EP0TX	EP0RX	reserved	EP0SETUP
Reset	0	0	0	0	0	0	-	0
Bus reset	0	0	0	0	0	0	-	0
Access	R/W	R/W	R/W	R/W	R/W	R/W	-	R/W
Bit	7	6	5	4	3	2	1	0
Symbol	VBUS	DMA	HS_STAT	RESUME	SUSP	PSOF	SOF	BRESET
Reset	0	0	0	0	0	0	0	0
Bus reset	0	0	0	0	0	0	0	unchanged
Access	R/W	R/W	R/W	R/W	R/W	R/W	R/W	R/W

**Table 66: Interrupt register: bit description**

Bit	Symbol	Description
31 to 26	-	reserved
25	EP7TX	Logic 1 indicates the endpoint 7 TX buffer as interrupt source.
24	EP7RX	Logic 1 indicates the endpoint 7 RX buffer as interrupt source.
23	EP6TX	Logic 1 indicates the endpoint 6 TX buffer as interrupt source.
22	EP6RX	Logic 1 indicates the endpoint 6 RX buffer as interrupt source.
21	EP5TX	Logic 1 indicates the endpoint 5 TX buffer as interrupt source.

**Table 66: Interrupt register: bit description...continued**

Bit	Symbol	Description
20	EP5RX	Logic 1 indicates the endpoint 5 RX buffer as interrupt source.
19	EP4TX	Logic 1 indicates the endpoint 4 TX buffer as interrupt source.
18	EP4RX	Logic 1 indicates the endpoint 4 RX buffer as interrupt source.
17	EP3TX	Logic 1 indicates the endpoint 3 TX buffer as interrupt source.
16	EP3RX	Logic 1 indicates the endpoint 3 RX buffer as interrupt source.
15	EP2TX	Logic 1 indicates the endpoint 2 TX buffer as interrupt source.
14	EP2RX	Logic 1 indicates the endpoint 2 RX buffer as interrupt source.
13	EP1TX	Logic 1 indicates the endpoint 1 TX buffer as interrupt source.
12	EP1RX	Logic 1 indicates the endpoint 1 RX buffer as interrupt source.
11	EP0TX	Logic 1 indicates the endpoint 0 data TX buffer as interrupt source.
10	EP0RX	Logic 1 indicates the endpoint 0 data RX buffer as interrupt source.
9	-	reserved
8	EP0SETUP	Logic 1 indicates that a SETUP token was received on endpoint 0.
7	VBUS	Logic 1 indicates V <sub>BUS</sub> is turned on.
6	DMA	<b>DMA status:</b> Logic 1 indicates a change in the DMA Status register.
5	HS_STAT	<b>High speed status:</b> Logic 1 indicates a change from full-speed to high-speed mode (HS connection). This bit is not set, when the system goes into full-speed suspend.
4	RESUME	<b>Resume status:</b> Logic 1 indicates that a status change from suspend to resume (active) was detected.
3	SUSP	<b>Suspend status:</b> Logic 1 indicates that a status change from active to suspend was detected on the bus.
2	PSOF	<b>Pseudo SOF interrupt:</b> Logic 1 indicates that a pseudo SOF or $\mu$ SOF was received. Pseudo SOF is an internally generated clock signal (full-speed: 1 ms period, high-speed: 125 $\mu$ s period) synchronized to the USB bus SOF or $\mu$ SOF.
1	SOF	<b>SOF interrupt:</b> Logic 1 indicates that a SOF or $\mu$ SOF was received.
0	BRESET	<b>Bus reset:</b> Logic 1 indicates that a USB bus reset was detected. When bit OTG in the OTG register is set, BRESET will not be set, instead, this interrupt bit will report SE0 on DP and DM for 2 ms.

**9.5.2 Chip ID register (address: 70h)**

This read-only register contains the chip identification and the hardware version numbers. The firmware should check this information to determine the functions and features supported. The register contains 3 bytes, and the bit allocation is shown in [Table 67](#).

**Table 67: Chip ID register: bit allocation**

Bit	23	22	21	20	19	18	17	16
Symbol	CHIPID[15:8]							
Reset	0	0	0	1	0	1	0	1
Bus reset	0	0	0	1	0	1	0	1
Access	R	R	R	R	R	R	R	R

Bit	15	14	13	12	11	10	9	8
Symbol	CHIPID[7:0]							
Reset	1	0	0	0	0	0	1	0
Bus reset	1	0	0	0	0	0	1	0
Access	R	R	R	R	R	R	R	R
Bit	7	6	5	4	3	2	1	0
Symbol	VERSION[7:0]							
Reset	0	0	1	1	0	0	0	0
Bus reset	0	0	1	1	0	0	0	0
Access	R	R	R	R	R	R	R	R

Table 68: Chip ID register: bit description

Bit	Symbol	Description
23 to 16	CHIPID[15:8]	chip ID: lower byte (15h)
15 to 8	CHIPID[7:0]	chip ID: upper byte (82h)
7 to 0	VERSION[7:0]	version number (30h)

### 9.5.3 Frame Number register (address: 74h)

This read-only register contains the frame number of the last successfully received Start-Of-Frame (SOF). The register contains 2 bytes, and the bit allocation is given in Table 69. In case of 8-bit access, the register content is returned lower byte first.

Table 69: Frame Number register: bit allocation

Bit	15	14	13	12	11	10	9	8
Symbol	reserved		MICROSOF[2:0]			SOFR[10:8]		
Power Reset	-	-	0	0	0	0	0	0
Bus Reset	-	-	0	0	0	0	0	0
Access	R	R	R	R	R	R	R	R
Bit	7	6	5	4	3	2	1	0
Symbol	SOFR[7:0]							
Power Reset	0	0	0	0	0	0	0	0
Bus Reset	0	0	0	0	0	0	0	0
Access	R	R	R	R	R	R	R	R

Table 70: Frame Number register: bit description

Bit	Symbol	Description
15 to 14	-	reserved
13 to 11	MICROSOF[2:0]	microframe number
10 to 0	SOFR[10:0]	frame number

### 9.5.4 Scratch register (address: 78h)

This 16-bit register can be used by the firmware to save and restore information. For example, the device status before it enters the suspend state. The bit allocation is given in Table 71.

**Table 71: Scratch register: bit allocation**

Bit	15	14	13	12	11	10	9	8
Symbol	SFIRH[7:0]							
Reset	0	0	0	0	0	0	0	0
Bus reset	0	0	0	0	0	0	0	0
Access	R/W	R/W	R/W	R/W	R/W	R/W	R/W	R/W
Bit	7	6	5	4	3	2	1	0
Symbol	SFIRL[7:0]							
Reset	0	0	0	0	0	0	0	0
Bus reset	0	0	0	0	0	0	0	0
Access	R/W	R/W	R/W	R/W	R/W	R/W	R/W	R/W

**Table 72: Scratch register: bit description**

Bit	Symbol	Description
15 to 8	SFIRH[7:0]	Scratch firmware information register (higher byte)
7 to 0	SFIRL[7:0]	Scratch firmware information register (lower byte)

**9.5.5 Unlock Device register (address: 7Ch)**

To protect the registers from getting corrupted when the ISP1582 goes into suspend, the write operation is disabled if bit PWRON in the Mode register is set to logic 0. In this case, when the chip resumes, the Unlock Device command must be first issued to this register before attempting to write to the rest of the registers. This is done by writing unlock code (AA37h) to this register.

The bit allocation of the Unlock Device register is given in [Table 73](#).

**Table 73: Unlock Device register: bit allocation**

Bit	15	14	13	12	11	10	9	8
Symbol	ULCODE[15:8] = AAh							
Reset	not applicable							
Bus reset	not applicable							
Access	W	W	W	W	W	W	W	W
Bit	7	6	5	4	3	2	1	0
Symbol	ULCODE[7:0] = 37h							
Reset	not applicable							
Bus reset	not applicable							
Access	W	W	W	W	W	W	W	W

**Table 74: Unlock Device register: bit description**

Bit	Symbol	Description
15 to 0	ULCODE[15:0]	Writing data AA37h unlocks the internal registers and FIFOs for writing, following a resume.

When bit PWRON in the Mode register is logic 1, the chip is powered. In such a case, you do not need to issue the Unlock command because the microprocessor is powered and therefore, the RD\_N, WR\_N and CS\_N signals maintain their states.

When bit PWRON is logic 0, the RD\_N, WR\_N and CS\_N signals are floating because the microprocessor is not powered. To protect the ISP1582 registers from being corrupted during suspend, register write is locked when the chip goes into suspend. Therefore, you need to issue the Unlock command to unlock the ISP1582 registers.

**9.5.6 Test Mode register (address: 84h)**

This 1-byte register allows the firmware to set pins DP and DM to predetermined states for testing purposes. The bit allocation is given in Table 75.

**Remark:** Only one bit can be set to logic 1 at a time. This must be implemented for the Hi-Speed USB logo compliance testing.

**Table 75: Test Mode register: bit allocation**

Bit	7	6	5	4	3	2	1	0
Symbol	FORCEHS	reserved		FORCEFS	PRBS	KSTATE	JSTATE	SE0_NAK
Reset	0	-	-	0	0	0	0	0
Bus reset	0	-	-	0	0	0	0	0
Access	R/W	R/W	R/W	R/W	R/W	R/W	R/W	R/W

**Table 76: Test Mode register: bit description**

Bit	Symbol	Description
7	FORCEHS	logic 1 <sup>[1]</sup> forces the hardware to high-speed mode only and disables the chirp detection logic.
6 to 5	-	reserved.
4	FORCEFS	logic 1 <sup>[1]</sup> forces the physical layer to full-speed mode only and disables the chirp detection logic.
3	PRBS	logic 1 <sup>[2]</sup> sets pins DP and DM to toggle in a predetermined random pattern.
2	KSTATE	writing logic 1 <sup>[2]</sup> sets pins DP and DM to the K state.
1	JSTATE	writing logic 1 <sup>[2]</sup> sets pins DP and DM to the J state.
0	SE0_NAK	writing logic 1 <sup>[2]</sup> sets pins DP and DM to a high-speed quiescent state. The device only responds to a valid high-speed IN token with a NAK.

[1] Either FORCEHS or FORCEFS should be set at a time.

[2] Of the four bits (PRBS, KSTATE, JSTATE and SE0\_NAK), only one bit should be set at a time.

## 10. Limiting values

**Table 77: Absolute maximum ratings**

In accordance with the Absolute Maximum Rating System (IEC 60134).

Symbol	Parameter	Conditions	Min	Max	Unit
$V_{CC}$	supply voltage		-0.5	+4.6	V
$V_{CC(I/O)}$	I/O pad supply voltage		-0.5	+4.6	V
$V_I$	input voltage		[1] -0.5	$V_{CC} + 0.5$	V
$I_{lu}$	latch-up current	$V_I < 0$ or $V_I > V_{CC}$	-	100	mA
$V_{esd}$	electrostatic discharge voltage	$I_{LI} < 1 \mu A$	-2000	+2000	V
$T_{stg}$	storage temperature		-40	+125	°C

[1] The maximum value for 5 V tolerant pins is 6 V.

## 11. Recommended operating conditions

**Table 78: Recommended operating conditions**

Symbol	Parameter	Conditions	Min	Max	Unit
$V_{CC}$	supply voltage		3.0	3.6	V
$V_{CC(I/O)}$	I/O pad supply voltage		$V_{CC}$	$V_{CC}$	V
$V_I$	input voltage range	$V_{CC} = 3.3 V$	0	5.5	V
$V_{I(A/I/O)}$	input voltage on analog I/O pins DP and DM		0	3.6	V
$V_{O(pu)}$	open-drain output pull-up voltage		0	$V_{CC}$	V
$T_{amb}$	ambient temperature		-40	+85	°C

## 12. Static characteristics

**Table 79: Static characteristics; supply pins**

$V_{CC} = 3.3\text{ V} \pm 0.3\text{ V}$ ;  $V_{GND} = 0\text{ V}$ ;  $T_{amb} = -40\text{ }^{\circ}\text{C}$  to  $+85\text{ }^{\circ}\text{C}$ ; typical values at  $T_{amb} = 25\text{ }^{\circ}\text{C}$ ; unless otherwise specified.

Symbol	Parameter	Conditions	Min	Typ	Max	Unit
<b>Supply voltage</b>						
$V_{CC}$	supply voltage		3.0	3.3	3.6	V
$I_{CC}$	operating supply current	$V_{CC} = 3.3\text{ V}$				
		high-speed	-	45	60	mA
		full-speed	-	17	25	mA
$I_{CC(susp)}$	suspend supply current	$V_{CC} = 3.3\text{ V}$	-	160	-	$\mu\text{A}$
<b>I/O pad supply voltage</b>						
$V_{CC(I/O)}$	I/O pad supply voltage		$V_{CC}$	$V_{CC}$	$V_{CC}$	V
$I_{CC(I/O)}$	operating supply current	$V_{CC(I/O)} = 3.3\text{ V}$				
		high-speed	-	430	500	$\mu\text{A}$
		full-speed	-	180	120	$\mu\text{A}$
$I_{CC(I/O)(susp)}$	suspend supply current	$V_{CC(I/O)} = 3.3\text{ V}$	-	5	10	$\mu\text{A}$
<b>Regulated supply voltage</b>						
$V_{CC(1V8)}$	regulated supply voltage	with voltage converter	1.65	1.8	1.95	V

**Table 80: Static characteristics: digital pins**

$V_{CC(I/O)} = V_{CC}$ ;  $V_{GND} = 0\text{ V}$ ;  $T_{amb} = -40\text{ }^{\circ}\text{C}$  to  $+85\text{ }^{\circ}\text{C}$ ; unless otherwise specified.

Symbol	Parameter	Conditions	Min	Typ	Max	Unit
<b>Input levels</b>						
$V_{IL}$	LOW-level input voltage		-	-	$0.3V_{CC(I/O)}$	V
$V_{IH}$	HIGH-level input voltage		$0.7V_{CC(I/O)}$	-	-	V
<b>Output levels</b>						
$V_{OL}$	LOW-level output voltage	$I_{OL} = \text{rated drive}$	-	-	$0.15V_{CC(I/O)}$	V
$V_{OH}$	HIGH-level output voltage	$I_{OH} = \text{rated drive}$	$0.8V_{CC(I/O)}$	-	-	V
<b>Leakage current</b>						
$I_{LI}$	input leakage current		[1] -5	-	+5	$\mu\text{A}$

[1] This value is applicable to transistor input only. The value will be different if internal pull-up or pull-down resistors are used.

**Table 81: Static characteristics: OTG detection**

$V_{CC(I/O)} = V_{CC}$ ;  $V_{GND} = 0\text{ V}$ ;  $T_{amb} = -40\text{ }^{\circ}\text{C}$  to  $+85\text{ }^{\circ}\text{C}$ ; unless otherwise specified.

Symbol	Parameter	Conditions	Min	Typ	Max	Unit
<b>Charging and discharging resistor</b>						
$R_{PD}$	discharging resistor		684.8	843.5	1032	$\Omega$
$R_{PU}$	charging resistor		551.9	666.7	780.6	$\Omega$
<b>Comparator levels</b>						
$V_{BVALID}$	$V_{BUS}$ valid detection	$V_{CC(I/O)} = 3.3\text{ V} \pm 0.3\text{ V}$	2.0	-	4.0	V
$V_{SESEND}$	$V_{BUS}$ B-session end detection	$V_{CC(I/O)} = 3.3\text{ V} \pm 0.3\text{ V}$	0.2	-	0.8	V

**Table 82: Static characteristics: analog I/O pins DP and DM<sup>[1]</sup>**

$V_{CC} = 3.3\text{ V} \pm 0.3\text{ V}$ ;  $V_{GND} = 0\text{ V}$ ;  $T_{amb} = -40\text{ }^{\circ}\text{C}$  to  $+85\text{ }^{\circ}\text{C}$ ; unless otherwise specified.

Symbol	Parameter	Conditions	Min	Typ	Max	Unit
<b>Input levels</b>						
$V_{DI}$	differential input sensitivity	$ V_{I(DP)} - V_{I(DM)} $	0.2	-	-	V
$V_{CM}$	differential common mode voltage	includes $V_{DI}$ range	0.8	-	2.5	V
$V_{SE}$	single-ended receiver threshold		0.8	-	2.0	V
$V_{IL}$	LOW-level input voltage		-	-	0.8	V
$V_{IH}$	HIGH-level input voltage		2.0	-	-	V
<b>Schmitt-trigger inputs</b>						
$V_{th(LH)}$	positive-going threshold voltage		1.4	-	1.9	V
$V_{th(HL)}$	negative-going threshold voltage		0.9	-	1.5	V
$V_{hys}$	hysteresis voltage		0.4	-	0.7	V
<b>Output levels</b>						
$V_{OL}$	LOW-level output voltage	$R_L = 1.5\text{ k}\Omega$ to $3.6\text{ V}$	-	-	0.4	V
$V_{OH}$	HIGH-level output voltage	$R_L = 15\text{ k}\Omega$ to GND	2.8	-	3.6	V
<b>Leakage current</b>						
$I_{LZ}$	OFF-state leakage current	$0 < V_I < 3.3\text{ V}$	-10	-	+10	$\mu\text{A}$
<b>Capacitance</b>						
$C_{IN}$	transceiver capacitance	pin to GND	-	-	10	pF
<b>Resistance</b>						
$Z_{DRV}$	driver output impedance	steady-state drive	40.5	-	49.5	$\Omega$
$Z_{INP}$	input impedance		10	-	-	M $\Omega$

[1] Pin DP is the USB positive data pin and pin DM is the USB negative data pin.

### 13. Dynamic characteristics

**Table 83: Dynamic characteristics**

$V_{CC} = 3.3\text{ V} \pm 0.3\text{ V}$ ;  $V_{GND} = 0\text{ V}$ ;  $T_{amb} = -40\text{ }^{\circ}\text{C}$  to  $+85\text{ }^{\circ}\text{C}$ ; unless otherwise specified.

Symbol	Parameter	Conditions	Min	Typ	Max	Unit
<b>Reset</b>						
$t_{W(RES\#)}$	pulse width on pin RESET_N	crystal oscillator running	500	-	-	$\mu\text{s}$
<b>Crystal oscillator</b>						
$f_{XTAL}$	crystal frequency		-	12	-	MHz
$R_S$	series resistance		-	-	100	$\Omega$
$C_L$	load capacitance		-	18	-	pF
<b>External clock input</b>						
$V_{IN}$	input voltage		1.65	1.8	1.95	V
$t_J$	external clock jitter		-	-	500	ps
$\delta$	clock duty cycle		45	50	55	%
$t_r, t_f$	rise time and fall time		-	-	3	ns

**Table 84: Dynamic characteristics: analog I/O pins DP and DM**

$V_{CC} = 3.3 V \pm 0.3 V$ ;  $V_{GND} = 0 V$ ;  $T_{amb} = -40^{\circ}C$  to  $+85^{\circ}C$ ;  $C_L = 50 pF$ ;  $R_{PU} = 1.5 k\Omega$  on DP to  $V_{TERM}$ ; test circuit of [Figure 25](#); unless otherwise specified.

Symbol	Parameter	Conditions	Min	Typ	Max	Unit
<b>Driver characteristics</b>						
<b>Full-speed mode</b>						
$t_{FR}$	rise time	$C_L = 50 pF$ ; 10 % to 90 % of $ V_{OH} - V_{OL} $	4	-	20	ns
$t_{FF}$	fall time	$C_L = 50 pF$ ; 90 % to 10 % of $ V_{OH} - V_{OL} $	4	-	20	ns
FRFM	differential rise time and fall time matching ( $t_{FR}/t_{FF}$ )		[1] 90	-	111.11	%
$V_{CRS}$	output signal crossover voltage		[1][2] 1.3	-	2.0	V
<b>High-speed mode</b>						
$t_{HSR}$	high-speed differential rise time	with captive cable	500	-	-	ps
$t_{HSF}$	high-speed differential fall time	with captive cable	500	-	-	ps
<b>Data source timing</b>						
<b>Full-speed mode</b>						
$t_{FEOPT}$	source EOP width	see <a href="#">Figure 16</a>	[2] 160	-	175	ns
$t_{FDEOP}$	source differential data-to-EOP transition skew	see <a href="#">Figure 16</a>	[2] -2	-	+5	ns
<b>Receiver timing</b>						
<b>Full-speed mode</b>						
$t_{JR1}$	receiver data jitter tolerance to next transition	see <a href="#">Figure 17</a>	[2] -18.5	-	+18.5	ns
$t_{JR2}$	receiver data jitter tolerance for paired transitions	see <a href="#">Figure 17</a>	[2] -9	-	+9	ns
$t_{FEOPR}$	receiver SE0 width	accepted as EOP; see <a href="#">Figure 16</a>	[2] 82	-	-	ns
$t_{FST}$	width of SE0 during differential transition	rejected as EOP; see <a href="#">Figure 18</a>	[2] -	-	14	ns

[1] Excluding the first transition from the idle state.

[2] Characterized only, not tested. Limits guaranteed by design.

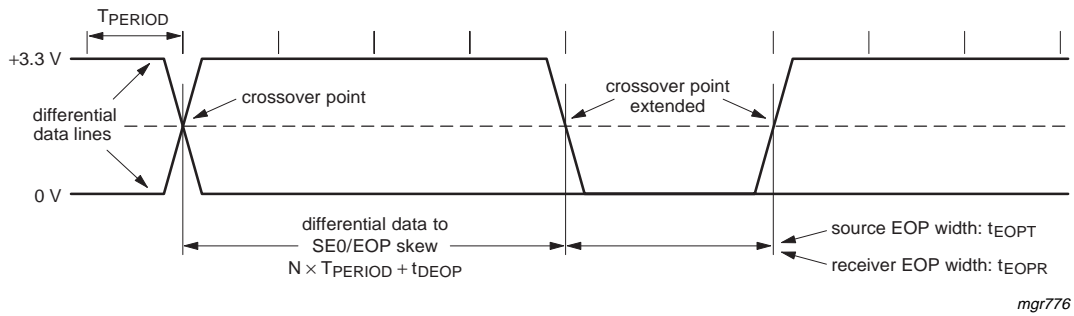

mgr776

$T_{PERIOD}$  is the bit duration corresponding with the USB data rate.

Full-speed timing symbols have a subscript prefix 'F', low-speed timing symbols have a prefix 'L'.

**Fig 16. Source differential data-to-EOP transition skew and EOP width.**

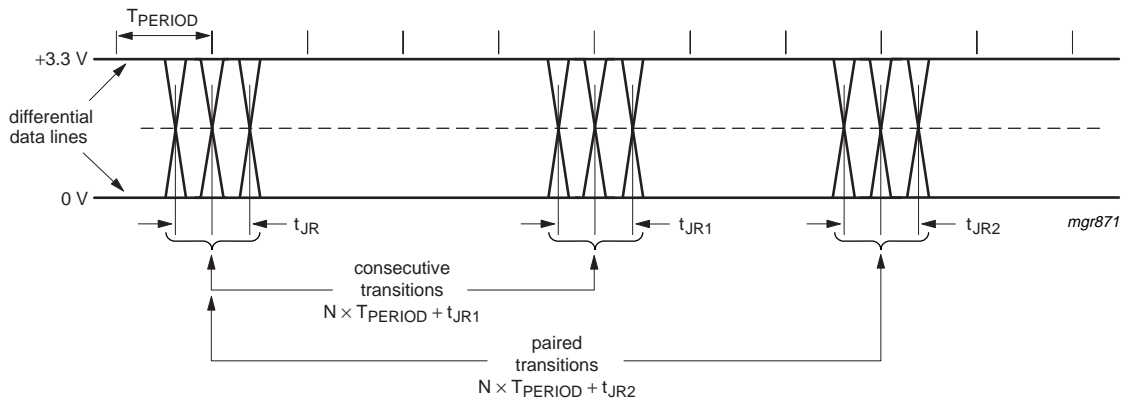

mgr871

$T_{PERIOD}$  is the bit duration corresponding with the USB data rate.

**Fig 17. Receiver differential data jitter.**

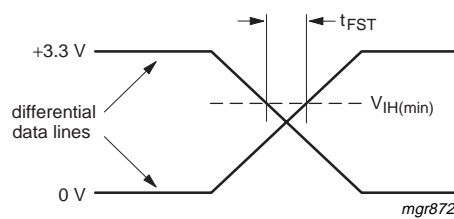

mgr872

**Fig 18. Receiver SE0 width tolerance.**

### 13.1 Register access timing

**Table 85: Register access timing parameters: separate address and data buses**

$V_{CC(I/O)} = V_{CC} = 3.3\text{ V}$ ;  $V_{GND} = 0\text{ V}$ ;  $T_{amb} = -40^\circ\text{C to } +85^\circ\text{C}$ .

Symbol	Parameter	Min	Max	Unit
<b>Reading</b>				
$t_{RLRH}$	RD_N LOW pulse width	$>t_{RLDV}$	-	ns
$t_{AVRL}$	address set-up time before RD_N LOW	0	-	ns
$t_{RHAX}$	address hold time after RD_N HIGH	0	-	ns
$t_{RLDV}$	RD_N LOW to data valid delay	-	26	ns
$t_{RHDZ}$	RD_N HIGH to data outputs three-state delay	0	15	ns
$t_{RHSH}$	RD_N HIGH to CS_N HIGH delay	0	-	ns
$t_{SLRL}$	CS_N LOW to RD_N LOW delay	2	-	ns
<b>Writing</b>				
$t_{WLWH}$	WR_N LOW pulse width	15	-	ns
$t_{AVWL}$	address set-up time before WR_N LOW	0	-	ns
$t_{WHAX}$	address hold time after WR_N HIGH	0	-	ns
$t_{DVWH}$	data set-up time before WR_N HIGH	11	-	ns
$t_{WHDZ}$	data hold time after WR_N HIGH	5	-	ns
$t_{WHSH}$	WR_N HIGH to CS_N HIGH delay	0	-	ns
$t_{SLWL}$	CS_N LOW to WR_N LOW delay	2	-	ns
<b>General</b>				
$T_{cy(RW)}$	read/write cycle time	50	-	ns

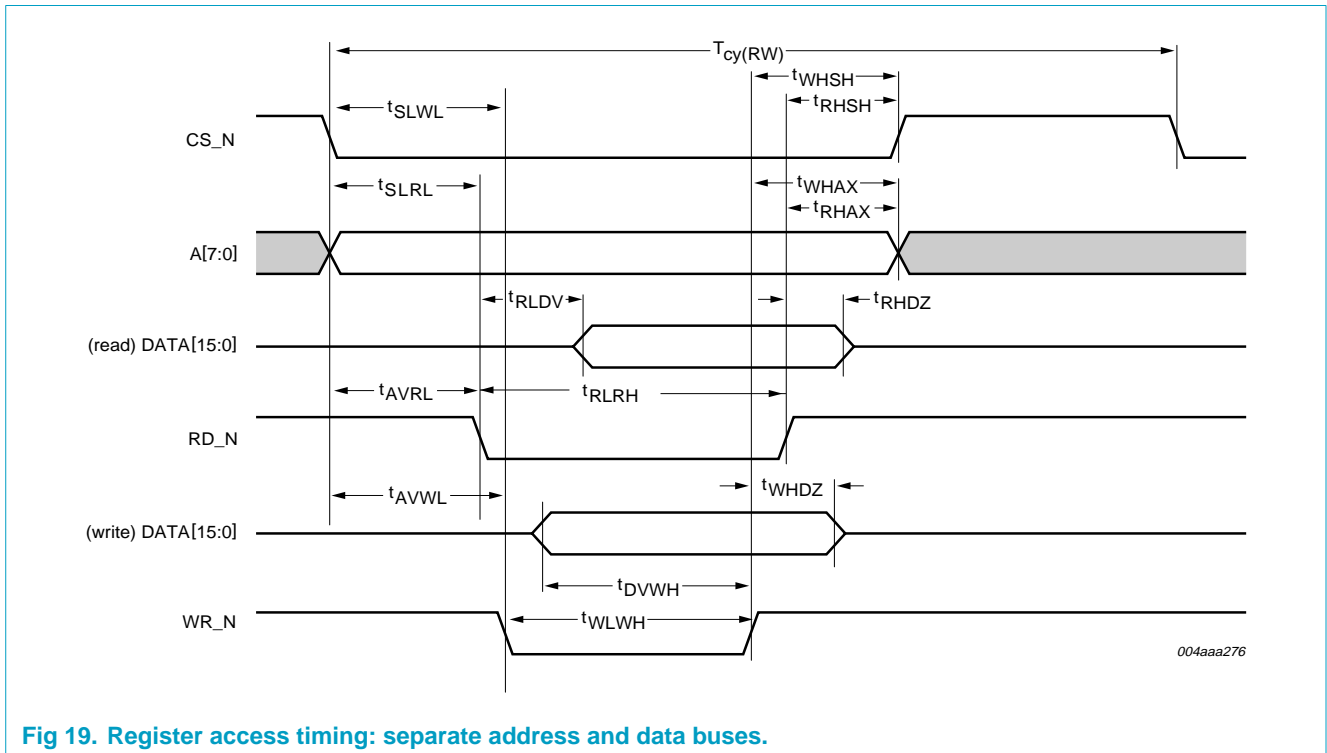

**Fig 19. Register access timing: separate address and data buses.**

### 13.2 DMA timing

**Table 86: GDMA (slave) mode timing parameters**

$V_{CC(I/O)} = V_{CC} = 3.3\text{ V}$ ;  $V_{GND} = 0\text{ V}$ ;  $T_{amb} = -40\text{ }^{\circ}\text{C to } +85\text{ }^{\circ}\text{C}$ .

Symbol	Parameter	Min	Max	Unit
$T_{cy1}$	read/write cycle time	75	-	ns
$t_{su1}$	DREQ set-up time before first DACK on	10	-	ns
$t_{d1}$	DREQ on delay after last strobe off	33.33	-	ns
$t_{h1}$	DREQ hold time after last strobe on	0	53	ns
$t_{w1}$	DIOR/DIOW pulse width	39	600	ns
$t_{w2}$	DIOR/DIOW recovery time	36	-	ns
$t_{d2}$	read data valid delay after strobe on	-	20	ns
$t_{h2}$	read data hold time after strobe off	-	5	ns
$t_{h3}$	write data hold time after strobe off	1	-	ns
$t_{su2}$	write data set-up time before strobe off	10	-	ns
$t_{su3}$	DACK set-up time before DIOR/DIOW assertion	0	-	ns
$t_{a1}$	DACK deassertion after DIOR/DIOW deassertion	0	30	ns

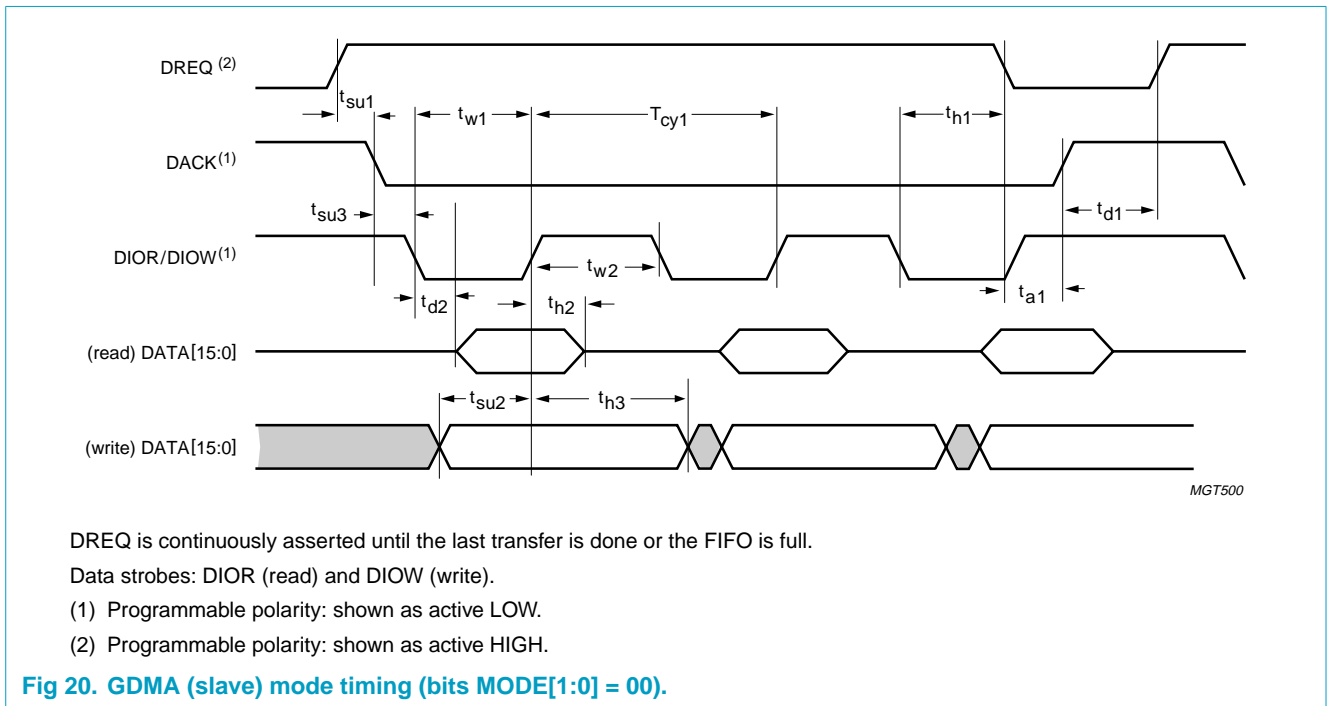

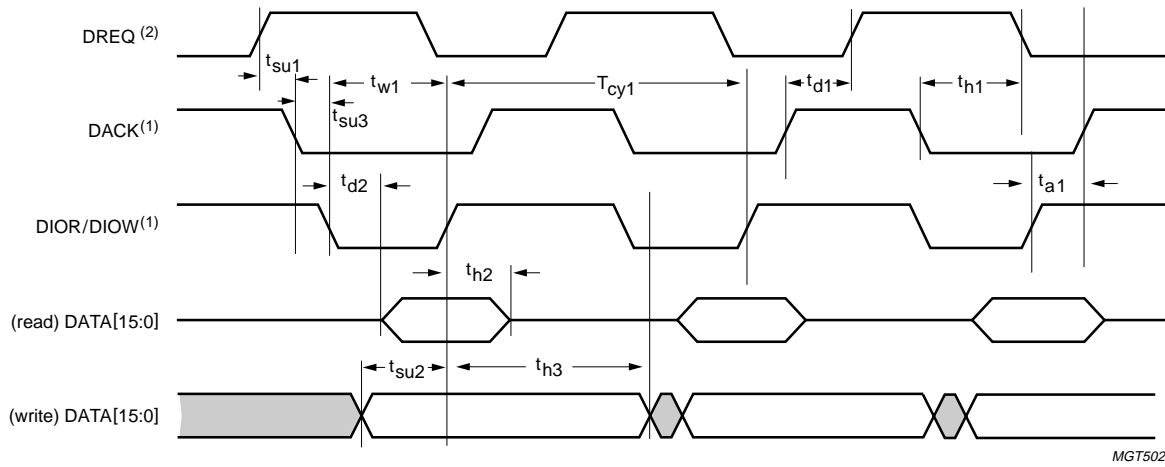

DREQ is asserted for every transfer.  
 Data strobes: DIOR (read) and DACK (write).  
 (1) Programmable polarity: shown as active LOW.  
 (2) Programmable polarity: shown as active HIGH.

Fig 21. GDMA (slave) mode timing (bits MODE[1:0] = 01).

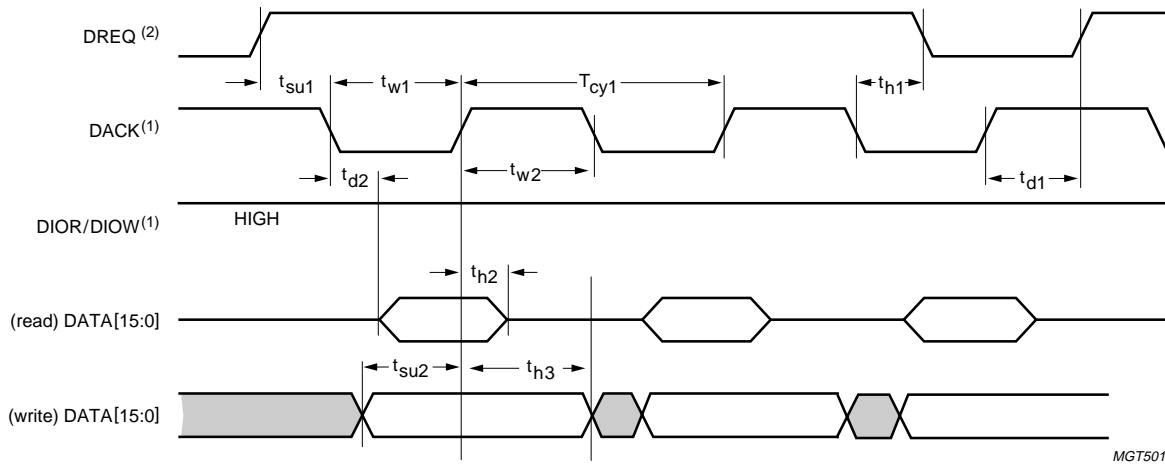

DREQ is continuously asserted until the last transfer is done or the FIFO is full.  
 Data strobe: DACK (read/write).  
 (1) Programmable polarity: shown as active LOW.  
 (2) Programmable polarity: shown as active HIGH.

Fig 22. GDMA (slave) mode timing (bits MODE[1:0] = 10).

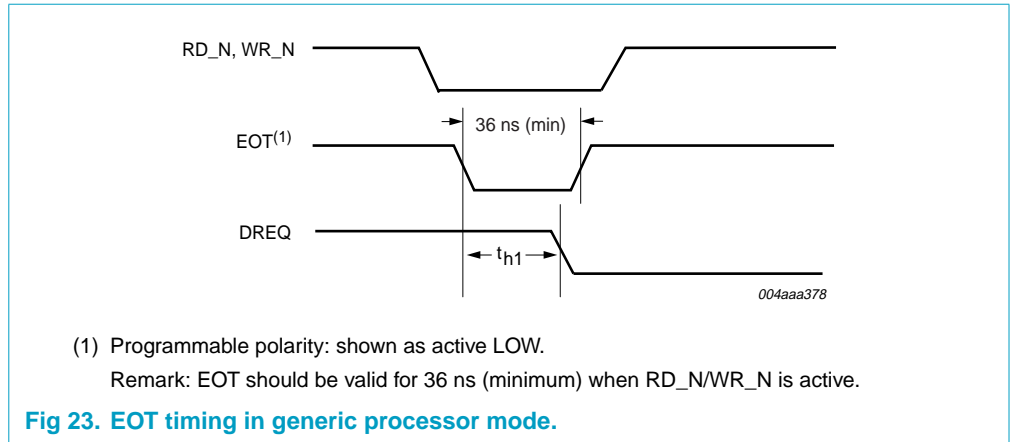

### 14. Application information

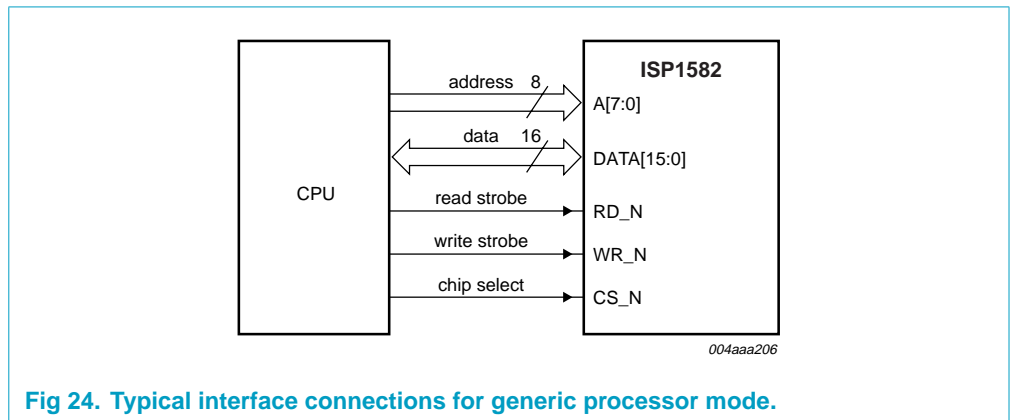

### 15. Test information

The dynamic characteristics of the analog I/O ports DP and DM were determined using the circuit shown in **Figure 25**.

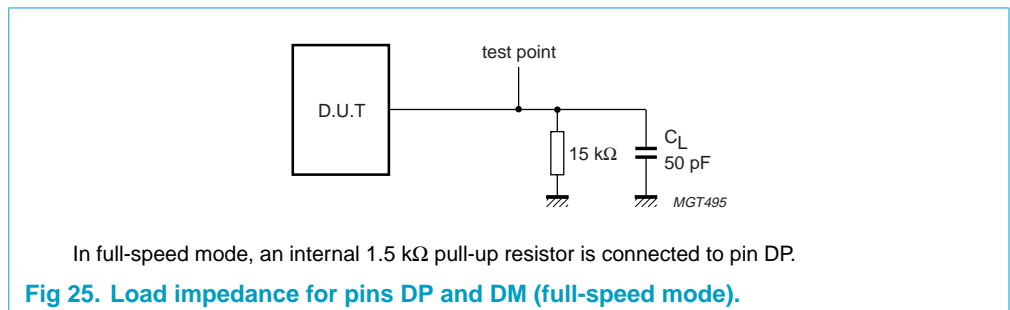

16. Package outline

HVQFN56: plastic thermal enhanced very thin quad flat package; no leads; 56 terminals; body 8 x 8 x 0.85 mm

SOT684-1

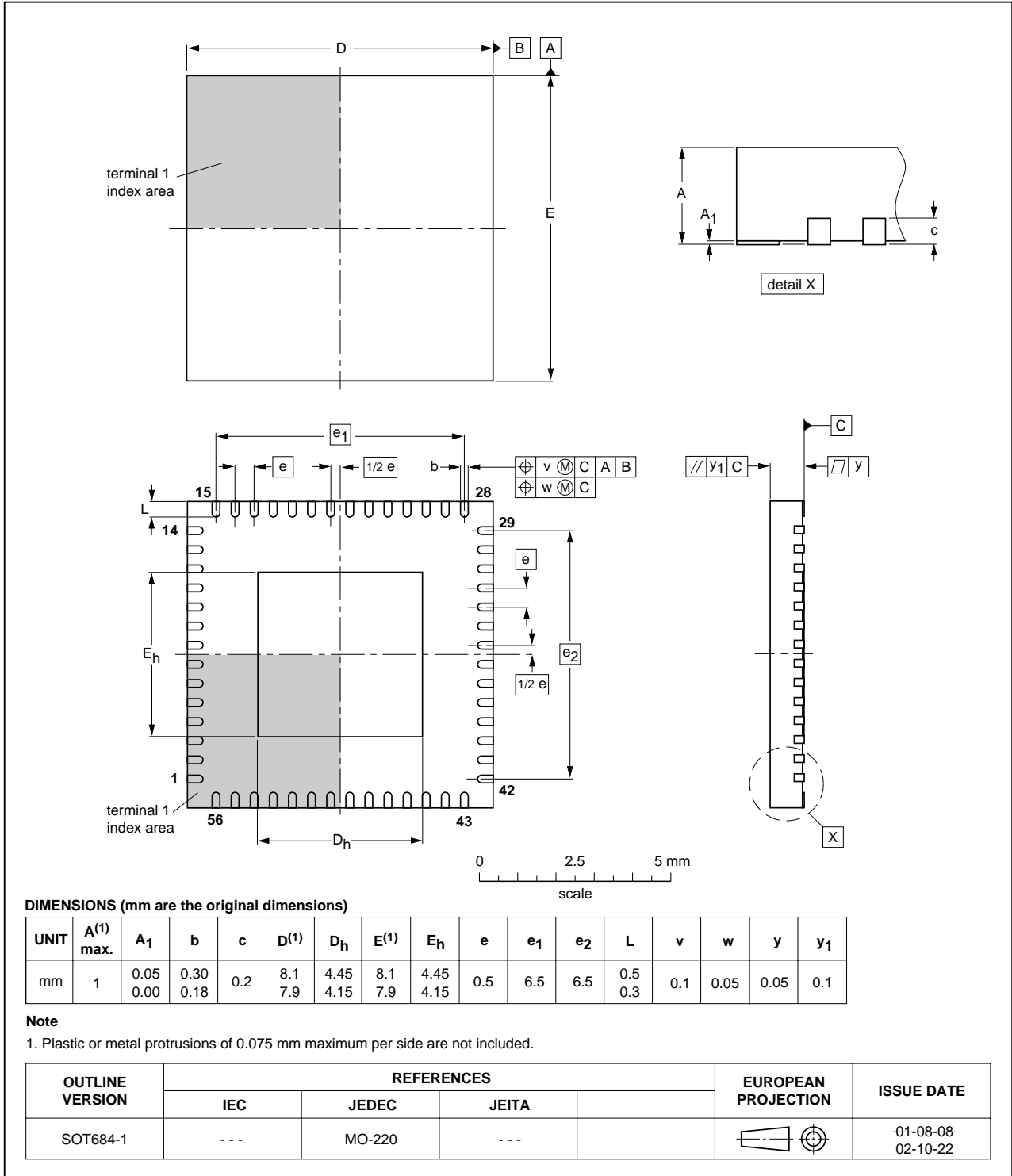

Fig 26. HVQFN56 package outline.

## 17. Soldering

### 17.1 Introduction to soldering surface mount packages

This text gives a very brief insight to a complex technology. A more in-depth account of soldering ICs can be found in our *Data Handbook IC26; Integrated Circuit Packages* (document order number 9398 652 90011).

There is no soldering method that is ideal for all surface mount IC packages. Wave soldering can still be used for certain surface mount ICs, but it is not suitable for fine pitch SMDs. In these situations reflow soldering is recommended. In these situations reflow soldering is recommended.

### 17.2 Reflow soldering

Reflow soldering requires solder paste (a suspension of fine solder particles, flux and binding agent) to be applied to the printed-circuit board by screen printing, stencilling or pressure-syringe dispensing before package placement. Driven by legislation and environmental forces the worldwide use of lead-free solder pastes is increasing.

Several methods exist for reflowing; for example, convection or convection/infrared heating in a conveyor type oven. Throughput times (preheating, soldering and cooling) vary between 100 and 200 seconds depending on heating method.

Typical reflow peak temperatures range from 215 to 270 °C depending on solder paste material. The top-surface temperature of the packages should preferably be kept:

- below 225 °C (SnPb process) or below 245 °C (Pb-free process)
  - for all BGA, HTSSON..T and SSOP..T packages
  - for packages with a thickness  $\geq 2.5$  mm
  - for packages with a thickness  $< 2.5$  mm and a volume  $\geq 350$  mm<sup>3</sup> so called thick/large packages.
- below 240 °C (SnPb process) or below 260 °C (Pb-free process) for packages with a thickness  $< 2.5$  mm and a volume  $< 350$  mm<sup>3</sup> so called small/thin packages.

Moisture sensitivity precautions, as indicated on packing, must be respected at all times.

### 17.3 Wave soldering

Conventional single wave soldering is not recommended for surface mount devices (SMDs) or printed-circuit boards with a high component density, as solder bridging and non-wetting can present major problems.

To overcome these problems the double-wave soldering method was specifically developed.

If wave soldering is used the following conditions must be observed for optimal results:

- Use a double-wave soldering method comprising a turbulent wave with high upward pressure followed by a smooth laminar wave.

- For packages with leads on two sides and a pitch (e):
  - larger than or equal to 1.27 mm, the footprint longitudinal axis is **preferred** to be parallel to the transport direction of the printed-circuit board;
  - smaller than 1.27 mm, the footprint longitudinal axis **must** be parallel to the transport direction of the printed-circuit board.

The footprint must incorporate solder thieves at the downstream end.

- For packages with leads on four sides, the footprint must be placed at a 45° angle to the transport direction of the printed-circuit board. The footprint must incorporate solder thieves downstream and at the side corners.

During placement and before soldering, the package must be fixed with a droplet of adhesive. The adhesive can be applied by screen printing, pin transfer or syringe dispensing. The package can be soldered after the adhesive is cured.

Typical dwell time of the leads in the wave ranges from 3 to 4 seconds at 250 °C or 265 °C, depending on solder material applied, SnPb or Pb-free respectively.

A mildly-activated flux will eliminate the need for removal of corrosive residues in most applications.

## 17.4 Manual soldering

Fix the component by first soldering two diagonally-opposite end leads. Use a low voltage (24 V or less) soldering iron applied to the flat part of the lead. Contact time must be limited to 10 seconds at up to 300 °C.

When using a dedicated tool, all other leads can be soldered in one operation within 2 to 5 seconds between 270 and 320 °C.

## 17.5 Package related soldering information

**Table 87: Suitability of surface mount IC packages for wave and reflow soldering methods**

Package <sup>[1]</sup>	Soldering method	
	Wave	Reflow <sup>[2]</sup>
BGA, HTSSON..T <sup>[3]</sup> , LBGA, LFBGA, SQFP, SSOP..T <sup>[3]</sup> , TFBGA, USON, VFBGA	not suitable	suitable
DHVQFN, HBCC, HBGA, HLQFP, HSO, HSOP, HSQFP, HSSON, HTQFP, HTSSOP, HVQFN, HVSON, SMS	not suitable <sup>[4]</sup>	suitable
PLCC <sup>[5]</sup> , SO, SOJ	suitable	suitable
LQFP, QFP, TQFP	not recommended <sup>[5][6]</sup>	suitable
SSOP, TSSOP, VSO, VSSOP	not recommended <sup>[7]</sup>	suitable
CWQCCN..L <sup>[8]</sup> , PMFP <sup>[9]</sup> , WQCCN..L <sup>[8]</sup>	not suitable	not suitable

[1] For more detailed information on the BGA packages refer to the *(LF)BGA Application Note* (AN01026); order a copy from your Philips Semiconductors sales office.

[2] All surface mount (SMD) packages are moisture sensitive. Depending upon the moisture content, the maximum temperature (with respect to time) and body size of the package, there is a risk that internal or external package cracks may occur due to vaporization of the moisture in them (the so called popcorn effect). For details, refer to the Drypack information in the *Data Handbook IC26; Integrated Circuit Packages; Section: Packing Methods*.

- [3] These transparent plastic packages are extremely sensitive to reflow soldering conditions and must on no account be processed through more than one soldering cycle or subjected to infrared reflow soldering with peak temperature exceeding  $217\text{ }^{\circ}\text{C} \pm 10\text{ }^{\circ}\text{C}$  measured in the atmosphere of the reflow oven. The package body peak temperature must be kept as low as possible.
- [4] These packages are not suitable for wave soldering. On versions with the heatsink on the bottom side, the solder cannot penetrate between the printed-circuit board and the heatsink. On versions with the heatsink on the top side, the solder might be deposited on the heatsink surface.
- [5] If wave soldering is considered, then the package must be placed at a  $45^{\circ}$  angle to the solder wave direction. The package footprint must incorporate solder thieves downstream and at the side corners.
- [6] Wave soldering is suitable for LQFP, QFP and TQFP packages with a pitch (e) larger than 0.8 mm; it is definitely not suitable for packages with a pitch (e) equal to or smaller than 0.65 mm.
- [7] Wave soldering is suitable for SSOP, TSSOP, VSO and VSOP packages with a pitch (e) equal to or larger than 0.65 mm; it is definitely not suitable for packages with a pitch (e) equal to or smaller than 0.5 mm.
- [8] Image sensor packages in principle should not be soldered. They are mounted in sockets or delivered pre-mounted on flex foil. However, the image sensor package can be mounted by the client on a flex foil by using a hot bar soldering process. The appropriate soldering profile can be provided on request.
- [9] Hot bar soldering or manual soldering is suitable for PMFP packages.

## 18. Revision history

Table 88: Revision history

Rev	Date	CPCN	Description
03	2004xxxx	-	<b>Preliminary data (9397 750 13699)</b> Modifications: <ul style="list-style-type: none"> <li>• Globally changed <math>V_{CC(I/O)}</math> to the same value as <math>V_{CC}</math>.</li> <li>• <b>Table 2 "Pin description"</b>: updated pin description for EOT, DACK, DIOW and DIOR; also removed table note 3.</li> <li>• <b>Section 8.14.1 "Power-sharing mode"</b>: added Remark.</li> <li>• <b>Section 9.5.4 "Scratch register (address: 78h)"</b>: updated the bus reset value.</li> </ul>
02	20040629	-	<b>Preliminary data (9397 750 12979)</b>
01	20040223	-	<b>Preliminary data (9397 750 11496)</b>

## 19. Data sheet status

Level	Data sheet status <sup>[1]</sup>	Product status <sup>[2][3]</sup>	Definition
I	Objective data	Development	This data sheet contains data from the objective specification for product development. Philips Semiconductors reserves the right to change the specification in any manner without notice.
II	Preliminary data	Qualification	This data sheet contains data from the preliminary specification. Supplementary data will be published at a later date. Philips Semiconductors reserves the right to change the specification without notice, in order to improve the design and supply the best possible product.
III	Product data	Production	This data sheet contains data from the product specification. Philips Semiconductors reserves the right to make changes at any time in order to improve the design, manufacturing and supply. Relevant changes will be communicated via a Customer Product/Process Change Notification (CPCN).

[1] Please consult the most recently issued data sheet before initiating or completing a design.

[2] The product status of the device(s) described in this data sheet may have changed since this data sheet was published. The latest information is available on the Internet at URL <http://www.semiconductors.philips.com>.

[3] For data sheets describing multiple type numbers, the highest-level product status determines the data sheet status.

## 20. Definitions

**Short-form specification** — The data in a short-form specification is extracted from a full data sheet with the same type number and title. For detailed information see the relevant data sheet or data handbook.

**Limiting values definition** — Limiting values given are in accordance with the Absolute Maximum Rating System (IEC 60134). Stress above one or more of the limiting values may cause permanent damage to the device. These are stress ratings only and operation of the device at these or at any other conditions above those given in the Characteristics sections of the specification is not implied. Exposure to limiting values for extended periods may affect device reliability.

**Application information** — Applications that are described herein for any of these products are for illustrative purposes only. Philips Semiconductors make no representation or warranty that such applications will be suitable for the specified use without further testing or modification.

## 21. Disclaimers

**Life support** — These products are not designed for use in life support appliances, devices, or systems where malfunction of these products can reasonably be expected to result in personal injury. Philips Semiconductors

customers using or selling these products for use in such applications do so at their own risk and agree to fully indemnify Philips Semiconductors for any damages resulting from such application.

**Right to make changes** — Philips Semiconductors reserves the right to make changes in the products - including circuits, standard cells, and/or software - described or contained herein in order to improve design and/or performance. When the product is in full production (status 'Production'), relevant changes will be communicated via a Customer Product/Process Change Notification (CPCN). Philips Semiconductors assumes no responsibility or liability for the use of any of these products, conveys no licence or title under any patent, copyright, or mask work right to these products, and makes no representations or warranties that these products are free from patent, copyright, or mask work right infringement, unless otherwise specified.

## 22. Trademarks

**ACPI** — is an open industry specification for PC power management, co-developed by Intel Corp., Microsoft Corp. and Toshiba

**OnNow** — is a trademark of Microsoft Corp.

**SoftConnect** — is a trademark of Koninklijke Philips Electronics N.V.

## Contact information

For additional information, please visit <http://www.semiconductors.philips.com>.

For sales office addresses, send e-mail to: [sales.addresses@www.semiconductors.philips.com](mailto:sales.addresses@www.semiconductors.philips.com).

Fax: +31 40 27 24825

## Contents

<b>1</b>	<b>General description</b> . . . . .	<b>1</b>	9.3.6	Endpoint MaxPacketSize register (address: 04h) . . . . .	36
<b>2</b>	<b>Features</b> . . . . .	<b>2</b>	9.3.7	Endpoint Type register (address: 08h) . . . . .	37
<b>3</b>	<b>Applications</b> . . . . .	<b>2</b>	9.4	DMA registers . . . . .	38
<b>4</b>	<b>Abbreviations</b> . . . . .	<b>3</b>	9.4.1	DMA Command register (address: 30h) . . . . .	39
<b>5</b>	<b>Ordering information</b> . . . . .	<b>3</b>	9.4.2	DMA Transfer Counter register (address: 34h) . . . . .	40
<b>6</b>	<b>Block diagram</b> . . . . .	<b>4</b>	9.4.3	DMA Configuration register (address: 38h) . . . . .	41
<b>7</b>	<b>Pinning information</b> . . . . .	<b>5</b>	9.4.4	DMA Hardware register (address: 3Ch) . . . . .	42
7.1	Pinning . . . . .	5	9.4.5	DMA Interrupt Reason register (address: 50h) . . . . .	43
7.2	Pin description . . . . .	6	9.4.6	DMA Interrupt Enable register (address: 54h) . . . . .	45
<b>8</b>	<b>Functional description</b> . . . . .	<b>10</b>	9.4.7	DMA Endpoint register (address: 58h) . . . . .	45
8.1	DMA interface, DMA handler and DMA registers . . . . .	10	9.4.8	DMA Burst Counter register (address: 64h) . . . . .	46
8.2	Hi-Speed USB transceiver . . . . .	11	9.5	General registers . . . . .	46
8.3	MMU and integrated RAM . . . . .	11	9.5.1	Interrupt register (address: 18h) . . . . .	46
8.4	Microcontroller interface and microcontroller handler . . . . .	11	9.5.2	Chip ID register (address: 70h) . . . . .	48
8.5	OTG SRP module . . . . .	11	9.5.3	Frame Number register (address: 74h) . . . . .	49
8.6	Philips high-speed transceiver . . . . .	11	9.5.4	Scratch register (address: 78h) . . . . .	49
8.6.1	Philips Parallel Interface Engine (PIE) . . . . .	11	9.5.5	Unlock Device register (address: 7Ch) . . . . .	50
8.6.2	Peripheral circuit . . . . .	11	9.5.6	Test Mode register (address: 84h) . . . . .	51
8.6.3	HS detection . . . . .	12	<b>10</b>	<b>Limiting values</b> . . . . .	<b>52</b>
8.7	Philips Serial Interface Engine (SIE) . . . . .	12	<b>11</b>	<b>Recommended operating conditions</b> . . . . .	<b>52</b>
8.8	SoftConnect . . . . .	12	<b>12</b>	<b>Static characteristics</b> . . . . .	<b>53</b>
8.9	System controller . . . . .	12	<b>13</b>	<b>Dynamic characteristics</b> . . . . .	<b>54</b>
8.10	Output pins status . . . . .	12	13.1	Register access timing . . . . .	57
8.11	Interrupt . . . . .	13	13.2	DMA timing . . . . .	58
8.11.1	Interrupt output pin . . . . .	13	<b>14</b>	<b>Application information</b> . . . . .	<b>60</b>
8.11.2	Interrupt control . . . . .	15	<b>15</b>	<b>Test information</b> . . . . .	<b>60</b>
8.12	V <sub>BUS</sub> sensing . . . . .	15	<b>16</b>	<b>Package outline</b> . . . . .	<b>61</b>
8.13	Power-on reset . . . . .	16	<b>17</b>	<b>Soldering</b> . . . . .	<b>62</b>
8.14	Power supply . . . . .	17	17.1	Introduction to soldering surface mount packages . . . . .	62
8.14.1	Power-sharing mode . . . . .	18	17.2	Reflow soldering . . . . .	62
8.14.2	Self-powered mode . . . . .	20	17.3	Wave soldering . . . . .	62
8.14.3	Bus-powered mode . . . . .	21	17.4	Manual soldering . . . . .	63
<b>9</b>	<b>Register description</b> . . . . .	<b>23</b>	17.5	Package related soldering information . . . . .	63
9.1	Register access . . . . .	24	<b>18</b>	<b>Revision history</b> . . . . .	<b>64</b>
9.2	Initialization registers . . . . .	24	<b>19</b>	<b>Data sheet status</b> . . . . .	<b>65</b>
9.2.1	Address register (address: 00h) . . . . .	24	<b>20</b>	<b>Definitions</b> . . . . .	<b>65</b>
9.2.2	Mode register (address: 0Ch) . . . . .	25	<b>21</b>	<b>Disclaimers</b> . . . . .	<b>65</b>
9.2.3	Interrupt Configuration register (address: 10h) . . . . .	27	<b>22</b>	<b>Trademarks</b> . . . . .	<b>65</b>
9.2.4	OTG register (address: 12h) . . . . .	28			
9.2.5	Interrupt Enable register (address: 14h) . . . . .	30			
9.3	Data flow registers . . . . .	31			
9.3.1	Endpoint Index register (address: 2Ch) . . . . .	31			
9.3.2	Control Function register (address: 28h) . . . . .	33			
9.3.3	Data Port register (address: 20h) . . . . .	33			
9.3.4	Buffer Length register (address: 1Ch) . . . . .	34			
9.3.5	Buffer Status register (address: 1Eh) . . . . .	35			



**PHILIPS**

*Let's make things better.*



LittleDiode supplies new, hard to find or obsolete electronic components and semiconductors all over the world.

With over two million different components listed you are sure to find the part you need.

Feel free to visit us today at our online store:

**[LittleDiode.com](http://LittleDiode.com)**

Looking forward to providing you with the best possible service.