

Features

- **SuperFAST HIGH DENSITY IN-SYSTEM PROGRAMMABLE LOGIC**
 - 1000 PLD Gates
 - 32 I/O Pins, Two Dedicated Inputs
 - 32 Registers
 - High Speed Global Interconnect
 - Wide Input Gating for Fast Counters, State Machines, Address Decoders, etc.
 - Small Logic Block Size for Random Logic
 - 100% Functional, JEDEC and Pinout Compatible with ispLSI 2032V Devices
- **3.3V LOW VOLTAGE 2032 ARCHITECTURE**
 - Interfaces With Standard 5V TTL Devices
- **HIGH PERFORMANCE E²CMOS[®] TECHNOLOGY**
 - $f_{max} = 225$ MHz Maximum Operating Frequency
 - $t_{pd} = 4.0$ ns Propagation Delay
 - Electrically Erasable and Reprogrammable
 - Non-Volatile
 - 100% Tested at Time of Manufacture
 - Unused Product Term Shutdown Saves Power
- **IN-SYSTEM PROGRAMMABLE**
 - 3.3V In-System Programmability Using Boundary Scan Test Access Port (TAP)
 - Open-Drain Output Option for Flexible Bus Interface Capability, Allowing Easy Implementation of Wired-OR or Bus Arbitration Logic
 - Increased Manufacturing Yields, Reduced Time-to-Market and Improved Product Quality
 - Reprogram Soldered Devices for Faster Prototyping
- **100% IEEE 1149.1 BOUNDARY SCAN TESTABLE**
- **THE EASE OF USE AND FAST SYSTEM SPEED OF PLDs WITH THE DENSITY AND FLEXIBILITY OF FPGAs**
 - Enhanced Pin Locking Capability
 - Three Dedicated Clock Input Pins
 - Synchronous and Asynchronous Clocks
 - Programmable Output Slew Rate Control
 - Flexible Pin Placement
 - Optimized Global Routing Pool Provides Global Interconnectivity
- **ispDesignEXPERT™ – LOGIC COMPILER AND COMPLETE ISP DEVICE DESIGN SYSTEMS FROM HDL SYNTHESIS THROUGH IN-SYSTEM PROGRAMMING**
 - Superior Quality of Results
 - Tightly Integrated with Leading CAE Vendor Tools
 - Productivity Enhancing Timing Analyzer, Explore Tools, Timing Simulator and ispANALYZER™
 - PC and UNIX Platforms

Functional Block Diagram

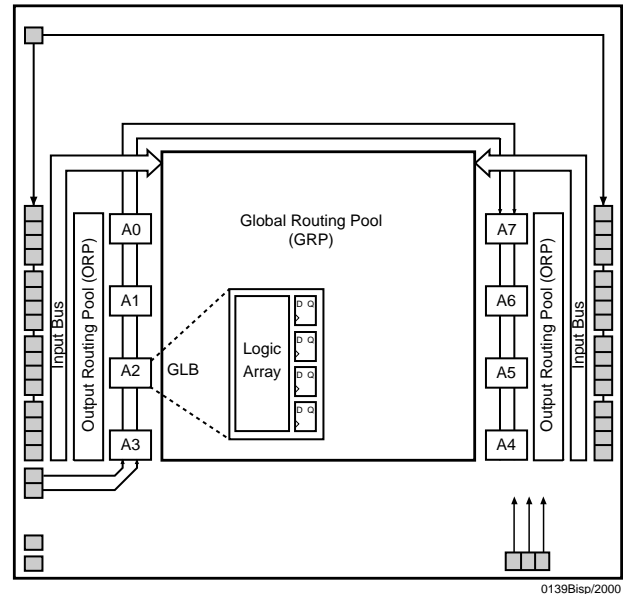

Description

The ispLSI 2032VE is a High Density Programmable Logic Device that can be used in both 3.3V and 5V systems. The device contains 32 Registers, 32 Universal I/O pins, two Dedicated Input Pins, three Dedicated Clock Input Pins, one dedicated Global OE input pin and a Global Routing Pool (GRP). The GRP provides complete interconnectivity between all of these elements. The ispLSI 2032VE features in-system programmability through the Boundary Scan Test Access Port (TAP) and is 100% IEEE 1149.1 Boundary Scan Testable. The ispLSI 2032VE offers non-volatile reprogrammability of the logic, as well as the interconnect to provide truly reconfigurable systems.

The basic unit of logic on the ispLSI 2032VE device is the Generic Logic Block (GLB). The GLBs are labeled A0, A1 .. A7 (see Figure 1). There are a total of eight GLBs in the ispLSI 2032VE device. Each GLB is made up of four macrocells. Each GLB has 18 inputs, a programmable AND/OR/Exclusive OR array, and four outputs which can be configured to be either combinatorial or registered. Inputs to the GLB come from the GRP and dedicated inputs. All of the GLB outputs are brought back into the GRP so that they can be connected to the inputs of any GLB on the device.

Functional Block Diagram

Figure 1. ispLSI 2032VE Functional Block Diagram

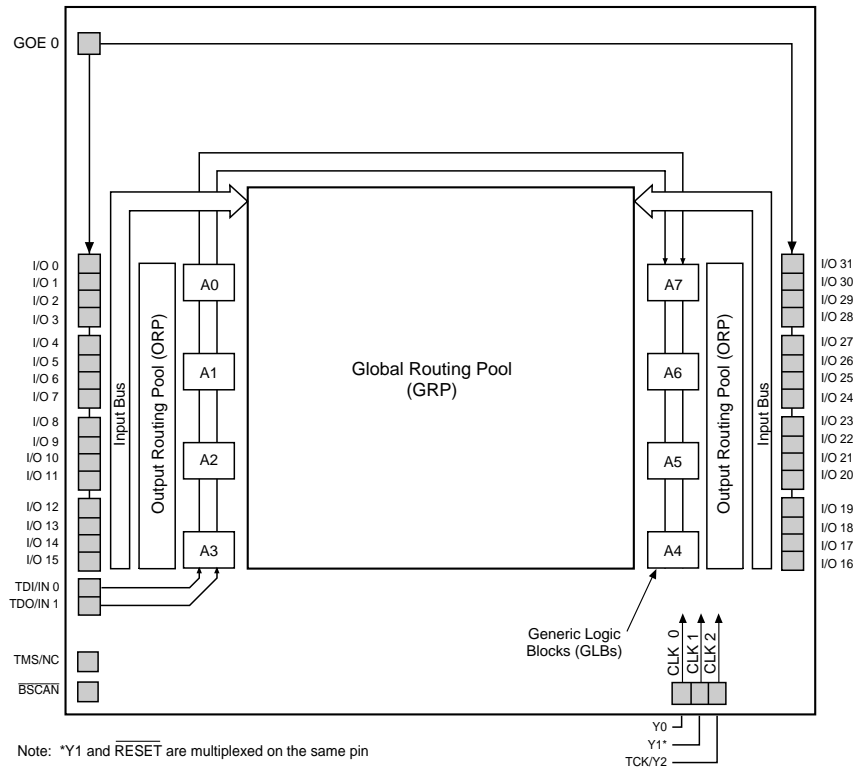

The device also has 32 I/O cells, each of which is directly connected to an I/O pin. Each I/O cell can be individually programmed to be a combinatorial input, output or bi-directional I/O pin with 3-state control. The signal levels are TTL compatible voltages and the output drivers can source 4 mA or sink 8 mA. Each output can be programmed independently for fast or slow output slew rate to minimize overall output switching noise. Device pins can be safely driven to 5 Volt signal levels to support mixed-voltage systems.

Eight GLBs, 32 I/O cells, two dedicated inputs and two ORPs are connected together to make a Megablock (see Figure 1). The outputs of the eight GLBs are connected to a set of 32 universal I/O cells by the ORP. Each ispLSI 2032VE device contains one Megablock.

The GRP has as its inputs the outputs from all of the GLBs and all of the inputs from the bi-directional I/O cells. All of these signals are made available to the inputs of the GLBs. Delays through the GRP have been equalized to minimize timing skew.

Clocks in the ispLSI 2032VE device are selected using the dedicated clock pins. Three dedicated clock pins (Y0, Y1, Y2) or an asynchronous clock can be selected on a GLB basis. The asynchronous or Product Term clock can be generated in any GLB for its own clock.

Programmable Open-Drain Outputs

In addition to the standard output configuration, the outputs of the ispLSI 2032VE are individually programmable, either as a standard totem-pole output or an open-drain output. The totem-pole output drives the specified Voh and Vol levels, whereas the open-drain output drives only the specified Vol. The Voh level on the open-drain output depends on the external loading and pull-up. This output configuration is controlled by a programmable fuse. The default configuration when the device is in bulk erased state is totem-pole configuration. The open-drain/totem-pole option is selectable through the ispDesignEXPERT software tools.

Absolute Maximum Ratings ¹

Supply Voltage V_{CC} -0.5 to +5.4V
 Input Voltage Applied -0.5 to +5.6V
 Off-State Output Voltage Applied -0.5 to +5.6V
 Storage Temperature -65 to +150°C
 Case Temp. with Power Applied -55 to 125°C
 Max. Junction Temp. (T_J) with Power Applied ... 150°C

1. Stresses above those listed under the “Absolute Maximum Ratings” may cause permanent damage to the device. Functional operation of the device at these or at any other conditions above those indicated in the operational sections of this specification is not implied (while programming, follow the programming specifications).

DC Recommended Operating Condition

SYMBOL	PARAMETER	MIN.	MAX.	UNITS	
V_{CC}	Supply Voltage	Commercial $T_A = 0^\circ\text{C to } +70^\circ\text{C}$	3.0	3.6	V
		Industrial $T_A = -40^\circ\text{C to } +85^\circ\text{C}$	3.0	3.6	V
V_{IL}	Input Low Voltage	$V_{SS} - 0.5$	0.8	V	
V_{IH}	Input High Voltage	2.0	5.25	V	

Table 2-0005/2032VE

Capacitance ($T_A=25^\circ\text{C}$, $f=1.0\text{ MHz}$)

SYMBOL	PARAMETER	TYPICAL	UNITS	TEST CONDITIONS
C_1	Dedicated Input Capacitance	8	pf	$V_{CC} = 3.3\text{V}$, $V_{IN} = 0.0\text{V}$
C_2	I/O Capacitance	6	pf	$V_{CC} = 3.3\text{V}$, $V_{I/O} = 0.0\text{V}$
C_3	Clock Capacitance	10	pf	$V_{CC} = 3.3\text{V}$, $V_Y = 0.0\text{V}$

Table 2-0006/2032VE

Erase Reprogram Specifications

PARAMETER	MINIMUM	MAXIMUM	UNITS
Erase/Reprogram Cycles	10,000	–	Cycles

Table 2-0008A/2032VE

Switching Test Conditions

Input Pulse Levels	GND to 3.0V
Input Rise and Fall Time 10% to 90%	≤ 1.5 ns
Input Timing Reference Levels	1.5V
Output Timing Reference Levels	1.5V
Output Load	See Figure 2

3-state levels are measured 0.5V from steady-state active level.

Table 2-0003/2032VE

Output Load Conditions (see Figure 2)

TEST CONDITION		R1	R2	CL
A		316Ω	348Ω	35pF
B	Active High	∞	348Ω	35pF
	Active Low	316Ω	348Ω	35pF
C	Active High to Z at $V_{OH}-0.5V$	∞	348Ω	5pF
	Active Low to Z at $V_{OL}+0.5V$	316Ω	348Ω	5pF

Table 2-0004A/2032VE

Figure 2. Test Load

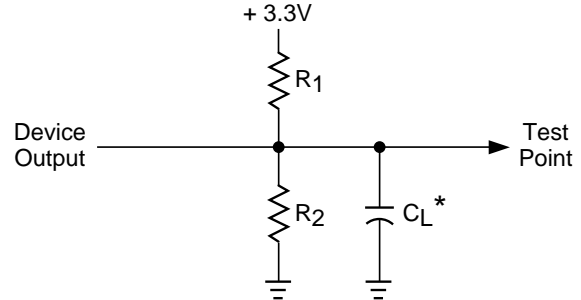

*CL includes Test Fixture and Probe Capacitance.

0213A/2032VE

DC Electrical Characteristics

Over Recommended Operating Conditions

SYMBOL	PARAMETER	CONDITION	MIN.	TYP. ³	MAX.	UNITS	
V_{OL}	Output Low Voltage	$I_{OL} = 8 \text{ mA}$	-	-	0.4	V	
V_{OH}	Output High Voltage	$I_{OH} = -4 \text{ mA}$	2.4	-	-	V	
I_{IL}	Input or I/O Low Leakage Current	$0V \leq V_{IN} \leq V_{IL}(\text{Max.})$	-	-	-10	μA	
I_{IH}	Input or I/O High Leakage Current	$(V_{CC} - 0.2)V \leq V_{IN} \leq V_{CC}$	-	-	10	μA	
		$V_{CC} \leq V_{IN} \leq 5.25V$	-	-	10	μA	
I_{IL-isp}	BSCAN Input Low Leakage Current	$0V \leq V_{IN} \leq V_{IL}$	-	-	-150	μA	
I_{IL-PU}	I/O Active Pull-Up Current	$0V \leq V_{IN} \leq V_{IL}$	-	-	-150	μA	
I_{OS}¹	Output Short Circuit Current	$V_{CC} = 3.3V, V_{OUT} = 0.5V$	-	-	-100	mA	
I_{CC}^{2, 4, 5}	Operating Power Supply Current	$V_{IL} = 0.0V, V_{IH} = 3.0V$ $f_{TOGGLE} = 1 \text{ MHz}$	-300/-225	-	80	-	mA
		Others	-	-	65	-	mA

Table 2-0007/2032VE

- One output at a time for a maximum duration of one second. $V_{OUT} = 0.5V$ was selected to avoid test problems by tester ground degradation. Characterized but not 100% tested.
- Measured using two 16-bit counters.
- Typical values are at $V_{CC} = 3.3V$ and $T_A = 25^\circ C$.
- Maximum I_{CC} varies widely with specific device configuration and operating frequency. Refer to Power Consumption section of this data sheet and Thermal Management section of the Lattice Semiconductor Data Book or CD-ROM to estimate maximum I_{CC} .
- Unused inputs at $V_{IL} = 0V$.

External Timing Parameters

Over Recommended Operating Conditions

PARAMETER	TEST COND. ³	#	DESCRIPTION ¹	-225 ⁴		-180		UNITS
				MIN.	MAX.	MIN.	MAX.	
t _{pd1}	A	1	Data Propagation Delay, 4PT Bypass, ORP Bypass	–	4.0	–	5.0	ns
t _{pd2}	A	2	Data Propagation Delay	–	6.0	–	7.5	ns
f _{max}	A	3	Clock Frequency with Internal Feedback ²	225	–	180	–	MHz
f _{max} (Ext.)	–	4	Clock Frequency with External Feedback ($\frac{1}{t_{su2} + t_{co1}}$)	154	–	125	–	MHz
f _{max} (Tog.)	–	5	Clock Frequency, Max. Toggle	250	–	200	–	MHz
t _{su1}	–	6	GLB Reg. Setup Time before Clock, 4 PT Bypass	2.5	–	3.0	–	ns
t _{co1}	A	7	GLB Reg. Clock to Output Delay, ORP Bypass	–	3.0	–	4.0	ns
t _{h1}	–	8	GLB Reg. Hold Time after Clock, 4 PT Bypass	0.0	–	0.0	–	ns
t _{su2}	–	9	GLB Reg. Setup Time before Clock	3.5	–	4.0	–	ns
t _{co2}	A	10	GLB Reg. Clock to Output Delay	–	4.0	–	5.0	ns
t _{h2}	–	11	GLB Reg. Hold Time after Clock	0.0	–	0.0	–	ns
t _{tr1}	A	12	Ext. Reset Pin to Output Delay, ORP Bypass	–	5.0	–	6.0	ns
t _{rw1}	–	13	Ext. Reset Pulse Duration	3.5	–	4.0	–	ns
t _{ptoen}	B	14	Input to Output Enable	–	7.0	–	10.0	ns
t _{ptoedis}	C	15	Input to Output Disable	–	7.0	–	10.0	ns
t _{goeen}	B	16	Global OE Output Enable	–	3.5	–	5.0	ns
t _{goedis}	C	17	Global OE Output Disable	–	3.5	–	5.0	ns
t _{wh}	–	18	External Synchronous Clock Pulse Duration, High	2.0	–	2.5	–	ns
t _{wl}	–	19	External Synchronous Clock Pulse Duration, Low	2.0	–	2.5	–	ns

Table 2-0030A/2032VE

1. Unless noted otherwise, all parameters use a GRP load of 4, 20 PTXOR path, ORP and Y0 clock.
2. Standard 16-bit counter using GRP feedback.
3. Reference Switching Test Conditions section.
4. -225 speed grade supercedes earlier -200. All parameters other than f_{max} (internal) are the same.

External Timing Parameters

Over Recommended Operating Conditions

PARAMETER	TEST COND. ³	#	DESCRIPTION ¹	-135		-110		UNITS
				MIN.	MAX.	MIN.	MAX.	
t _{pd1}	A	1	Data Propagation Delay, 4PT Bypass, ORP Bypass	–	7.5	–	10.0	ns
t _{pd2}	A	2	Data Propagation Delay	–	10.0	–	13.0	ns
f _{max}	A	3	Clock Frequency with Internal Feedback ²	135	–	111	–	MHz
f _{max} (Ext.)	–	4	Clock Frequency with External Feedback ($\frac{1}{t_{su2} + t_{co1}}$)	100	–	77.0	–	MHz
f _{max} (Tog.)	–	5	Clock Frequency, Max. Toggle	167	–	125	–	MHz
t _{su1}	–	6	GLB Reg. Setup Time before Clock, 4 PT Bypass	4.0	–	5.5	–	ns
t _{co1}	A	7	GLB Reg. Clock to Output Delay, ORP Bypass	–	4.5	–	5.0	ns
t _{h1}	–	8	GLB Reg. Hold Time after Clock, 4 PT Bypass	0.0	–	0.0	–	ns
t _{su2}	–	9	GLB Reg. Setup Time before Clock	5.5	–	7.5	–	ns
t _{co2}	A	10	GLB Reg. Clock to Output Delay	–	5.5	–	6.5	ns
t _{h2}	–	11	GLB Reg. Hold Time after Clock	0.0	–	0.0	–	ns
t _{r1}	A	12	Ext. Reset Pin to Output Delay, ORP Bypass	–	9.0	–	12.5	ns
t _{rw1}	–	13	Ext. Reset Pulse Duration	5.0	–	6.5	–	ns
t _{ptoen}	B	14	Input to Output Enable	–	12.0	–	14.5	ns
t _{ptoedis}	C	15	Input to Output Disable	–	12.0	–	14.5	ns
t _{goeen}	B	16	Global OE Output Enable	–	6.0	–	7.0	ns
t _{goedis}	C	17	Global OE Output Disable	–	6.0	–	7.0	ns
t _{wh}	–	18	External Synchronous Clock Pulse Duration, High	3.0	–	4.0	–	ns
t _{wl}	–	19	External Synchronous Clock Pulse Duration, Low	3.0	–	4.0	–	ns

Table 2-0030B/2032VL

1. Unless noted otherwise, all parameters use a GRP load of 4, 20 PTXOR path, ORP and Y0 clock.
2. Standard 16-bit counter using GRP feedback.
3. Reference Switching Test Conditions section.

Internal Timing Parameters¹

Over Recommended Operating Conditions

PARAMETER	# ²	DESCRIPTION	-225		-180		UNITS
			MIN.	MAX.	MIN.	MAX.	
Inputs							
t_{io}	20	Input Buffer Delay	–	0.6	–	0.8	ns
t_{din}	21	Dedicated Input Delay	–	1.3	–	1.5	ns
GRP							
t_{grp}	22	GRP Delay	–	0.7	–	0.7	ns
GLB							
t_{4ptbpc}	23	4 Product Term Bypass Path Delay (Combinatorial)	–	1.2	–	1.8	ns
t_{4ptbpr}	24	4 Product Term Bypass Path Delay (Registered)	–	1.2	–	2.1	ns
t_{1ptxor}	25	1 Product Term/XOR Path Delay	–	2.2	–	3.1	ns
t_{20ptxor}	26	20 Product Term/XOR Path Delay	–	2.2	–	3.1	ns
t_{xoradj}	27	XOR Adjacent Path Delay ³	–	2.2	–	3.1	ns
t_{gbp}	28	GLB Register Bypass Delay	–	0.0	–	0.2	ns
t_{gsu}	29	GLB Register Setup Time before Clock	0.8	–	0.9	–	ns
t_{gh}	30	GLB Register Hold Time after Clock	1.7	–	2.1	–	ns
t_{gco}	31	GLB Register Clock to Output Delay	–	0.7	–	0.8	ns
t_{gro}	32	GLB Register Reset to Output Delay	–	1.3	–	1.3	ns
t_{ptre}	33	GLB Product Term Reset to Register Delay	–	3.2	–	4.0	ns
t_{ptoe}	34	GLB Product Term Output Enable to I/O Cell Delay	–	4.2	–	5.7	ns
t_{ptck}	35	GLB Product Term Clock Delay	0.5	2.8	1.4	3.6	ns
ORP							
t_{orp}	36	ORP Delay	–	1.3	–	1.4	ns
t_{orpbp}	37	ORP Bypass Delay	–	0.3	–	0.4	ns
Outputs							
t_{ob}	38	Output Buffer Delay	–	1.2	–	1.3	ns
t_{sl}	39	Output Slew Limited Delay Adder	–	2.0	–	2.0	ns
t_{oen}	40	I/O Cell OE to Output Enabled	–	1.5	–	2.8	ns
t_{odis}	41	I/O Cell OE to Output Disabled	–	1.5	–	2.8	ns
t_{goe}	42	Global Output Enable	–	2.0	–	2.2	ns
Clocks							
t_{gy0}	43	Clock Delay, Y0 to Global GLB Clock Line (Ref. clock)	–	0.8	1.5	1.5	ns
t_{gy1/2}	44	Clock Delay, Y1 or Y2 to Global GLB Clock Line	–	1.0	1.7	1.7	ns
Global Reset							
t_{gr}	45	Global Reset to GLB	–	2.2	–	3.0	ns

Table 2-0036A/2032VE

1. Internal Timing Parameters are not tested and are for reference only.
2. Refer to Timing Model in this data sheet for further details.
3. The XOR adjacent path can only be used by hard macros.

Internal Timing Parameters¹

Over Recommended Operating Conditions

PARAMETER	# ²	DESCRIPTION	-135		-110		UNITS
			MIN.	MAX.	MIN.	MAX.	
Inputs							
t _{io}	20	Input Buffer Delay	–	0.8	–	1.3	ns
t _{din}	21	Dedicated Input Delay	–	1.7	–	2.5	ns
GRP							
t _{grp}	22	GRP Delay	–	0.9	–	1.2	ns
GLB							
t _{4ptbpc}	23	4 Product Term Bypass Path Delay (Combinatorial)	–	3.9	–	4.8	ns
t _{4ptbpr}	24	4 Product Term Bypass Path Delay (Registered)	–	2.9	–	3.4	ns
t _{1ptxor}	25	1 Product Term/XOR Path Delay	–	4.4	–	5.4	ns
t _{20ptxor}	26	20 Product Term/XOR Path Delay	–	4.4	–	5.4	ns
t _{xoradj}	27	XOR Adjacent Path Delay ³	–	4.4	–	5.4	ns
t _{gbp}	28	GLB Register Bypass Delay	–	1.0	–	1.4	ns
t _{gsu}	29	GLB Register Setup Time before Clock	1.1	–	1.4	–	ns
t _{gh}	30	GLB Register Hold Time after Clock	2.9	–	4.1	–	ns
t _{gco}	31	GLB Register Clock to Output Delay	–	0.9	–	1.0	ns
t _{gro}	32	GLB Register Reset to Output Delay	–	1.8	–	2.7	ns
t _{ptre}	33	GLB Product Term Reset to Register Delay	–	6.1	–	7.1	ns
t _{ptoe}	34	GLB Product Term Output Enable to I/O Cell Delay	–	6.9	–	8.6	ns
t _{ptck}	35	GLB Product Term Clock Delay	1.7	4.1	2.5	4.4	ns
ORP							
t _{orp}	36	ORP Delay	–	1.5	–	1.9	ns
t _{orpbp}	37	ORP Bypass Delay	–	0.5	–	0.9	ns
Outputs							
t _{ob}	38	Output Buffer Delay	–	1.4	–	1.8	ns
t _{sl}	39	Output Slew Limited Delay Adder	–	2.0	–	2.0	ns
t _{oen}	40	I/O Cell OE to Output Enabled	–	3.4	–	3.4	ns
t _{odis}	41	I/O Cell OE to Output Disabled	–	3.4	–	3.4	ns
t _{goe}	42	Global Output Enable	–	2.6	–	3.6	ns
Clocks							
t _{gy0}	43	Clock Delay, Y0 to Global GLB Clock Line (Ref. clock)	1.7	1.7	1.8	1.8	ns
t _{gy1/2}	44	Clock Delay, Y1 or Y2 to Global GLB Clock Line	1.9	1.9	2.0	2.0	ns
Global Reset							
t _{gr}	45	Global Reset to GLB	–	5.3	–	7.1	ns

1. Internal Timing Parameters are not tested and are for reference only.
2. Refer to Timing Model in this data sheet for further details.
3. The XOR adjacent path can only be used by hard macros.

Table 2-0036A/2032VE

ispLSI 2032VE Timing Model

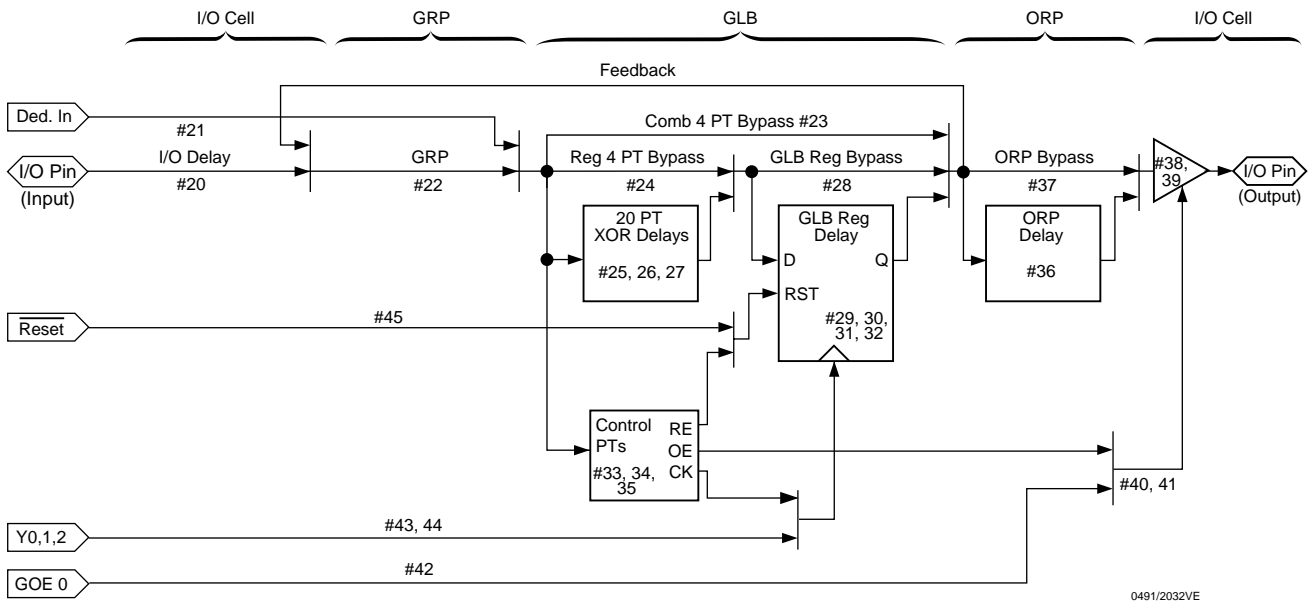

0491/2032VE

Derivations of tsu, th and tco from the Product Term Clock

$$\begin{aligned}
 \text{tsu} &= \text{Logic} + \text{Reg su} - \text{Clock (min)} \\
 &= (\text{tio} + \text{tgrp} + \text{t20ptxor}) + (\text{tgsu}) - (\text{tio} + \text{tgrp} + \text{tptck(min)}) \\
 &= (\#20 + \#22 + \#26) + (\#29) - (\#20 + \#22 + \#35) \\
 2.5\text{ns} &= (0.6 + 0.7 + 2.2) + (6.8) - (0.6 + 0.7 + 0.5) \\
 \text{th} &= \text{Clock (max)} + \text{Reg h} - \text{Logic} \\
 &= (\text{tio} + \text{tgrp} + \text{tptck(max)}) + (\text{tgh}) - (\text{tio} + \text{tgrp} + \text{t20ptxor}) \\
 &= (\#20 + \#22 + \#35) + (\#30) - (\#20 + \#22 + \#26) \\
 2.3\text{ns} &= (0.6 + 0.7 + 2.8) + (1.7) - (0.6 + 0.7 + 2.2) \\
 \text{tco} &= \text{Clock (max)} + \text{Reg co} + \text{Output} \\
 &= (\text{tio} + \text{tgrp} + \text{tptck(max)}) + (\text{tgco}) + (\text{torp} + \text{tob}) \\
 &= (\#20 + \#22 + \#35) + (\#31) + (\#36 + \#38) \\
 7.3\text{ns} &= (0.6 + 0.7 + 2.8) + (0.7) + (1.3 + 1.2)
 \end{aligned}$$

Note: Calculations are based on timing specifications for the ispLSI 2032VE-225L.

Table 2-0042/2032VE

Power Consumption

Power consumption in the ispLSI 2032VE device depends on two primary factors: the speed at which the device is operating and the number of product terms

used. Figure 3 shows the relationship between power and operating speed.

Figure 3. Typical Device Power Consumption vs fmax

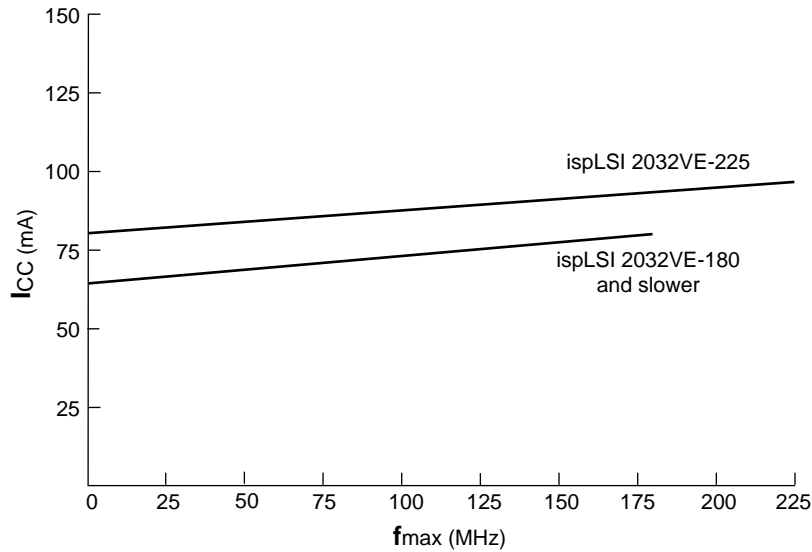

Notes: Configuration of two 16-bit counters
Typical current at 3.3V, 25° C

ICC can be estimated for the ispLSI 2032VE using the following equation:

For ispLSI 2032VE-225: $ICC(mA) = 4.5 + (\# \text{ of PTs} * 1.29) + (\# \text{ of nets} * \text{Max freq} * 0.0068)$

For ispLSI 2032VE-180 and slower: $ICC(mA) = 4.5 + (\# \text{ of PTs} * 1.05) + (\# \text{ of nets} * \text{Max freq} * 0.0068)$

Where:

- # of PTs = Number of product terms used in design
- # of nets = Number of signals used in device
- Max freq = Highest clock frequency to the device (in MHz)

The ICC estimate is based on typical conditions (VCC = 3.3V, room temperature) and an assumption of two GLB loads on average exists. These values are for estimates only. Since the value of ICC is sensitive to operating conditions and the program in the device, the actual ICC should be verified.

0127A/2032VE

Signal Descriptions

Signal Name	Description
GOE 0	Global Output Enable Pin
Y0	Dedicated Clock input. This clock input is connected to one of the clock inputs of all the GLBs on the device.
$\overline{\text{RESET}}/\text{Y1}$	This pin performs two functions: (1) Dedicated clock input. This clock input is brought into the Clock Deistribution Network and can optionally be routed to any GLB and/or I/O cell on the device. (2) Active Low (0) Reset pin which resets all of the GLB and I/O registers in the device.
$\overline{\text{BSCAN}}$	Input – Dedicated in-system programming Boundary Scan Enable input pin. This pin is brought low to enable the programming mode. The TMS, TDI, TDO and TCK controls become active.
TDI/IN 0	Input – This pin performs two functions. When $\overline{\text{BSCAN}}$ is logic low, it functions as an input pin to load programming data into the device. TDI/IN0 is also used as one of the two control pins for the ISP State Machine. When $\overline{\text{BSCAN}}$ is high, it functions as a dedicated input pin.
TMS/NC ¹	Input – When in ISP Mode, controls operation of the ISP State Machine.
TDO/IN 1	Output/Input – This pin performs two functions. When $\overline{\text{BSCAN}}$ is logic low, it functions as an output pin to read serial shift register data. When $\overline{\text{BSCAN}}$ is high, it functions as a dedicated input pin.
TCK/Y2	Input – This pin performs two functions. When $\overline{\text{BSCAN}}$ is logic low, it functions as a clock pin for the Serial Shift Register. When $\overline{\text{BSCAN}}$ is high, it functions as a dedicated clock input. This clock input is brought into the Clock Distribution Network and can optionally be routed to any GLB and/or I/O cell on the device.
GND	Ground (GND)
VCC	Vcc
NC ¹	No Connect
I/O	Input/Output pins – These are the general purpose I/O pins used by the logic array.

Signal Locations

Signal	44-Pin TQFP	44-Pin PLCC	48-Pin TQFP	49-Ball caBGA
GOE 0	40	2	43	A4
Y0	5	11	5	C1
$\overline{\text{RESET}}/\text{Y1}$	29	35	31	D7
$\overline{\text{BSCAN}}$	7	13	7	D1
TDI/IN 0	8	14	8	E2
TMS/NC ¹	30	36	32	C6
TDO/IN 1	18	24	19	G4
TCK/Y2	27	33	29	E7
GND	17, 39	1, 23	18, 42	C4, E4
VCC	6, 28	12, 34	6, 30	D3, D5
NC ¹	—	—	12, 24, 36, 48	A1, A7, D4, G1, G7

I/O Locations

Signal	44-Pin TQFP	44-Pin PLCC	48-Pin TQFP	49-Ball caBGA
I/O 0 - I/O 6	9, 10, 11, 12, 13, 14, 15	15, 16, 17, 18, 19, 20, 21	9, 10, 11, 13, 14, 15, 16	E1, F2, F1, E3, F3, G2, F4
I/O 7 - I/O 13	16, 19, 20, 21, 22, 23, 24	22, 25, 26, 27, 28, 29, 30	17, 20, 21, 22, 23, 25, 26	G3, F5, G5, F6, G6, E5, E6
I/O 14 - I/O 20	25, 26, 31, 32, 33, 34, 35	31, 32, 37, 38, 39, 40, 41	27, 28, 33, 34, 35, 37, 38	F7, D6, C7, B6, B7, C5, B5
I/O 21 - I/O 27	36, 37, 38, 41, 42, 43, 44	42, 43, 44, 3, 4, 5, 6	39, 40, 41, 44, 45, 46, 47	A6, B4, A5, B3, A3, B2, A2
I/O 28 - I/O 31	1, 2, 3, 4	7, 8, 9, 10	1, 2, 3, 4	C3, C2, B1, D2

1. NC pins are not to be connected to any active signals, VCC or GND.

Pin Configuration

ispLSI 2032VE 44-Pin TQFP Pinout Diagram

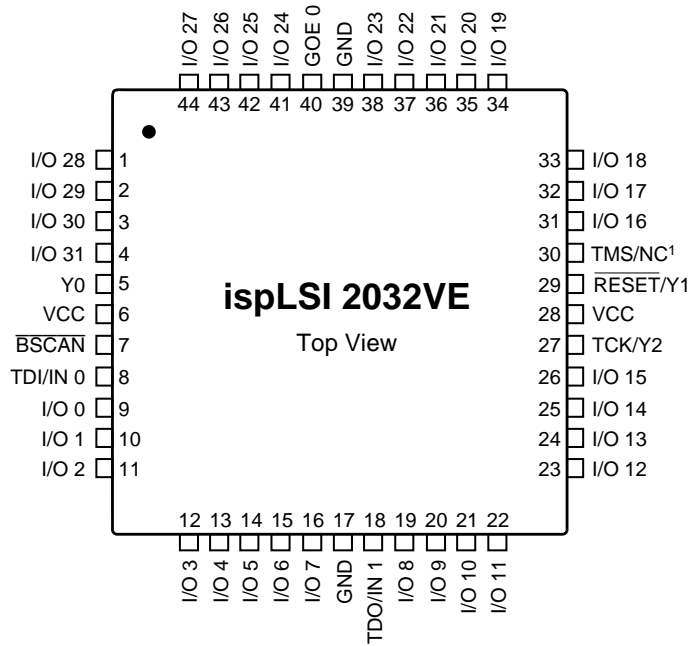

1. NC pins are not to be connected to any active signals, VCC or GND.

Pin Configuration

ispLSI 2032VE 44-Pin PLCC Pinout Diagram

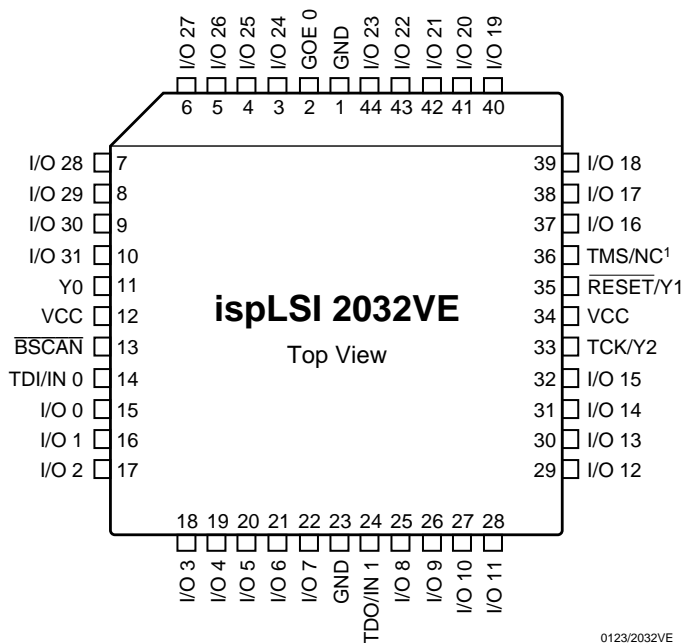

1. NC pins are not to be connected to any active signals, VCC or GND.

Pin Configuration

ispLSI 2032VE 48-Pin TQFP Pinout Diagram

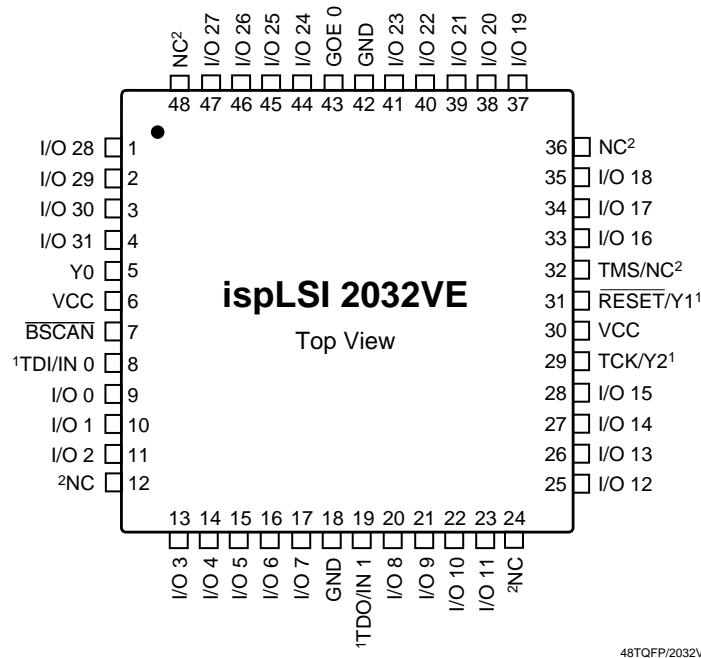

1. Pins have dual function capability.
2. NC pins are not to be connected to any active signals, V_{CC} or GND.

Signal Configuration

ispLSI 2032VE 49-Ball caBGA Signal Diagram

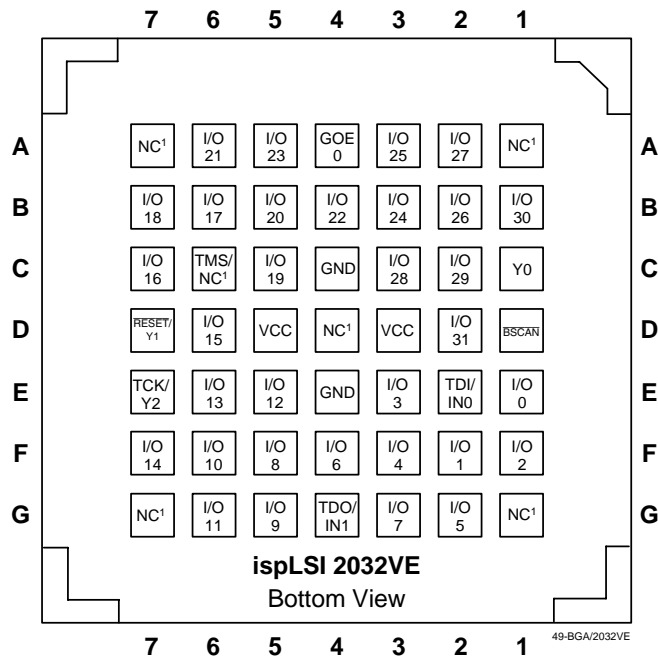

1. NCs are not to be connected to any active signals, V_{CC} or GND.
- Note: Ball A1 indicator dot on top side of package.

Part Number Description

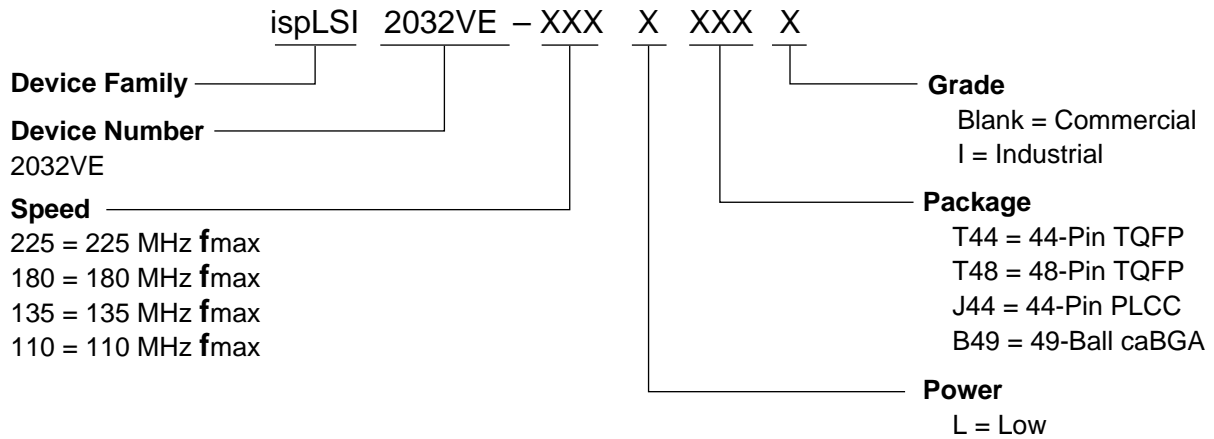

0212A/2032VE

ispLSI 2032VE Ordering Information

COMMERCIAL

FAMILY	fmax (MHz)	tpd (ns)	ORDERING NUMBER	PACKAGE
ispLSI	225	4.0	ispLSI 2032VE-225LT44	44-Pin TQFP
	225	4.0	ispLSI 2032VE-225LT48	48-Pin TQFP
	225	4.0	ispLSI 2032VE-225LJ44	44-Pin PLCC
	225	4.0	ispLSI 2032VE-225LB49	49-Ball caBGA
	180	5.0	ispLSI 2032VE-180LT44	44-Pin TQFP
	180	5.0	ispLSI 2032VE-180LT48	48-Pin TQFP
	180	5.0	ispLSI 2032VE-180LJ44	44-Pin PLCC
	180	5.0	ispLSI 2032VE-180LB49	49-Ball caBGA
	135	7.5	ispLSI 2032VE-135LT44	44-Pin TQFP
	135	7.5	ispLSI 2032VE-135LT48	48-Pin TQFP
	135	7.5	ispLSI 2032VE-135LJ44	44-Pin PLCC
	135	7.5	ispLSI 2032VE-135LB49	49-Ball caBGA
	110	10	ispLSI 2032VE-110LT44	44-Pin TQFP
	110	10	ispLSI 2032VE-110LT48	48-Pin TQFP
	110	10	ispLSI 2032VE-110LJ44	44-Pin PLCC
	110	10	ispLSI 2032VE-110LB49	49-Ball caBGA

Table 2-0041A/2032VE

INDUSTRIAL

FAMILY	fmax (MHz)	tpd (ns)	ORDERING NUMBER	PACKAGE
ispLSI	180	5.0	ispLSI 2032VE-180LT44I	44-Pin TQFP

Table 2-0041B/2032VE

This datasheet has been downloaded from:

www.DatasheetCatalog.com

Datasheets for electronic components.



LittleDiode supplies new, hard to find or obsolete electronic components and semiconductors all over the world.

With over two million different components listed you are sure to find the part you need.

Feel free to visit us today at our online store:

LittleDiode.com

Looking forward to providing you with the best possible service.