

Features

- **SUPERFAST HIGH DENSITY IN-SYSTEM PROGRAMMABLE LOGIC**
 - 4000 PLD Gates
 - 96 I/O Pins, Six Dedicated Inputs
 - 96 Registers
 - High Speed Global Interconnect
 - Wide Input Gating for Fast Counters, State Machines, Address Decoders, etc.
 - Small Logic Block Size for Random Logic
 - 100% Functional/JEDEC Upward Compatible with ispLSI 2096 Devices
- **HIGH PERFORMANCE E²CMOS[®] TECHNOLOGY**
 - $f_{max} = 180$ MHz Maximum Operating Frequency
 - $t_{pd} = 5.0$ ns Propagation Delay
 - TTL Compatible Inputs and Outputs
 - 5V Programmable Logic Core
 - ispJTAG[™] In-System Programmable via IEEE 1149.1 (JTAG) Test Access Port
 - User-Selectable 3.3V or 5V I/O Supports Mixed-Voltage Systems
 - PCI Compatible Outputs
 - Open-Drain Output Option
 - Electrically Erasable and Reprogrammable
 - Non-Volatile
 - Unused Product Term Shutdown Saves Power
- **ispLSI OFFERS THE FOLLOWING ADDED FEATURES**
 - Increased Manufacturing Yields, Reduced Time-to-Market and Improved Product Quality
 - Reprogram Soldered Devices for Faster Prototyping
- **OFFERS THE EASE OF USE AND FAST SYSTEM SPEED OF PLDs WITH THE DENSITY AND FLEXIBILITY OF FIELD PROGRAMMABLE GATE ARRAYS**
 - Complete Programmable Device Can Combine Glue Logic and Structured Designs
 - Enhanced Pin Locking Capability
 - Three Dedicated Clock Input Pins
 - Synchronous and Asynchronous Clocks
 - Programmable Output Slew Rate Control to Minimize Switching Noise
 - Flexible Pin Placement
 - Optimized Global Routing Pool Provides Global Interconnectivity
- **ispDesignEXPERT[™] – LOGIC COMPILER AND COMPLETE ISP DEVICE DESIGN SYSTEMS FROM HDL SYNTHESIS THROUGH IN-SYSTEM PROGRAMMING**
 - Superior Quality of Results
 - Tightly Integrated with Leading CAE Vendor Tools
 - Productivity Enhancing Timing Analyzer, Explore Tools, Timing Simulator and ispANALYZER[™]
 - PC and UNIX Platforms

Functional Block Diagram

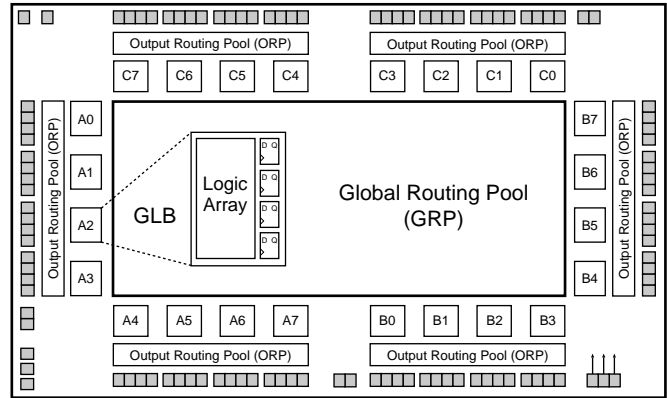

09192096E

Description

The ispLSI 2096E is a High Density Programmable Logic Device. The device contains 96 Registers, 96 Universal I/O pins, six Dedicated Input pins, three Dedicated Clock Input pins, two dedicated Global OE input pins and a Global Routing Pool (GRP). The GRP provides complete interconnectivity between all of these elements. The ispLSI 2096E features 5V in-system programmability and in-system diagnostic capabilities. The ispLSI 2096E offers non-volatile reprogrammability of all logic, as well as the interconnect to provide truly reconfigurable systems.

The basic unit of logic on the ispLSI 2096E device is the Generic Logic Block (GLB). The GLBs are labeled A0, A1 .. C7 (see Figure 1). There are a total of 24 GLBs in the ispLSI 2096E device. Each GLB is made up of four macrocells. Each GLB has 18 inputs, a programmable AND/OR/Exclusive OR array, and four outputs which can be configured to be either combinatorial or registered. Inputs to the GLB come from the GRP and dedicated inputs. All of the GLB outputs are brought back into the GRP so that they can be connected to the inputs of any GLB on the device.

The device also has 96 I/O cells, each of which is directly connected to an I/O pin. Each I/O cell can be individually programmed to be a combinatorial input, output or bi-directional I/O pin with 3-state control. The signal levels are TTL compatible voltages and the output drivers can source 4 mA or sink 8 mA. Each output can be programmed independently for fast or slow output slew rate to minimize overall output switching noise. By connecting

Functional Block Diagram

Figure 1. ispLSI 2096E Functional Block Diagram

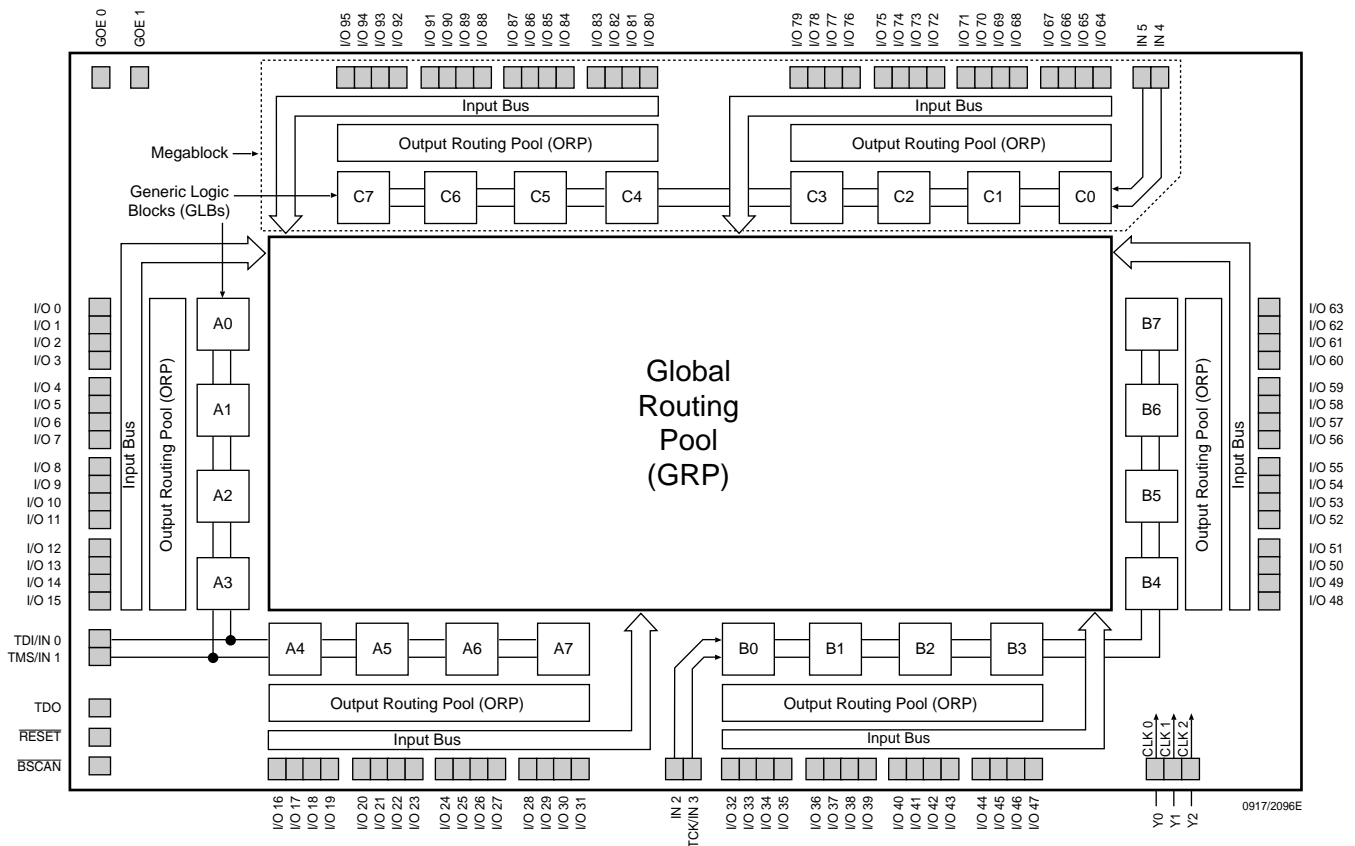

the VCCIO pins to a common 5V or 3.3V power supply, I/O output levels can be matched to 5V or 3.3V compatible voltages. When connected to a 5V supply, the I/O pins provide PCI-compatible output drive.

Eight GLBs, 32 I/O cells, two dedicated inputs and two ORPs are connected together to make a Megablock (see Figure 1). The outputs of the eight GLBs are connected to a set of 32 universal I/O cells by the two ORPs. Each ispLSI 2096E device contains three Megablocks.

The GRP has as its inputs, the outputs from all of the GLBs and all of the inputs from the bi-directional I/O cells. All of these signals are made available to the inputs of the GLBs. Delays through the GRP have been equalized to minimize timing skew.

Clocks in the ispLSI 2096E device are selected using the dedicated clock pins. Three dedicated clock pins (Y0, Y1, Y2) or an asynchronous clock can be selected on a GLB basis. The asynchronous or Product Term clock can be generated in any GLB for its own clock.

Programmable Open-Drain Outputs

In addition to the standard output configuration, the outputs of the ispLSI 2096E are individually programmable, either as a standard totem-pole output or an open-drain output. The totem-pole output drives the specified V_{oh} and V_{ol} levels, whereas the open-drain output drives only the specified V_{ol} . The V_{oh} level on the open-drain output depends on the external loading and pull-up. This output configuration is controlled by a programmable fuse. The default configuration when the device is in bulk erased state is totem-pole configuration. The open-drain/totem-pole option is selectable through the ispDesignEXPERT software tools.

Absolute Maximum Ratings ¹

Supply Voltage V_{CC} -0.5 to +7.0V
 Input Voltage Applied -2.5 to $V_{CC} + 1.0V$
 Off-State Output Voltage Applied -2.5 to $V_{CC} + 1.0V$
 Storage Temperature -65 to 150°C
 Case Temp. with Power Applied -55 to 125°C
 Max. Junction Temp. (T_J) with Power Applied ... 150°C

1. Stresses above those listed under the “Absolute Maximum Ratings” may cause permanent damage to the device. Functional operation of the device at these or at any other conditions above those indicated in the operational sections of this specification is not implied (while programming, follow the programming specifications).

DC Recommended Operating Condition

SYMBOL	PARAMETER	MIN.	MAX.	UNITS	
V_{CC}	Supply Voltage: Logic Core, Input Buffers $T_A = 0^\circ C$ to $+70^\circ C$	4.75	5.25	V	
V_{CCIO}	Supply Voltage: Output Drivers	5V	4.75	5.25	V
		3.3V	3.0	3.6	V
V_{IL}	Input Low Voltage	0	0.8	V	
V_{IH}	Input High Voltage	2.0	$V_{CC} + 1$	V	

Table 2-0005/2096E

Capacitance ($T_A = 25^\circ C$, $f = 1.0$ MHz)

SYMBOL	PARAMETER	TYP	UNITS	TEST CONDITIONS
C_1	Dedicated Input Capacitance	8	pf	$V_{CC} = 5.0V$, $V_{IN} = 2.0V$
C_2	I/O Capacitance	8	pf	$V_{CC} = 5.0V$, $V_{IO} = 2.0V$
C_3	Clock Capacitance	10	pf	$V_{CC} = 5.0V$, $V_Y = 2.0V$

Table 2-0006/2096E

Erase/Reprogram Specification

PARAMETER	MINIMUM	MAXIMUM	UNITS
Erase/Reprogram Cycles	10,000	–	Cycles

Table 2-0008/2096E

Switching Test Conditions

Input Pulse Levels	GND to 3.0V
Input Rise and Fall Time 10% to 90%	1.5 ns
Input Timing Reference Levels	1.5V
Output Timing Reference Levels	1.5V
Output Load	See Figure 2

3-state levels are measured 0.5V from steady-state active level.

Table 2-0003/2128E

Output Load Conditions (see Figure 2)

TEST CONDITION		R1	R2	CL
A		470Ω	390Ω	35pF
B	Active High	∞	390Ω	35pF
	Active Low	470Ω	390Ω	35pF
C	Active High to Z at $V_{OH} - 0.5V$	∞	390Ω	5pF
	Active Low to Z at $V_{OL} + 0.5V$	470Ω	390Ω	5pF

Table 2 - 0004A/2000

Figure 2. Test Load

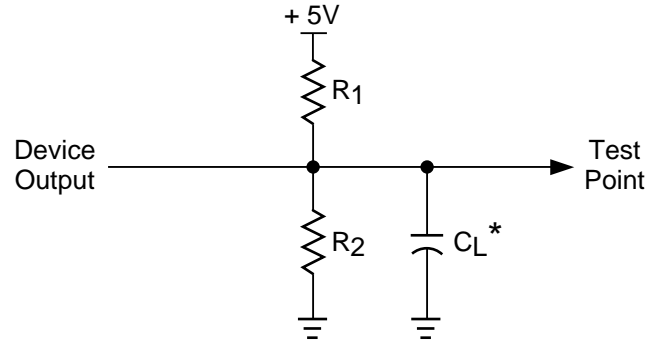

* C_L includes Test Fixture and Probe Capacitance.

0213A

DC Electrical Characteristics

Over Recommended Operating Conditions

SYMBOL	PARAMETER	CONDITION	MIN.	TYP. ³	MAX.	UNITS
V_{OL}	Output Low Voltage	$I_{OL} = 8 \text{ mA}$	–	–	0.4	V
V_{OH}	Output High Voltage	$I_{OH} = -4 \text{ mA}$	2.4	–	–	V
I_{IL}	Input or I/O Low Leakage Current	$0V \leq V_{IN} \leq V_{IL} (\text{Max.})$	–	–	-10	μA
I_{IH}	Input or I/O High Leakage Current	$(V_{CCIO} - 0.2)V \leq V_{IN} \leq V_{CCIO}$	–	–	10	μA
		$V_{CCIO} \leq V_{IN} \leq 5.25V$	–	–	10	μA
I_{IL-PU}	I/O Active Pull-Up Current	$0V \leq V_{IN} \leq 2.0V$	-10	–	-250	μA
I_{OS}^1	Output Short Circuit Current	$V_{CCIO} = 5.0V \text{ or } 3.3V, V_{OUT} = 0.5V$	–	–	-240	mA
$I_{CC}^{3,4}$	Operating Power Supply Current	$V_{IL} = 0.0V, V_{IH} = 3.0V$ $f_{TOGGLE} = 1 \text{ MHz}$	–	130	–	mA

Table 2-0007/2096E

- One output at a time for a maximum duration of one second. $V_{OUT} = 0.5V$ was selected to avoid test problems by tester ground degradation. Characterized but not 100% tested.
- Measured using six 16-bit counters.
- Typical values are at $V_{CC} = 5V$ and $T_A = 25^\circ\text{C}$.
- Unused inputs held at 0.0V.
- Maximum I_{CC} varies widely with specific device configuration and operating frequency. Refer to the Power Consumption section of this data sheet and the Thermal Management section of the Lattice Semiconductor Data Book or CD-ROM to estimate maximum I_{CC} .

External Timing Parameters

Over Recommended Operating Conditions

PARAMETER	TEST COND. ⁴	# ²	DESCRIPTION ¹	-180		-135		-100		UNITS
				MIN.	MAX.	MIN.	MAX.	MIN.	MAX.	
t _{pd1}	A	1	Data Prop Delay, 4PT Bypass, ORP Bypass	–	5.0	–	7.5	–	10.0	ns
t _{pd2}	A	2	Data Prop Delay	–	7.5	–	10.0	–	13.0	ns
f _{max}	A	3	Clk Freq with Internal Feedback ³	180	–	135	–	100	–	MHz
f _{max} (Ext.)	–	4	Clk Freq with External Feedback ($\frac{1}{t_{su2} + t_{co1}}$)	125	–	100	–	77	–	MHz
f _{max} (Tog.)	–	5	Clk Frequency, Max. Toggle	200	–	143	–	100	–	MHz
t _{su1}	–	6	GLB Reg Setup Time before Clk, 4 PT Bypass	4.0	–	5.0	–	6.5	–	ns
t _{co1}	A	7	GLB Reg Clk to Output Delay, ORP Bypass	–	3.0	–	4.0	–	5.0	ns
t _{h1}	–	8	GLB Reg Hold Time after Clk, 4 PT Bypass	0.0	–	0.0	–	0.0	–	ns
t _{su2}	–	9	GLB Reg Setup Time before Clk	5.0	–	6.0	–	8.0	–	ns
t _{co2}	–	10	GLB Reg Clk to Output Delay	–	3.5	–	4.5	–	6.0	ns
t _{h2}	–	11	GLB Reg Hold Time after Clk	0.0	–	0.0	–	0.0	–	ns
t _{r1}	A	12	External Reset Pin to Output Delay	–	7.0	–	10.0	–	13.5	ns
t _{rw1}	–	13	External Reset Pulse Duration	4.0	–	5.0	–	6.5	–	ns
t _{ptoen}	B	14	Input to Output Enable	–	10.0	–	12.0	–	15.0	ns
t _{ptodis}	C	15	Input to Output Disable	–	10.0	–	12.0	–	15.0	ns
t _{goeen}	B	16	Global OE Output Enable	–	5.0	–	7.0	–	9.0	ns
t _{goedis}	C	17	Global OE Output Disable	–	5.0	–	7.0	–	9.0	ns
t _{wh}	–	18	External Synch Clk Pulse Duration, High	2.5	–	3.5	–	5.0	–	ns
t _{wl}	–	19	External Synch Clk Pulse Duration, Low	2.5	–	3.5	–	5.0	–	ns

Table 2-0030A/2096E

1. Unless noted otherwise, all parameters use a GRP load of four GLBs, 20 PTXOR path, ORP and Y0 clock.
2. Refer to Timing Model in this data sheet for further details.
3. Standard 16-bit counter using GRP feedback.
4. Reference Switching Test Conditions section.

Internal Timing Parameters¹

Over Recommended Operating Conditions

PARAMETER	# ²	DESCRIPTION	-180		-135		-100		UNITS
			MIN.	MAX.	MIN.	MAX.	MIN.	MAX.	
Inputs									
t_{io}	20	Input Buffer Delay	–	0.5	–	0.5	–	0.5	ns
t_{din}	21	Dedicated Input Delay	–	1.1	–	1.7	–	2.2	ns
GRP									
t_{grp}	22	GRP Delay	–	0.6	–	1.2	–	1.7	ns
GLB									
t_{4ptbpc}	23	4 Product Term Bypass Path Delay (Combinatorial)	–	1.9	–	3.7	–	5.8	ns
t_{4ptbpr}	24	4 Product Term Bypass Path Delay (Registered)	–	2.9	–	4.2	–	5.8	ns
t_{1ptxor}	25	1 Product Term/XOR Path Delay	–	3.9	–	5.2	–	6.8	ns
t_{20ptxor}	26	20 Product Term/XOR Path Delay	–	3.9	–	5.2	–	7.3	ns
t_{xoradj}	27	XOR Adjacent Path Delay ³	–	3.9	–	5.2	–	8.0	ns
t_{gbp}	28	GLB Register Bypass Delay	–	0.0	–	0.5	–	0.5	ns
t_{gsu}	29	GLB Register Setup Time before Clock	0.7	–	0.7	–	1.2	–	ns
t_{gh}	30	GLB Register Hold Time after Clock	3.3	–	4.3	–	4.0	–	ns
t_{gco}	31	GLB Register Clock to Output Delay	–	0.3	–	0.3	–	0.3	ns
t_{gro}	32	GLB Register Reset to Output Delay	–	0.6	–	1.1	–	1.3	ns
t_{ptre}	33	GLB Product Term Reset to Register Delay	–	4.8	–	6.0	–	6.1	ns
t_{ptoe}	34	GLB Product Term Output Enable to I/O Cell Delay	–	5.9	–	6.9	–	8.6	ns
t_{ptck}	35	GLB Product Term Clock Delay	1.0	4.0	2.5	5.5	4.1	7.1	ns
ORP									
t_{orp}	36	ORP Delay	–	0.9	–	1.0	–	1.4	ns
t_{orpbp}	37	ORP Bypass Delay	–	0.4	–	0.5	–	0.4	ns
Outputs									
t_{ob}	38	Output Buffer Delay	–	1.6	–	1.6	–	1.6	ns
t_{sl}	39	Output Slew Limited Delay Adder	–	1.5	–	1.5	–	1.0	ns
t_{oen}	40	I/O Cell OE to Output Enabled	–	3.0	–	3.4	–	4.2	ns
t_{odis}	41	I/O Cell OE to Output Disabled	–	3.0	–	3.4	–	4.2	ns
t_{goe}	42	Global Output Enable	–	2.0	–	3.6	–	4.8	ns
Clocks									
t_{gy0}	43	Clock Delay, Y0 to Global GLB Clock Line (Ref. clock)	0.7	0.7	1.6	1.6	2.7	2.7	ns
t_{gy1/2}	44	Clock Delay, Y1 or Y2 to Global GLB Clock Line	0.9	0.9	1.8	1.8	2.7	2.7	ns
Global Reset									
t_{gr}	45	Global Reset to GLB	–	4.4	–	6.3	–	9.2	ns

Table 2-0036A/2096E

1. Internal Timing Parameters are not tested and are for reference only.
2. Refer to Timing Model in this data sheet for further details.
3. The XOR adjacent path can only be used by hard macros.

ispLSI 2096E Timing Model

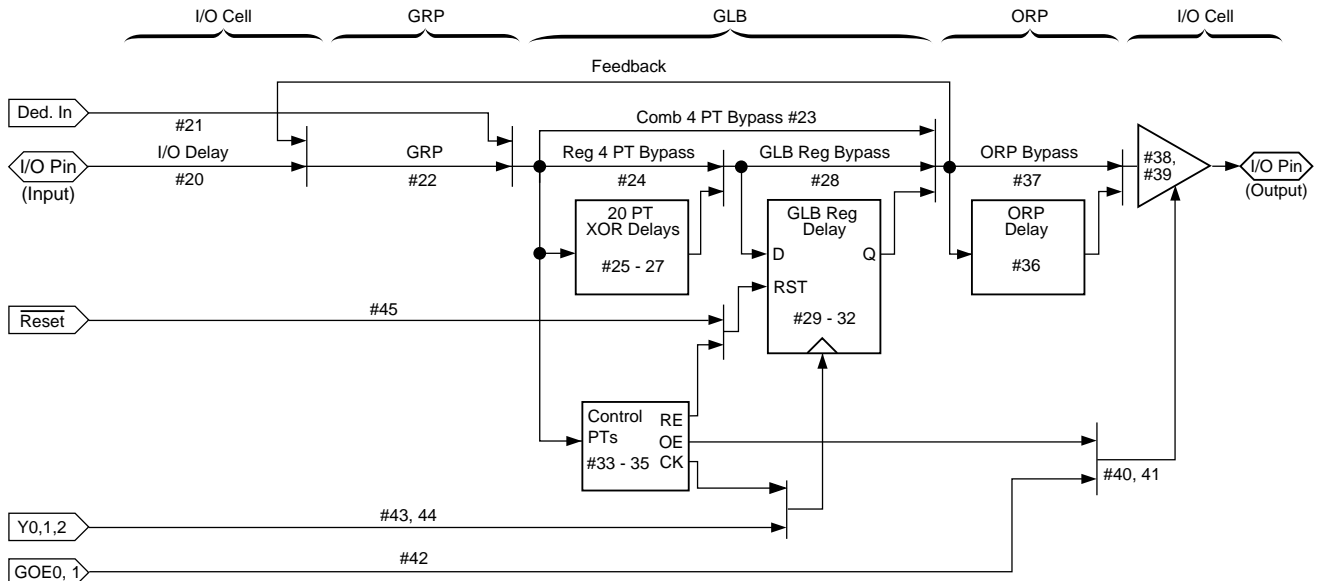

0491/2096E

Derivations of t_{su} , t_h and t_{co} from the Product Term Clock

$$\begin{aligned}
 t_{su} &= \text{Logic} + \text{Reg } s_u - \text{Clock (min)} \\
 &= (t_{io} + t_{grp} + t_{20ptxor}) + (t_{gsu}) - (t_{io} + t_{grp} + t_{ptck(min)}) \\
 &= (\#20 + \#22 + \#26) + (\#29) - (\#20 + \#22 + \#35) \\
 3.6 &= (0.5 + 0.6 + 3.9) + (0.7) - (0.5 + 0.6 + 1.0)
 \end{aligned}$$

$$\begin{aligned}
 t_h &= \text{Clock (max)} + \text{Reg } h - \text{Logic} \\
 &= (t_{io} + t_{grp} + t_{ptck(max)}) + (t_{gh}) - (t_{io} + t_{grp} + t_{20ptxor}) \\
 &= (\#20 + \#22 + \#35) + (\#30) - (\#20 + \#22 + \#26) \\
 3.4 &= (0.5 + 0.6 + 4.0) + (3.3) - (0.5 + 0.6 + 3.9)
 \end{aligned}$$

$$\begin{aligned}
 t_{co} &= \text{Clock (max)} + \text{Reg } c_o + \text{Output} \\
 &= (t_{io} + t_{grp} + t_{ptck(max)}) + (t_{gco}) + (t_{orp} + t_{ob}) \\
 &= (\#20 + \#22 + \#35) + (\#31) + (\#36 + \#38) \\
 7.9 &= (0.5 + 0.6 + 4.0) + (0.3) + (0.9 + 1.6)
 \end{aligned}$$

Table 2-0042/2096E

Note: Calculations are based upon timing specifications for the ispLSI 2096E-180L.

Power Consumption

Power consumption in the ispLSI 2096E device depends on two primary factors: the speed at which the device is operating and the number of Product Terms used.

Figure 3 shows the relationship between power and operating speed.

Figure 3. Typical Device Power Consumption vs fmax

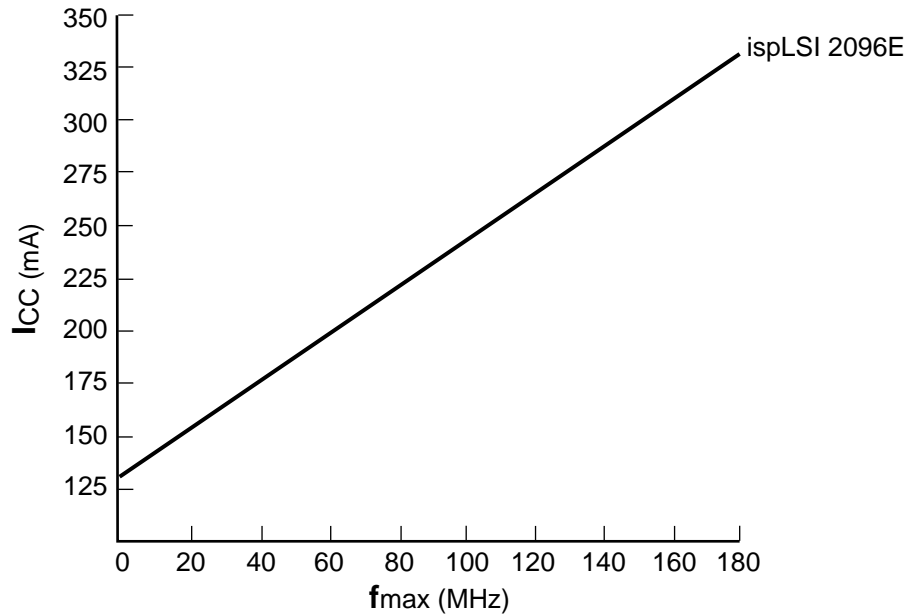

Notes: Configuration of six 16-bit counters
Typical current at 5V, 25° C

ICC can be estimated for the ispLSI 2096E using the following equation:

$$I_{CC} = 5.5 + (\# \text{ of PTs} * 0.67) + (\# \text{ of nets} * \text{max freq} * 0.0047)$$

Where:

- # of PTs = Number of Product Terms used in design
- # of nets = Number of Signals used in device
- Max freq = Highest Clock Frequency to the device (in MHz)

The ICC estimate is based on typical conditions (VCC = 5.0V, room temperature) and an assumption of two GLB loads on average exists. These values are for estimates only. Since the value of ICC is sensitive to operating conditions and the program in the device, the actual ICC should be verified.

0127/2096E

Pin Description

NAME	PQFP & TQFP PIN NUMBERS	DESCRIPTION
I/O 0 - I/O 5 I/O 6 - I/O 11 I/O 12 - I/O 17 I/O 18 - I/O 23 I/O 24 - I/O 29 I/O 30 - I/O 35 I/O 36 - I/O 41 I/O 42 - I/O 47 I/O 48 - I/O 53 I/O 54 - I/O 59 I/O 60 - I/O 65 I/O 66 - I/O 71 I/O 72 - I/O 77 I/O 78 - I/O 83 I/O 84 - I/O 89 I/O 90 - I/O 95	21, 22, 23, 24, 25, 26 27, 28, 29, 30, 31, 32 34, 35, 36, 37, 38, 39 40, 41, 42, 43, 44, 45 52, 53, 54, 55, 56, 57 58, 59, 60, 61, 62, 63 66, 67, 68, 69, 70, 71 72, 73, 74, 75, 76, 77 85, 86, 87, 88, 89, 90 91, 92, 93, 94, 95, 96 98, 99, 100, 101, 102, 103 104, 105, 106, 107, 108, 109 117, 118, 119, 120, 121, 122 123, 124, 125, 126, 127, 128 2, 3, 4, 5, 6, 7 8, 9, 10, 11, 12, 13	Input/Output Pins - These are the general purpose I/O pins used by the logic array.
GOE 0, GOE 1	64, 114	Global Output Enables input pins.
IN 2, IN 4, IN 5	51, 84, 110	Dedicated input pins to the device.
$\overline{\text{BSCAN}}$	18	Input - Dedicated in-system programming enable input pin. This pin is brought low to enable the programming mode. The TMS, TDI, TDO and TCK options become active.
TDI/IN 0 ¹	20	Input - This pin performs two functions. When $\overline{\text{BSCAN}}$ is logic low, it functions as an input pin to load programming data into the device. TDI/IN0 also is used as one of the two control pins for the isp state machine. When $\overline{\text{BSCAN}}$ is high, it functions as a dedicated input pin.
TMS/IN 1 ¹	46	Input - This pin performs two functions. When $\overline{\text{BSCAN}}$ is logic low, it functions as a pin to control the operation of the isp state machine. When $\overline{\text{BSCAN}}$ is high, it functions as a dedicated input pin.
TDO ¹	50	Output - When $\overline{\text{BSCAN}}$ is logic low, it functions as an output pin to read serial shift register data.
TCK/IN 3 ¹	78	Input - This pin performs two functions. When $\overline{\text{BSCAN}}$ is logic low, it functions as a clock pin for the Serial Shift Register. When $\overline{\text{BSCAN}}$ is high, it functions as a dedicated input pin.
$\overline{\text{RESET}}$	19	Active Low (0) Reset pin which resets all of the GLB and I/O registers in the device.
Y0, Y1, Y2	15, 83, 80	Dedicated Clock input. This clock input is connected to one of the clock inputs of all the GLBs on the device.
GND	1, 17, 33, 49, 65, 81, 97, 112, 115, 116	Ground (GND)
VCC	16, 48, 82, 113	V _{CC}
VCCIO	14, 47, 79, 111	Supply voltage for output drivers, 5V or 3.3V. All VCCIO pins must be connected to the same voltage level

1. Pins have dual function capability.

Pin Configuration

ispLSI 2096E 128-pin PQFP and TQFP Pinout Diagram

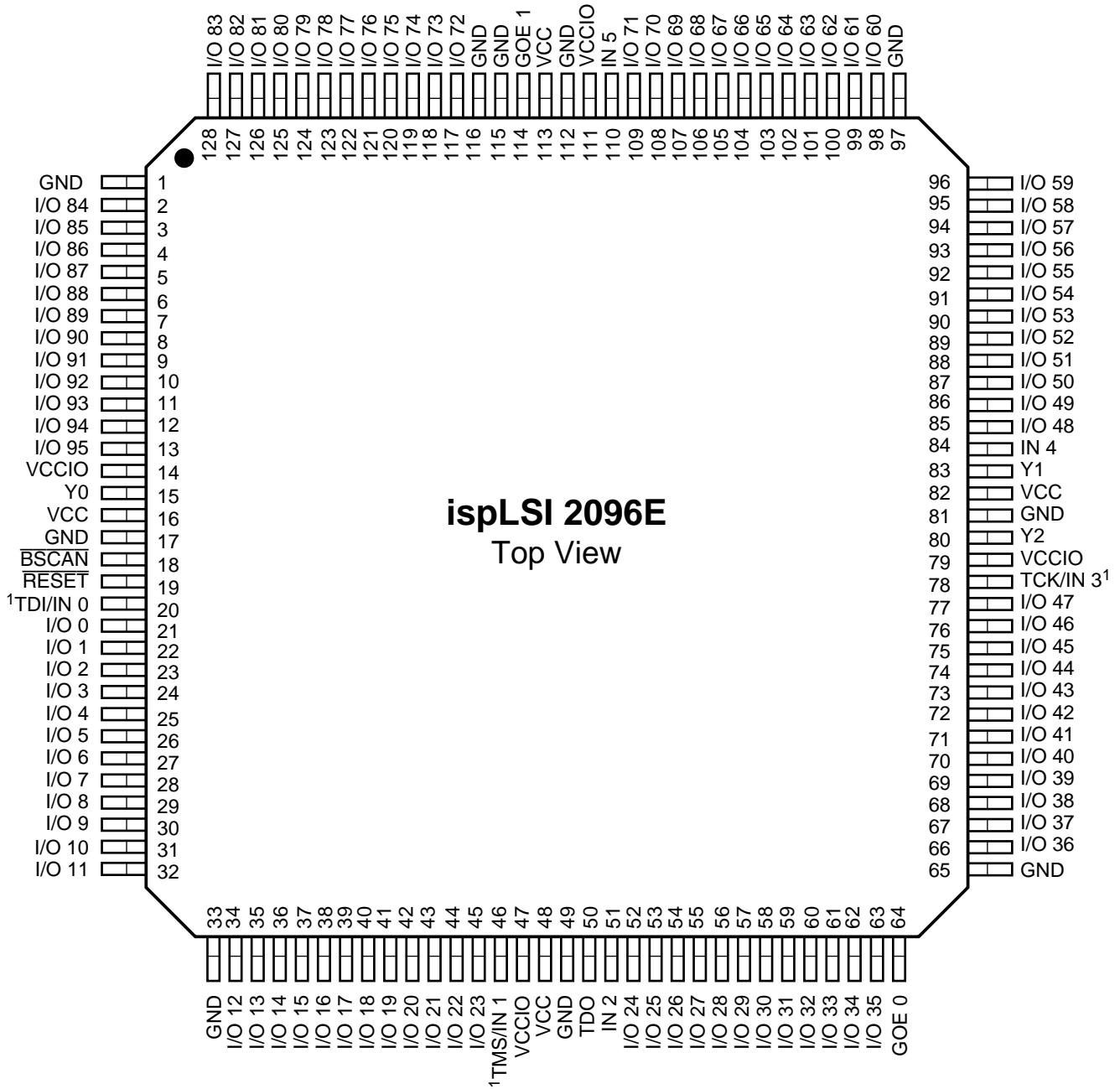

1. Pins have dual function capability.

Part Number Description

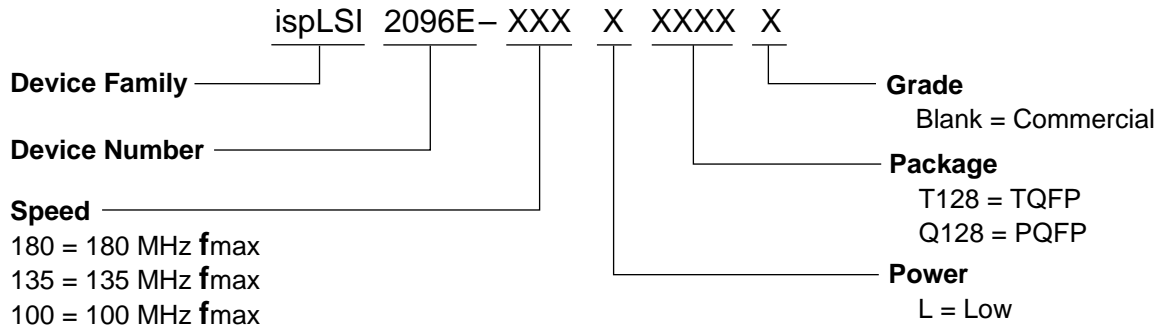

0212/2096E

ispLSI 2096E Ordering Information

FAMILY	f _{max} (MHz)	t _{pd} (ns)	ORDERING NUMBER	PACKAGE
ispLSI	180	5.0	ispLSI 2096E-180LT128	128-Pin TQFP
	180	5.0	ispLSI 2096E-180LQ128	128-Pin PQFP
	135	7.5	ispLSI 2096E-135LT128	128-Pin TQFP
	135	7.5	ispLSI 2096E-135LQ128	128-Pin PQFP
	100	10.0	ispLSI 2096E-100LT128	128-Pin TQFP
	100	10.0	ispLSI 2096E-100LQ128	128-Pin PQFP

Table 2-0041/2096E

This datasheet has been downloaded from:

www.DatasheetCatalog.com

Datasheets for electronic components.



LittleDiode supplies new, hard to find or obsolete electronic components and semiconductors all over the world.

With over two million different components listed you are sure to find the part you need.

Feel free to visit us today at our online store:

LittleDiode.com

Looking forward to providing you with the best possible service.