

BU208A

Horizontal Deflection Transistor

... designed for use in televisions.

- Collector–Emitter Voltages V_{CES} 1500 Volts
- Fast Switching — 400 ns Typical Fall Time
- Low Thermal Resistance 1°C/W Increased Reliability
- Glass Passivated (Patented Photoglass). Triple Diffused Mesa Technology for Long Term Stability

**5.0 AMPERES
NPN SILICON
POWER TRANSISTOR
700 VOLTS**

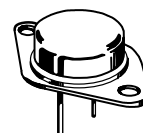

**CASE 1-07
TO-204AA
(TO-3)**

MAXIMUM RATINGS

Rating	Symbol	BU208A	Unit
Collector–Emitter Voltage	$V_{CEO(sus)}$	700	Vdc
Collector–Emitter Voltage	V_{CES}	1500	Vdc
Emitter–Base Voltage	V_{EB}	5.0	Vdc
Collector Current — Continuous	I_C	5.0	Vdc
— Peak	I_{CM}	7.5	
Base Current — Continuous	I_B	4.0	Adc
— Peak (Negative)	I_{BM}	3.5	
Total Power Dissipation @ $T_C = 95^\circ\text{C}$	P_D	12.5	Watts
Derate above 95°C		0.625	W/°C
Operating and Storage Junction Temperature Range	T_J, T_{stg}	-65 to +115	°C

THERMAL CHARACTERISTICS

Characteristic	Symbol	Max	Unit
Thermal Resistance, Junction to Case	$R_{\theta JC}$	1.6	°C/W
Maximum Lead Temperature for Soldering Purpose, 1/8" from Case for 5 Seconds	T_L	275	°C

NOTES:

1. Pulsed 5.0 ms, Duty Cycle \leq 10%.
2. See page 3 for Additional Ratings on A Type.
3. Figures in () are Standard Ratings Motorola Guarantees are Superior.

BU208A**ELECTRICAL CHARACTERISTICS** ($T_C = 25^\circ\text{C}$ unless otherwise noted)

Characteristic	Symbol	Min	Typ	Max	Unit
OFF CHARACTERISTICS					
Collector–Emitter Sustaining Voltage ($I_C = 100\text{ mA}$, $L = 25\text{ mH}$)	$V_{CE(sus)}$	700	—	—	Vdc
Collector Cutoff Current ¹ ($V_{CE} = \text{rated } V_{CES}$, $V_{BE} = 0$)	I_{CES}	—	—	1.0	mA
Emitter Base Voltage ¹ ($I_C = 0$, $I_E = 10\text{ mA}$) ($I_C = 0$, $I_E = 100\text{ mA}$)	V_{EBO}	5 —	— 7	— —	Vdc
ON CHARACTERISTICS¹					
DC Current Gain ($I_C = 4.5\text{ A}$, $V_{CE} = 5\text{ V}$)	h_{FE}	2.25	—	—	
Collector–Emitter Saturation Voltage ($I_C = 4.5\text{ A}$, $I_B = 2\text{ A}$)	$V_{CE(sat)}$	—	—	1	Vdc
Base–Emitter Saturation Voltage ($I_C = 4.5\text{ A}$, $I_B = 2\text{ A}$)	$V_{BE(sat)}$	—	—	1.5	Vdc
DYNAMIC CHARACTERISTICS					
Current–Gain Bandwidth Product ($I_C = 0.1\text{ A}$, $V_{CE} = 5\text{ V}$, $f_{test} = 1\text{ MHz}$)	f_T	—	4	—	MHz
Output Capacitance ($V_{CB} = 10\text{ V}$, $I_E = 0$, $f_{test} = 1\text{ MHz}$)	C_{ob}	—	125	—	pF
SWITCHING CHARACTERISTICS					
Storage Time (see test circuit fig. 1) ($I_C = 4.5\text{ A}$, $I_{B1} = 1.8\text{ A}$, $L_B = 10\text{ }\mu\text{H}$)	t_s	—	8	—	μs
Fall time (see test circuit fig. 1) ($I_C = 4.5\text{ A}$, $I_{B1} = 1.8\text{ A}$, $L_B = 10\text{ }\mu\text{H}$)	t_f	—	0.4	—	μs

¹Pulse test: $PW = 300\text{ }\mu\text{s}$; Duty cycle $\leq 2\%$.

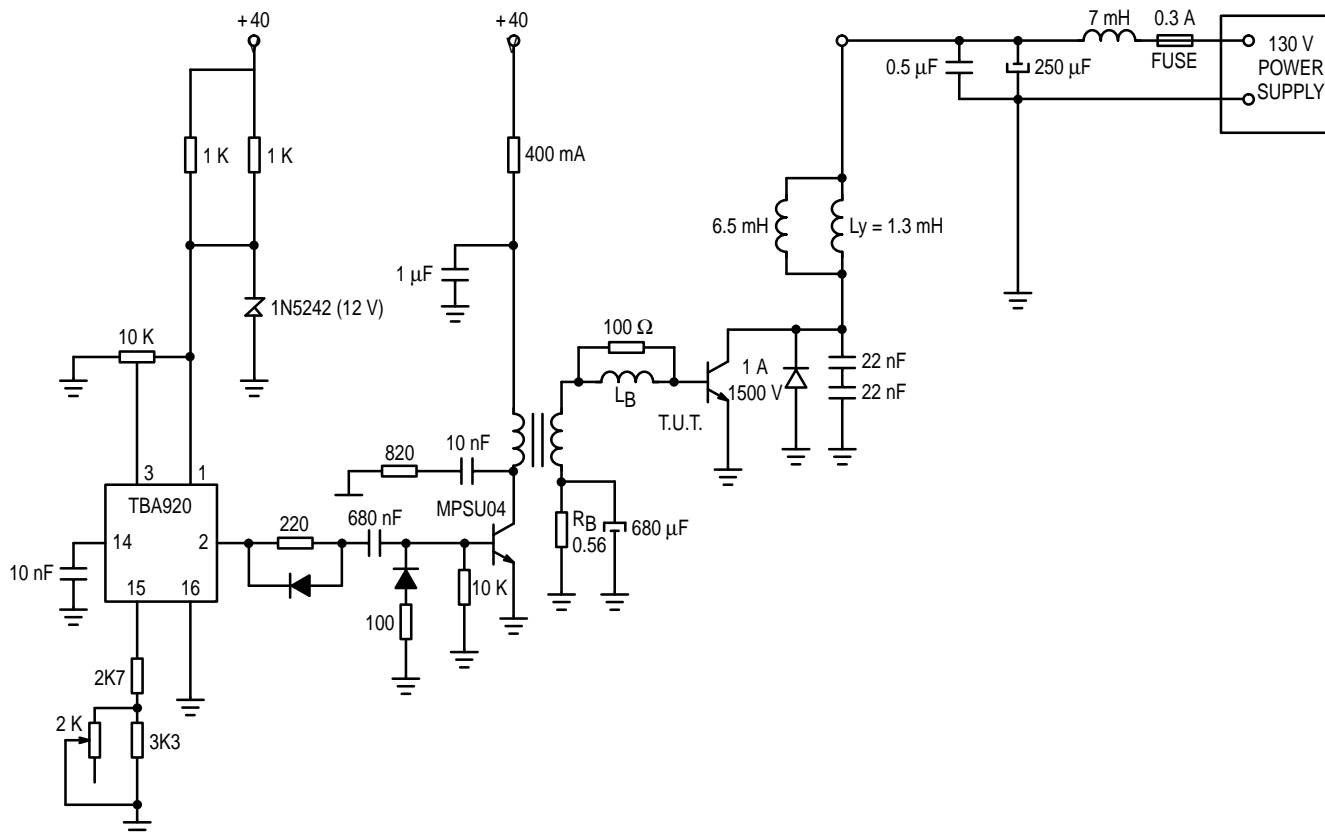

Figure 1. Switching Time Test Circuit

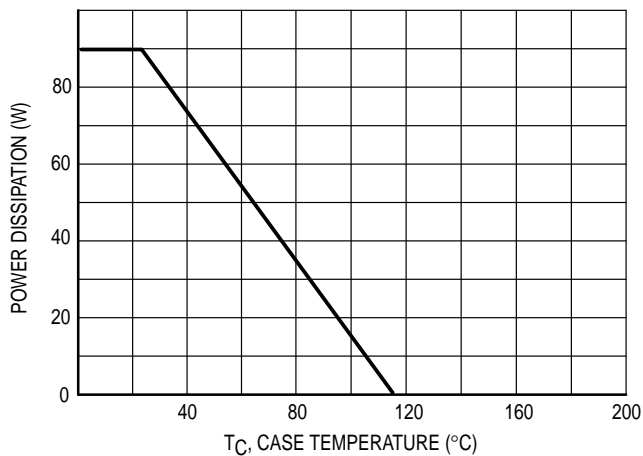

Figure 2. Power Derating

BASE DRIVE
The Key to Performance

By now, the concept of controlling the shape of the turn-off base current is widely accepted and applied in horizontal deflection design. The problem stems from the fact that good saturation of the output device, prior to turn-off, must be assured. This is accomplished by providing more than enough I_{B1} to satisfy the lowest gain output device h_{FE} at the end of scan I_{CM} . Worst-case component variations and maximum high voltage loading must also be taken into account.

If the base of the output transistor is driven by a very low impedance source, the turn-off base current will reverse very quickly as shown in Fig. 3. This results in rapid, but only partial collector turn-off, because excess carriers become trapped in the high resistivity collector and the transistor is still conductive. This is a high dissipation mode, since the collector voltage is rising very rapidly. The problem is overcome by adding inductance to the base circuit to slow the base current reversal as shown in Fig. 4, thus allowing access carrier recombination in the collector to occur while the base current is still flowing.

Choosing the right L_B is usually done empirically since the equivalent circuit is complex, and since there are several important variables (I_{CM} , I_{B1} , and h_{FE} at I_{CM}). One method is to plot fall time as a function of L_B , at the desired conditions, for several devices within the h_{FE} specification. A more informative method is to plot power dissipation versus I_{B1} for a range of values of L_B .

This shows the parameter that really matters, dissipation, whether caused by switching or by saturation. For very low L_B a very narrow optimum is obtained. This occurs when $I_{B1} h_{FE} \cong I_{CM}$, and therefore would be acceptable only for the "typical" device with constant I_{CM} . As L_B is increased, the curves become broader and flatter above the $I_{B1} h_{FE} = I_{CM}$ point as the turn off "tails" are brought under control. Eventually, if L_B is raised too far, the dissipation all across the curve will rise, due to poor initiation of switching rather than tailing. Plotting this type of curve family for devices of different h_{FE} , essentially moves the curves to the left, or right according to the relation $I_{B1} h_{FE} = \text{constant}$. It then becomes obvious that, for a specified I_{CM} , an L_B can be chosen which will give low dissipation over a range of h_{FE} and/or I_{B1} . The only remaining decision is to pick I_{B1} high enough to accommodate the lowest h_{FE} part specified. Neither L_B nor I_{B1} are absolutely critical. Due to the high gain of Motorola devices it is suggested that in general a low value of I_{B1} be used to obtain optimum efficiency — eg. for BU208A with $I_{CM} = 4.5$ A use $I_{B1} \approx 1.5$ A, at $I_{CM} = 4$ A use $I_{B1} \approx 1.2$ A. These values are lower than for most competition devices but practical tests have showed comparable efficiency for Motorola devices even at the higher level of I_{B1} .

An L_B of 10 μH to 12 μH should give satisfactory operation of BU208A with I_{CM} of 4 to 4.5 A and I_{B1} between 1.2 and 2 A.

TEST CIRCUIT WAVEFORMS

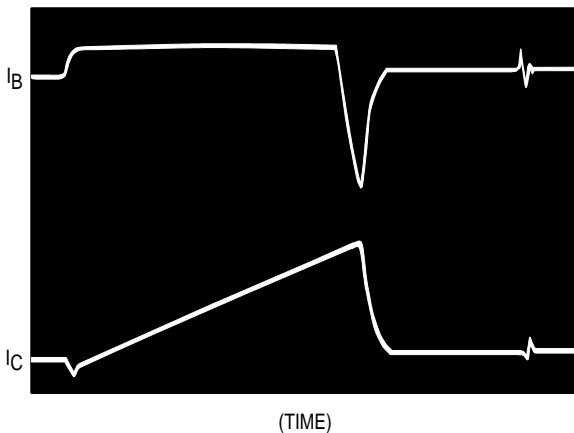

Figure 3

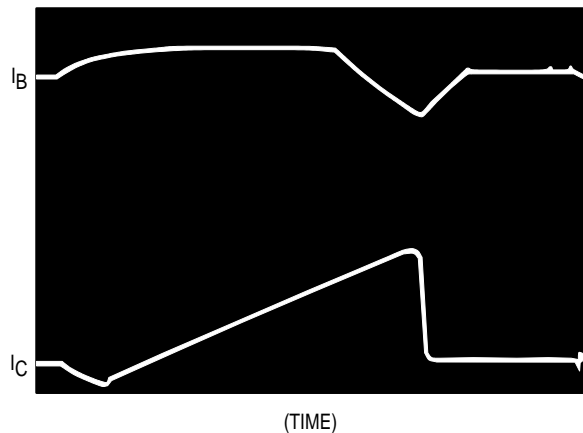

Figure 4

TEST CIRCUIT OPTIMIZATION

The test circuit may be used to evaluate devices in the conventional manner, i.e., to measure fall time, storage time, and saturation voltage. However, this circuit was designed to evaluate devices by a simple criterion, power supply input.

Excessive power input can be caused by a variety of problems, but it is the dissipation in the transistor that is of fundamental importance. Once the required transistor operating current is determined, fixed circuit values may be selected.

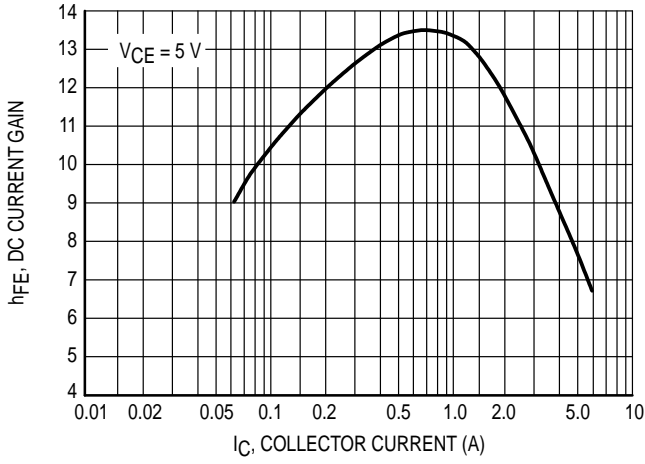

Figure 5. DC Current Gain

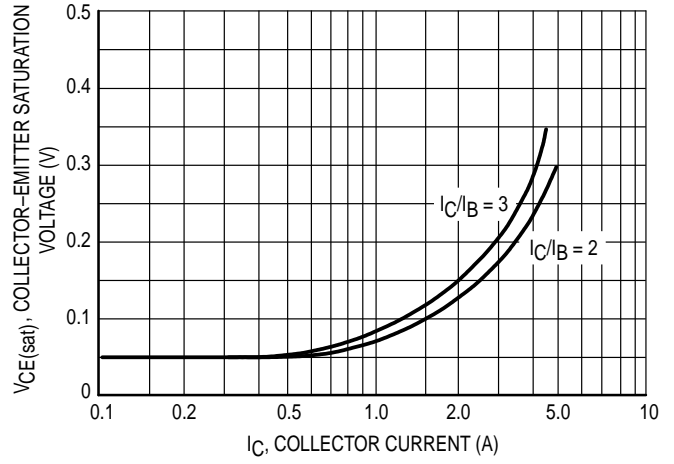

Figure 6. Collector-Emitter Saturation Voltage

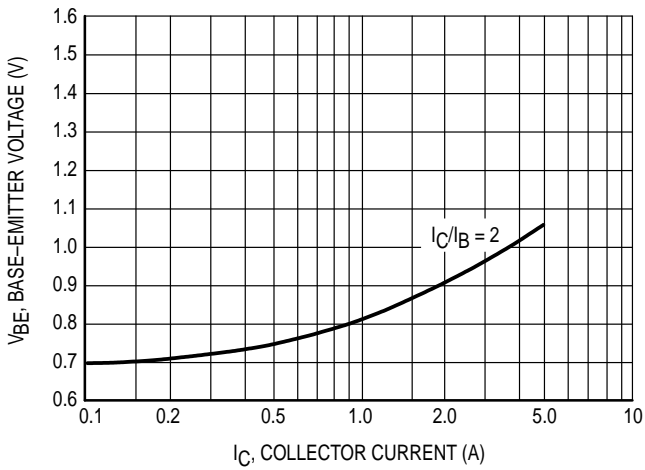

Figure 7. Base-Emitter Saturation Voltage

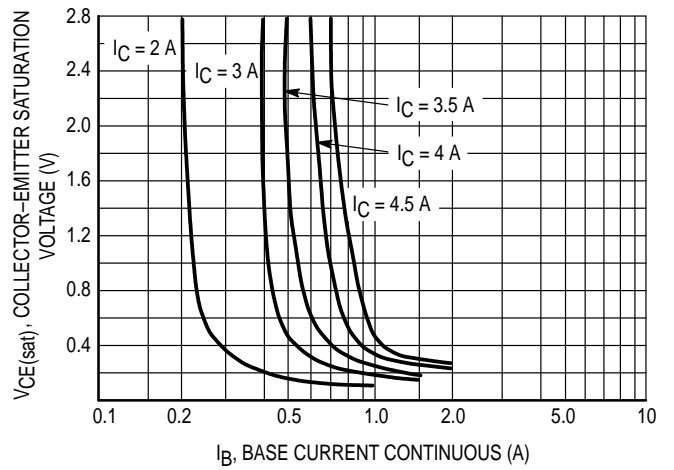

Figure 8. Collector Saturation Region

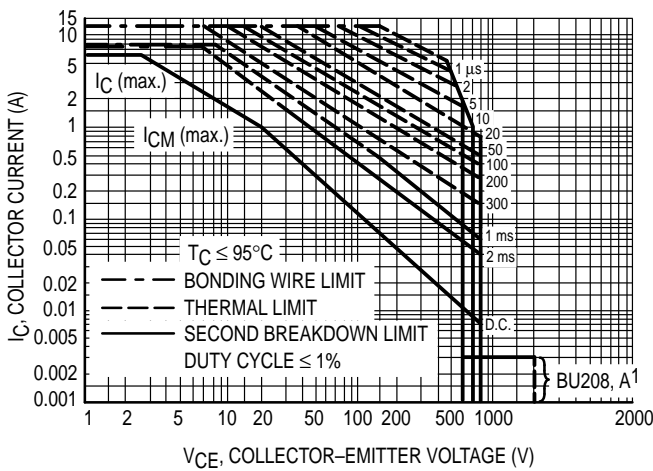
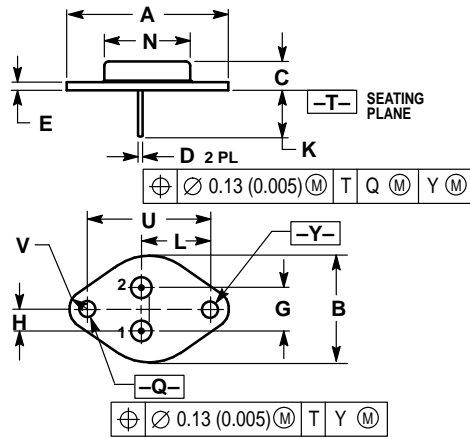

Figure 9. Maximum Forward Bias Safe Operating Area

¹Pulse width ≤ 20 μs. Duty cycle ≤ 0.25. R_{BE} ≤ 100 Ohms.

PACKAGE DIMENSIONS



- NOTES:
1. DIMENSIONING AND TOLERANCING PER ANSI Y14.5M, 1982.
 2. CONTROLLING DIMENSION: INCH.
 3. ALL RULES AND NOTES ASSOCIATED WITH REFERENCED TO-204AA OUTLINE SHALL APPLY.

DIM	INCHES		MILLIMETERS	
	MIN	MAX	MIN	MAX
A	1.550 REF		39.37 REF	
B	—	1.050	—	26.67
C	0.250	0.335	6.35	8.51
D	0.038	0.043	0.97	1.09
E	0.055	0.070	1.40	1.77
G	0.430 BSC		10.92 BSC	
H	0.215 BSC		5.46 BSC	
K	0.440	0.480	11.18	12.19
L	0.665 BSC		16.89 BSC	
N	—	0.830	—	21.08
Q	0.151	0.165	3.84	4.19
U	1.187 BSC		30.15 BSC	
V	0.131	0.188	3.33	4.77

- STYLE 1:
- PIN 1: BASE
 - EMITTER
- CASE: COLLECTOR

CASE 1-07
TO-204AA (TO-3)
ISSUE Z

Motorola reserves the right to make changes without further notice to any products herein. Motorola makes no warranty, representation or guarantee regarding the suitability of its products for any particular purpose, nor does Motorola assume any liability arising out of the application or use of any product or circuit, and specifically disclaims any and all liability, including without limitation consequential or incidental damages. "Typical" parameters can and do vary in different applications. All operating parameters, including "Typicals" must be validated for each customer application by customer's technical experts. Motorola does not convey any license under its patent rights nor the rights of others. Motorola products are not designed, intended, or authorized for use as components in systems intended for surgical implant into the body, or other applications intended to support or sustain life, or for any other application in which the failure of the Motorola product could create a situation where personal injury or death may occur. Should Buyer purchase or use Motorola products for any such unintended or unauthorized application, Buyer shall indemnify and hold Motorola and its officers, employees, subsidiaries, affiliates, and distributors harmless against all claims, costs, damages, and expenses, and reasonable attorney fees arising out of, directly or indirectly, any claim of personal injury or death associated with such unintended or unauthorized use, even if such claim alleges that Motorola was negligent regarding the design or manufacture of the part. Motorola and are registered trademarks of Motorola, Inc. Motorola, Inc. is an Equal Opportunity/Affirmative Action Employer.

How to reach us:
USA/EUROPE: Motorola Literature Distribution;
P.O. Box 20912; Phoenix, Arizona 85036. 1-800-441-2447

JAPAN: Nippon Motorola Ltd.; Tatsumi-SPD-JLDC, Toshikatsu Otsuki,
6F Seibu-Butsuryu-Center, 3-14-2 Tatsumi Koto-Ku, Tokyo 135, Japan. 03-3521-8315

MFAX: RMFAX0@email.sps.mot.com - TOUCHTONE (602) 244-6609
INTERNET: <http://Design-NET.com>

HONG KONG: Motorola Semiconductors H.K. Ltd.; 8B Tai Ping Industrial Park,
51 Ting Kok Road, Tai Po, N.T., Hong Kong. 852-26629298



This datasheet has been downloaded from:

www.DatasheetCatalog.com

Datasheets for electronic components.



LittleDiode supplies new, hard to find or obsolete electronic components and semiconductors all over the world.

With over two million different components listed you are sure to find the part you need.

Feel free to visit us today at our online store:

LittleDiode.com

Looking forward to providing you with the best possible service.