

2N2222A

Features

- Meets MIL 19500 /255
- Collector - Base Voltage 75 V
- Collector - Current 800 mA
- High Speed, Medium Current Bipolar Transistor

SWITCHING
 TRANSISTOR
 JAN, JANTX, JANTXV

SMALL SIGNAL
 BIPOLAR
 NPN SILICON

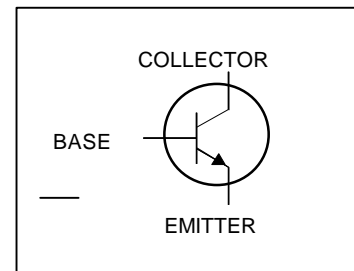
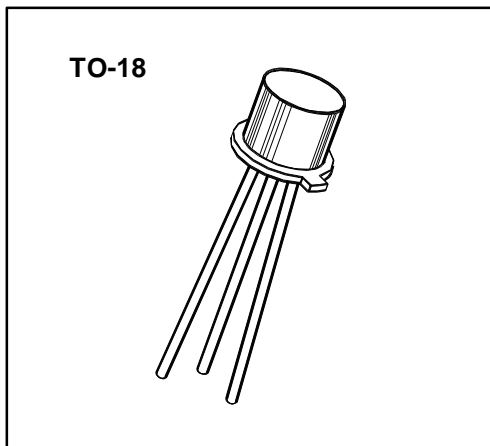

Maximum Ratings

RATING	SYMBOL	VALUE	UNIT
Collector - Emitter Voltage	V_{CEO}	50	Vdc
Collector - Base Voltage	V_{CBO}	75	Vdc
Emitter - Base Voltage	V_{EBO}	6	Vdc
Collector Current -- Continuous	I_C	800	mAdc
Total Device Dissipation @ $T_A = 25\text{ }^\circ\text{C}$	P_D	500	mW
Derate above 25 $^\circ\text{C}$		2.85	mW/ $^\circ\text{C}$
Total Device Dissipation @ $T_C = 25\text{ }^\circ\text{C}$	P_D	1.8	WATTS
Derate above 25 $^\circ\text{C}$		10.3	mW/ $^\circ\text{C}$
Operating Junction&Storage Temperature Range	T_J, T_{stg}	- 65 to + 200	$^\circ\text{C}$

Thermal Characteristics

CHARACTERISTIC	SYMBOL	MAX	UNIT
Thermal Resistance, Junction to Ambient	$R_{\theta JA}$	350	$^\circ\text{C/W}$

Electrical Characteristics ($T_A = 25^\circ\text{C}$ unless otherwise noted)

OFF CHARACTERISTIC	SYMBOL	MIN	MAX	UNIT
Collector - Emitter Breakdown Voltage (1) ($I_C = 10 \text{ mA dc}$, $I_B = 0$)	$V(BR)_{CEO}$	50		Vdc
Collector - Base Breakdown Voltage (1) ($I_C = 10 \text{ mAdc}$, $I_E = 0$)	$V(BR)_{CBO}$	75		Vdc
Emitter - Base Breakdown Voltage (1) ($I_E = 10 \text{ mAdc}$, $I_C = 0$)	$V(BR)_{EBO}$	6		Vdc
Collector - Emitter Cutoff Current ($V_{CE} = 50 \text{ Vdc}$, $V_{BE(off)} = 0 \text{ V}$)	I_{CES}		50	nAdc
Collector - Base Cutoff Current ($V_{CB} = 60 \text{ Vdc}$, $I_E = 0$) ($V_{CB} = 60 \text{ Vdc}$, $I_E = 0$, $T_A = 150^\circ\text{C}$)	I_{CBO}		10 10	nAdc mAdc
Emitter - Base Cutoff Current ($V_{EB} = 4 \text{ Vdc}$)	I_{EBO}		10	nAdc

ON CHARACTERISTIC	SYMBOL	MIN	MAX	UNIT
DC Current Gain ($I_C = 100 \text{ mA dc}$, $V_{CE} = 10 \text{ Vdc}$) ($I_C = 1 \text{ mA dc}$, $V_{CE} = 10 \text{ Vdc}$) ($I_C = 10 \text{ mA dc}$, $V_{CE} = 10 \text{ Vdc}$) ($I_C = 150 \text{ mA dc}$, $V_{CE} = 10 \text{ Vdc}$) (1) ($I_C = 500 \text{ mA dc}$, $V_{CE} = 10 \text{ Vdc}$) (1) ($I_C = 10 \text{ mA dc}$, $V_{CE} = 10 \text{ Vdc}$, $T_J = -55^\circ\text{C}$)	h_{FE}	50 75 100 100 30 35	325 300	
Collector - Emitter Saturation Voltage ($I_C = 150 \text{ mAdc}$, $I_B = 15 \text{ mAdc}$) (1) ($I_C = 500 \text{ mAdc}$, $I_B = 50 \text{ mAdc}$) (1)	$V_{CE(sat)}$		0.3 1.0	Vdc Vdc
Base - Emitter Saturation Voltage ($I_C = 150 \text{ mAdc}$, $I_B = 15 \text{ mAdc}$) (1) ($I_C = 500 \text{ mAdc}$, $I_B = 50 \text{ mAdc}$) (1)	$V_{BE(sat)}$	0.6	1.2 2.0	Vdc Vdc

1. Pulse Test: Pulse Width $\leq 300 \mu\text{s}$, Duty Cycle $\leq 2.0\%$

2N2222A

Electrical Characteristics ($T_A = 25^\circ\text{C}$ unless otherwise noted)

SMALL - SIGNAL CHARACTERISTICS	SYMBOL	MIN	MAX	UNIT
Output Capacitance ($V_{CB} = 10\text{ Vdc}$, $I_E = 0$, 100kHz &f &1 MHz)	C_{obo}		8	pF
Input Capacitance ($V_{EB} = 0.5\text{ Vdc}$, $I_C = 0$, 100kHz &f &1 MHz)	C_{ibo}		25	pF

SWITCHING CHARACTERISTICS	SYMBOL	MIN	MAX	UNIT
Turn - On Time ($V_{CC} = 30\text{ Vdc}$, $I_C = 150\text{ mAdc}$, $I_{B1} = 15\text{ mAdc}$) (See FIGURE 1)	t_{on}		35	ns
Turn - Off Time ($V_{CC} = 30\text{ Vdc}$, $I_C = 150\text{ mAdc}$, $I_{B1} = -I_{B2} = 15\text{ mAdc}$) (See FIGURE 2)	t_{off}		300	ns

Small - Signal AC Characteristics ($T_A = 25^\circ\text{C}$)

LOW FREQUENCY	SYMBOL	MIN	MAX	UNIT
Common - Emitter Forward Current Transfer Ratio ($I_C = 1\text{ mA}$, $V_{CE} = 10\text{ V}$, $f = 1\text{ kHz}$)	h_{fe}	50		
HIGH FREQUENCY				
Common - Emitter Forward Current Transfer Ratio ($I_C = 20\text{ mA}$, $V_{CE} = 20\text{ V}$, $f = 100\text{ MHz}$)	$ h_{fe} $	2.5		

Spice Model (based upon typical device characteristics) *1

Q2N2222A NPN (IS = 19.34n XT = 3.0 EG = 1.11 VAF=250.3 BF = 163.8 ISE =174.3f
 + NE = 1.647 IKF = 3.0 NK = 0.3052 XTB = 1.5 BR = 11.49 ISC = 19.9f
 + NC = 1.88 IKR = 10.75 RC = 0.3567 CJC = 11.02p VJC = 0.3869 MJC = 0.3292
 + FC = 0.5 CJE = 29.31p VJE = 0.9036 MJE = 0.4101 TR = 38.32n TF =361.8p
 + ITF = 5.282 XTF = 249.9 VTF=10)

*1. Microsemi Corp. claims no responsibility for misapplication of Spice Model information. Spice modeling should be used as a precursor guide to in-circuit performance. Actual performance is the responsibility of the user/designer.

2N2222A

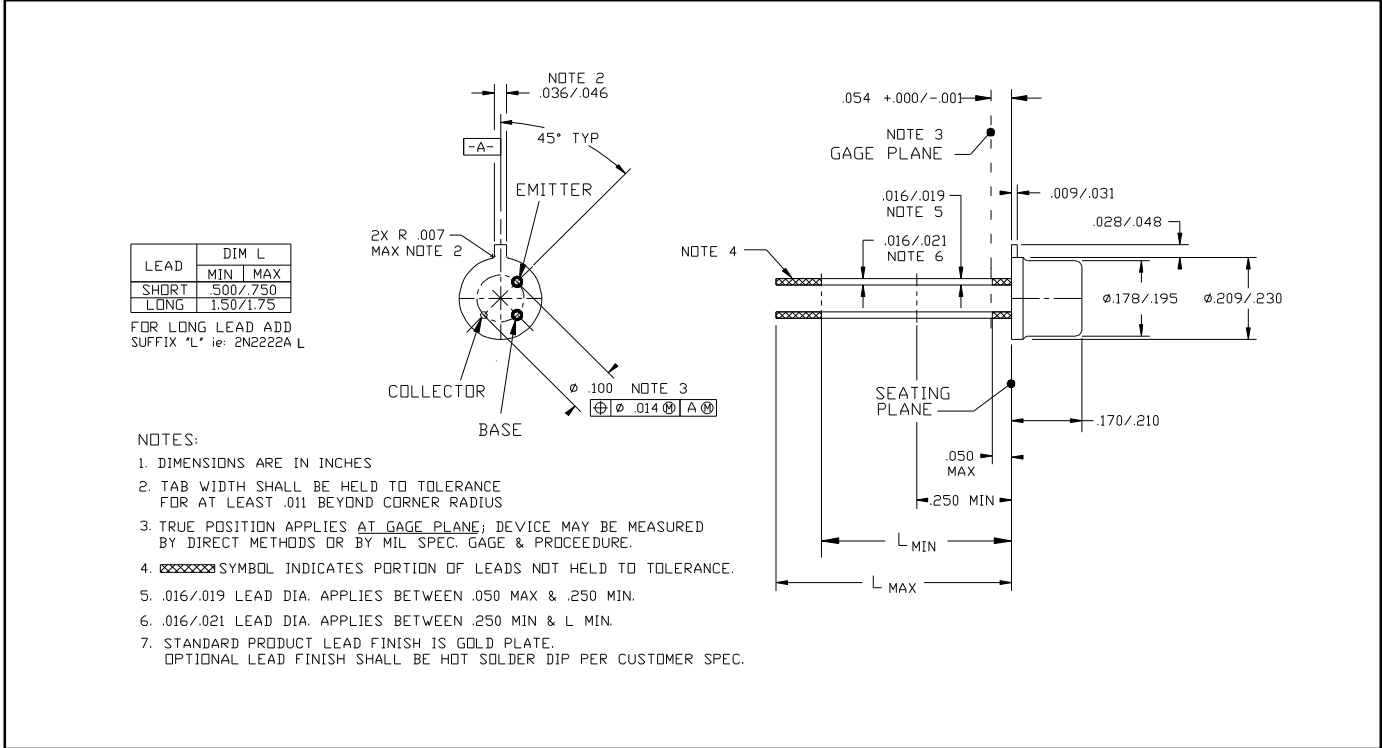

TO 18 CASE OUTLINE

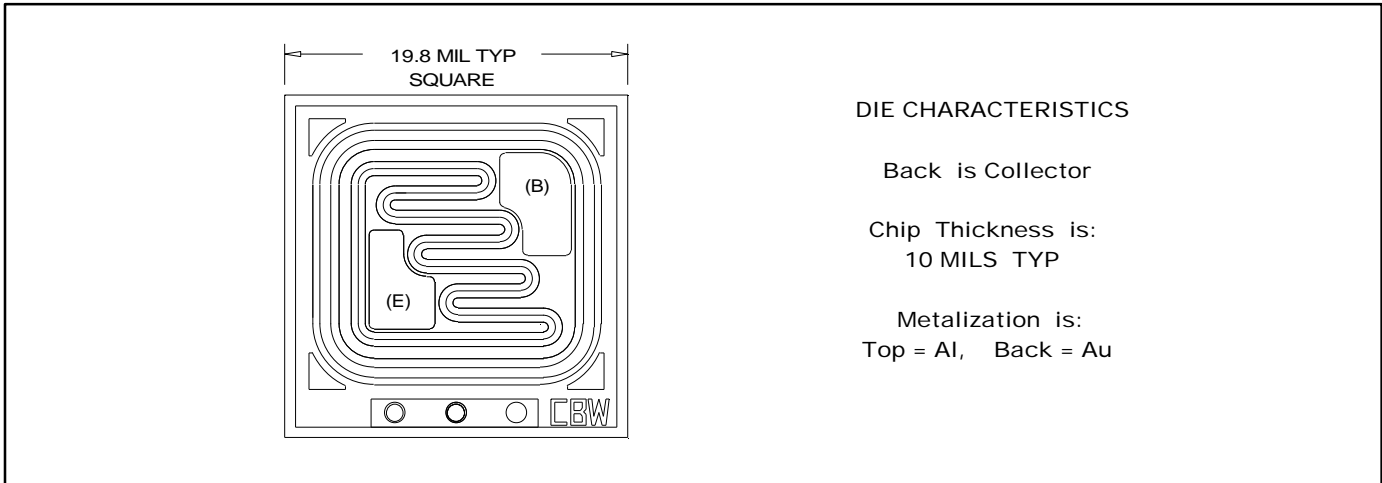

DIE OUTLINE

2N2222A

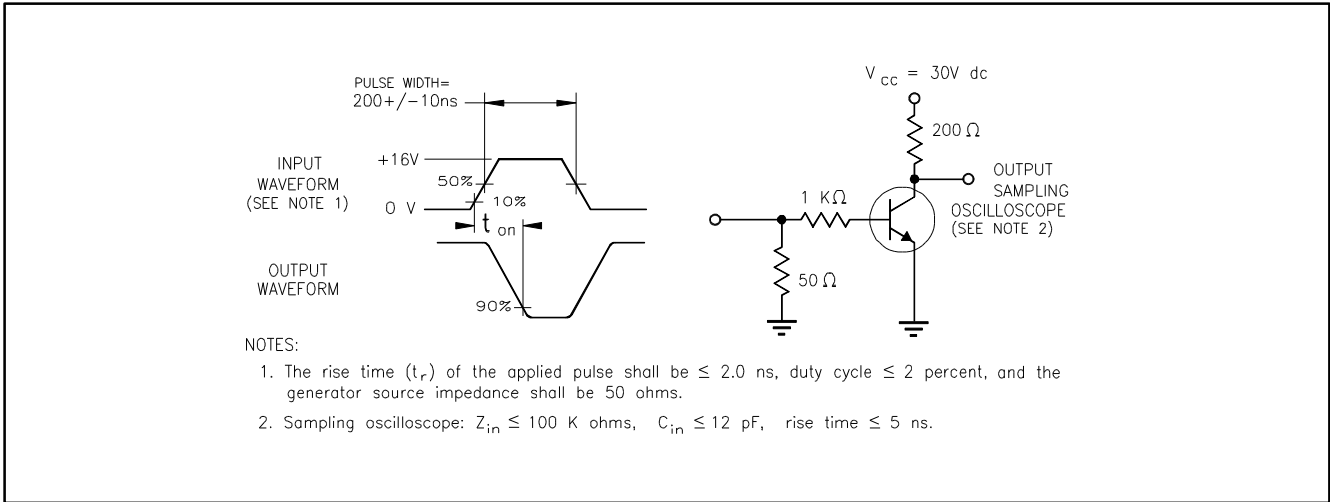

FIGURE 1 Saturated Turn-on Time Test Circuit

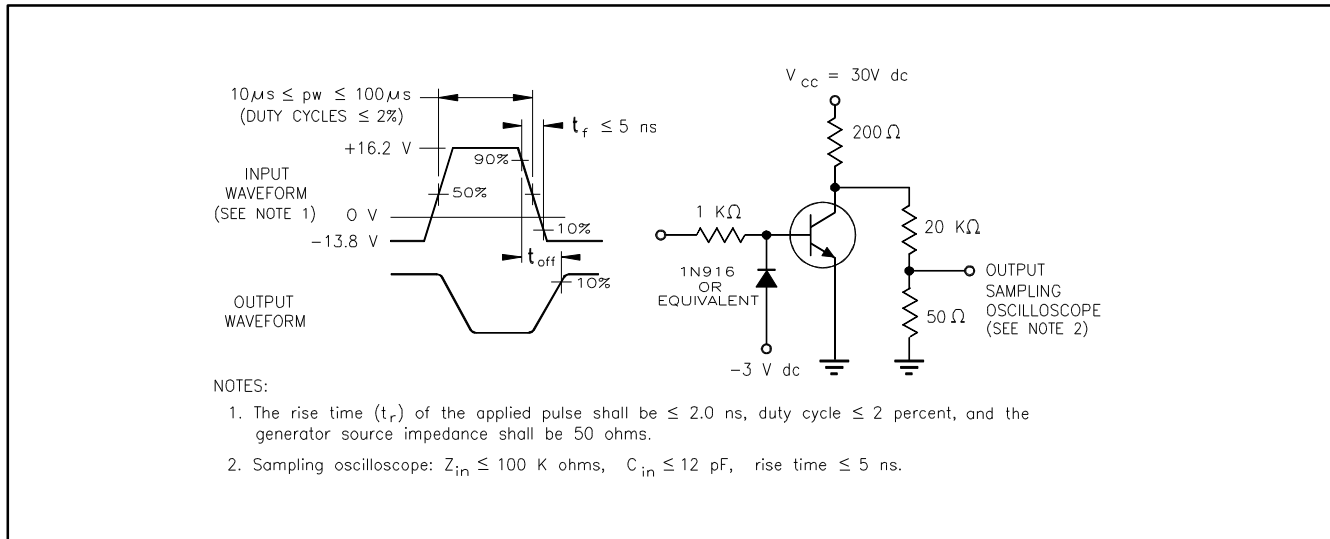

FIGURE 2 Saturated Turn-off Time Test Circuit

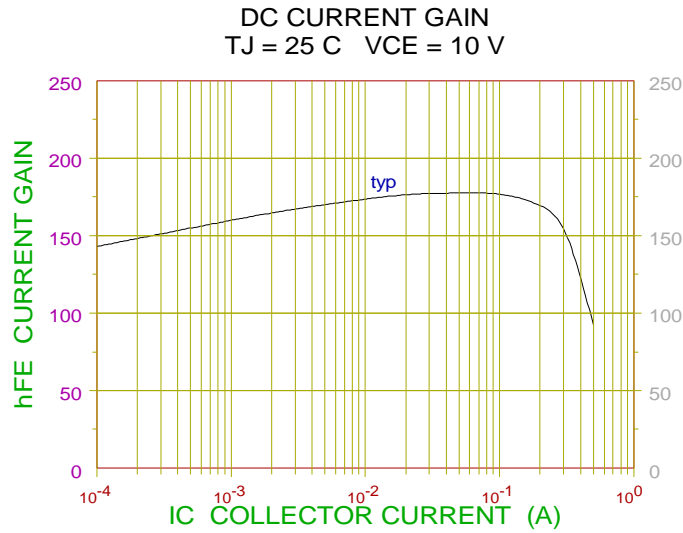

FIGURE 3

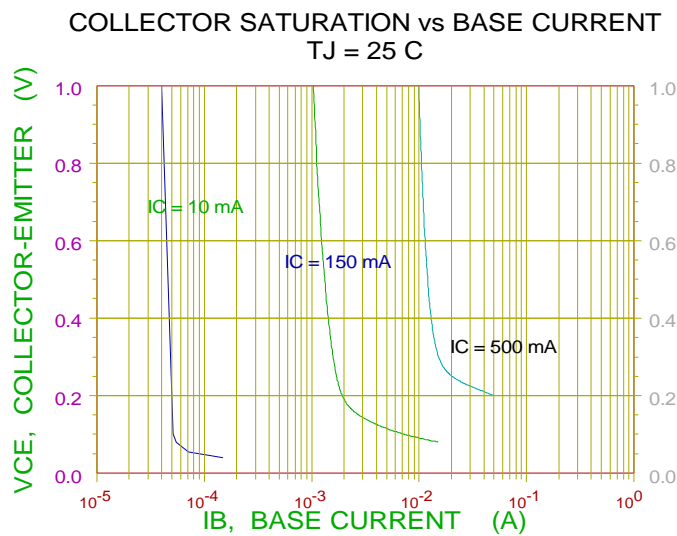

FIGURE 4

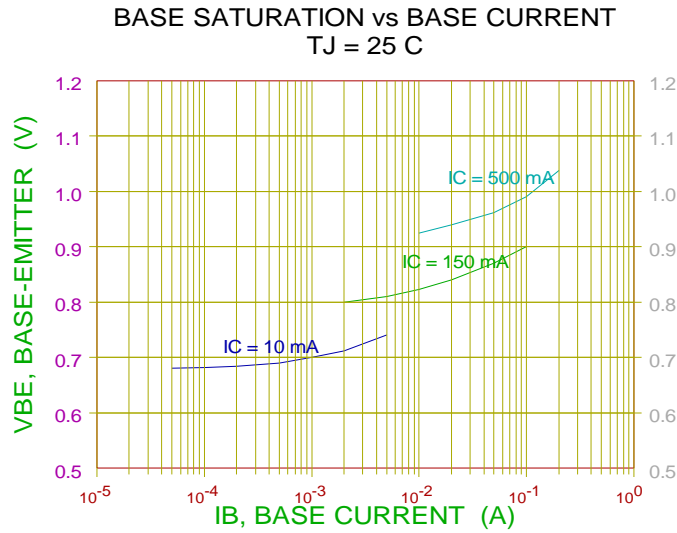

FIGURE 5

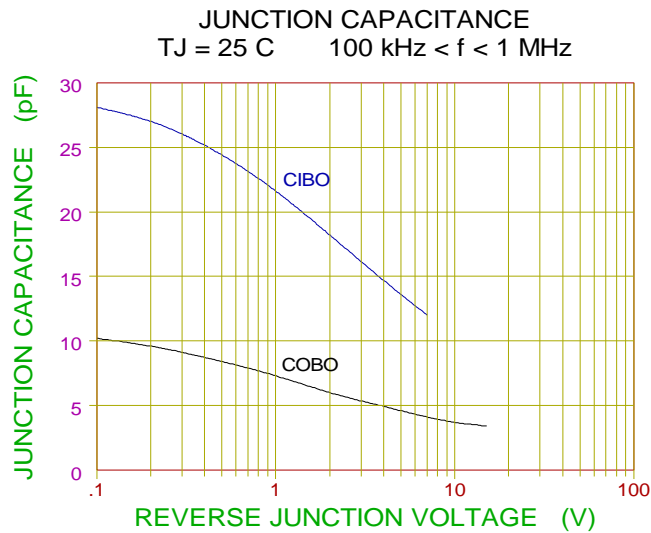

FIGURE 6

SMALL SIGNAL CURENT GAIN vs COLLECTOR CURRENT
TJ = 25 C VCE = 10 V f = 1kHz

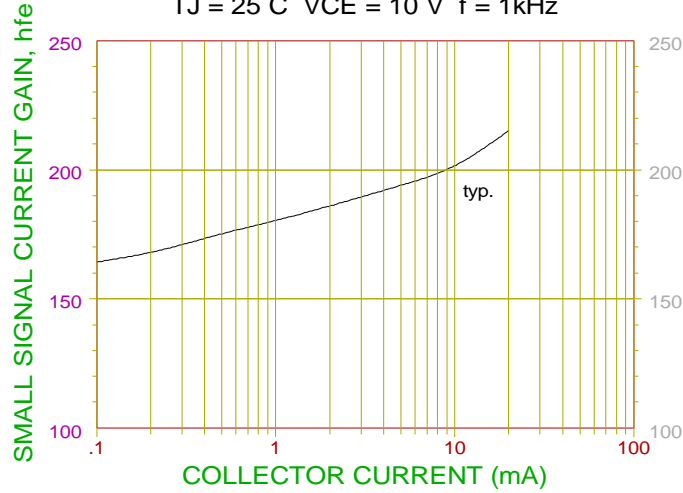

FIGURE 7

HIGH FREQUENCY GAIN
TJ = 25 C VCE = 20 V f = 100 MHz

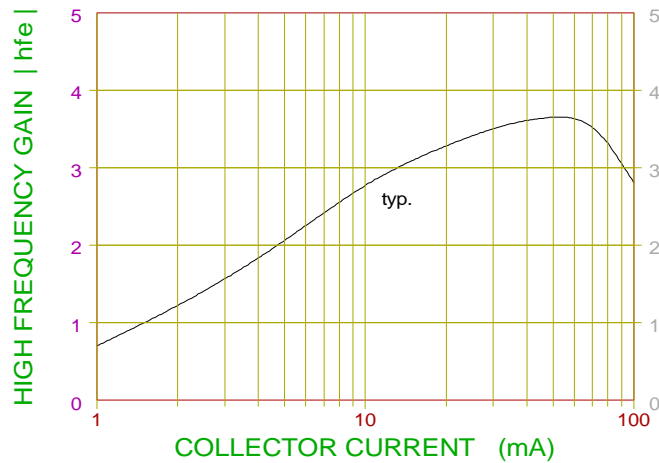

FIGURE 8

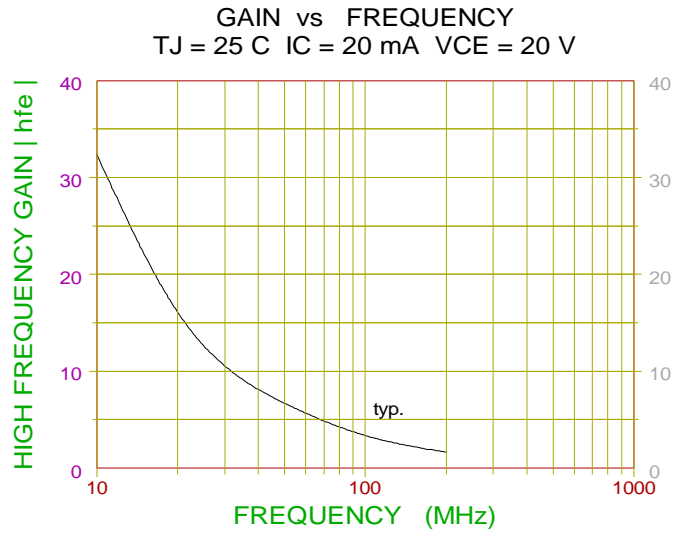

FIGURE 9



LittleDiode supplies new, hard to find or obsolete electronic components and semiconductors all over the world.

With over two million different components listed you are sure to find the part you need.

Feel free to visit us today at our online store:

LittleDiode.com

Looking forward to providing you with the best possible service.