

**2N2484**

## Features

- Meets MIL 19500 /376
- Collector - Base Voltage 60 V
- Collector - Current 50 mA
- High Speed, Low Power Bipolar Transistor

**SWITCHING  
 TRANSISTOR  
 JAN, JANTX, JANTXV**

**SMALL SIGNAL  
 BIPOLAR  
 NPN SILICON**

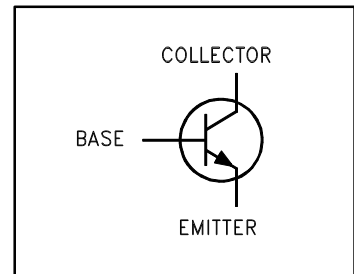
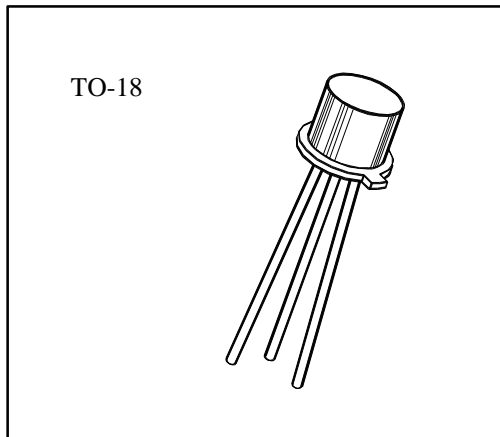

## Maximum Ratings

RATING	SYMBOL	VALUE	UNIT
Collector - Emitter Voltage	$V_{CEO}$	60	Vdc
Collector - Base Voltage	$V_{CB0}$	60	Vdc
Emitter - Base Voltage	$V_{EBO}$	6	Vdc
Collector Current - Continuous	$I_C$	50	mAdc
Total Device Dissipation @ $T_A = 25\text{ }^\circ\text{C}$	$P_D$	360	mW
Derate above 25 $^\circ\text{C}$		2.06	mW/ $^\circ\text{C}$
Total Device Dissipation @ $T_C = 25\text{ }^\circ\text{C}$	$P_D$	1.2	WATTS
Derate above 25 $^\circ\text{C}$		6.85	mW/ $^\circ\text{C}$
Operating Junction&Storage Temperature Range	$T_J, T_{stg}$	-65 to +200	$^\circ\text{C}$

## Thermal Characteristics

CHARACTERISTIC	SYMBOL	MAX	UNIT
Thermal Resistance, Junction to Ambient	$R_{\theta JA}$	485	$^\circ\text{C/W}$

Electrical Characteristics ( $T_A = 25^\circ\text{C}$  unless otherwise noted)

OFF CHARACTERISTIC	SYMBOL	MIN	MAX	UNIT
Collector - Emitter Breakdown Voltage (1)	$V(BR)_{CEO}$			
( $I_C = 10 \text{ mAdc}$ , $I_B = 0$ )		60		Vdc
Collector - Base Breakdown Voltage	$V(BR)_{CBO}$			
( $I_C = 10 \text{ mAdc}$ , $I_E = 0$ )		60		Vdc
Emitter - Base Breakdown Voltage	$V(BR)_{EBO}$			
( $I_E = 10 \text{ mAdc}$ , $I_C = 0$ )		6		Vdc
Collector - Base Cutoff Current	$I_{CBO}$			
( $V_{CB} = 45 \text{ Vdc}$ , $I_E = 0$ )			5	nAdc
( $V_{CB} = 45 \text{ Vdc}$ , $I_E = 0$ , $T_A = 150^\circ\text{C}$ )			10	mAdc
Collector - Emitter Cutoff Current	$I_{CEO}$			
( $V_{CE} = 5 \text{ Vdc}$ , $I_B = 0$ )			2	nAdc
Collector - Emitter Cutoff Current	$I_{CES}$			
( $V_{CE} = 45 \text{ Vdc}$ , $V_{BE} = 0$ )			5	nAdc
Emitter - Base Cutoff Current	$I_{EBO}$			
( $V_{EB} = 5 \text{ Vdc}$ )			2	nAdc

ON CHARACTERISTIC	SYMBOL	MIN	MAX	UNIT
DC Current Gain	$h_{FE}$			
( $I_C = 1 \text{ mAdc}$ , $V_{CE} = 5 \text{ Vdc}$ )		45		
( $I_C = 10 \text{ mAdc}$ , $V_{CE} = 5 \text{ Vdc}$ )		200	500	
( $I_C = 100 \text{ mAdc}$ , $V_{CE} = 5 \text{ Vdc}$ )		225	675	
( $I_C = 500 \text{ mAdc}$ , $V_{CE} = 5 \text{ Vdc}$ )		250	800	
( $I_C = 1 \text{ mAdc}$ , $V_{CE} = 5 \text{ Vdc}$ )		250	800	
( $I_C = 10 \text{ mAdc}$ , $V_{CE} = 5 \text{ Vdc}$ )		225	800	
( $I_C = 10 \text{ mAdc}$ , $V_{CE} = 5 \text{ Vdc}$ , $T_J = -55^\circ\text{C}$ )		35		
Collector- Emitter Saturation Voltage	$V_{CE(sat)}$			
( $I_C = 1 \text{ mAdc}$ , $I_B = 100 \text{ mAdc}$ )			0.3	Vdc
Base - Emitter Non-Saturated Voltage	$V_{BE(on)}$			
( $I_C = 100 \text{ mAdc}$ , $V_{CE} = 5 \text{ Vdc}$ )		0.5	0.7	Vdc

1. Pulse Test: Pulse Width  $\leq 300 \mu\text{s}$ , Duty Cycle  $\leq 2\%$

Electrical Characteristics ( $T_A = 25^\circ\text{C}$  unless otherwise noted)

SMALL - SIGNAL CHARACTERISTICS	SYMBOL	MIN	MAX	UNIT
Output Capacitance ( $V_{CB} = 5 \text{ Vdc}$ , $I_E = 0$ , 100kHz $\times$ f $\leq$ 1 MHz)	$C_{obo}$		5	pF
Input Capacitance ( $V_{EB} = 0.5 \text{ Vdc}$ , $I_C = 0$ , 100kHz $\times$ f $\leq$ 1 MHz)	$C_{ibo}$		6	pF

Small - Signal AC Characteristics ( $T_A = 25^\circ\text{C}$ )

LOW FREQUENCY	SYMBOL	MIN	MAX	UNIT
Common - Emitter Forward Current Transfer Ratio ( $I_C = 1 \text{ mA}$ , $V_{CE} = 5 \text{ V}$ , $f = 1 \text{ kHz}$ )	$h_{fe}$	250	900	
Common - Emitter Short Circuit Input Impedance ( $I_C = 1 \text{ mA}$ , $V_{CE} = 5 \text{ V}$ , $f = 1 \text{ kHz}$ )	$h_{ie}$	3.5	24	k $\Omega$
Common - Emitter Open Circuit Output Admittance ( $I_C = 1 \text{ mA}$ , $V_{CE} = 5 \text{ V}$ , $f = 1 \text{ kHz}$ )	$h_{oe}$		40	mhos
Common-Emitter Open Circuit Reverse Voltage Transfer Ratio ( $I_C = 1 \text{ mA}$ , $V_{CE} = 5 \text{ V}$ , $f = 1 \text{ kHz}$ )	$h_{re}$		$8.0 \times 10^{-4}$	
<b>HIGH FREQUENCY AND NOISE</b>				
<b>Magnitude of Common Emitter</b>				
Short Circuit Forward Current Transfer Ratio ( $I_C = 50 \text{ mA}$ , $V_{CE} = 5 \text{ V}$ , $f = 5 \text{ MHz}$ )	$ \hat{h}_{fe} $	3.0		
( $I_C = 500 \text{ mA}$ , $V_{CE} = 5 \text{ V}$ , $f = 30 \text{ MHz}$ )		2.0	7.0	
Noise Figure ( $I_C = 10 \text{ mA}$ , $V_{CE} = 5 \text{ Vdc}$ , $R_G = 10 \text{ k}\Omega$ , $f = 100 \text{ Hz}$ )	$F_1$		7.5	dB
Noise Figure ( $I_C = 10 \text{ mA}$ , $V_{CE} = 5 \text{ Vdc}$ , $R_G = 10 \text{ k}\Omega$ , $f = 1 \text{ kHz}$ )	$F_2$		3.0	dB
Noise Figure ( $I_C = 10 \text{ mA}$ , $V_{CE} = 5 \text{ Vdc}$ , $R_G = 10 \text{ k}\Omega$ , $f = 10 \text{ kHz}$ )	$F_3$		2.0	dB
Wide Band Noise Figure ( $I_C = 10 \text{ mA}$ , $V_{CE} = 5 \text{ Vdc}$ , $R_G = 10 \text{ k}\Omega$ , $f = 10 \text{ Hz to } 15.7 \text{ kHz}$ )	$F_4$		3.0	dB

Spice Model (based upon typical device characteristics) \*1

Q2N2484 NPN (IS = 66.4p XTI = 2.0m EG = 1.11 VAF = 73.1 BF = 660.0 ISE = 48.8n  
 + NE = 46.13 IKF = 8.98m NK = 0.123 XTB = 1.5 BR = 1.0 ISC = 66.4p  
 + NC = 2.51 IKR = 1.23 RC = 0.738 CJC = 4.74p VJC = 0.933 MJC = 0.35  
 + FC = 0.5 CJE = 6.0p VJE = 0.6 MJE = 0.34 TR = 25.96n TF = 1.918n  
 + ITF = 1.0 XTF = 0 VTF = 10.0)

\*1. Microsemi Corp. claims no responsibility for misapplication of Spice Model information. Spice modeling should be used as a precursor guide to in-circuit performance. Actual performance is the responsibility of the user / designer.

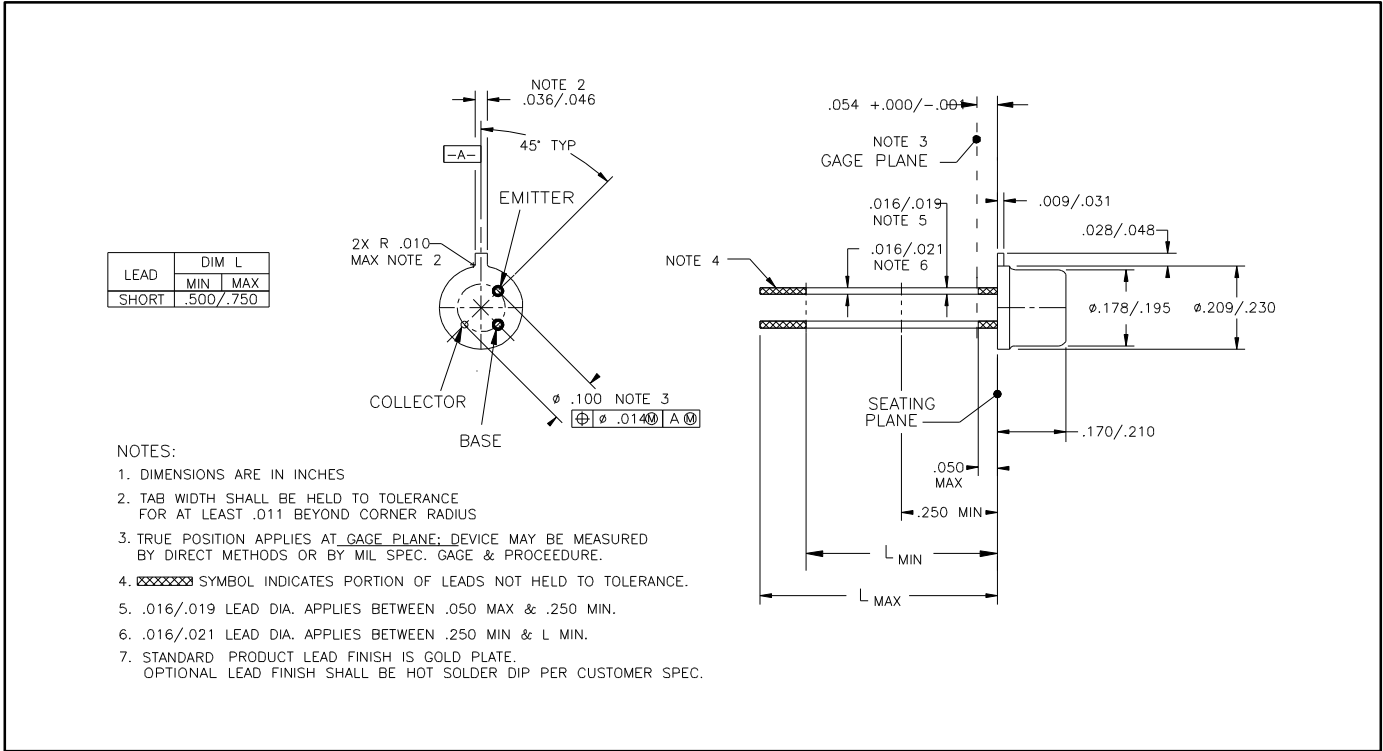

**TO 18 CASE OUTLINE**

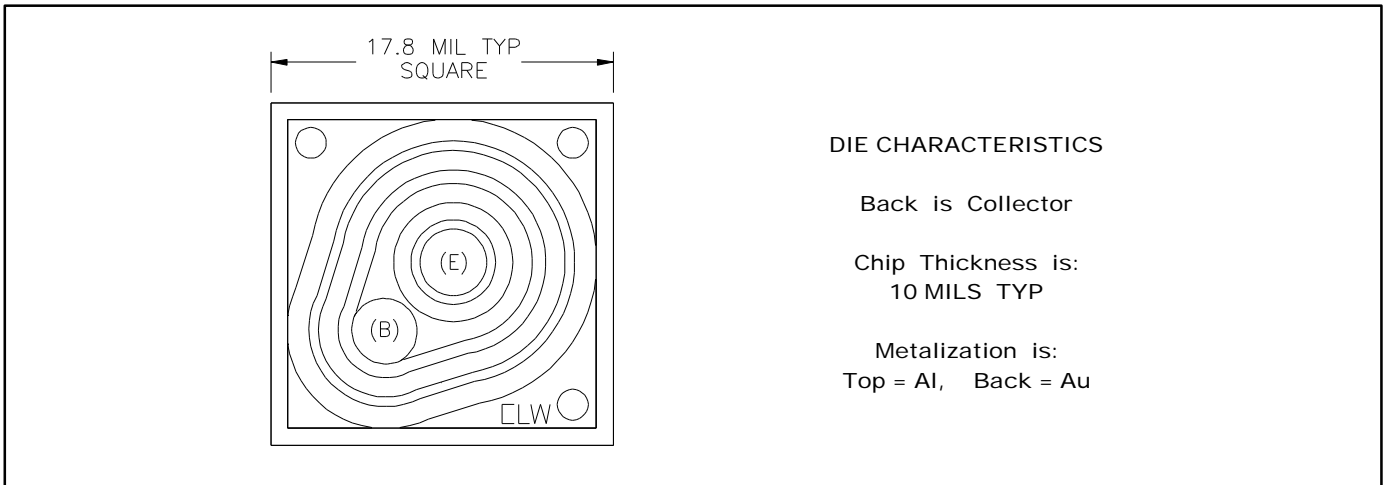

**DIE OUTLINE**

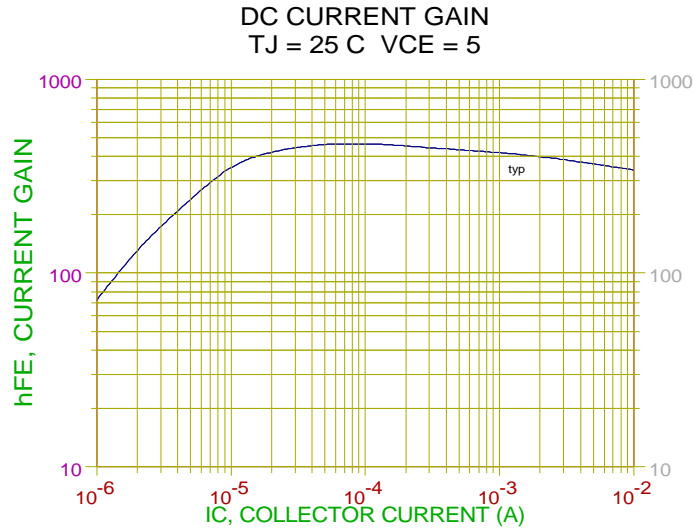

FIGURE 1

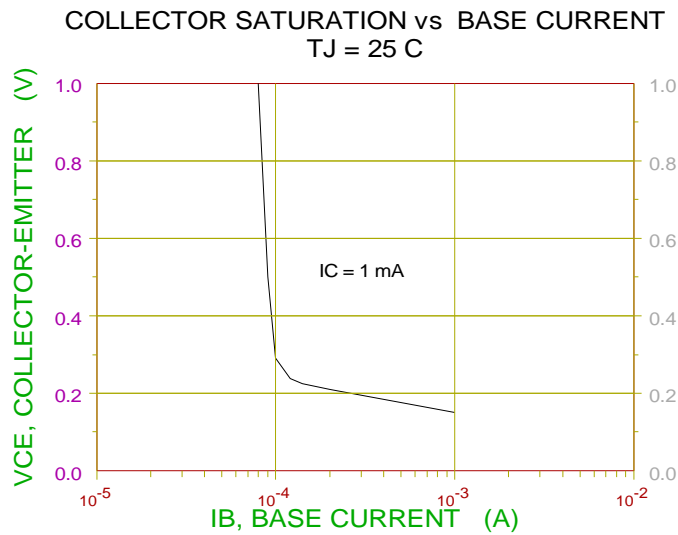
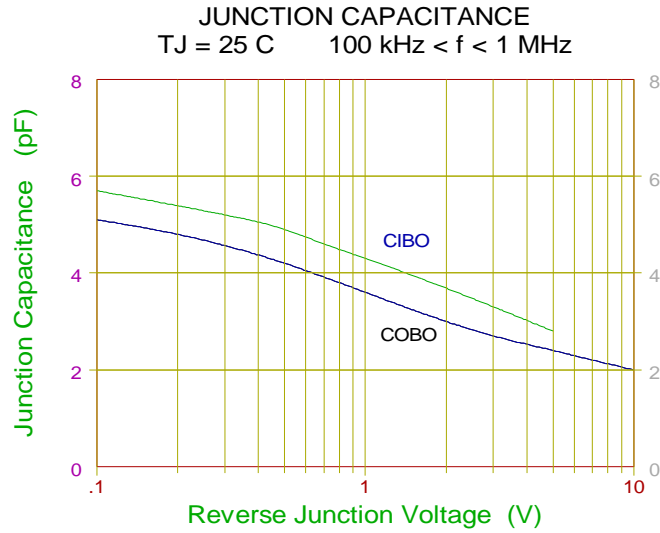
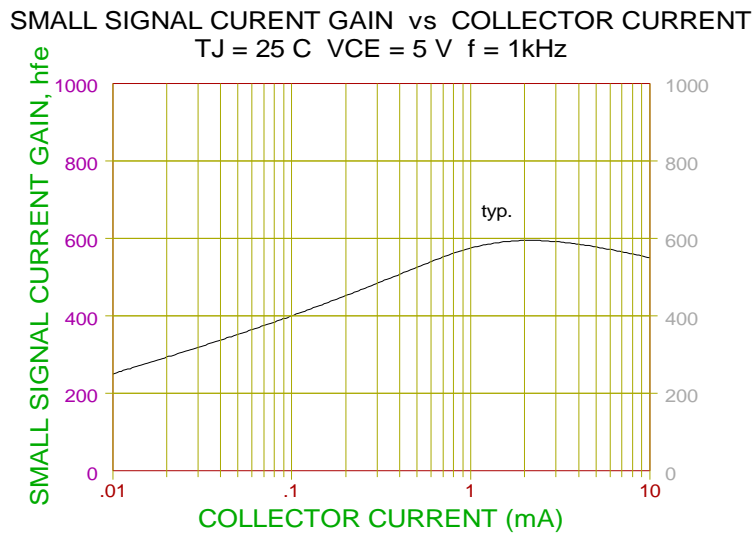

FIGURE 2



**FIGURE 3**



**FIGURE 4**

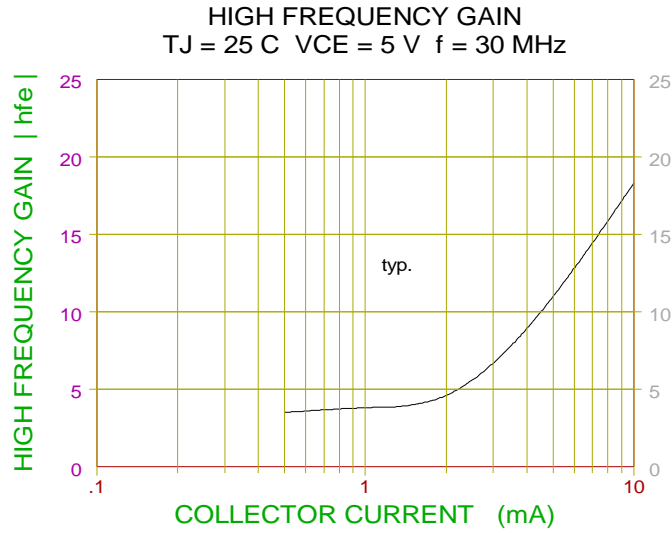

FIGURE 5

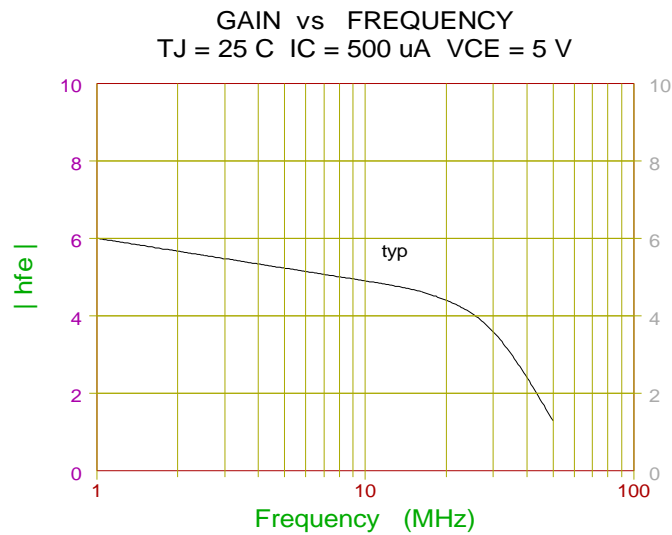
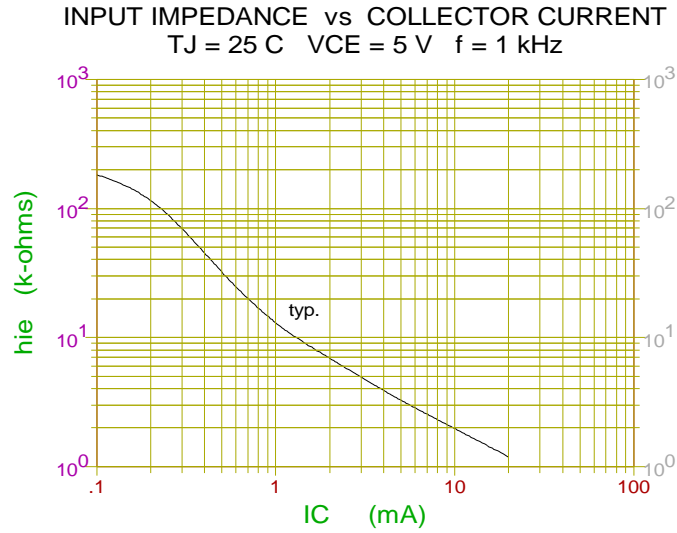
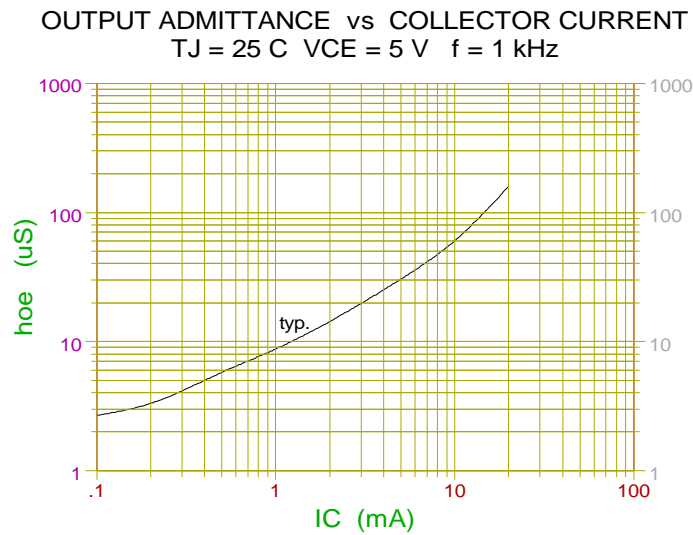

FIGURE 6



**FIGURE 7**



**FIGURE 8**

VOLTAGE FEEDBACK RATIO vs COLLECTOR CURRENT  
 T<sub>J</sub> = 25 C V<sub>CE</sub> = 5 V f = 1kHz

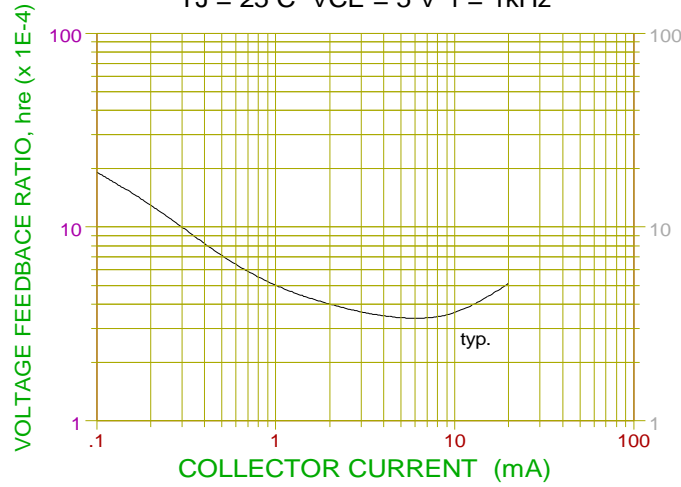

FIGURE 9

NOISE FIGURE (db) VS COLLECTOR CURRENT  
 T<sub>J</sub> = 25 C V<sub>CE</sub> = 5 V R<sub>G</sub> = 10 k f = 1 kHz

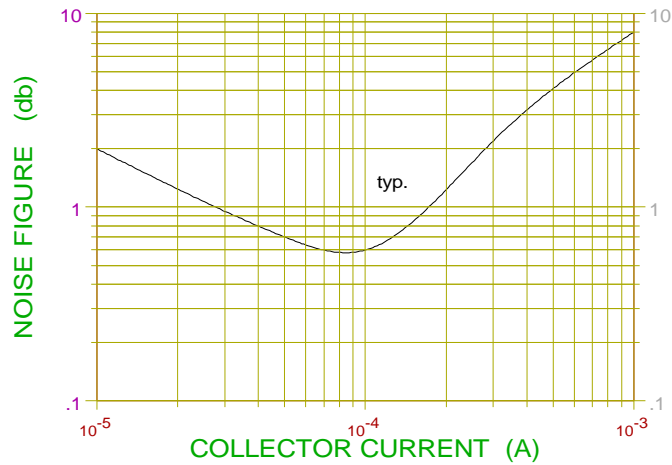
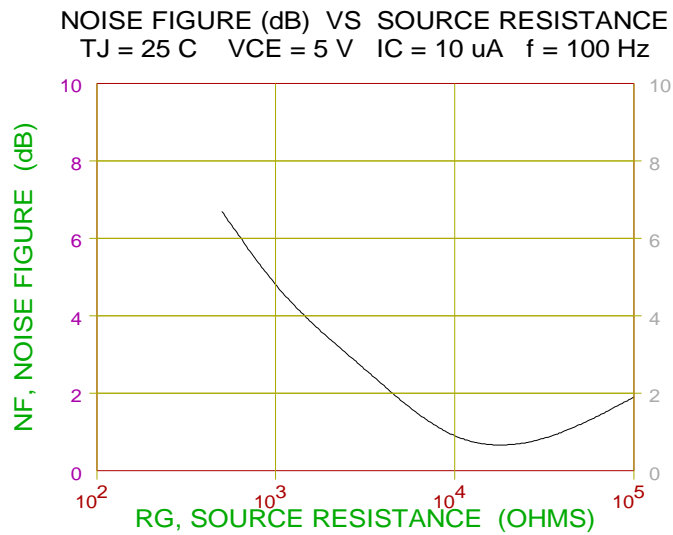

FIGURE 10



**FIGURE 11**



LittleDiode supplies new, hard to find or obsolete electronic components and semiconductors all over the world.

With over two million different components listed you are sure to find the part you need.

Feel free to visit us today at our online store:

[LittleDiode.com](http://LittleDiode.com)

Looking forward to providing you with the best possible service.