

Horizontal Deflection Transistor Series for TV

Overview

Based on accumulated manufacturing technology, these horizontal deflection transistors for TVs offer high performance and compact design. They can also withstand high voltage and maintain low loss. They also have a broad area of safe-operation, despite an absolutely minimal chip area which allows very compact package configuration. These advanced features contribute to higher performing, more reliable home-use TVs that cost less.

Features

- Withstands ultrahigh voltage : 1500V/1600V/1700V/1800V/2000V
- Low loss: $V_{CE(sat)} < 3V$
- Broad area of safe-operation.

Specifications

Parameter Part No.	Package		Electric Characteristics			Recommended condition	
	Now	Compact packaging	I _c (A)	V _{CBO} (V)	Damper diode	f _H (kHz)	Screen size (inch)
2SC5657	TOP-3E	Possible	4	1500	Built-in	15.75	to 14
2SC5622/2SC5572	TOP-3E/3D	Possible	6				to 25
2SC5518/2SC5523	TOP-3E/3D	Possible	7				to 29
2SC5514/2SC5521	TOP-3E/3D	Possible	13		Not built-in	32	to 32
2SC5517/2SC5522	TOP-3E/3D	Possible	6	1600/1700	Built-in	15.75	to 29
2SC5519/2SC5524	TOP-3E/3D	Possible	8				to 36
2SC5516/2SC5584	TOP-3E/3L	—	20	1500	Not built-in	32	to 36
2SC5546	TOP-3E	—	18	1700			
2SC5553/2SC5597	TOP-3E/3L	—	22			1700	64
2SC5591/2SC5591A	TOP-3E	—	20	1700/1800			
2SC5686	TOP-3E	—	20	2000			

Applications

- TVs ●Wide-screen TVs ●Digital TVs

! The products and specifications are subject to change without any notice. Please ask for the latest product standards to guarantee the satisfaction of your product requirements.

Semiconductor Company, Matsushita Electronics Corporation

2SC5514

■ Absolute Maximum Ratings

Parameter	Symbol	Rating	Unit
Collector to base voltage	VCBO	1500	V
Collector to emitter voltage	VCES	1500	V
Collector to emitter voltage	VCEO	600	V
Emitter to base voltage	VEBO	7	V
Peak collector current	ICP	23*3	A
Collector current	IC	13	A
Base current	IB	6	A
Collector power dissipation	PC	50*1 3.0*2	W
Junction temperature	Tj	150	°C
Storage temperature	Tstg	-55 to +150	°C

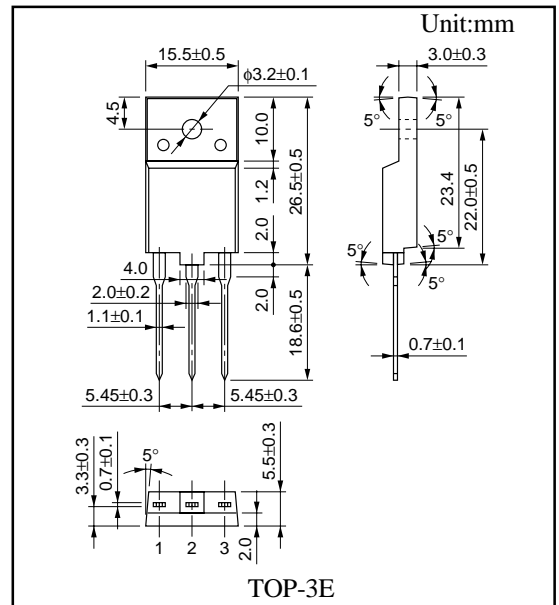

*1)TC=25°C *2)Ta=25°C (Without heat sink)

*3)Non-repetitive peak collector current.

■ Electrical Characteristics(TC=25°C)

Parameter	Symbol	Conditions	min	typ	max	Unit
Collector cutoff current	ICBO	V _{CB} =1000V, I _E =0	-	-	50	μA
	ICBO	V _{CB} =1500V, I _E =0	-	-	1	mA
Emitter cutoff current	IEBO	V _{EB} =7V, I _C =0	-	-	50	μA
Forward current transfer ratio	f _{FE}	V _{CE} =5V, I _C =6.5A	5	-	9	
Collector to emitter saturation voltage	V _{CE(sat)}	I _C =6.5A, I _B =1.63A	-	-	3	V
Base to emitter saturation voltage	V _{BE(sat)}	I _C =6.5A, I _B =1.63A	-	-	1.5	V
Transition frequency	f _T	V _{CE} =10V, I _C =0.1A, f=0.5MHz	-	3	-	MHz
Fall time	T _f	I _C =6.5A, I _{B1} =1.63A, I _{B2} =-3.25A	-	-	0.2	μs
Storage time	T _{stg}	I _C =6.5A, I _{B1} =1.63A, I _{B2} =-3.25A	-	-	2.7	μs

2SC5516

■ Absolute Maximum Ratings

Parameter	Symbol	Rating	Unit
Collector to base voltage	V _{CB0}	1500	V
Collector to emitter voltage	V _{CES}	1500	V
Collector to emitter voltage	V _{CEO}	600	V
Emitter to base voltage	V _{EBO}	7	V
Peak collector current	I _{CP}	30 ^{*3}	A
Collector current	I _C	20	A
Base current	I _B	8	A
Collector power dissipation	P _C	70 ^{*1} 3.5 ^{*2}	W
Junction temperature	T _j	150	°C
Storage temperature	T _{stg}	-55 to +150	°C

*1)T_C=25°C *2)T_a=25°C (Without heat sink)

*3)Non-repetitive peak collector current.

■ Electrical Characteristics(T_C=25°C)

Parameter	Symbol	Conditions	min	typ	max	Unit
Collector cutoff current	I _{CB0}	V _{CB} =1000V, I _E =0	-	-	50	μA
	I _{CB0}	V _{CB} =1500V, I _E =0	-	-	1	mA
Emitter cutoff current	I _{EBO}	V _{EB} =7V, I _C =0	-	-	50	μA
Forward current transfer ratio	f _{FE}	V _{CE} =5V, I _C =10A	7	-	14	
Collector to emitter saturation voltage	V _{CE(sat)}	I _C =10A, I _B =2.5A	-	-	3	V
Base to emitter saturation voltage	V _{BE(sat)}	I _C =10A, I _B =2.5A	-	-	1.5	V
Transition frequency	f _T	V _{CE} =10V, I _C =0A, f=0.5MHz	-	3	-	MHz
Fall time	T _f	I _C =10A, I _{B1} =2.5A, I _{B2} =-5.0A	-	-	0.2	μs
Storage time	T _{stg}	I _C =10A, I _{B1} =2.5A, I _{B2} =-5.0A	-	-	2.7	μs

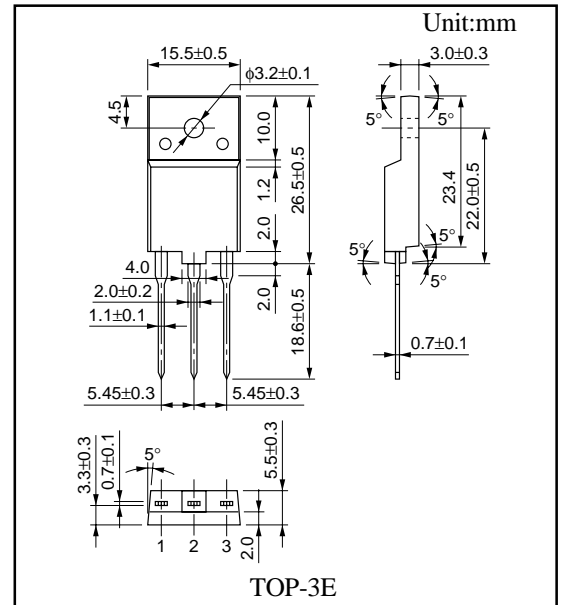

2SC5517

■ Absolute Maximum Ratings

Parameter	Symbol	Rating	Unit
Collector to base voltage	VCBO	1600	V
Collector to emitter voltage	VCEs	1600	V
Emitter to base voltage	VEBO	7	V
Peak collector current	ICP	20	A
Collector current	IC	6	A
Base current	IB	3	A
Collector power dissipation	PC	40 ^{*1} 3 ^{*2}	W
Junction temperature	Tj	130	°C
Storage temperature	Tstg	-55 to +150	°C

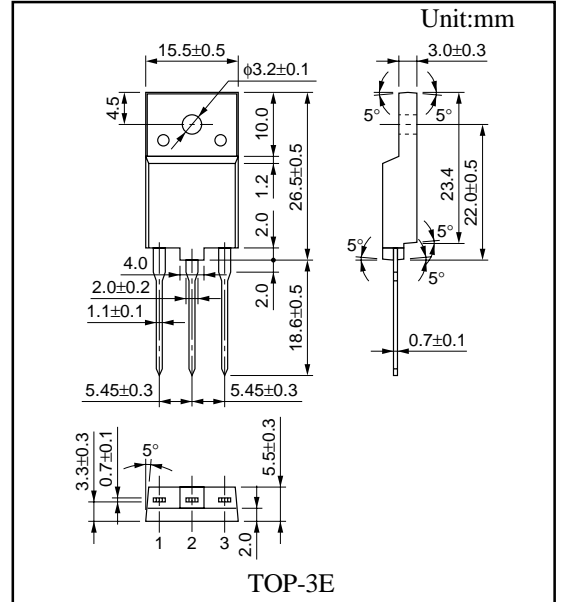

*1)TC=25°C ,*2)Ta=25°C(Without heat sink)
*3)Non-repetitive peak collector current.

■ Electrical Characteristics(TC=25°C)

Parameter	Symbol	Conditions	min	typ	max	Unit
Collector cutoff current	ICBO	VCB=1000V,IE=0	-	-	50	μA
	ICBO	VCB=1600V,IE=0	-	-	1	mA
Emitter to base voltage	VEBO	IE=500mA,IC=0	7	-	-	V
Forward current transfer ratio	fFE	VCE=5V,IC=1A	7	-	20	
Forward current transfer ratio	fFE	VCE=5V,IC=4A	4.5	-	8	
Collector to emitter saturation voltage	VCE(sat)	IC=4A,IB=0.8A	-	-	3	V
Base to emitter saturation voltage	VBE(sat)	IC=4A,IB=0.8A	-	-	1.5	V
Transition frequency	fT	VCE=10V,IC=0.1A,f=0.5MHz	-	3	-	MHz
Storage time	Tstg	IC=4.5A,IB1=0.9A,IB2=-1.8A	0.3	-	0.5	μs
Fall time	Tf	IC=4.5A,IB1=0.9A,IB2=-1.8A	3.8	-	5	μs
Diode characteristics	VF	IF=4A	-	-	-2	V

2SC5518

■ Absolute Maximum Ratings

Parameter	Symbol	Rating	Unit
Collector to base voltage	VCBO	1500	V
Collector to emitter voltage	VCEs	1500	V
Emitter to base voltage	VEBO	5	V
Peak collector current	ICP	14*3	A
Collector current	IC	7	A
Base current	IB	3.5	A
Collector power dissipation	PC	40*1 3*2	W
Junction temperature	Tj	150	°C
Storage temperature		-55 to +150	°C

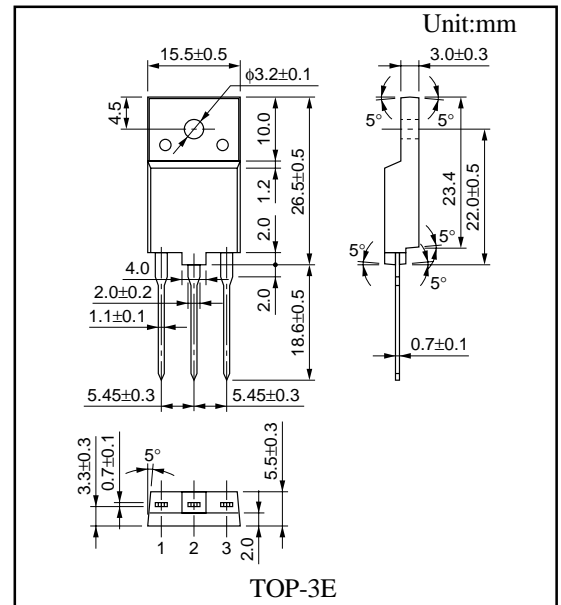

*1)TC=25°C ,*2)Ta=25°C(Without heat sink)

*3)Non-repetitive peak collector current.

■ Electrical Characteristics(TC=25°C)

Parameter	Symbol	Conditions	min	typ	max	Unit
Collector cutoff current	ICBO	VCB=1000V,IE=0	-	-	50	μA
	ICBO	VCB=1500V,IE=0	-	-	1	mA
Emitter to base voltage	VEBO	IE=500mA,IC=0	5	-	-	V
Forward current transfer ratio	fFE	VCE=5V,IC=5A	5	-	9	
Collector to emitter saturation voltage	VCE(sat)	IC=5A,IB=1A	-	-	3	V
Base to emitter saturation voltage	VBE(sat)	IC=5A,IB=1A	-	-	1.5	V
Transition frequency	fT	VCE=10V,IC=0.1A,f=0.5MHz	-	3	-	MHz
Storage time	Tstg	IC=5A,IB1=1A,IB2=2A	-	-	0.5	μs
Fall time	Tf	IC=5A,IB1=1A,IB2=2A	-	-	5	μs
Diode characteristics	VF	IF=5A	-	-	-2	V

2SC5519

■ Absolute Maximum Ratings

Parameter	Symbol	Rating	Unit
Collector to base voltage	VCBO	1700	V
Collector to emitter voltage	VCES	1700	V
Emitter to base voltage	VEBO	5	V
Peak collector current	ICP	16* ³	A
Collector current	IC	8	A
Base current	IB	3	A
Collector power dissipation	PC	50* ¹ 3* ²	W
Junction temperature	T _j	150	°C
Storage temperature		-55 to +150	°C

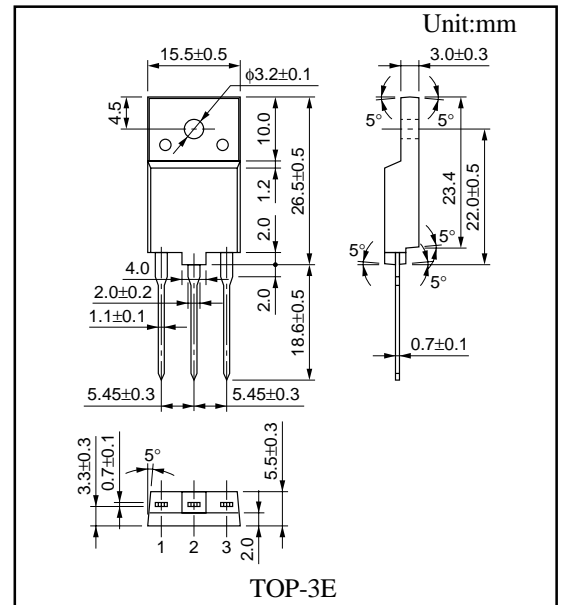

*1)TC=25°C ,*2)Ta=25°C(Without heat sink)

*3)Non-repetitive peak collector current.

■ Electrical Characteristics(TC=25°C)

Parameter	Symbol	Conditions	min	typ	max	Unit
Collector cutoff current	ICBO	V _{CB} =1000V,I _E =0	-	-	50	μA
	ICBO	V _{CB} =1700V,I _E =0	-	-	1	mA
Emitter to base voltage	VEBO	I _E =500mA,I _C =0	5	-	-	V
Forward current transfer ratio	f _{FE}	V _{CE} =5V,I _C =6A	5	-	10	
Collector to emitter saturation voltage	V _{CE(sat)}	I _C =6A,I _B =1.2A	-	-	3	V
Base to emitter saturation voltage	V _{BE(sat)}	I _C =6A,I _B =1.2A	-	-	1.5	V
Transition frequency	f _T	V _{CE} =10V,I _C =0.1A,f=0.5MHz	-	3	-	MHz
Storage time	T _{stg}	I _C =6A,I _{B1} =1.2A,I _{B2} =-2.4A	-	-	5.0	μs
Fall time	T _f	I _C =6A,I _{B1} =1.2A,I _{B2} =-2.4A	-	-	0.5	μs
Diode characteristics	V _F	I _F =6A	-	-	-2	V

2SC5572

■ Absolute Maximum Ratings

Parameter	Symbol	Rating	Unit
Collector to base voltage	V _{CB0}	1500	V
Collector to emitter voltage	V _{CES}	1500	V
Emitter to base voltage	V _{EBO}	7	V
Peak collector current	I _{CP}	12 ^{*3}	A
Collector current	I _C	6	A
Base current	I _B	3	A
Collector power dissipation	P _C	40 ^{*1} 3 ^{*2}	W
Junction temperature	T _j	150	°C
Storage temperature		-55 to +150	°C

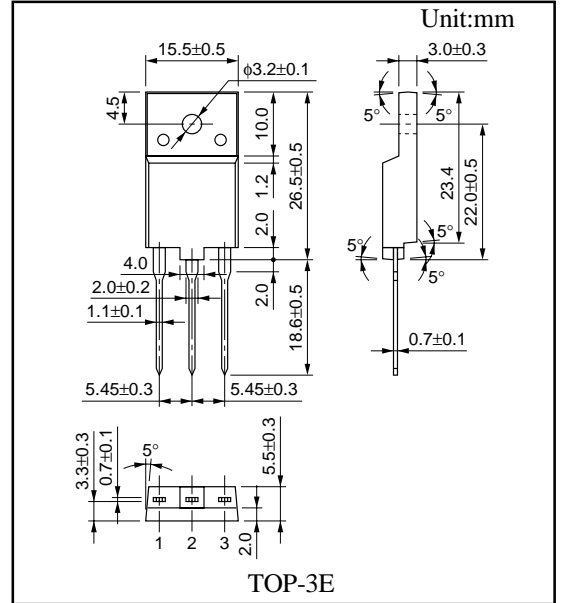

*1)TC=25°C ,*2)Ta=25°C(Without heat sink)

*3)Non-repetitive peak collector current.

■ Electrical Characteristics(TC=25°C)

Parameter	Symbol	Conditions	min	typ	max	Unit
Collector cutoff current	I _{CB0}	V _{CB} =1000V,I _E =0	-	-	50	μA
	I _{CB0}	V _{CB} =1500V,I _E =0	-	-	1	mA
Emitter to base voltage	V _{EBO}	I _E =500mA,I _C =0	7	-	-	V
Forward current transfer ratio	f _{FE}	V _{CE} =5V,I _C =4A	5	-	9	
Collector to emitter saturation voltage	V _{CE(sat)}	I _C =4A,I _B =0.8A	-	-	3	V
Base to emitter saturation voltage	V _{BE(sat)}	I _C =4A,I _B =0.8A	-	-	1.5	V
Transition frequency	f _T	V _{CE} =10V,I _C =0.1A,f=0.5MHz	-	3	-	MHz
Storage time	T _{stg}	I _C =4A,I _{B1} =0.8A,I _{B2} =-1.6A	-	-	5.0	μs
Fall time	T _f	I _C =4A,I _{B1} =0.8A,I _{B2} =-1.6A	-	-	0.5	μs
Diode characteristics	V _F	I _F =4A	-	-	-2	V

2SC5591

■ Absolute Maximum Ratings

Parameter	Symbol	Rating	Unit
Collector to base voltage	VCBO	1700	V
Collector to emitter voltage	VCES	1700	V
Collector to emitter voltage	VCEO	600	V
Emitter to base voltage	VEBO	7	V
Peak collector current	ICP	30*3	A
Collector current	IC	20	A
Base current	IB	11	A
Collector power dissipation	PC	70*1 3.5*2	W
Junction temperature	Tj	150	°C
Storage temperature	Tstg	-55 to +150	°C

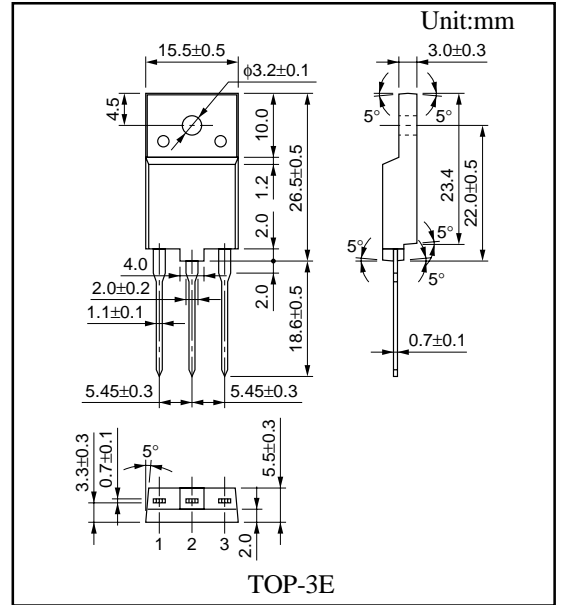

*1)TC=25°C *2)Ta=25°C (Without heat sink)

*3)Non-repetitive peak collector current.

■ Electrical Characteristics(TC=25°C)

Parameter	Symbol	Conditions	min	typ	max	Unit
Collector cutoff current	ICBO	V _{CB} =1000V, I _E =0	-	-	50	μA
	ICBO	V _{CB} =1700V, I _E =0	-	-	1	mA
Emitter cutoff current	IEBO	V _{EB} =7V, I _C =0	-	-	50	μA
Forward current transfer ratio	f _{FE}	V _{CE} =5V, I _C =10A	7	-	14	
Collector to emitter saturation voltage	V _{CE(sat)}	I _C =10A, I _B =2.5A	-	-	3	V
Base to emitter saturation voltage	V _{BE(sat)}	I _C =10A, I _B =2.5A	-	-	1.5	V
Transition frequency	f _T	V _{CE} =10V, I _C =0.1A, f=0.5MHz	-	3	-	MHz
Fall time	T _f	I _C =10A, I _{B1} =2.5A, I _{B2} =-5.0A	-	-	0.2	μs
Storage time	T _{stg}	I _C =10A, I _{B1} =2.5A, I _{B2} =-5.0A	-	-	3.0	μs

2SC5657

■ Absolute Maximum Ratings

Parameter	Symbol	Rating	Unit
Collector to base voltage	VCBO	1500	V
Collector to emitter voltage	VCEs	1500	V
Emitter to base voltage	VEBO	7	V
Peak collector current	ICP	8 ^{*3}	A
Collector current	IC	4	A
Base current	IB	2	A
Collector power dissipation	PC	40 ^{*1} 3 ^{*2}	W
Junction temperature	T _j	150	°C
Storage temperature		-55 to +150	°C

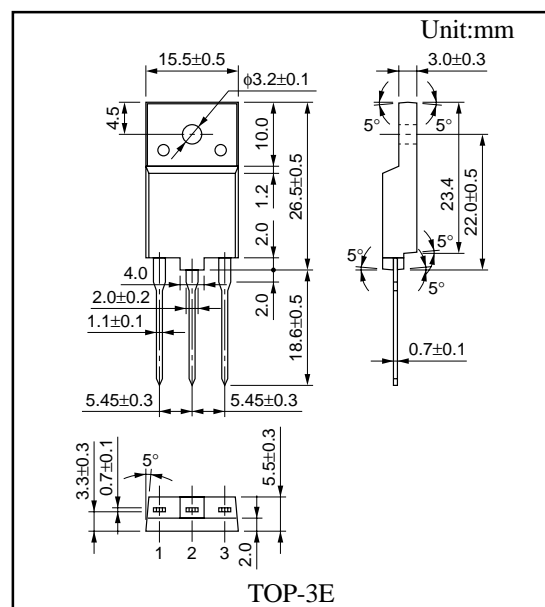

*1)TC=25°C ,*2)Ta=25°C(Without heat sink)

*3)Non-repetitive peak collector current.

■ Electrical Characteristics(TC=25°C)

Parameter	Symbol	Conditions	min	typ	max	Unit
Collector cutoff current	ICBO	V _{CB} =1000V, I _E =0	-	-	50	μA
	ICBO	V _{CB} =1500V, I _E =0	-	-	1	mA
Emitter to base voltage	VEBO	I _E =500mA, I _C =0	7	-	-	V
Forward current transfer ratio	f _{FE}	V _{CE} =5V, I _C =2A	5	-	9	
Collector to emitter saturation voltage	V _{CE(sat)}	I _C =2A, I _B =0.5A	-	-	5	V
Base to emitter saturation voltage	V _{BE(sat)}	I _C =2A, I _B =0.5A	-	-	1.5	V
Transition frequency	f _T	V _{CE} =10V, I _C =0.1A, f=0.5MHz	-	3	-	MHz
Storage time	T _{stg}	I _C =2A, I _{B1} =0.4A, I _{B2} =-0.8A	-	-	5.0	μs
Fall time	T _f	I _C =2A, I _{B1} =0.4A, I _{B2} =-0.8A	-	-	0.5	μs
Diode characteristics	V _F		-	-	-2	V

2SC5686

■ Absolute Maximum Ratings

Parameter	Symbol	Rating	Unit
Collector to base voltage	VCBO	2000	V
Collector to emitter voltage	VCES	2000	V
Collector to emitter voltage	VCEO	600	V
Emitter to base voltage	VEBO	7	V
Peak collector current	ICP	30*3	A
Collector current	IC	20	A
Base current	IB	11	A
Collector power dissipation	PC	70*1 3.5*2	W
Junction temperature	Tj	150	°C
Storage temperature	Tstg	-55 to +150	°C

*1)TC=25°C *2)Ta=25°C (Without heat sink)

*3)Non-repetitive peak collector current.

■ Electrical Characteristics(TC=25°C)

Parameter	Symbol	Conditions	min	typ	max	Unit
Collector cutoff current	ICBO	V _{CB} =1000V, I _E =0	-	-	50	μA
	ICBO	V _{CB} =2000V, I _E =0	-	-	1	mA
Emitter cutoff current	IEBO	V _{EB} =7V, I _C =0	-	-	50	μA
Forward current transfer ratio	f _{FE}	V _{CE} =5V, I _C =10A	7	-	14	
Collector to emitter saturation voltage	V _{CE(sat)}	I _C =10A, I _B =2.5A	-	-	3	V
Base to emitter saturation voltage	V _{BE(sat)}	I _C =10A, I _B =2.5A	-	-	1.5	V
Transition frequency	f _T	V _{CE} =10V, I _C =0.1A, f=0.5MHz	-	3	-	MHz
Fall time	T _f	I _C =10A, I _{B1} =2.5A, I _{B2} =-5.0A	-	-	0.2	μs
Storage time	T _{stg}	I _C =10A, I _{B1} =2.5A, I _{B2} =-5.0A	-	-	3.0	μs

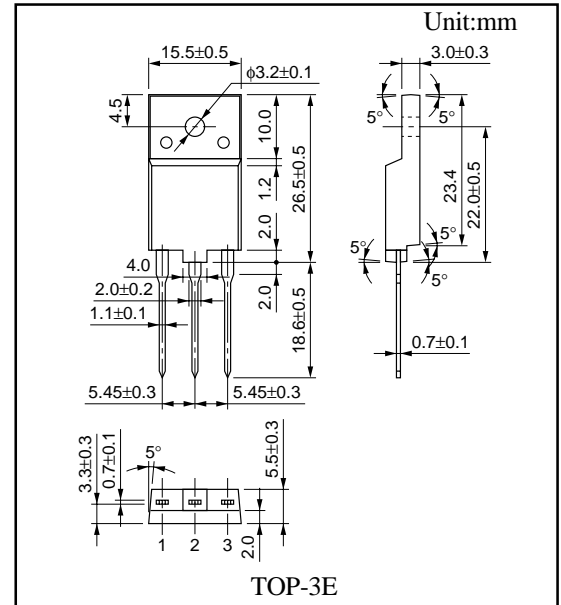

This datasheet has been downloaded from:

www.DatasheetCatalog.com

Datasheets for electronic components.



LittleDiode supplies new, hard to find or obsolete electronic components and semiconductors all over the world.

With over two million different components listed you are sure to find the part you need.

Feel free to visit us today at our online store:

LittleDiode.com

Looking forward to providing you with the best possible service.