

**2N2218A**

## Features

- Meets MIL 19500 /251
- Collector - Base Voltage 75V
- Collector - Current 800 mA
- Medium Current, Bipolar Transistor
- Available in TO-5

**SWITCHING  
 TRANSISTOR  
 JAN, JANTX, JANTXV**

**SMALL SIGNAL  
 BIPOLAR  
 NPN SILICON**

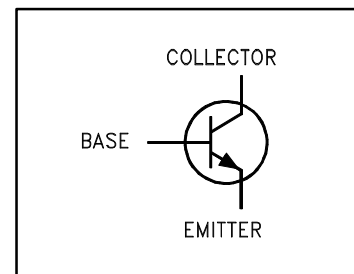
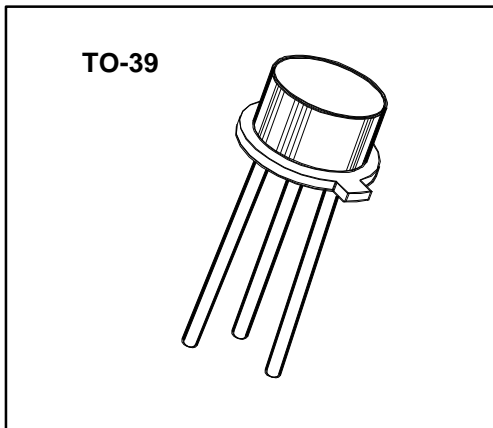

## Maximum Ratings

RATING	SYMBOL	VALUE	UNIT
Collector - Emitter Voltage	$V_{CEO}$	50	Vdc
Collector - Base Voltage	$V_{CBO}$	75	Vdc
Emitter - Base Voltage	$V_{EBO}$	6	Vdc
Collector Current - Continuous	$I_C$	800	mAdc
Total Device Dissipation @ $T_A = 25\text{ }^\circ\text{C}$	$P_D$	0.8	WATTS
Derate above $25\text{ }^\circ\text{C}$		4.6	mW/ $^\circ\text{C}$
Total Device Dissipation @ $T_C = 25\text{ }^\circ\text{C}$	$P_D$	3.0	WATTS
Derate above $25\text{ }^\circ\text{C}$		17.0	mW/ $^\circ\text{C}$
Operating Junction&Storage Temperature Range	$T_J, T_{stg}$	-55 to +200	$^\circ\text{C}$

## Thermal Characteristics

CHARACTERISTIC	SYMBOL	MAX	UNIT
Thermal Resistance, Junction to Ambient	$R\theta_{JA}$	217	$^\circ\text{C/W}$
Thermal Resistance, Junction to Case	$R\theta_{JC}$	59	$^\circ\text{C/W}$

Electrical Characteristics ( $T_A = 25^\circ\text{C}$  unless otherwise noted)

OFF CHARACTERISTIC	SYMBOL	MIN	MAX	UNIT
Collector - Emitter Breakdown Voltage (1) ( $I_C = 10 \text{ mA dc}, I_B = 0$ )	$V(\text{BR})_{\text{CEO}}$	50		Vdc
Collector - Base Breakdown Voltage ( $I_C = 10 \mu\text{Adc}, I_E = 0$ )	$V(\text{BR})_{\text{CBO}}$	75		Vdc
Emitter - Base Breakdown Voltage ( $I_E = 10 \mu\text{Adc}, I_C = 0$ )	$V(\text{BR})_{\text{EBO}}$	6		Vdc
Collector - Emitter Cutoff Current ( $V_{\text{CE}} = 50 \text{ Vdc}$ )	$I_{\text{CES}}$		10	nAdc
Collector - Base Cutoff Current ( $V_{\text{CB}} = 60 \text{ Vdc}, I_E = 0$ )	$I_{\text{CBO}}$		10	nAdc
( $V_{\text{CB}} = 60 \text{ Vdc}, I_E = 0, T_A = 150^\circ\text{C}$ )			10	$\mu\text{Adc}$
Emitter - Base Cutoff Current ( $V_{\text{EB}} = 4 \text{ Vdc}$ )	$I_{\text{EBO}}$		10	nAdc
( $V_{\text{EB}} = 6 \text{ Vdc}$ )			10	$\mu\text{Adc}$

ON CHARACTERISTIC	SYMBOL	MIN	MAX	UNIT
DC Current Gain	$h_{\text{FE}}$			
( $I_C = 0.1 \text{ mA dc}, V_{\text{CE}} = 10 \text{ Vdc}$ ) (1)		30		
( $I_C = 1 \text{ mA dc}, V_{\text{CE}} = 10 \text{ Vdc}$ ) (1)		35	150	
( $I_C = 10 \text{ mA dc}, V_{\text{CE}} = 10 \text{ Vdc}$ ) (1)		40		
( $I_C = 150 \text{ mA dc}, V_{\text{CE}} = 10 \text{ Vdc}$ ) (1)		40	120	
( $I_C = 500 \text{ mA dc}, V_{\text{CE}} = 10 \text{ Vdc}$ ) (1)		20		
( $I_C = 10 \text{ mA dc}, V_{\text{CE}} = 10 \text{ Vdc}, T_J = -55^\circ\text{C}$ ) (1)		35		
Collector - Emitter Saturation Voltage	$V_{\text{CE}(\text{sat})}$			
( $I_C = 150 \text{ mAdc}, I_B = 15 \text{ mAdc}$ ) (1)			0.3	Vdc
( $I_C = 500 \text{ mAdc}, I_B = 50 \text{ mAdc}$ ) (1)			1.0	Vdc
Base - Emitter Saturation Voltage	$V_{\text{BE}(\text{sat})}$			
( $I_C = 150 \text{ mAdc}, I_B = 15 \text{ mAdc}$ ) (1)		0.6	1.2	Vdc
( $I_C = 500 \text{ mAdc}, I_B = 50 \text{ mAdc}$ ) (1)			2.0	Vdc

1. Pulse Test: Pulse Width  $\leq 300 \mu\text{s}$ , Duty Cycle  $\leq 2\%$

# 2N2218A

**Electrical Characteristics** ( $T_A = 25^\circ\text{C}$  unless otherwise noted)

SMALL - SIGNAL CHARACTERISTICS	SYMBOL	MIN	MAX	UNIT
<b>Output Capacitance</b>	$C_{obo}$			
( $V_{CB} = 10 \text{ Vdc}$ , $I_E = 0$ , $100\text{kHz} \leq f \leq 1 \text{ MHz}$ )			8.0	pF
<b>Input Capacitance</b>	$C_{ibo}$			
( $V_{EB} = 0.5 \text{ Vdc}$ , $I_C = 0$ , $100\text{kHz} \leq f \leq 1 \text{ MHz}$ )			25	pF

SWITCHING CHARACTERISTICS	SYMBOL	MIN	MAX	UNIT
<b>Turn - On Time</b>	$t_{on}$			
( $V_{CC} = 30 \text{ Vdc}$ , $I_C = 150 \text{ mAdc}$ , $I_{B1} = 15 \text{ mAdc}$ ) ( See FIGURE 1 )			35	ns
<b>Turn - Off Time</b>	$t_{off}$			
( $V_{CC} = 30 \text{ Vdc}$ , $I_C = 150 \text{ mAdc}$ , $I_{B1} = -I_{B2} = 15 \text{ mAdc}$ ) ( See FIGURE 2 )			300	ns

**Small - Signal AC Characteristics** ( $T_A = 25^\circ\text{C}$ )

LOW FREQUENCY	SYMBOL	MIN	MAX	UNIT
<b>Common - Emitter Forward Current Transfer Ratio</b>	$h_{fe}$			
( $I_C = 1 \text{ mA}$ , $V_{CE} = 10 \text{ V}$ , $f = 1 \text{ kHz}$ )		35		
HIGH FREQUENCY				
<b>Common - Emitter Forward Current Transfer Ratio</b>	$ h_{fe} $			
( $I_C = 20 \text{ mA}$ , $V_{CE} = 20 \text{ V}$ , $f = 100 \text{ MHz}$ )		2.5	12	

**Spice Model** (based upon typical device characteristics) <sup>\*1</sup>

Q2N2218A NPN ( IS = 21.2f XTI = 3.0 EG = 1.11 VAF = 103.8 BF = 90.7 ISE = 3.34p  
 + NE = 2.05 IKF = 1.255 NK = 0.9394 XTB = 1.5 BR = 1.031 ISC = 3.299p  
 + NC = 1.605 IKR = 0.8992 RC = 0.0 CJC = 19.4p MJC = 0.3333 VJC = 0.75  
 + FC = 0.5 CJE = 29.6p MJE = 0.3333 VJE = 0.75 TR = 275.0 n TF = 564.5p  
 + ITF = 1.0 XTF = 0.0 VTF = 10.0 )

\*1. Microsemi Corp. claims no responsibility for misapplication of Spice Model information. Spice modeling should be used as a precursor guide to in-circuit performance. Actual performance is the responsibility of the user/designer.

**2N2218A**

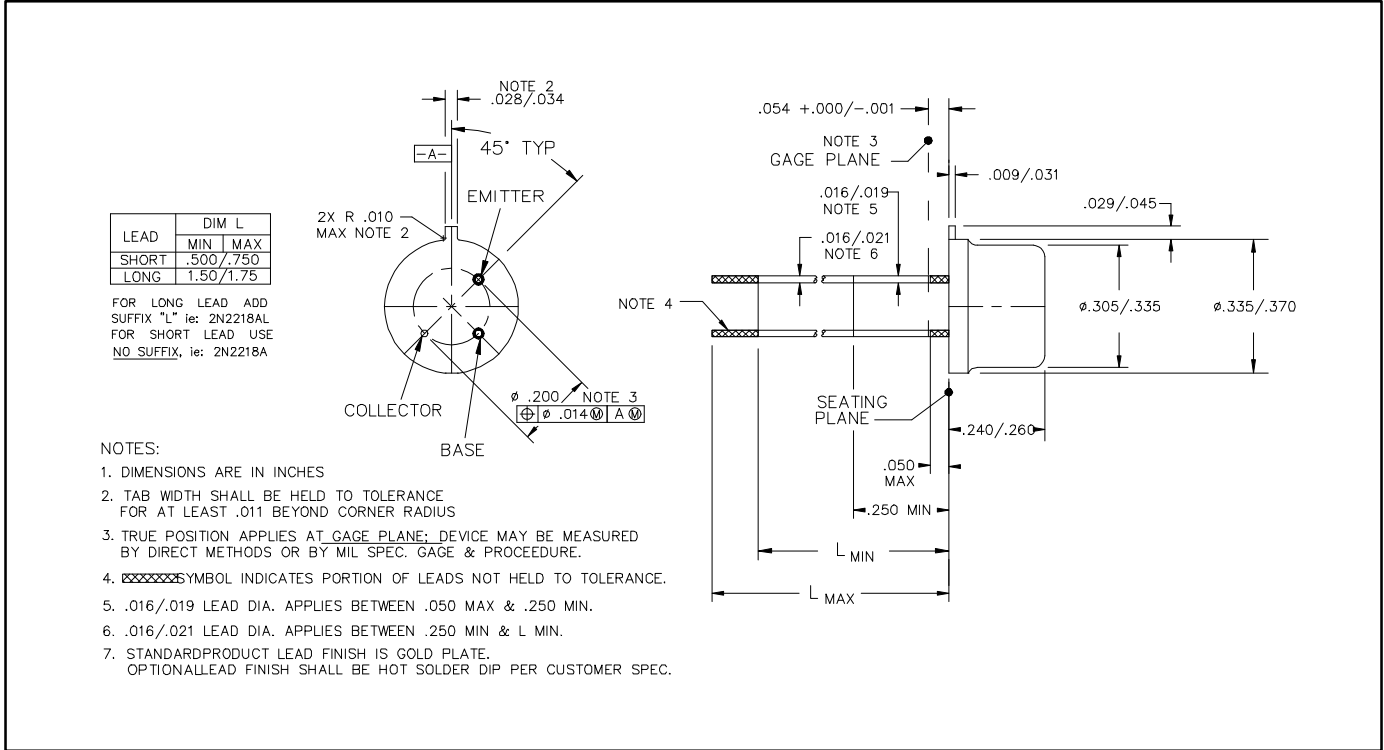

**TO-39 CASE OUTLINE**

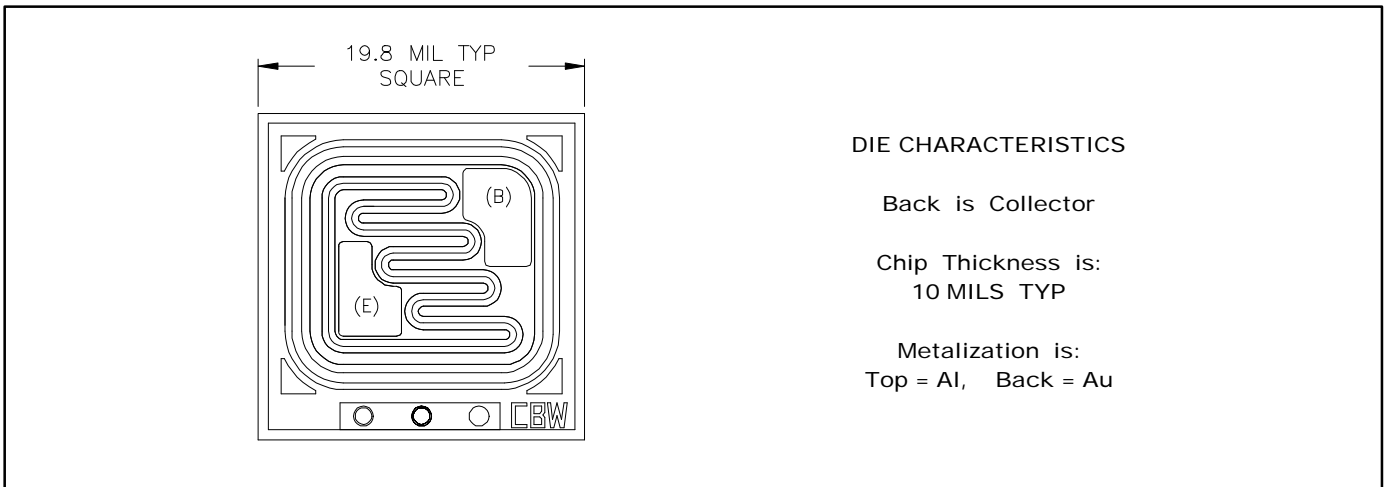

**DIE OUTLINE**

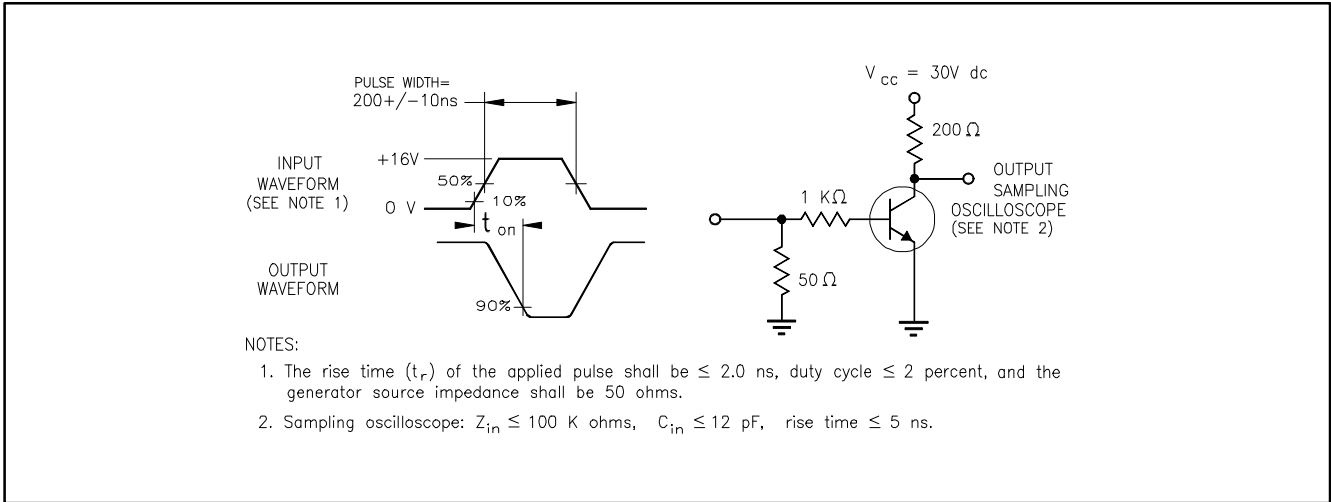

**FIGURE 1 Saturated Turn-on Time Test Circuit**

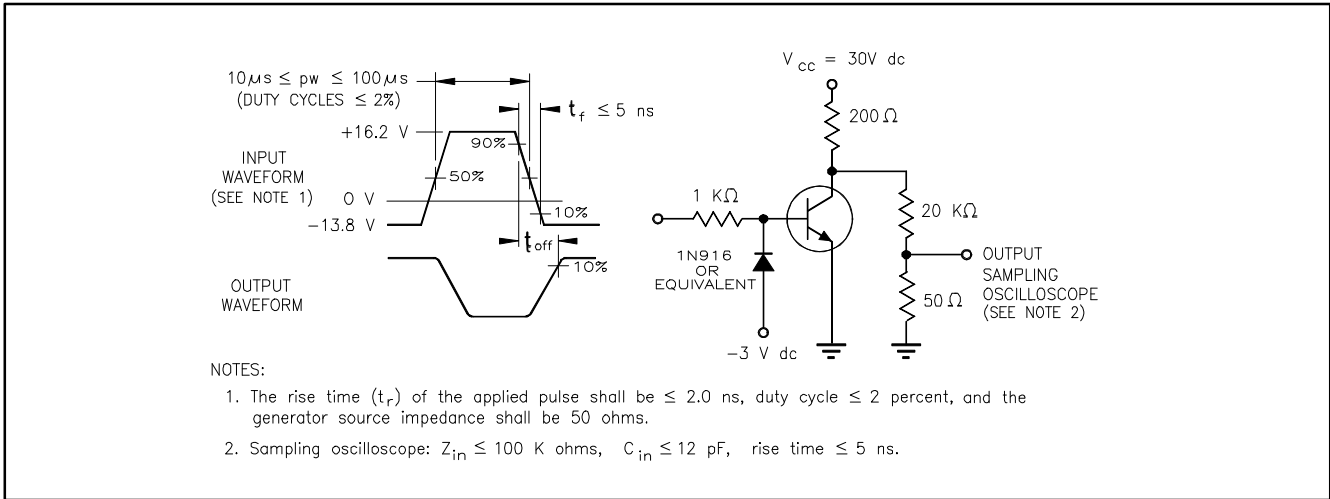

**FIGURE 2 Saturated Turn-off Time Test Circuit**

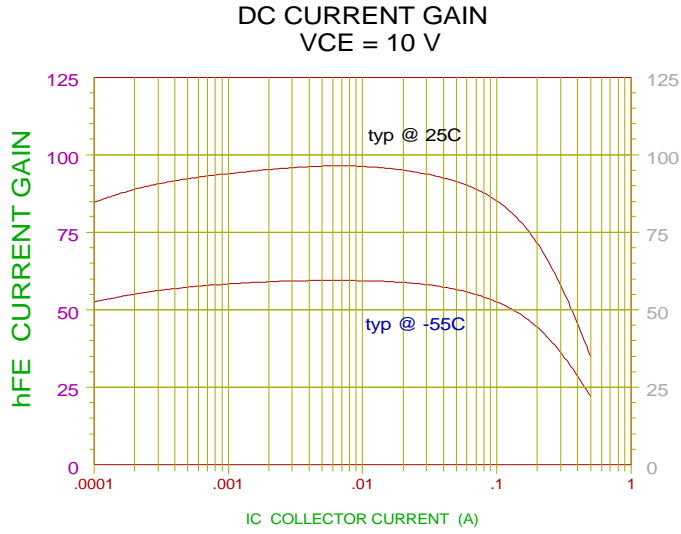

**FIGURE 3**

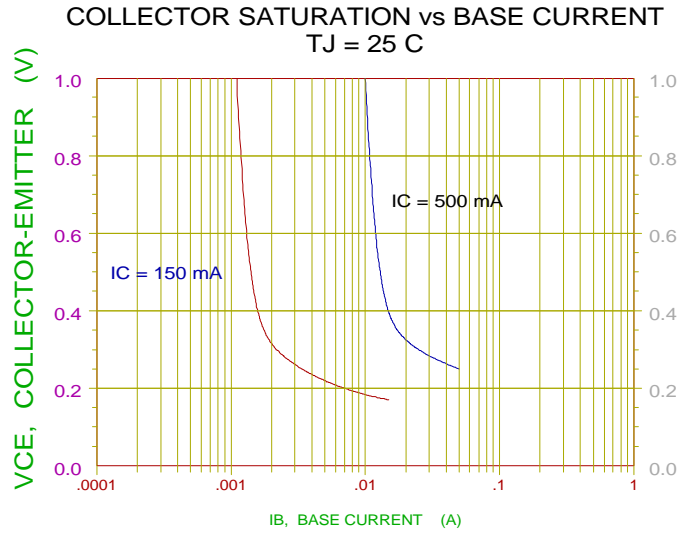

**FIGURE 4**

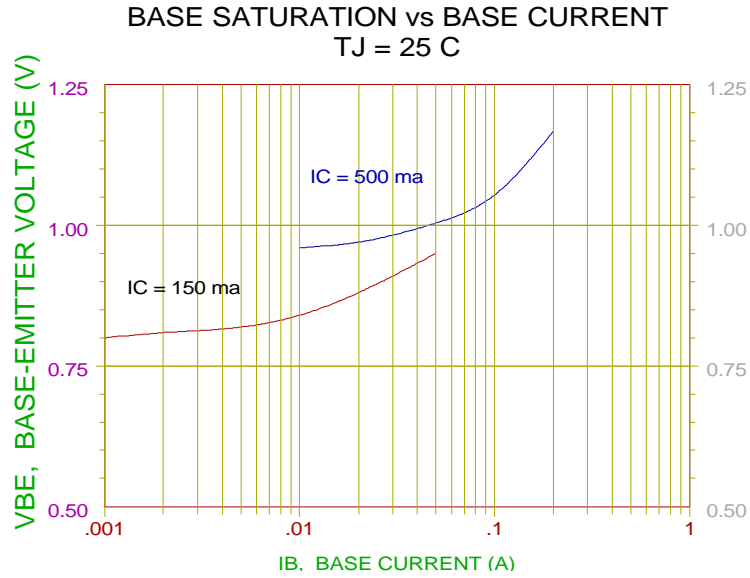

**FIGURE 5**

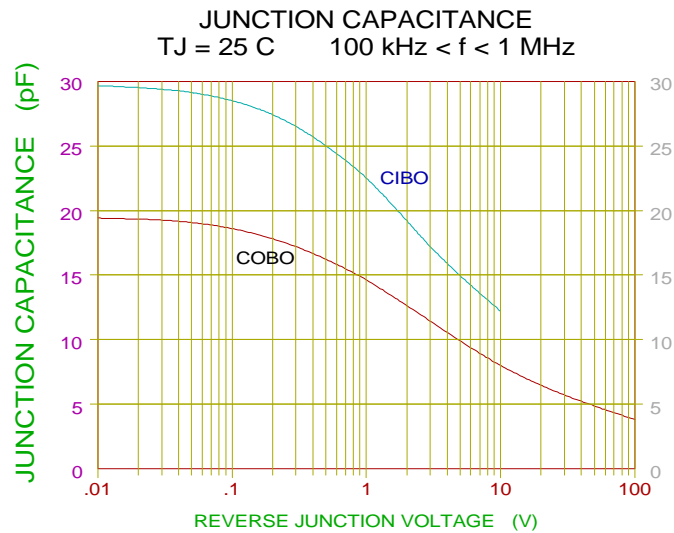

**FIGURE 6**

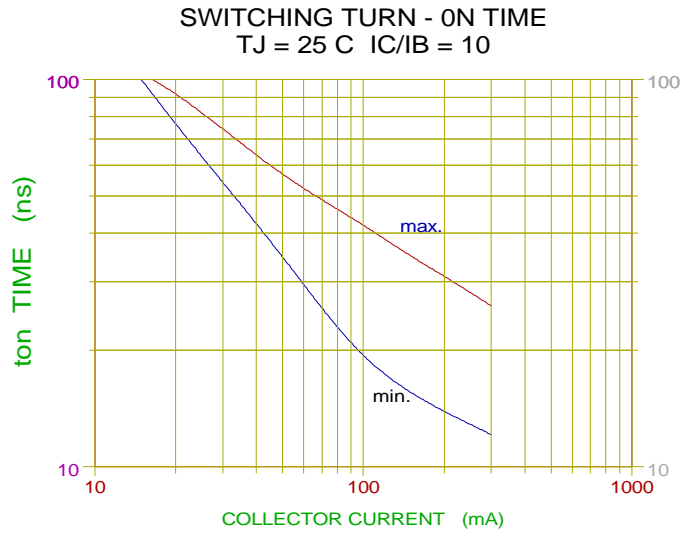

FIGURE 7

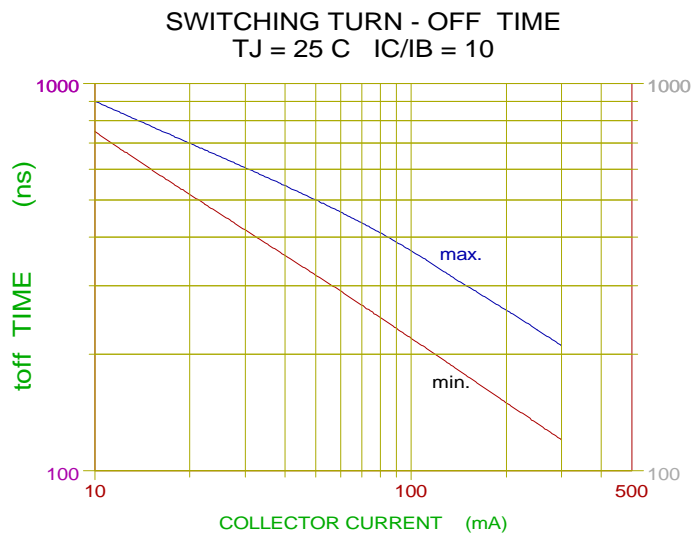
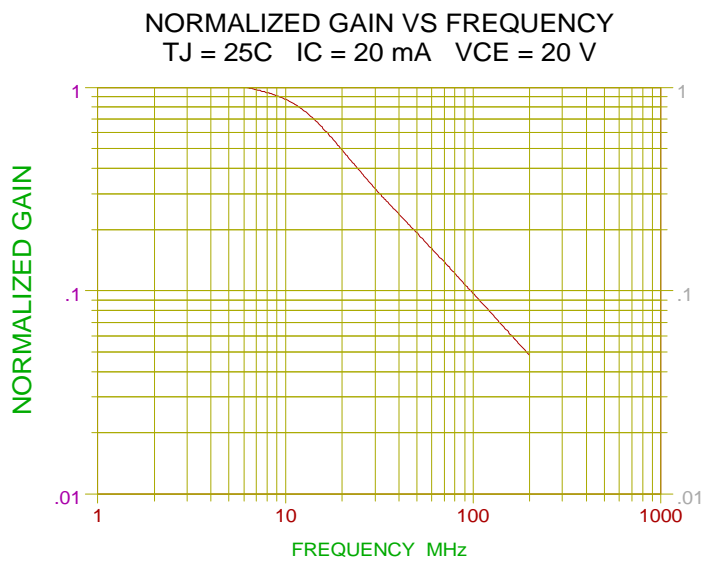

FIGURE 8



**FIGURE 9**



LittleDiode supplies new, hard to find or obsolete electronic components and semiconductors all over the world.

With over two million different components listed you are sure to find the part you need.

Feel free to visit us today at our online store:

[LittleDiode.com](http://LittleDiode.com)

Looking forward to providing you with the best possible service.