

2N2219

Features

- Meets MIL 19500 /251
- Collector - Base Voltage 60 V
- Collector - Current 800 mA
- Medium Current, Bipolar Transistor

**SWITCHING
 TRANSISTOR
 JAN, JANTX, JANTXV**

**SMALL SIGNAL
 BIPOLAR
 NPN SILICON**

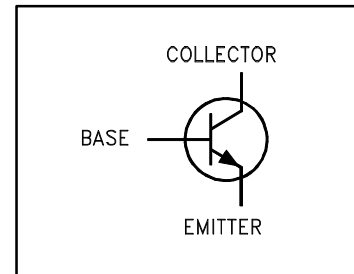
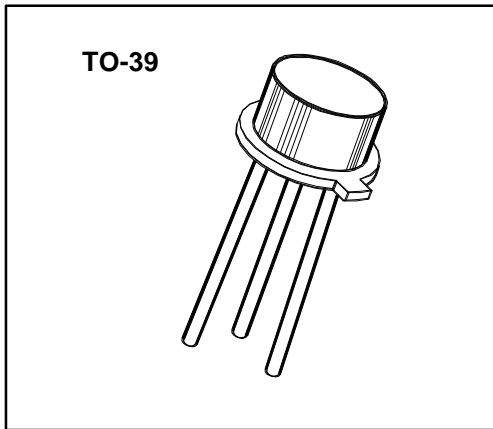

Maximum Ratings

RATING	SYMBOL	VALUE	UNIT
Collector - Emitter Voltage	V_{CEO}	30	Vdc
Collector - Base Voltage	V_{CBO}	60	Vdc
Emitter - Base Voltage	V_{EBO}	5	Vdc
Collector Current - Continuous	I_C	800	mAdc
Total Device Dissipation @ $T_A = 25\text{ }^\circ\text{C}$	P_D	0.8	WATTS
Derate above $25\text{ }^\circ\text{C}$		4.6	mW/ $^\circ\text{C}$
Total Device Dissipation @ $T_C = 25\text{ }^\circ\text{C}$	P_D	3.0	WATTS
Derate above $25\text{ }^\circ\text{C}$		17.0	mW/ $^\circ\text{C}$
Operating Junction & Storage Temperature Range	T_J, T_{stg}	-55 to +200	$^\circ\text{C}$

Thermal Characteristics

CHARACTERISTIC	SYMBOL	MAX	UNIT
Thermal Resistance, Junction to Ambient	$R\theta_{JA}$	217	$^\circ\text{C/W}$
Thermal Resistance, Junction to Case	$R\theta_{JC}$	59	$^\circ\text{C/W}$

2N2219

Electrical Characteristics ($T_A = 25^\circ\text{C}$ unless otherwise noted)

OFF CHARACTERISTIC	SYMBOL	MIN	MAX	UNIT
Collector - Emitter Breakdown Voltage (1) ($I_C = 10\text{ mA dc}, I_B = 0$)	$V(\text{BR})_{\text{CEO}}$	30		Vdc
Collector - Base Breakdown Voltage ($I_C = 10\ \mu\text{Adc}, I_E = 0$)	$V(\text{BR})_{\text{CBO}}$	60		Vdc
Emitter - Base Breakdown Voltage ($I_E = 10\ \mu\text{Adc}, I_C = 0$)	$V(\text{BR})_{\text{EBO}}$	5		Vdc
Collector - Emitter Cutoff Current ($V_{\text{CE}} = 30\text{ Vdc}$)	I_{CES}		10	nAdc
Collector - Base Cutoff Current ($V_{\text{CB}} = 50\text{ Vdc}, I_E = 0$)	I_{CBO}		10	nAdc
			10	μAdc
Emitter - Base Cutoff Current ($V_{\text{EB}} = 4\text{ Vdc}$)	I_{EBO}		10	nAdc
			10	μAdc

ON CHARACTERISTIC	SYMBOL	MIN	MAX	UNIT
DC Current Gain	h_{FE}			
($I_C = 0.1\text{ mA dc}, V_{\text{CE}} = 10\text{ Vdc}$) (1)		35		
($I_C = 1\text{ mA dc}, V_{\text{CE}} = 10\text{ Vdc}$) (1)		50	325	
($I_C = 10\text{ mA dc}, V_{\text{CE}} = 10\text{ Vdc}$) (1)		75		
($I_C = 150\text{ mA dc}, V_{\text{CE}} = 10\text{ Vdc}$) (1)		100	300	
($I_C = 500\text{ mA dc}, V_{\text{CE}} = 10\text{ Vdc}$) (1)		30		
($I_C = 10\text{ mA dc}, V_{\text{CE}} = 10\text{ Vdc}, T_J = -55^\circ\text{C}$) (1)		15		
Collector - Emitter Saturation Voltage	$V_{\text{CE(sat)}}$			
($I_C = 150\text{ mAdc}, I_B = 15\text{ mAdc}$) (1)			0.4	Vdc
($I_C = 500\text{ mAdc}, I_B = 50\text{ mAdc}$) (1)			1.6	Vdc
Base - Emitter Saturation Voltage	$V_{\text{BE(sat)}}$			
($I_C = 150\text{ mAdc}, I_B = 15\text{ mAdc}$) (1)		0.6	1.3	Vdc
($I_C = 500\text{ mAdc}, I_B = 50\text{ mAdc}$) (1)			2.6	Vdc

1. Pulse Test: Pulse Width $\leq 300\ \mu\text{s}$, Duty Cycle $\leq 2\%$

2N2219

Electrical Characteristics ($T_A = 25^\circ\text{C}$ unless otherwise noted)

SMALL - SIGNAL CHARACTERISTICS	SYMBOL	MIN	MAX	UNIT
Output Capacitance	C_{obo}			
($V_{CB} = 10 \text{ Vdc}$, $I_E = 0$, $100\text{kHz} \leq f \leq 1 \text{ MHz}$)			8.0	pF
Input Capacitance	C_{ibo}			
($V_{EB} = 0.5 \text{ Vdc}$, $I_C = 0$, $100\text{kHz} \leq f \leq 1 \text{ MHz}$)			25	pF

SWITCHING CHARACTERISTICS	SYMBOL	MIN	MAX	UNIT
Turn - On Time	t_{on}			
($V_{CC} = 30 \text{ Vdc}$, $I_C = 150 \text{ mAdc}$, $I_{B1} = 15 \text{ mAdc}$) (See FIGURE 1)			40	ns
Turn - Off Time	t_{off}			
($V_{CC} = 30 \text{ Vdc}$, $I_C = 150 \text{ mAdc}$, $I_{B1} = -I_{B2} = 15 \text{ mAdc}$) (See FIGURE 2)			250	ns

Small - Signal AC Characteristics ($T_A = 25^\circ\text{C}$)

LOW FREQUENCY	SYMBOL	MIN	MAX	UNIT
Common - Emitter Forward Current Transfer Ratio	h_{fe}			
($I_C = 1 \text{ mA}$, $V_{CE} = 10 \text{ V}$, $f = 1 \text{ kHz}$)		50		
HIGH FREQUENCY				
Common - Emitter Forward Current Transfer Ratio	$ h_{fe} $			
($I_C = 20 \text{ mA}$, $V_{CE} = 20 \text{ V}$, $f = 100 \text{ MHz}$)		2.5	12	

Spice Model (based upon typical device characteristics) *1

Q2N2219 NPN (IS = 21.2f XTI = 3.0 EG = 1.11 VAF = 157.4 BF = 196.6 ISE = 67.07 f
 + NE = 1.6 IKF = 1.537 NK = 1.02 XTb = 1.5 BR = 1.0 ISC = 1.709 p
 + NC = 1.437 IKR = 0.9876 RC = 0.0 CJC = 19.4p MJC = 0.3333 VJC = 0.75
 + FC = 0.5 CJE = 29.6p MJE = 0.3333 VJE = 0.75 TR = 300.2 n TF = 562.6p
 + ITF = 1.0 XTF = 0.0 VTF = 10.0)

*1. Microsemi Corp. claims no responsibility for misapplication of Spice Model information. Spice modeling should be used as a precursor guide to in-circuit performance. Actual performance is the responsibility of the user/designer.

2N2219

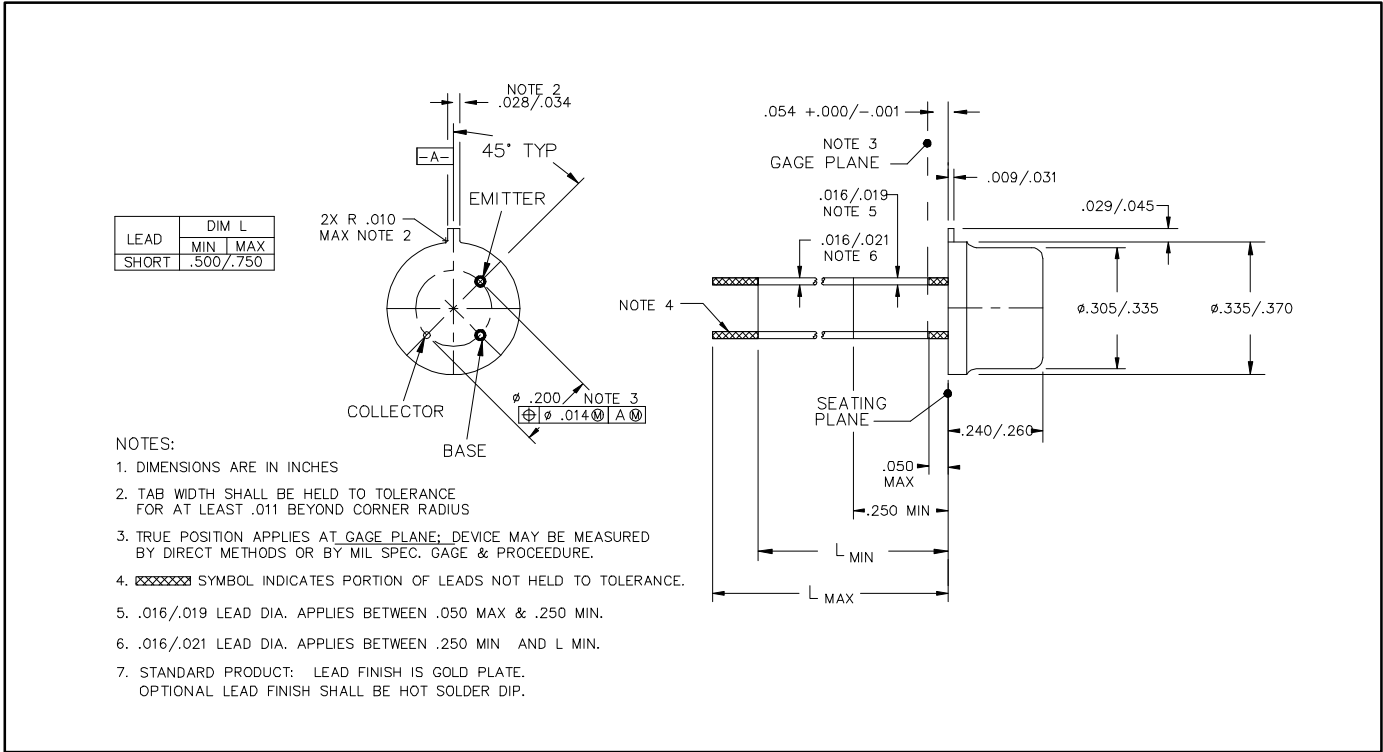

TO-39 CASE OUTLINE

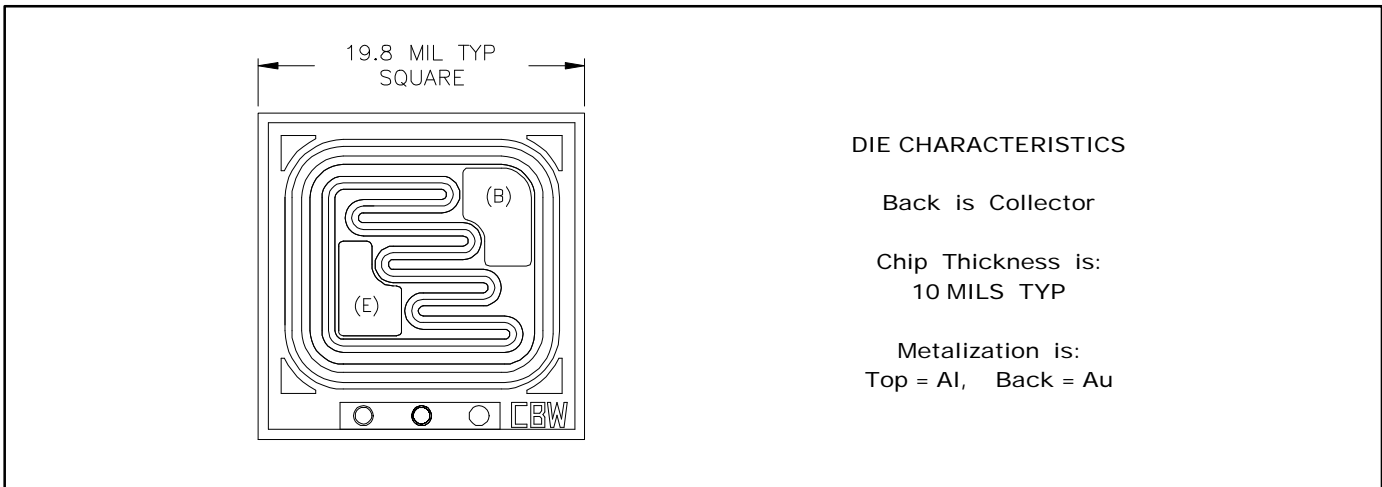

DIE OUTLINE

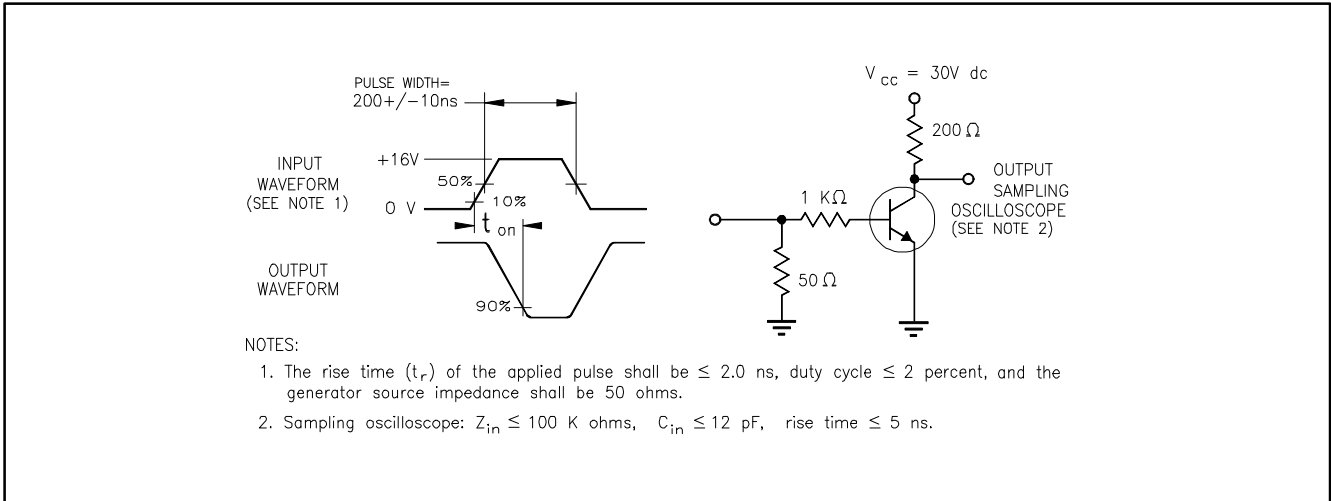

FIGURE 1 Saturated Turn-on Time Test Circuit

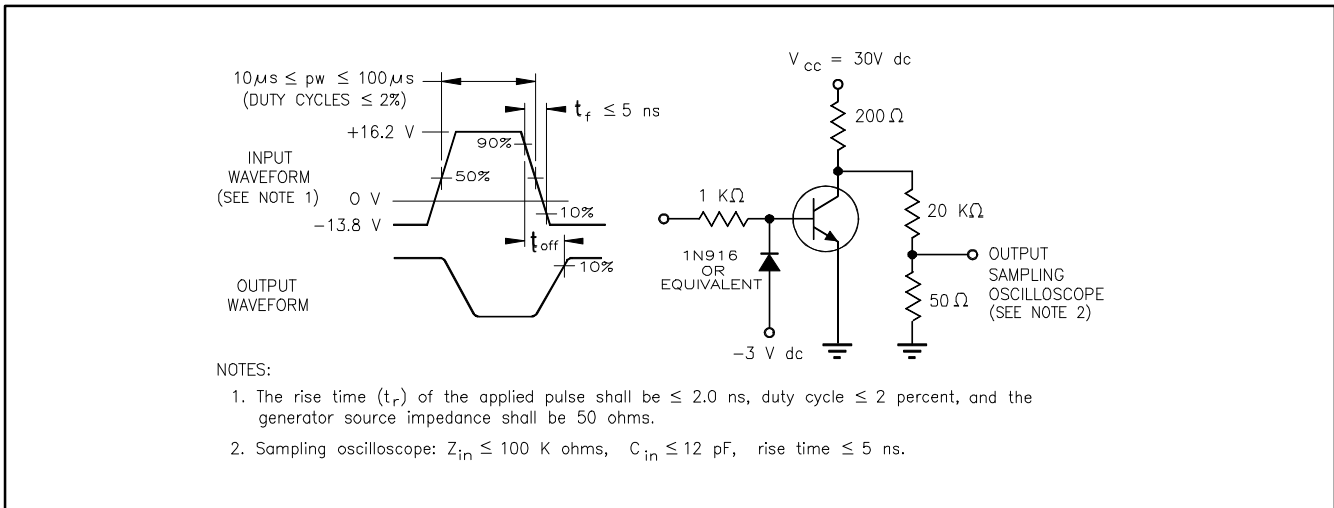

FIGURE 2 Saturated Turn-off Time Test Circuit

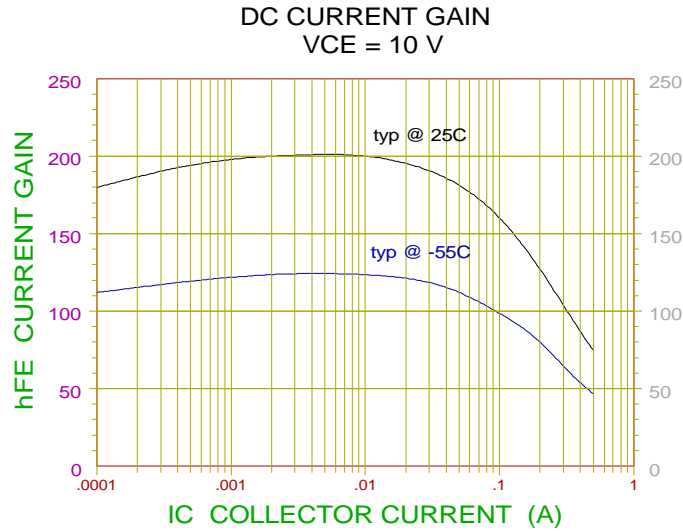

FIGURE 3

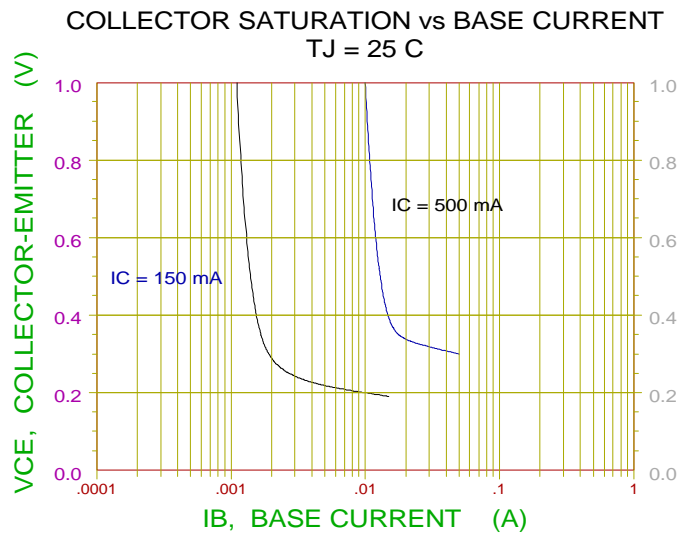

FIGURE 4

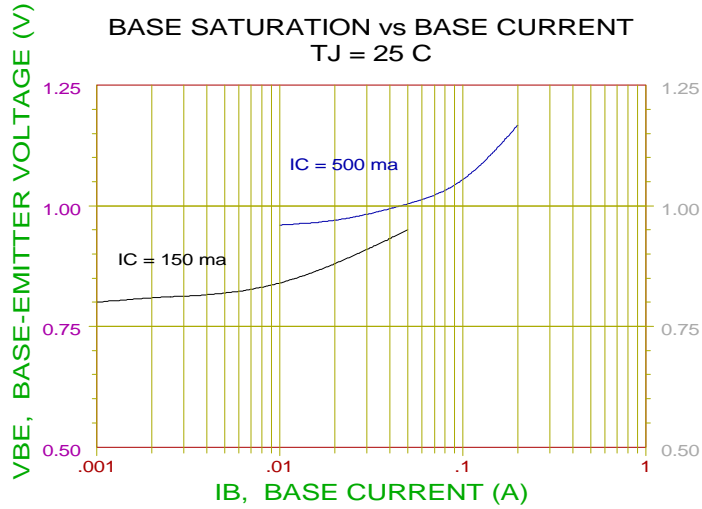

FIGURE 5

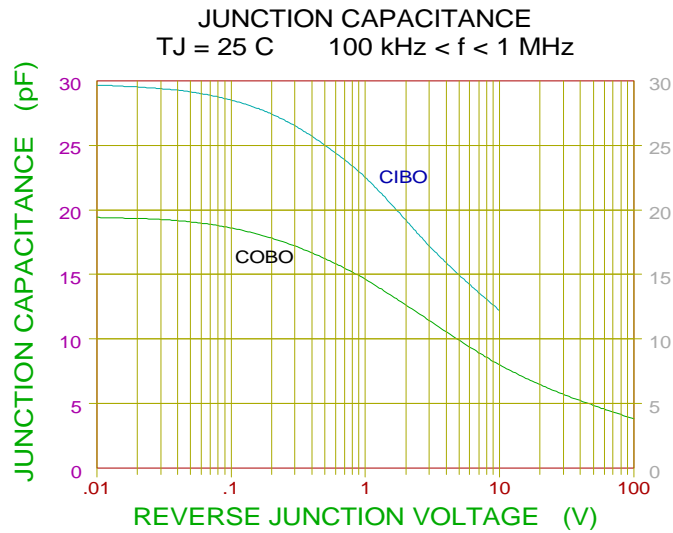

FIGURE 6

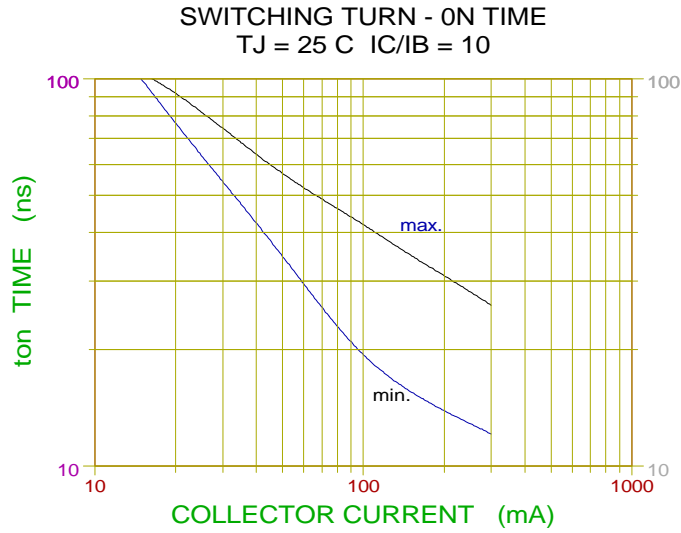

FIGURE 7

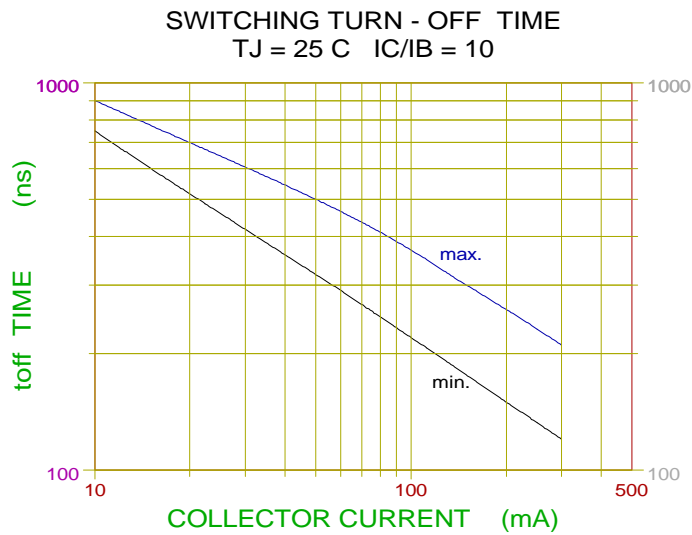

FIGURE 8

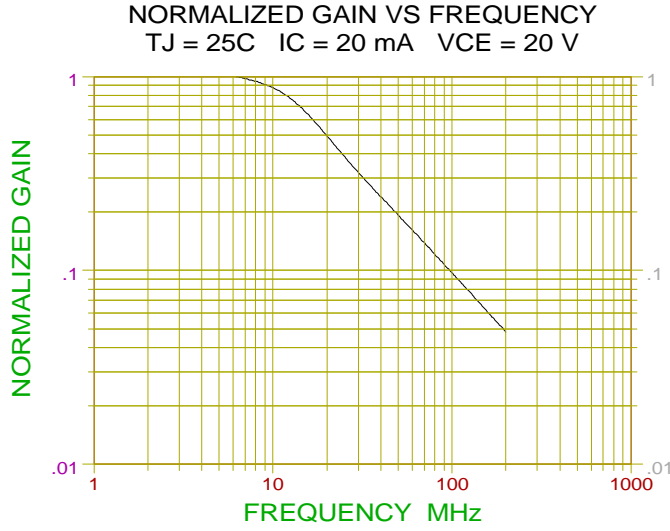

FIGURE 9



LittleDiode supplies new, hard to find or obsolete electronic components and semiconductors all over the world.

With over two million different components listed you are sure to find the part you need.

Feel free to visit us today at our online store:

LittleDiode.com

Looking forward to providing you with the best possible service.