

## LOW POWER NPN SILICON TRANSISTOR

Qualified per MIL-PRF-19500/391

### Devices

<b>2N3019</b>	<b>2N3057A</b>	<b>2N3700</b>
<b>2N3019S</b>		<b>2N3700S</b>

### Qualified Level

**JAN**  
**JANTX**  
**JANTXV**  
**JANS**

### MAXIMUM RATINGS

Ratings	Symbol	Value	Units
Collector-Emitter Voltage	$V_{CEO}$	80	Vdc
Collector-Base Voltage	$V_{CBO}$	140	Vdc
Emitter-Base Voltage	$V_{EBO}$	7.0	Vdc
Collector Current	$I_C$	1.0	Adc
Total Power Dissipation @ $T_A = +25^{\circ}C^{(1)}$	$P_T$	2N3019; 2N3019S	0.8
2N3057A		0.4	
2N3700		0.5	
2N3700UB		0.4	
@ $T_C = +25^{\circ}C^{(2)}$		2N3019; 2N3019S	5.0
2N3057A	1.8		
2N3700	1.8		
2N3700UB	1.16		
Operating & Storage Jct Temp Range	$T_J, T_{stg}$	-55 to +175	$^{\circ}C$

- Derate linearly 4.6 mW/ $^{\circ}C$  for type 2N3019 and 2N3019S; 2.3 mW/ $^{\circ}C$  for type 2N3057A; 2.85 mW/ $^{\circ}C$  for type 2N3700; 6.6 mW/ $^{\circ}C$  for type 2N3700UB for  $T_A \geq +25^{\circ}C$ .
- Derate linearly 28.6 mW/ $^{\circ}C$  for type 2N3019 and 2N3019S; 10.3 mW/ $^{\circ}C$  for types 2N3057A, 2N3700, & 2N3700UB for  $T_C \geq +25^{\circ}C$ .

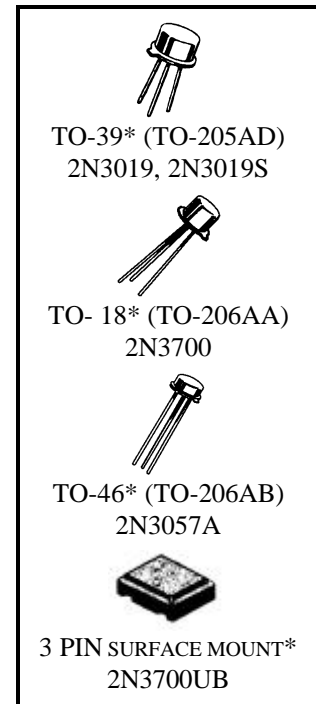

\*See appendix A for package outline

### ELECTRICAL CHARACTERISTICS ( $T_A = 25^{\circ}C$ unless otherwise noted)

Characteristics	Symbol	Min.	Max.	Unit
Collector-Base Breakdown Voltage $I_C = 100 \mu A_{dc}$	$V_{(BR)CBO}$	140		Vdc
Emitter-Base Breakdown Voltage $I_E = 100 \mu A_{dc}$	$V_{(BR)EBO}$	7.0		Vdc
Collector-Emitter Breakdown Current $I_C = 30 mA_{dc}$	$V_{(BR)CEO}$	80		Vdc

**ELECTRICAL CHARACTERISTICS (con't)**

Characteristics	Symbol	Min.	Max.	Unit
-----------------	--------	------	------	------

**OFF CHARACTERISTICS (con't)**

Collector-Emitter Cutoff Current $V_{CE} = 90 \text{ Vdc}$	$I_{CES}$		10	$\eta\text{Adc}$
Emitter-Base Cutoff Current $V_{EB} = 5.0 \text{ Vdc}$	$I_{EBO}$		10	$\eta\text{Adc}$

**ON CHARACTERISTICS (1)**

Forward-Current Transfer Ratio $I_C = 150 \text{ mAdc}, V_{CE} = 10 \text{ Vdc}$ $I_C = 0.1 \text{ mAdc}, V_{CE} = 10 \text{ Vdc}$ $I_C = 10 \text{ mAdc}, V_{CE} = 10 \text{ Vdc}$ $I_C = 500 \text{ mAdc}, V_{CE} = 10 \text{ Vdc}$ $I_C = 1.0 \text{ Adc}, V_{CE} = 10 \text{ Vdc}$	$h_{FE}$	100 50 90 50 15	300 200 200	
Collector-Emitter Saturation Voltage $I_C = 150 \text{ mAdc}, I_B = 15 \text{ mAdc}$ $I_C = 500 \text{ mAdc}, I_B = 50 \text{ mAdc}$	$V_{CE(sat)}$		0.2 0.5	Vdc
Base-Emitter Saturation Voltage $I_C = 150 \text{ mAdc}, I_B = 15 \text{ mAdc}$	$V_{BE(sat)}$		1.1	Vdc

**DYNAMIC CHARACTERISTICS**

Small-Signal Short-Circuit Forward Current Transfer Ratio $I_C = 1.0 \text{ mAdc}, V_{CE} = 5.0 \text{ Vdc}, f = 1.0 \text{ kHz}$	$h_{fe}$	80	400	
Magnitude of Small-Signal Short-Circuit Forward Current Transfer Ratio $I_C = 50 \text{ mAdc}, V_{CE} = 10 \text{ Vdc}, f = 20 \text{ MHz}$	$ h_{fe} $	5.0	20	
Output Capacitance $V_{CB} = 10 \text{ Vdc}, I_E = 0, 100 \text{ kHz} \leq f \leq 1.0 \text{ MHz}$	$C_{obo}$		12	$p^f$
Input Capacitance $V_{EB} = 0.5 \text{ Vdc}, I_C = 0, 100 \text{ kHz} \leq f \leq 1.0 \text{ MHz}$	$C_{ibo}$		60	pF

**SAFE OPERATING AREA**

<b>DC Tests</b> $T_C = 25^{\circ}\text{C}, 1 \text{ Cycle}, t = 10 \text{ ms}$	
<b>Test 1</b>	$V_{CE} = 10 \text{ Vdc}$
2N3019, 2N3019S	$I_C = 500 \text{ mAdc}$
2N3057A, 2N3700, 2N3700UB	$I_C = 180 \text{ mAdc}$
<b>Test 2</b>	$V_{CE} = 40 \text{ Vdc}$
2N3019, 2N3019S	$I_C = 125 \text{ mAdc}$
2N3057A, 2N3700, 2N3700UB	$I_C = 45 \text{ mAdc}$
<b>Test 3</b>	$V_{CE} = 80 \text{ Vdc}$
2N3019, 2N3019S	$I_C = 60 \text{ mAdc}$
2N3057A, 2N3700, 2N3700UB	$I_C = 22.5 \text{ mAdc}$

(1) Pulse Test: Pulse Width = 300 $\mu\text{s}$ , Duty Cycle  $\leq 2.0\%$ .



LittleDiode supplies new, hard to find or obsolete electronic components and semiconductors all over the world.

With over two million different components listed you are sure to find the part you need.

Feel free to visit us today at our online store:

[LittleDiode.com](http://LittleDiode.com)

Looking forward to providing you with the best possible service.