

128Mb DDR SDRAM

DDR SDRAM Specification Version 1.0

128Mb DDR SDRAM

Revision History

Version 0 (May, 1998)

- First version for internal review

Version 0.1(June, 1998)

- Added x4 organization

Version 0.2(Sep,1998)

1. Added "Issue prcharge command for all banks of the device" as the fourth step of power-up squence.
2. In power down mode timing diagram, NOP condition is added to precharge power down exit.

Version 0.3(Dec,1998)

- Added QFC Function.
- Added DC current value
- Reduce I/O capacitance values

Version 0.4(Feb,1999)

- Added DDR SDRAM history for reference(refer to the following page)
- Added low power version DC spec

Version 0.5(Apr,1999)

- Revised following first showing for JEDEC standard
- Added DC target current based on new DC test condition

Version 0.6(July 1,1999)

- 1.Modified binning policy

From	To
-Z (133Mhz)	-Z (133Mhz/266Mbps@CL=2)
-8 (125Mhz)	-Y (133Mhz/266Mbps@CL=2.5)
-0 (100Mhz)	-0 (100Mhz/200Mbps@CL=2)

- 2.Modified the following AC spec values

	From.		To.		
	-Z	-0	-Z	-Y	-0
tAC	+/- 0.75ns	+/- 1ns	+/- 0.75ns	+/- 0.75ns	+/- 0.8ns
tDQSK	+/- 0.75ns	+/- 1ns	+/- 0.75ns	+/- 0.75ns	+/- 0.8ns
tDQSQ	+/- 0.5ns	+/- 0.75ns	+/- 0.5ns	+/- 0.5ns	+/- 0.6ns
tDS/tDH	0.5 ns	0.75 ns	0.5 ns	0.5 ns	0.6 ns
tCDLR ^{*1}	2.5tCK-tDQSS	2.5tCK-tDQSS	1tCK	1tCK	1tCK
tPRE ^{*1}	1tCK +/- 0.75ns	1tCK +/- 1ns	0.9/1.1 tCK	0.9/1.1 tCK	0.9/1.1 tCK
tRPST ^{*1}	tCK/2 +/- 0.75ns	tCK/2 +/- 1ns	0.4/0.6 tCK	0.4/0.6 tCK	0.4/0.6 tCK
tHZQ ^{*1}	tCK/2 +/- 0.75ns	tCK/2 +/- 1ns	+/- 0.75ns	+/- 0.75ns	+/-0.8ns

*1 : Changed description method for the same functionality. This means no difference from the previous version.

- 3.Changed the following AC parameter symbol

	From.	To.
Output data access time from $\overline{CK/CK}$	tDQCK	tAC

Version 0.61(August 9,1999)

- Changed the some values of "write with auto precharge" table for different bank in page 31.

Asserted command	For Different Bank			
	3		4	
	Old	New	Old	New
Read	Legal	Illegal	Legal	Illegal
Read + AP ^{*1}	Legal	Illegal	Legal	Illegal

128Mb DDR SDRAM

Revision History(continued)

Version 0.7 (March, 2000)

- Changed 128Mb spec from target to Preliminary version.
- Changed partnames as follows.

from	to
KM44L32031BT-G(L)Z/Y/0	K4H280438B-TC(L)A2/B0/A0
KM48L16031BT-G(L)Z/Y/0	K4H280838B-TC(L)A2/B0/A0
KM416L8031BT-G(L)Z/Y/0	K4H281638B-TC(L)A2/B0/A0

- Changed input cap. spec.

	from	to
CK/CK	2.5pF ~ 3.5pF	2.0pF ~ 3.0pF w/ Delta Cin = 0.25pF
DQ/DQS/DM	4.0pF ~ 5.5pF	4.0pF ~ 5.0pF w/ Delta Cin = 0.5pF
CMD/Addr	2.5pF ~ 3.5pF	2.0pF ~ 3.0pF with Delta Cin = 0.5pF

- Changed operating condition.

	from	to
Vil/Vih(ac)	Vref +/- 0.35V	Vref +/- 0.31V
V _{IL} /V _{IH} (dc)	Vref +/- 0.18V	Vref +/- 0.15V

- Added Overshoot/Undershoot spec
 - . Vih(max) = 4.2V, the overshoot voltage duration is ≤ 3ns at VDD.
 - . Vil(min) = -1.5V, the overshoot voltage duration is ≤ 3ns at VSS.

- Changed AC parameters as follows.

	from	to	Comments
tDQSQ	+/- 0.5(PC266), +/- 0.6(PC200)	+0.5(PC266), +0.6(PC200)	
tDV	+/- 0.35tCK	-	Removed
tQH	-	tHPmin - 0.75ns(PC266)	New Definition
		tHPmin - 1.0ns(PC200)	
tHP	-	tCLmin or tCHmin	New Definition

- Added DC spec values.

Version 0.71 (April, 2000)

- Corrected a typo for tRAS at 133Mhz/CL2.5 from 48ns to 45ns.
- Corrected a typo in "General Information" table from 64Mx4 to 8Mx16.

Version 0.72(May,2000)

- Changed DC spec item & test condition

Version 0.73(June,2000)

- Added updated DC spec values
- Deleted tDAL in AC parameter

Version 1.0(November,2000)

- Eliminate "preliminary"

128Mb DDR SDRAM

Contents

Revision History	2
General Information	9
1. Key Features	10
1.1 Features	10
1.2 Operating Frequencies	10
2. Package Pinout & Dimension	11
2.1 Package Pinout	11
2.2 Input/Output Function Description	12
2.3 66 Pin TSOP(II)/MS-024FC Package Physical Dimension	13
3. Functional Description	14
3.1 Simplified State Diagram	14
3.2 Basic Functionality	15
3.2.1 Power-Up Sequence	15
3.2.2 Mode Register Definition	16
3.2.2.1 Mode Register Set(MRS)	16
3.2.2.2 Extended Mode Register Set(EMRS)	18
3.2.3 Precharge	19
3.2.4 No Operation(NOP) & Device Deselect	19
3.2.5 Row Active	20
3.2.6 Read Bank	20
3.2.7 Write Bank	20
3.3 Essential Functionality for DDR SDRAM	21
3.3.1 Burst Read Operation	22
3.3.2 Burst Write Operation	23
3.3.3 Read Interrupted by a Read	23
3.3.4 Read Interrupted by a Write & Burst Stop	24
3.3.5 Read Interrupted by a Precharge	24
3.3.6 Write Interrupted by a Write	25

128Mb DDR SDRAM

3.3.7 Write Interrupted by a Read & DM	26
3.3.8 Write Interrupted by a Precharge & DM	27
3.3.9 Burst Stop	28
3.3.10 DM masking	29
3.3.11 Read With Auto Precharge	30
3.3.12 Write With Auto Precharge	31
3.3.13 Auto Refresh & Self Refresh	32
3.3.14 Power Down	33
4. Command Truth Table	34
5. Functional Truth Table	35
6. Absolute Maximum Rating	40
7. DC Operating Conditions & Specifications	40
7.1 DC Operating Conditions	41
7.2 DC Specifications	
8. AC Operating Conditions & Timming Specification	42
8.1 AC Operating Conditions	42
8.2 AC Timming Parameters & Specification	43
9. AC Operating Test Conditions	45
10. Input/Output Capacitance	45
11. IBIS: I/V Characteristics for Input and Output Buffers	46
11.1 Normal strength driver	46
11.2 Half strength driver(will be included in the future)	48
12. \overline{QFC} function	
\overline{QFC} definition	49
\overline{QFC} timing on Read Operation	49
\overline{QFC} timing on Write operation with $tDQSS_{max}$	49
\overline{QFC} timing on Write operation with $tDQSS_{min}$	50
\overline{QFC} timing example for interrupted writes operation	51
Timing Diagram	52

128Mb DDR SDRAM

List of tables

Table 1 : Operating frequency and DLL jitter	10
Table 2. : Column address configuration	11
Table 3 : Input/Output function description	12
Table 4 : Burst address ordering for burst length	17
Table 5 : Bank selection for precharge by bank address bits	19
Table 6 : Operating description when new command asserted while read with auto precharge is issued	30
Table 7 : Operating description when new command asserted while write with auto precharge is issued	31
Table 8 : Command truth table	34
Table 9-1 : Functional truth table	35
Table 9-2 : Functional truth table (continued)	36
Table 9-3 : Functional truth table (continued)	37
Table 9-4 : Functional truth table (continued)	38
Table 9-5 : Functional truth table (continued)	39
Table 10 : Absolute maximum ratings	40
Table 11 : DC operating condition	40
Table 12 : DC specification	42
Table 13 : AC operating condition	42
Table 14 : AC timing parameters and specifications	44
Table 15 : AC operating test conditions	45
Table 16 : Input/Output capacitance	45
Table 17 : Pull down and pull up current values	47

128Mb DDR SDRAM

List of figures

Figure 1 : 128Mb Package Pinout	11
Figure 2 : Package dimension	13
Figure 3 : State digram	14
Figure 4 : Power up and initialization sequence	15
Figure 5 : Mode register set	16
Figure 6 : Mode register set sequence	17
Figure 7 : Extend mode register set	18
Figure 8 : Bank activation command cycle timing	20
Figure 9 : Burst read operation timing	21
Figure 10 : Burst write operation timing	22
Figure 11 : Read interrupted by a read timing	23
Figure 12 : Read interrupted by a write and burst stop timing	23
Figure 13 : Read interrupted by a precharge timing	24
Figure 14 : Write interrupted by a write timing	25
Figure 15 : Write interrupted by a read and DM timing	26
Figure 16 : Write interrupted by a precharge and DM timing	27
Figure 17 : Burst stop timing	28
Figure 18 : DM masking timing	29
Figure 19 : Read with auto precharge timing	30
Figure 20 : Write with auto precharge timing	31
Figure 21 : Auto refresh timing	32
Figure 22 : Self refresh timing	32
Figure 23 : Power down entry and exit timing	33
Figure 24 : Output Load Circuit (SSTL_2)	45
Figure 25 : I / V characteristics for input/output buffers: <u> </u> pull-up(above) and pull-down(below)	46
Figure 26 : <u>QFC</u> timing on read operation	49
Figure 27 : <u>QFC</u> timing on write operation with tDQSSmax	50
Figure 28 : <u>QFC</u> timing on write operation with tDQSSmin	50
Figure 29 : QFC timing example for interrupted writes operation	51

128Mb DDR SDRAM

General Information

Organization	133Mhz w/ CL=2	133Mhz w/ CL=2.5	100Mhz w/ CL=2
32Mx4	K4H280438B-TCA2	K4H280438B-TCB0	K4H280438B-TCA0
	K4H280438B-TLA2	K4H280438B-TLB0	K4H280438B-TLA0
16Mx8	K4H280838B-TCA2	K4H280838B-TCB0	K4H280838B-TCA0
	K4H280838B-TLA2	K4H280838B-TLB0	K4H280838B-TLA0
8Mx16	K4H281638B-TCA2	K4H281638B-TCB0	K4H281638B-TCA0
	K4H281638B-TLA2	K4H281638B-TLB0	K4H281638B-TLA0

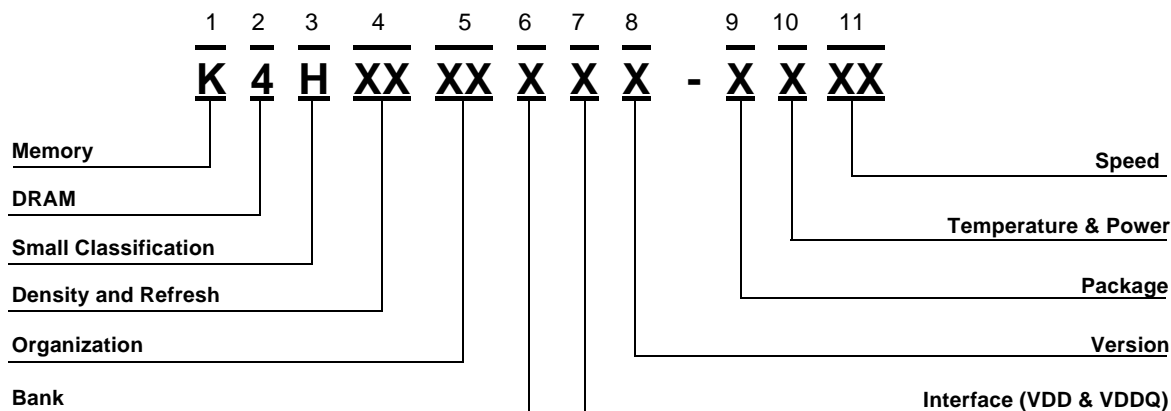

1. SAMSUNG Memory : K

2. DRAM : 4

3. Small Classification

H : DDR SDRAM

4. Density & Refresh

64 : 64M 4K/64ms
28 : 128M 4K/64ms
56 : 256M 8K/64ms
51 : 512M 8K/64ms
1G : 1G 16K/32ms

5. Organization

04 : x4
08 : x8
16 : x16
32 : x32

6. Bank

3 : 4 Bank

7. Interface (VDD & VDDQ)

8: SSTL-2(2.5V, 2.5V)

8. Version

M : 1st Generation
A : 2nd Generation
B : 3rd Generation
C : 4th Generation
D : 5th Generation
E : 6th Generation

9. Package

T : TSOP2 (400mil x 875mil)

10. Temperature & Power

C : (Commercial, Normal)
L : (Commercial, Low)

11. Speed

A0 : 10ns@CL2
A2 : 7.5ns@CL2
B0 : 7.5ns@CL2.5

128Mb DDR SDRAM

1. Key Features

1.1 Features

- Double-data-rate architecture; two data transfers per clock cycle
- Bidirectional data strobe(DQS)
- Four banks operation
- Differential clock inputs(CK and $\overline{\text{CK}}$)
- DLL aligns DQ and DQS transition with CK transition
- MRS cycle with address key programs
 - Read latency 2, 2.5 (clock)
 - Burst length (2, 4, 8)
 - Burst type (sequential & interleave)
- All inputs except data & DM are sampled at the positive going edge of the system clock(CK)
- Data I/O transactions on both edges of data strobe
- Edge aligned data output, center aligned data input
- LDM,UDM/DM for write masking only
- Auto & Self refresh
- 15.6 μ s refresh interval(4K/64ms refresh)
- Maximum burst refresh cycle : 8
- 66pin TSOP II package

1.2 Operating Frequencies

	- A2(DDR266A)	- B0(DDR266B)	- A0(DDR200)
Speed @CL2	133MHz@CL2	100MHz	100MHz
Speed @CL2.5	-	133MHz	-
DLL jitter	± 0.75 ns	± 0.75 ns	± 0.8 ns

*CL : Cas Latency

Table 1. Operating frequency and DLL jitter

128Mb DDR SDRAM

2.2 Input/Output Function Description

SYMBOL	TYPE	DESCRIPTION
CK, \overline{CK}	Input	Clock : CK and \overline{CK} are differential clock inputs. All address and control input signals are sampled on the positive edge of CK and negative edge of \overline{CK} . Output (read) data is referenced to both edges of CK. Internal clock signals are derived from CK/ \overline{CK} .
CKE	Input	Clock Enable : CKE HIGH activates, and CKE LOW deactivates internal clock signals, and device input buffers and output drivers. Deactivating the clock provides PRECHARGE POWER-DOWN and SELF REFRESH operation (all banks idle), or ACTIVE POWER-DOWN (row ACTIVE in any bank). CKE is synchronous for all functions except for disabling outputs, which is achieved asynchronously. Input buffers, excluding CK, \overline{CK} and CKE are disabled during power-down and self refresh modes, providing low standby power. CKE will recognize an LVCMOS LOW level prior to VREF being stable on power-up.
\overline{CS}	Input	Chip Select : \overline{CS} enables (registered LOW) and disables (registered HIGH) the command decoder. All commands are masked when \overline{CS} is registered HIGH. \overline{CS} provides for external bank selection on systems with multiple banks. \overline{CS} is considered part of the command code.
\overline{RAS} , \overline{CAS} , \overline{WE}	Input	Command Inputs : \overline{RAS} , \overline{CAS} and \overline{WE} (along with \overline{CS}) define the command being entered.
LDM,(U)DM	Input	Input Data Mask : DM is an input mask signal for write data. Input data is masked when DM is sampled HIGH along with that input data during a WRITE access. DM is sampled on both edges of DQS. DM pins include dummy loading internally, to matches the DQ and DQS loading. For the x16, LDM corresponds to the data on DQ0-DQ7 ; UDM corresponds to the data on DQ8-DQ15.
BA0, BA1	Input	Bank Address Inputs : BA0 and BA1 define to which bank an ACTIVE, READ, WRITE or PRECHARGE command is being applied.
A [n : 0]	Input	Address Inputs : Provide the row address for ACTIVE commands, and the column address and AUTO PRECHARGE bit for READ/WRITE commands, to select one location out of the memory array in the respective bank. A10 is sampled during a PRECHARGE command to determine whether the PRECHARGE applies to one bank (A10 LOW) or all banks (A10 HIGH). If only one bank is to be precharged, the bank is selected by BA0, BA1. The address inputs also provide the op-code during a MODE REGISTER SET command. BA0 and BA1 define which mode register is loaded during the MODE REGISTER SET command (MRS or EMRS).
DQ	I/O	Data Input/Output : Data bus
LDQS,(U)DQS	I/O	Data Strobe : Output with read data, input with write data. Edge-aligned with read data, centered in write data. Used to capture write data. For the x16, LDQS corresponds to the data on DQ0-DQ7 ; UDQS corresponds to the data on DQ8-DQ15.
\overline{QFC}	Output	FET Control : Optional. Output during every Read and Write access. Can be used to control isolation switches on modules.
NC	-	No Connect : No internal electrical connection is present.
V _{DDQ}	Supply	DQ Power Supply : +2.5V \pm 0.2V.
V _{SSQ}	Supply	DQ Ground.
V _{DD}	Supply	Power Supply : +2.5V \pm 0.2V (device specific).
V _{SS}	Supply	Ground.
VREF	Input	SSTL_2 reference voltage.

Table 3. Input/Output Function Description

128Mb DDR SDRAM

2.3 66 Pin TSOP(II)/MS-024FC Package Physical Dimension

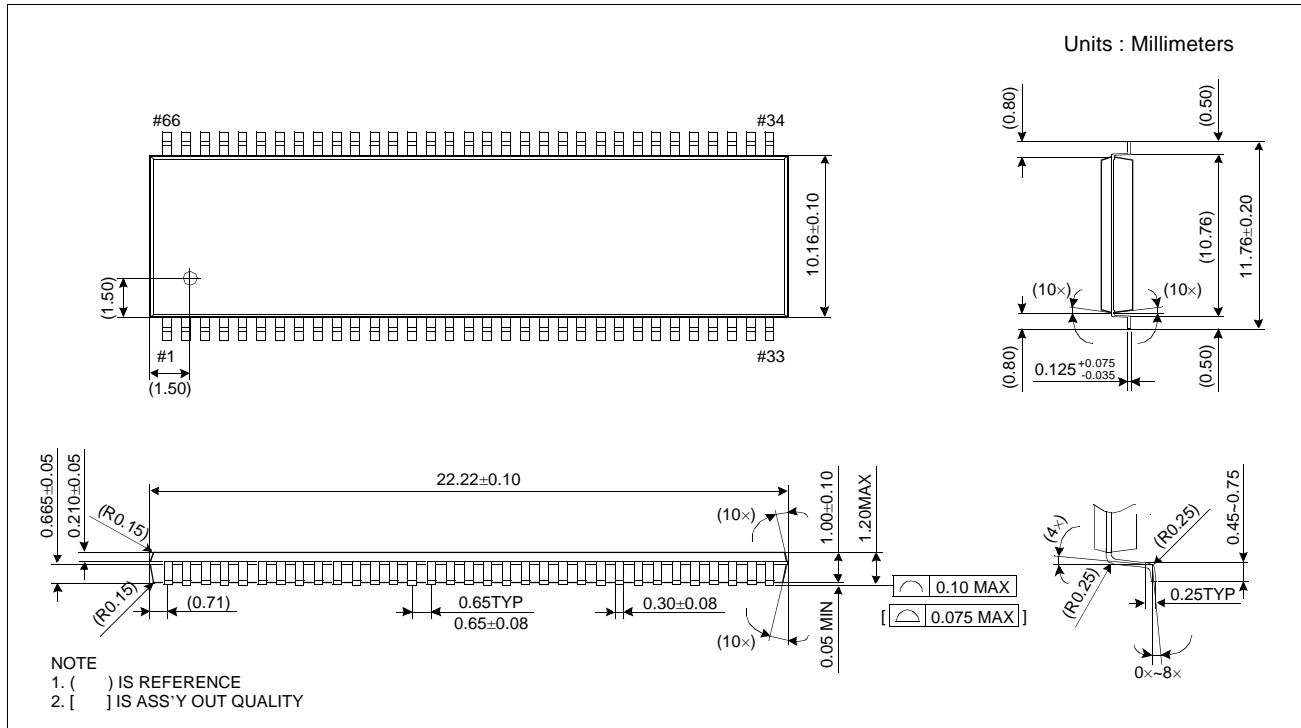

Figure 2. Package dimension

128Mb DDR SDRAM

3. Functional Description

3.1 Simplified State Diagram

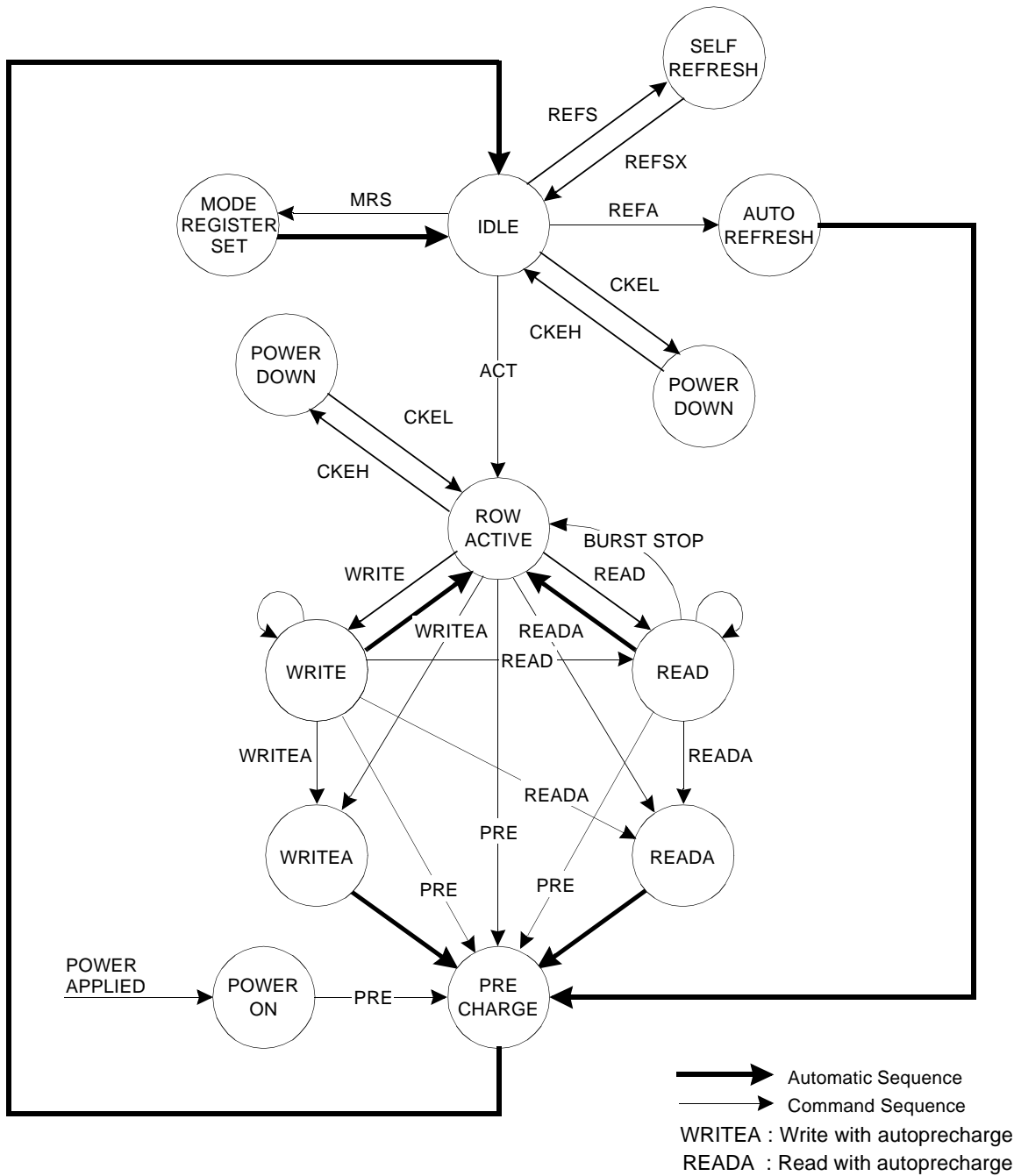

Figure 3. State diagram

128Mb DDR SDRAM

3.2 Basic Functionality

3.2.1 Power-Up and Initialization Sequence

The following sequence is required for POWER UP and Initialization.

1. Apply power and attempt to maintain CKE at a low state(all other inputs may be undefined.)
 - Apply VDD before or at the same time as VDDQ.
 - Apply VDDQ before or at the same time as VTT & Vref.
2. Start clock and maintain stable condition for a minimum of 200us.
3. The minimum of 200us after stable power and clock(CK, \overline{CK}), apply NOP & take CKE high.
4. Issue precharge commands for all banks of the device.
- *1 5. Issue EMRS to enable DLL.(To issue "DLL Enable" command, provide "Low" to A0, "High" to BA0 and "Low" to all of the rest address pins, A1~A11 and BA1)
- *1 6. Issue a mode register set command for "DLL reset". The additional 200 cycles of clock input is required to lock the DLL.
(To issue DLL reset command, provide "High" to A8 and "Low" to BA0)
- *2 7. Issue precharge commands for all banks of the device.
8. Issue 2 or more auto-refresh commands.
9. Issue a mode register set command with low to A8 to initialize device operation.

*1 Every "DLL enable" command resets DLL. Therefore sequence 6 can be skipped during power up.

Instead of it, the additional 200 cycles of clock input is required to lock the DLL after enabling DLL.

*2 Sequence of 6 & 7 is regardless of the order.

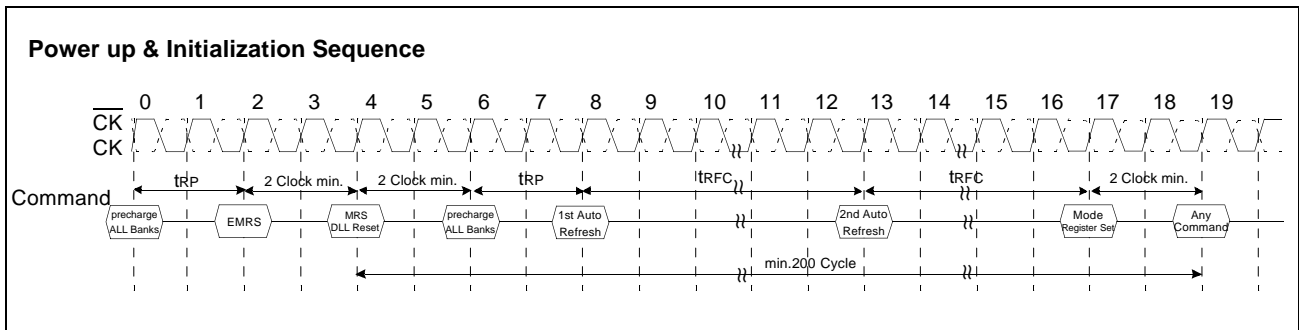

Figure 4. Power up and initialization sequence

128Mb DDR SDRAM

3.2.2 Mode Register Definition

3.2.2.1 Mode Register Set(MRS)

The mode register stores the data for controlling the various operating modes of DDR SDRAM. It programs CAS latency, addressing mode, burst length, test mode, DLL reset and various vendor specific options to make DDR SDRAM useful for variety of different applications. The default value of the mode register is not defined, therefore the mode register must be written after EMRS setting for proper DDR SDRAM operation. The mode register is written by asserting low on CS, RAS, CAS, WE and BA0(The DDR SDRAM should be in all bank pre-charge with CKE already high prior to writing into the mode register). The states of address pins A0 ~ A11 in the same cycle as CS, RAS, CAS, WE and BA0 going low are written in the mode register. Two clock cycles are requested to complete the write operation in the mode register. The mode register contents can be changed using the same command and clock cycle requirements during operation as long as all banks are in the idle state. The mode register is divided into various fields depending on functionality. The burst length uses A0 ~ A2, addressing mode uses A3, CAS latency(read latency from column address) uses A4 ~ A6. A7 is used for test mode. A8 is used for DLL reset. A7 must be set to low for normal MRS operation. Refer to the table for specific codes for various burst lengths, addressing modes and CAS latencies.

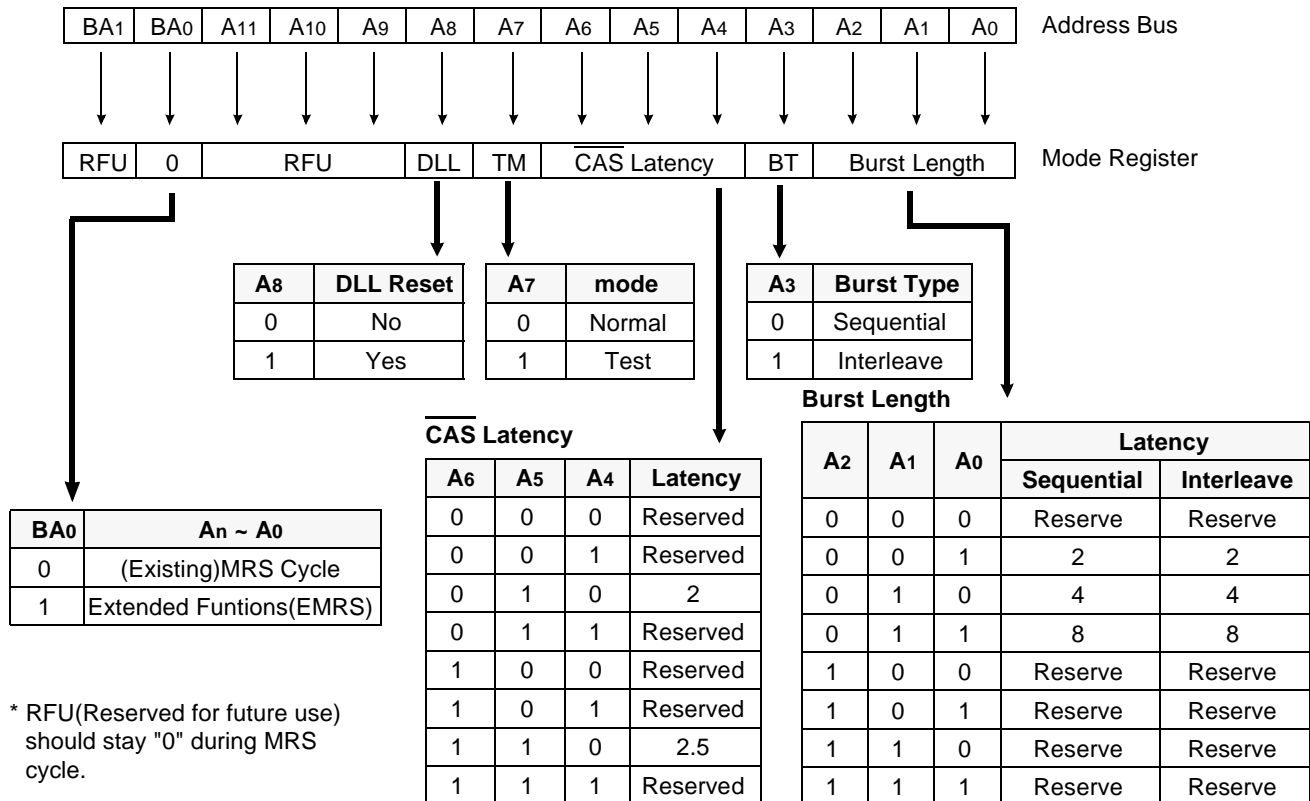

Figure 5. Mode Register Set

128Mb DDR SDRAM

Burst Address Ordering for Burst Length

Burst Length	Starting Address(A2, A1, A0)	Sequential Mode	Interleave Mode
2	xx0	0, 1	0, 1
	xx1	1, 0	1, 0
4	x00	0, 1, 2, 3	0, 1, 2, 3
	x01	1, 2, 3, 0	1, 0, 3, 2
	x10	2, 3, 0, 1	2, 3, 0, 1
	x11	3, 0, 1, 2	3, 2, 1, 0
8	000	0, 1, 2, 3, 4, 5, 6, 7	0, 1, 2, 3, 4, 5, 6, 7
	001	1, 2, 3, 4, 5, 6, 7, 0	1, 0, 3, 2, 5, 4, 7, 6
	010	2, 3, 4, 5, 6, 7, 0, 1	2, 3, 0, 1, 6, 7, 4, 5
	011	3, 4, 5, 6, 7, 0, 1, 2	3, 2, 1, 0, 7, 6, 5, 4
	100	4, 5, 6, 7, 0, 1, 2, 3	4, 5, 6, 7, 0, 1, 2, 3
	101	5, 6, 7, 0, 1, 2, 3, 4	5, 4, 7, 6, 1, 0, 3, 2
	110	6, 7, 0, 1, 2, 3, 4, 5	6, 7, 4, 5, 2, 3, 0, 1
	111	7, 0, 1, 2, 3, 4, 5, 6	7, 6, 5, 4, 3, 2, 1, 0

Table 4. Burst address ordering for burst length

DLL Enable/Disable

The DLL must be enabled for normal operation. DLL enable is required during power-up initialization, and upon returning to normal operation after having disabled the DLL for the purpose of debug or evaluation (upon exiting Self Refresh Mode, the DLL is enabled automatically). Any time the DLL is enabled, 200 clock cycles must occur before a READ command can be issued.

Output Drive Strength

The normal drive strength for all outputs is specified to be SSTL_2, Class II. Some vendors might also support a weak driver strength option, intended for lighter load and/or point-to-point environments. I-V curves for the normal drive strength and weak drive strength will be included in a future revision of this document.

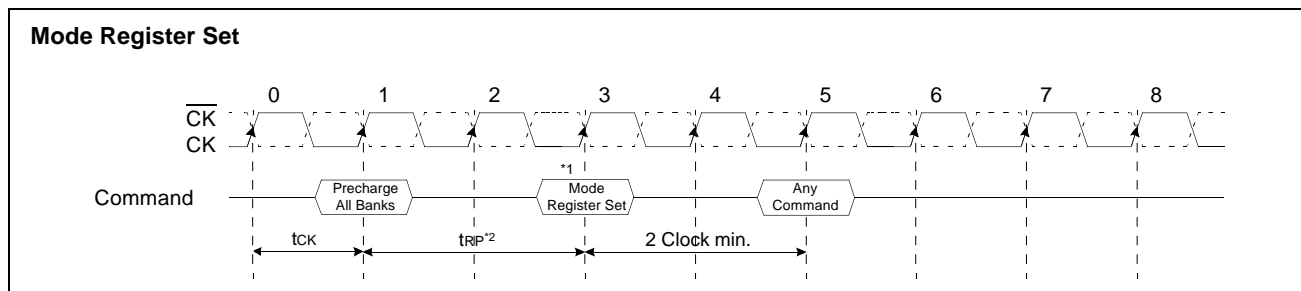

*1 : MRS can be issued only at all bank precharge state.

*2 : Minimum tRP is required to issue MRS command.

Figure 6. Mode Register Set sequence

128Mb DDR SDRAM

3.2.2.2 Extended Mode Register Set(EMRS)

The extended mode register stores the data for enabling or disabling DLL, \overline{QFC} and selecting output driver size. The default value of the extended mode register is not defined, therefore the extended mode register must be written after power up for enabling or disabling DLL. The extended mode register is written by asserting low on CS, RAS, CAS, WE and high on BA0(The DDR SDRAM should be in all bank precharge with CKE already high prior to writing into the extended mode register). The state of address pins A0 ~ A11 and BA1 in the same cycle as CS, RAS, CAS and WE going low are written in the extended mode register. Two clock cycles are required to complete the write operation in the extended mode register. The mode register contents can be changed using the same command and clock cycle requirements during operation as long as all banks are in the idle state. A0 is used for DLL enable or disable. "High" on BA0 is used for EMRS. All the other address pins except A0 and BA0 must be set to low for proper EMRS operation. Refer to the table for specific codes.

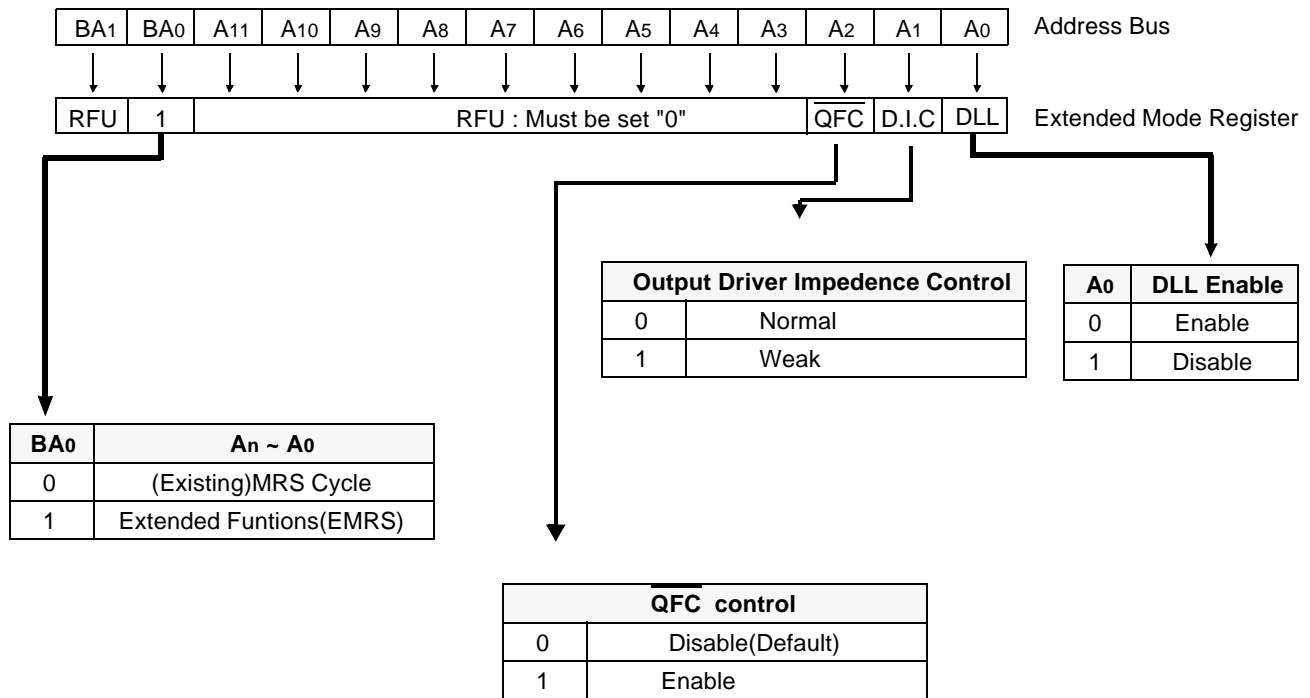

Figure 7. Extend Mode Register set

128Mb DDR SDRAM

3.2.3 Precharge

The precharge command is used to precharge or close a bank that has been activated. The precharge command is issued when \overline{CS} , \overline{RAS} and \overline{WE} are low and \overline{CAS} is high at the rising edge of the clock. The precharge command can be used to precharge each bank respectively or all banks simultaneously. The bank select addresses(BA0, BA1) are used to define which bank is precharged when the command is initiated. For write cycle, $tWR(\text{min.})$ must be satisfied until the precharge command can be issued. After tRP from the precharge, an active command to the same bank can be initiated.

Bank Selection for Precharge by Bank address bits

A10/AP	BA1	BA0	Precharge
0	0	0	Bank A Only
0	0	1	Bank B Only
0	1	0	Bank C Only
0	1	1	Bank D Only
1	X	X	All Banks

Table 5. Bank selection for precharge by Bank address bits

3.2.4 No Operation(NOP) & Device Deselect

The device should be deselected by deactivating the \overline{CS} signal. In this mode DDR SDRAM should ignore all the control inputs. The DDR SDRAMs are put in NOP mode when \overline{CS} is active and by deactivating \overline{RAS} , \overline{CAS} and \overline{WE} . For both Deselect and NOP the device should finish the current operation when this command is issued.

128Mb DDR SDRAM

3.2.5 Row Active

The Bank Activation command is issued by holding $\overline{\text{CAS}}$ and $\overline{\text{WE}}$ high with $\overline{\text{CS}}$ and $\overline{\text{RAS}}$ low at the rising edge of the clock (CK). The DDR SDRAM has four independent banks, so two Bank Select addresses (BA0, BA1) are required. The Bank Activation command must be applied before any Read or Write operation is executed. The delay from the Bank Activation command to the first read or write command must meet or exceed the minimum of RAS to CAS delay time (tRCD min). Once a bank has been activated, it must be precharged before another Bank Activation command can be applied to the same bank. The minimum time interval between interleaved Bank Activation commands (Bank A to Bank B and vice versa) is the Bank to Bank delay time (tRRD min).

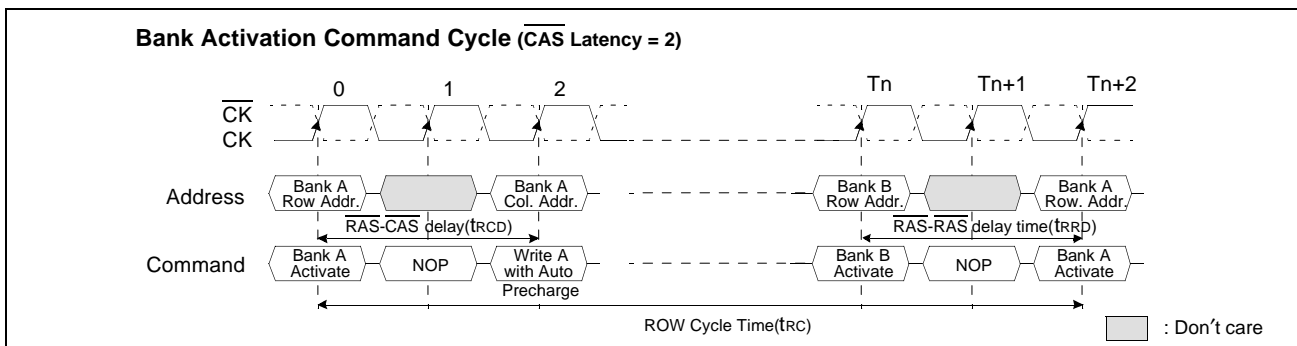

Figure 8. Bank activation command cycle timing

3.2.6 Read Bank

This command is used after the row activate command to initiate the burst read of data. The read command is initiated by activating RAS, $\overline{\text{CS}}$, $\overline{\text{CAS}}$, and deasserting $\overline{\text{WE}}$ at the same clock sampling (rising) edge as described in the command truth table. The length of the burst and the CAS latency time will be determined by the values programmed during the MRS command.

3.2.7 Write Bank

This command is used after the row activate command to initiate the burst write of data. The write command is initiated by activating RAS, $\overline{\text{CS}}$, $\overline{\text{CAS}}$, and $\overline{\text{WE}}$ at the same clock sampling (rising) edge as described in the command truth table. The length of the burst will be determined by the values programmed during the MRS command.

128Mb DDR SDRAM

3.3 Essential Functionality for DDR SDRAM

The essential functionality that is required for the DDR SDRAM device is described in this chapter

3.3.1 Burst Read Operation

Burst Read operation in DDR SDRAM is in the same manner as the current SDRAM such that the Burst read command is issued by asserting \overline{CS} and CAS low while holding RAS and WE high at the rising edge of the clock(CK) after tRCD from the bank activation. The address inputs (A0-A9) determine the starting address for the Burst. The Mode Register sets type of burst(Sequential or interleave) and burst length(2, 4, 8). The first output data is available after the CAS Latency from the READ command, and the consecutive data are presented on the falling and rising edge of Data Strobe(DQS) adopted by DDR SDRAM until the burst length is completed.

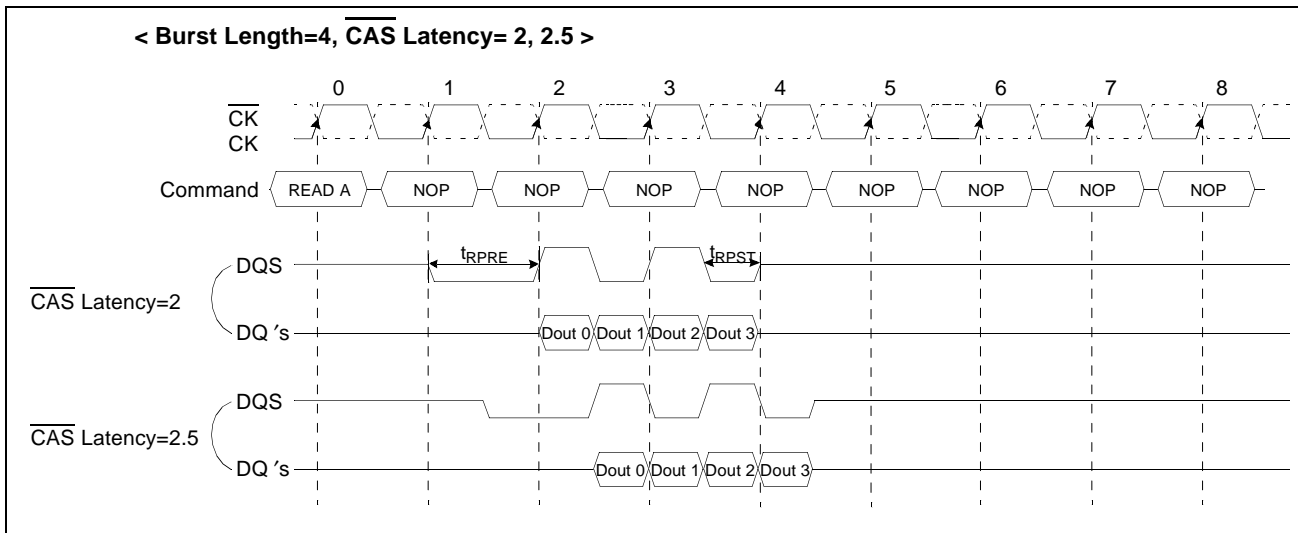

Figure 9. Burst read operation timing

128Mb DDR SDRAM

3.3.2 Burst Write Operation

The Burst Write command is issued by having \overline{CS} , \overline{CAS} , and \overline{WE} low while holding \overline{RAS} high at the rising edge of the clock(CK). The address inputs determine the starting column address. There is no write latency relative to DQS required for burst write cycle. The first data of a burst write cycle must be applied on the DQ pins t_{DS} (Data-in setup time) prior to data strobe edge enabled after t_{DQSS} from the rising edge of the clock(CK) that the write command is issued. The remaining data inputs must be supplied on each subsequent falling and rising edge of Data Strobe until the burst length is completed. When the burst has been finished, any additional data supplied to the DQ pins will be ignored.

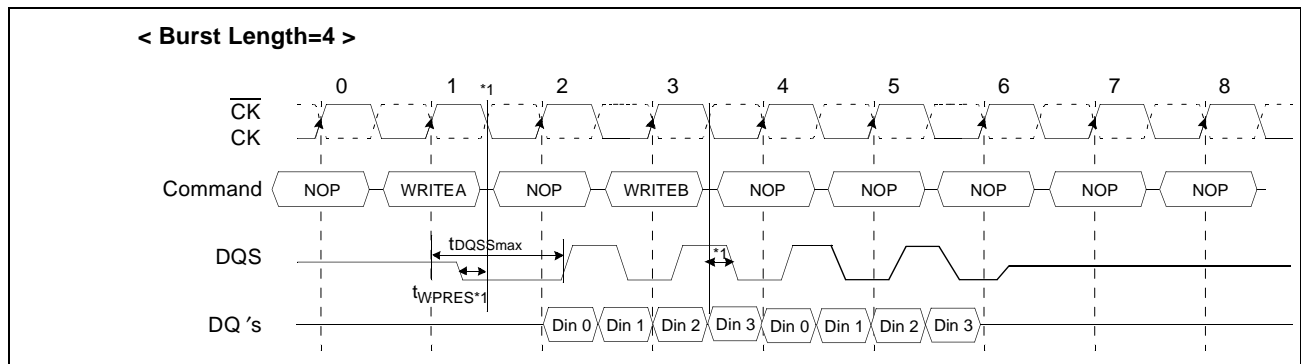

Figure 10. Burst write operation timing

1. The specific requirement is that DQS be valid(High or Low) on or before this CK edge. The case shown (DQS going from High_Z to logic Low) applies when no writes were previously in progress on the bus. If a previous write was in progress, DQS could be High at this time, depending on t_{DQSS} .

128Mb DDR SDRAM

3.3.3 Read Interrupted by a Read

A Burst Read can be interrupted before completion of the burst by new Read command of any bank. When the previous burst is interrupted, the remaining addresses are overridden by the new address with the full burst length. The data from the first Read command continues to appear on the outputs until the CAS latency from the interrupting Read command is satisfied. At this point the data from the interrupting Read command appears. Read to Read interval is minimum 1 Clock.

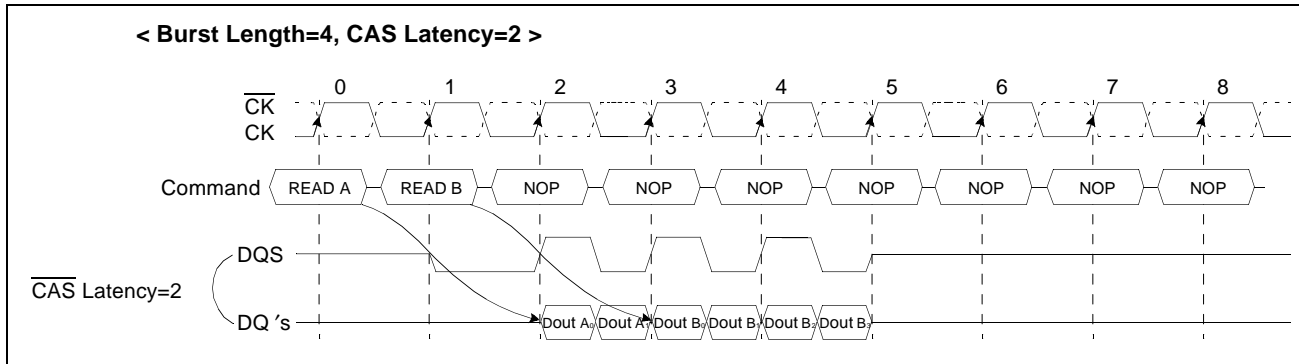

Figure 11. Read interrupted by a read timing

3.3.4 Read Interrupted by a Write & Burst Stop

To interrupt a burst read with a write command, Burst Stop command must be asserted to avoid data contention on the I/O bus by placing the DQ's (Output drivers) in a high impedance state. To insure the DQ's are tri-stated one cycle before the beginning the write operation, Burst stop command must be applied at least 2 clock cycles for CL=2 and at least 3 clock cycles for CL=2.5 before the Write command.

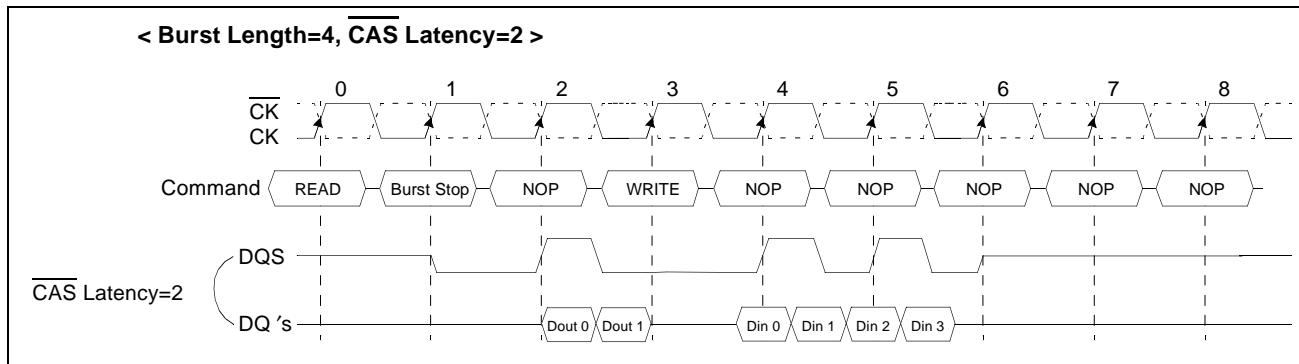

Figure 12. Read interrupted by a write and burst stop timing.

The following functionality establishes how a Write command may interrupt a Read burst.

1. For Write commands interrupting a Read burst, a Burst Terminate command is required to stop the read burst and tristate the DQ bus prior to valid input write data. Once the Burst Terminate command has been issued, the minimum delay to a Write command = $RU(CL)$ [CL is the CAS Latency and RU means round up to the nearest integer].
2. It is illegal for a Write command to interrupt a Read with autoprecharge command.

128Mb DDR SDRAM

3.3.5 Read Interrupted by a Precharge

A Burst Read operation can be interrupted by precharge of the same bank. The minimum 1 clock is required for the read to precharge intervals. A precharge command to output disable latency is equivalent to the CAS latency.

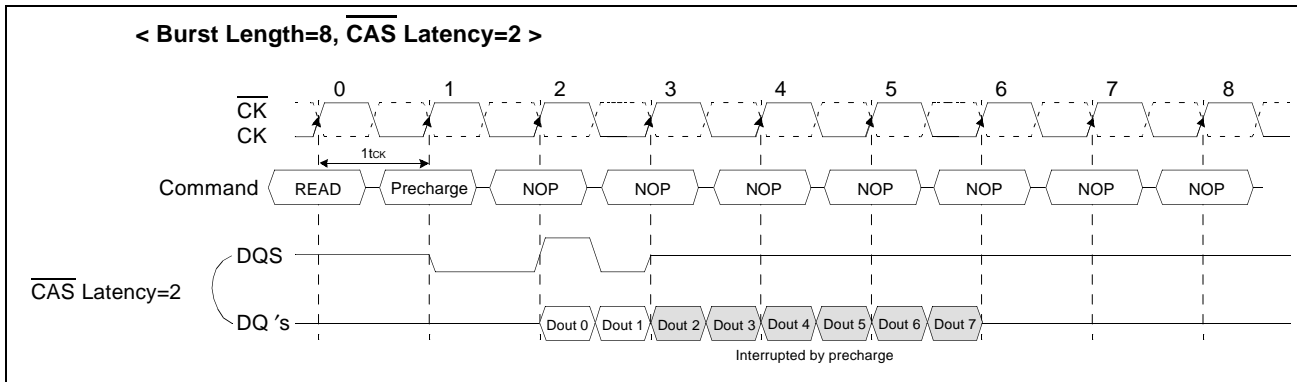

Figure 13. Read interrupted by a precharge timing

When a burst Read command is issued to a DDR SDRAM, a Precharge command may be issued to the same bank before the Read burst is complete. The following functionality determines when a Precharge command may be given during a Read burst and when a new Bank Activate command may be issued to the same bank.

1. For the earliest possible Precharge command without interrupting a Read burst, the Precharge command may be given on the rising clock edge which is CL clock cycles before the end of the Read burst where CL is the CAS Latency. A new Bank Activate command may be issued to the same bank after tRP (RAS Precharge time).
2. When a Precharge command interrupts a Read burst operation, the Precharge command may be given on the rising clock edge which is CL clock cycles before the last data from the interrupted Read burst where CL is the CAS Latency. Once the last data word has been output, the output buffers are tristated. A new Bank Activate command may be issued to the same bank after tRP.
3. For a Read with autoprecharge command, a new Bank Activate command may be issued to the same bank after tRP where tRP begins on the rising clock edge which is CL clock cycles before the end of the Read burst where CL is the CAS Latency. During Read with autoprecharge, the initiation of the internal precharge occurs at the same time as the earliest possible external Precharge command would initiate a precharge operation without interrupting the Read burst as described in 1 above.
4. For all cases above, tRP is an analog delay that needs to be converted into clock cycles. The number of clock cycles between a Precharge command and a new Bank Activate command to the same bank equals tRP/tCK (where tCK is the clock cycle time) with the result rounded up to the nearest integer number of clock cycles. (Note that rounding to X.5 is not possible since the Precharge and Bank Activate commands can only be given on a rising clock edge).

In all cases, a Precharge operation cannot be initiated unless tRAS(min) [minimum Bank Activate to Precharge time] has been satisfied. This includes Read with autoprecharge commands where tRAS(min) must still be satisfied such that a Read with autoprecharge command has the same timing as a Read command followed by the earliest possible Precharge command which does not interrupt the burst.

128Mb DDR SDRAM

3.3.6 Write Interrupted by a Write

A Burst Write can be interrupted before completion of the burst by a new Write command, with the only restriction that the interval that separates the commands must be at least one clock cycle. When the previous burst is interrupted, the remaining addresses are overridden by the new address and data will be written into the device until the programmed burst length is satisfied.

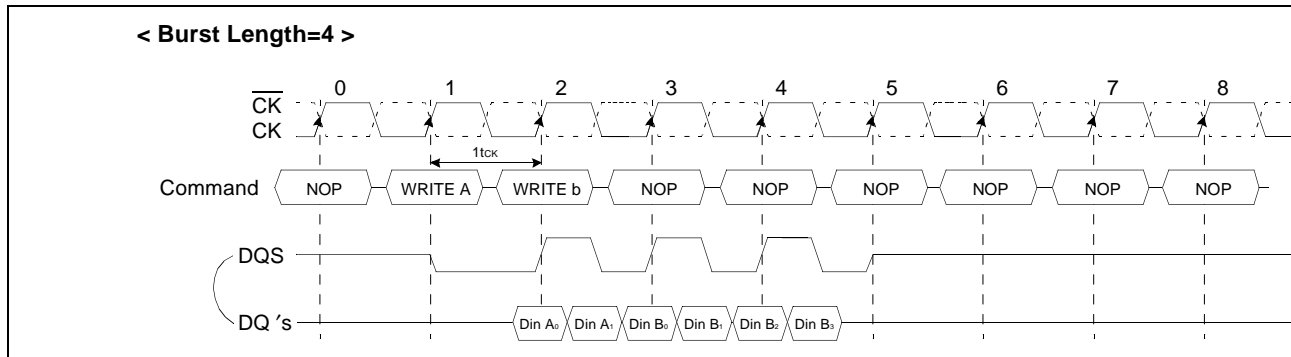

Figure 14. Write interrupted by a write timing

128Mb DDR SDRAM

3.3.7 Write Interrupted by a Read & DM

A burst write can be interrupted by a read command of any bank. The DQ's must be in the high impedance state at least one clock cycle before the interrupting read data appear on the outputs to avoid data contention. When the read command is registered, any residual data from the burst write cycle must be masked by DM. The delay from the last data to read command (t_{CDLR}) is required to avoid the data contention DRAM inside. Data that are presented on the DQ pins before the read command is initiated will actually be written to the memory. Read command interrupting write can not be issued at the next clock edge of that of write command.

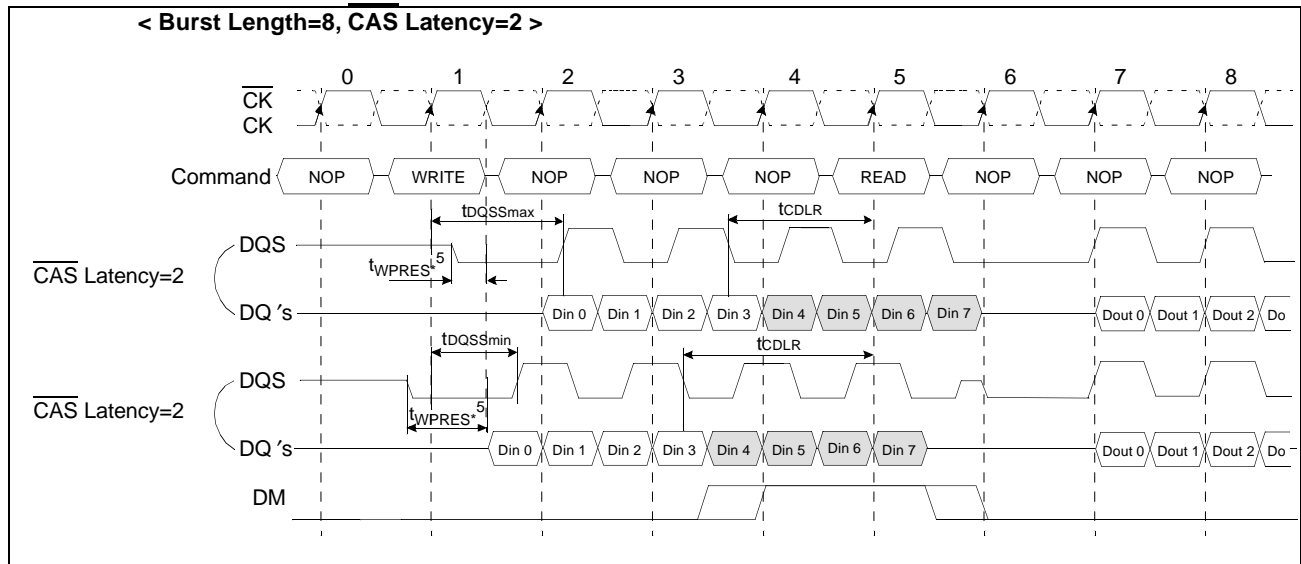

Figure 15. Write interrupted by a read and DM timing

The following function established how a Read command may interrupt a Write burst and which input data is not written into the memory.

1. For Read commands interrupting a Write burst, the minimum Write to Read command delay is 2 clock cycles. The case where the Write to Read delay is 1 clock cycle is disallowed
2. For Read commands interrupting a Write burst, the DM pin must be used to mask the input data words which immediately precede the interrupting Read operation and the input data word which immediately follows the interrupting Read operation
3. For all cases of a Read interrupting a Write, the DQ and DQS buses must be released by the driving chip (i.e., the memory controller) in time to allow the buses to turn around before the DDR SDRAM drives them during a read operation.
4. If input Write data is masked by the Read command, the DQS input is ignored by the DDR SDRAM.
5. Refer to "3.3.2 Burst write operation"

128Mb DDR SDRAM

3.3.8 Write Interrupted by a Precharge & DM

A burst write operation can be interrupted before completion of the burst by a precharge of the same bank. Random column access is allowed. A write recovery time (t_{WR}) is required from the last data to precharge command. When precharge command is asserted, any residual data from the burst write cycle must be masked by DM.

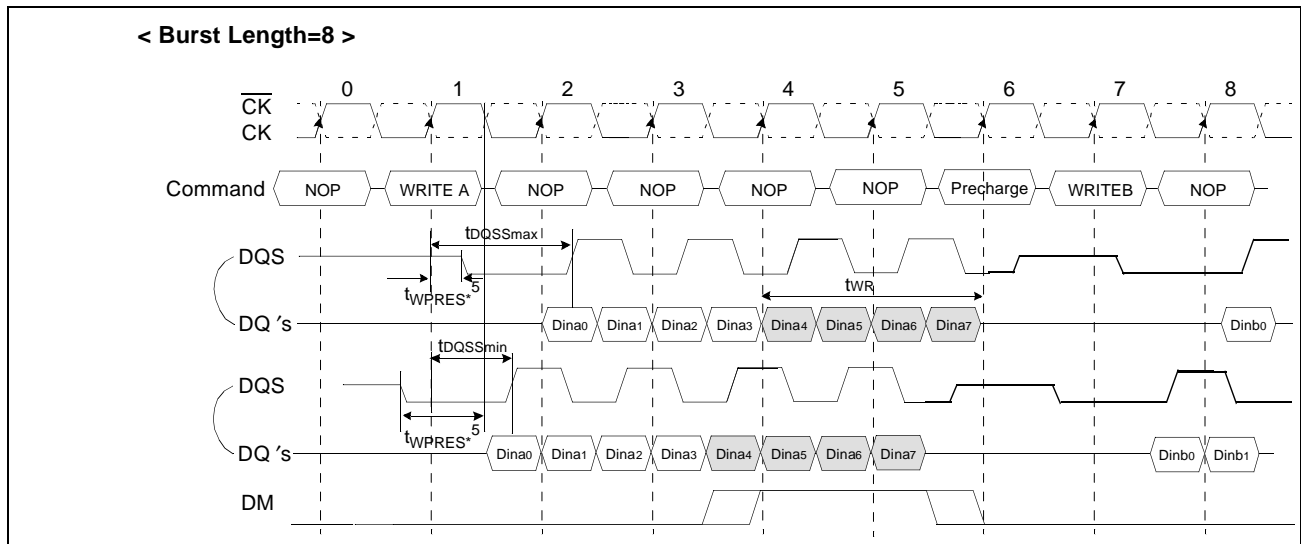

Figure 16. Write interrupted by a precharge and DM timing

Precharge timing for Write operations in DRAMs requires enough time to allow "write recovery" which is the time required by a DRAM core to properly store a full '0' or '1' level before a Precharge operation. For DDR SDRAM, a timing parameter, t_{WR} , is used to indicate the required amount of time between the last valid write operation and a Precharge command to the same bank.

The precharge timing for writes is a complex definition since the write data is sampled by the data strobe and the address is sampled by the input clock. Inside the SDRAM, the data path is eventually synchronized with the address path by switching clock domains from the data strobe clock domain to the input clock domain. This makes the definition of when a precharge operation can be initiated after a write very complex since the write recovery parameter must reference only the clock domain that is used to time the internal write operation, i.e., the input clock domain.

t_{WR} starts on the rising clock edge after the last possible DQS edge that strobed in the last valid data and ends on the rising clock edge that strobes in the precharge command.

1. For the earliest possible Precharge command following a Write burst without interrupting the burst, the minimum time for write recovery is defined by t_{WR} .
2. When a precharge command interrupts a Write burst operation, the data mask pin, DM, is used to mask input data during the time between the last valid write data and the rising clock edge on which the Precharge command is given. During this time, the DQS input is still required to strobe in the state of DM. The minimum time for write recovery is defined by t_{WR} .

128Mb DDR SDRAM

3. For a Write with autoprecharge command, a new Bank Activate command may be issued to the same bank after $t_{WR}+t_{RP}$ where $t_{WR}+t_{RP}$ starts on the falling DQS edge that strobed in the last valid data and ends on the rising clock edge that strobes in the Bank Activate command. During write with autoprecharge, the initiation of the internal precharge occurs at the same time as the earliest possible external Precharge command without interrupting the Write burst as described in 1 above.
4. In all cases, a Precharge operation cannot be initiated unless $t_{RAS}(\text{min})$ [minimum Bank Activate to Precharge time] has been satisfied. This includes Write with autoprecharge commands where $t_{RAS}(\text{min})$ must still be satisfied such that a Write with autoprecharge command has the same timing as a Write command followed by the earliest possible Precharge command which does not interrupt the burst.
5. Refer to "3.3.2 Burst write operation"

3.3.9 Burst Stop

The burst stop command is initiated by having \overline{RAS} and \overline{CAS} high with \overline{CS} and \overline{WE} low at the rising edge of the clock(CK). The burst stop command has the fewest restrictions making it the easiest method to use when terminating a burst read operation before it has been completed. When the burst stop command is issued during a burst read cycle, the pair of data and DQS(Data Strobe) go to a high impedance state after a delay which is equal to the CAS latency set in the mode register. The burst stop command, however, is not supported during a write burst operation.

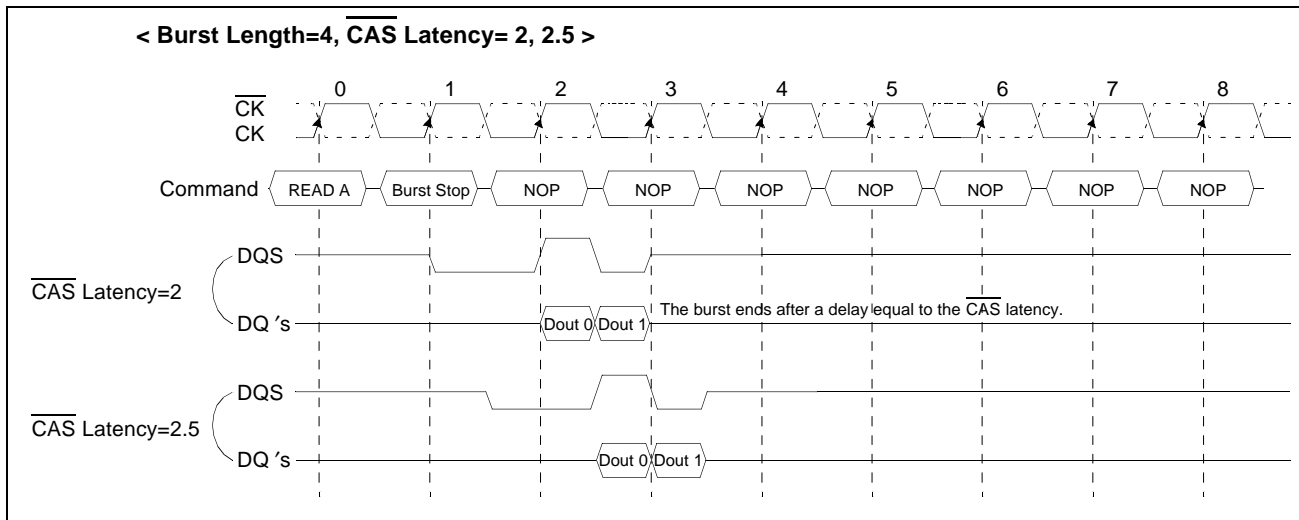

Figure 17. Burst stop timing

The Burst Stop command is a mandatory feature for DDR SDRAMs. The following functionality is required:

1. The BST command may only be issued on the rising edge of the input clock, CK.
2. BST is only a valid command during Read bursts.
3. BST during a Write burst is undefined and shall not be used.
4. BST applies to all burst lengths.
5. BST is an undefined command during Read with autoprecharge and shall not be used.

128Mb DDR SDRAM

6. When terminating a burst Read command, the BST command must be issued L_{BST} ('BST Latency') clock cycles before the clock edge at which the output buffers are tristated, where L_{BST} equals the \overline{CAS} latency for read operations. This is shown in previous page Figure with examples for CAS latency (CL) of 1.5, 2, 2.5, 3 and 3.5 (only selected CAS latencies are required by the DDR SDRAM standards, the others are optional).
7. When the burst terminates, the DQ and DQS pins are tristated.

The BST command is not byte controllable and applies to all bits in the DQ data word and the(all) DQS pin(s).

3.3.10 DM masking

The DDR SDRAM has a data mask function that can be used in conjunction with data write cycle, not read cycle. When the data mask is activated (DM high) during write operation, DDR SDRAM does not accept the corresponding data. (DM to data-mask latency is zero). DM must be issued at the rising or falling edge of data strobe.

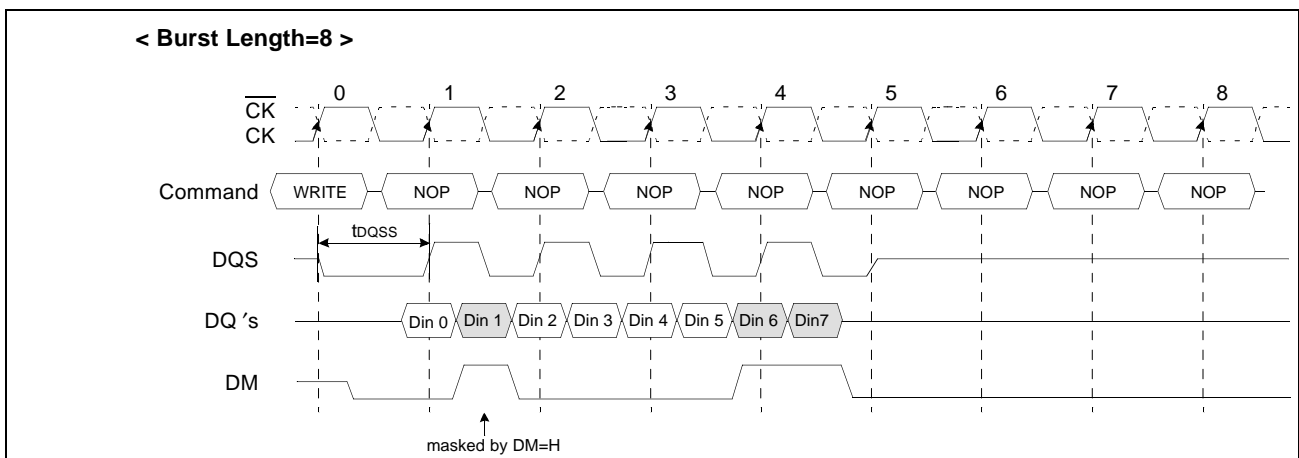

Figure 18. DM masking timing

128Mb DDR SDRAM

3.3.11 Read With Auto Precharge

If a read with auto-precharge command is initiated, the DDR SDRAM automatically enters the precharge operation BL/2 clock later from a read with auto-precharge command when tRAS(min) is satisfied. If not, the start point of precharge operation will be delayed until tRAS(min) is satisfied. Once the precharge operation has started the bank cannot be reactivated and the new command can not be asserted until the precharge time(tRP) has been satisfied.

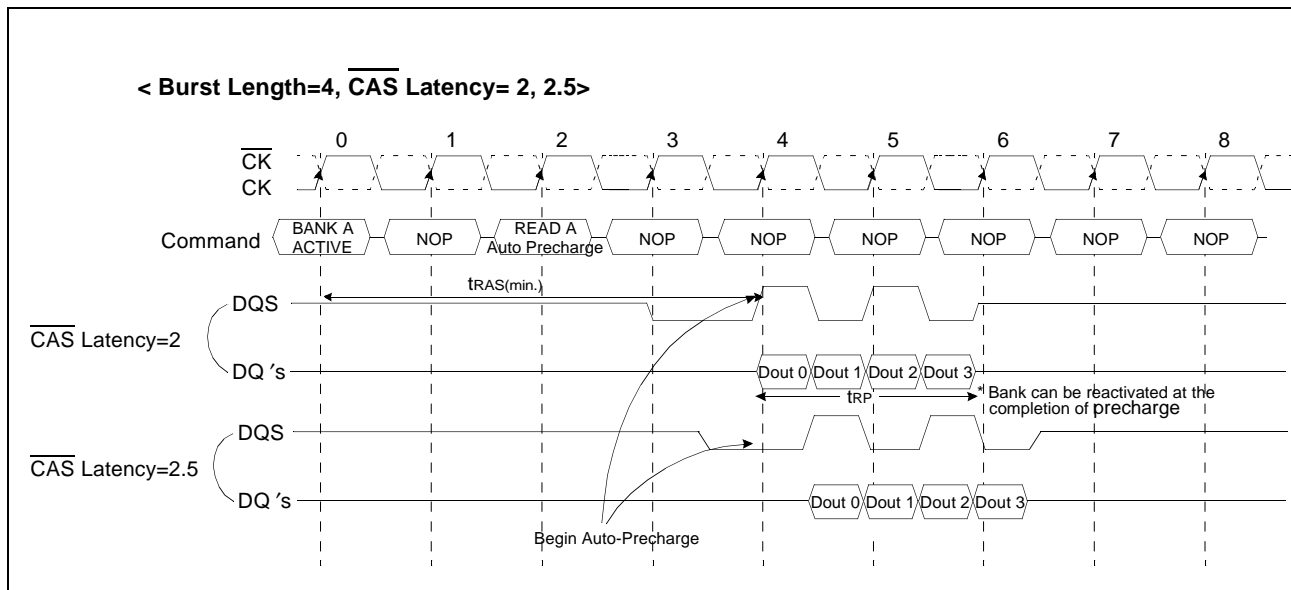

Figure 19. Read with auto precharge timing

When the Read with Auto precharge command is issued, new command can be asserted at 3,4 and 5 respectively as follows,

Asserted command	For same Bank			For Different Bank		
	3	4	5	3	4	5
READ	READ + No AP ^{*1}	READ+ No AP	Illegal	Legal	Legal	Legal
READ+AP	READ + AP	READ + AP	Illegal	Legal	Legal	Legal
Active	Illegal	Illegal	Illegal	Legal	Legal	Legal
Precharge	Legal	Legal	Illegal	Legal	Legal	Legal

^{*1} : AP = Auto Precharge

Table 6. Operating description when new command asserted while read with auto precharge is issued

128Mb DDR SDRAM

3.3.12 Write with Auto Precharge

If A10 is high when write command is issued, the write with auto-precharge function is performed. Any new command to the same bank should not be issued until the internal precharge is completed. The internal precharge begins after keeping $t_{WR}(\text{min})$.

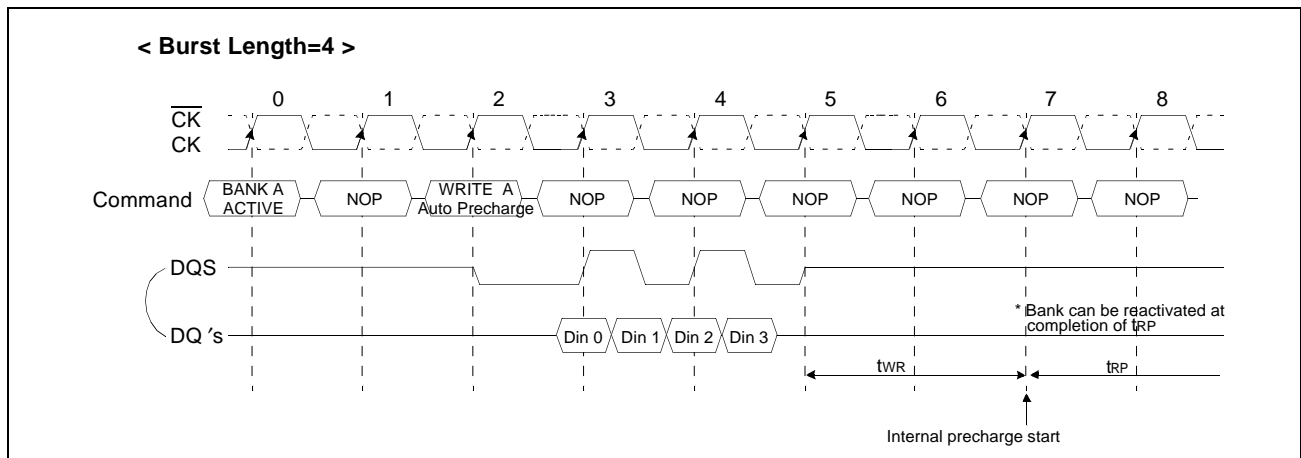

Figure 20. Write with auto precharge timing

Burst length = 4

Asserted command	For same Bank						For Different Bank				
	3	4	5	6	7	8	3	4	5	6	7
WRITE	WRITE+ No AP*1	WRITE+ No AP	WRITE+ No AP	Illegal	Illegal	Illegal	Legal	Legal	Legal	Legal	Legal
WRITE+ AP	WRITE+ AP	WRITE+ AP	WRITE+ AP	Illegal	Illegal	Illegal	Legal	Legal	Legal	Legal	Legal
READ	Illegal	READ+NO AP+DM*2	READ+NO AP+DM	READ+ NO AP	READ+ NO AP	Illegal	Illegal	Illegal	Legal	Legal	Legal
READ+AP	Illegal	READ + AP+DM	READ + AP+DM	READ + AP	READ + AP	Illegal	Illegal	Illegal	Legal	Legal	Legal
Active	Illegal	Illegal	Illegal	Illegal	Illegal	Illegal	Legal	Legal	Legal	Legal	Legal
Precharge	Illegal	Illegal	Illegal	Illegal	Illegal	Illegal	Legal	Legal	Legal	Legal	Legal

*1 : AP = Auto Precharge

*2 : DM : Refer to " 3.3.7 Write Interrupted by a Read & DM " in page 25.

Table 7. Operating description when new command asserted while write with auto precharge is issued

128Mb DDR SDRAM

3.3.13 Auto Refresh & Self Refresh

Auto Refresh

An auto refresh command is issued by having \overline{CS} , \overline{RAS} and \overline{CAS} held low with \overline{CKE} and \overline{WE} high at the rising edge of the clock(CK). All banks must be precharged and idle for $t_{RP}(\text{min})$ before the auto refresh command is applied. No control of the external address pins is required once this cycle has started because of the internal address counter. When the refresh cycle has completed, all banks will be in the idle state. A delay between the auto refresh command and the next activate command or subsequent auto refresh command must be greater than or equal to the $t_{RFC}(\text{min})$.

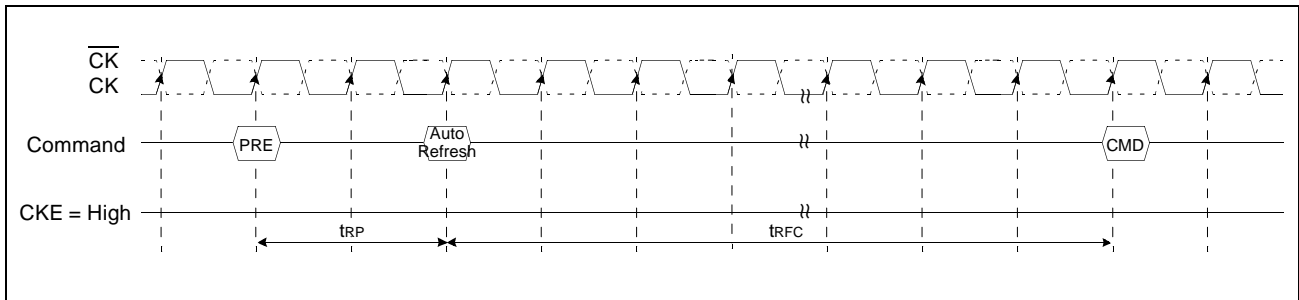

Figure 21. Auto refresh timing

Self Refresh

A self refresh command is defined by having \overline{CS} , \overline{RAS} , \overline{CAS} and \overline{CKE} held low with \overline{WE} high at the rising edge of the clock(CK). Once the self refresh command is initiated, \overline{CKE} must be held low to keep the device in self refresh mode. During the self refresh operation, all inputs except \overline{CKE} are ignored. The clock is internally disabled during self refresh operation to reduce power consumption. The self refresh is exited by supplying stable clock input before returning \overline{CKE} high, asserting deselect or NOP command and then asserting \overline{CKE} high for longer than t_{XSR} for locking of DLL.

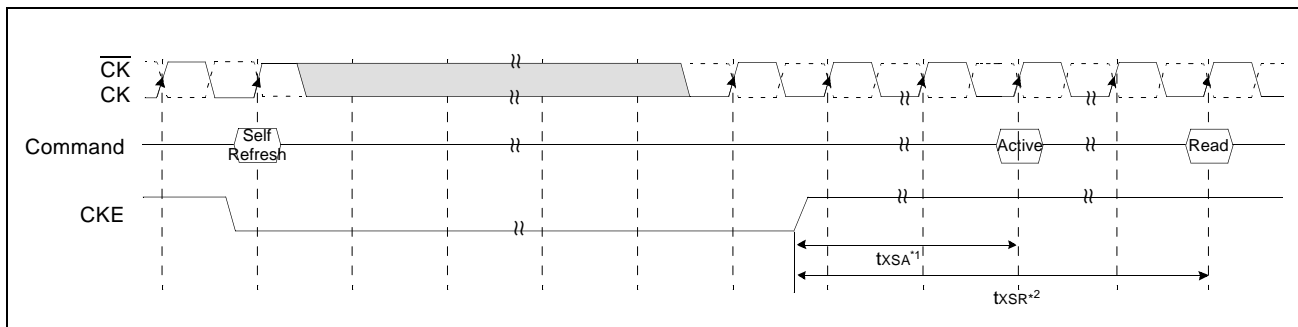

Figure 22. Self refresh timing

1. Exit self refresh to bank active command, a write command can be applied as far as t_{RCD} is satisfied after any bank active command.
2. Exit self refresh to read command

128Mb DDR SDRAM

3.3.14 Power down

The power down mode is entered when CKE is low and exited when CKE is high. Once the power down mode is initiated, all of the receiver circuits except clock, CKE and DLL circuit tree are gated off to reduce power consumption. All banks should be in idle state prior to entering the precharge power down mode and CKE should be set high at least $1t_{CK}+t_{IS}$ prior to row active command. During power down mode, refresh operations cannot be performed, therefore the device cannot be remained in power down mode longer than the refresh period(Data retention time) of the device.

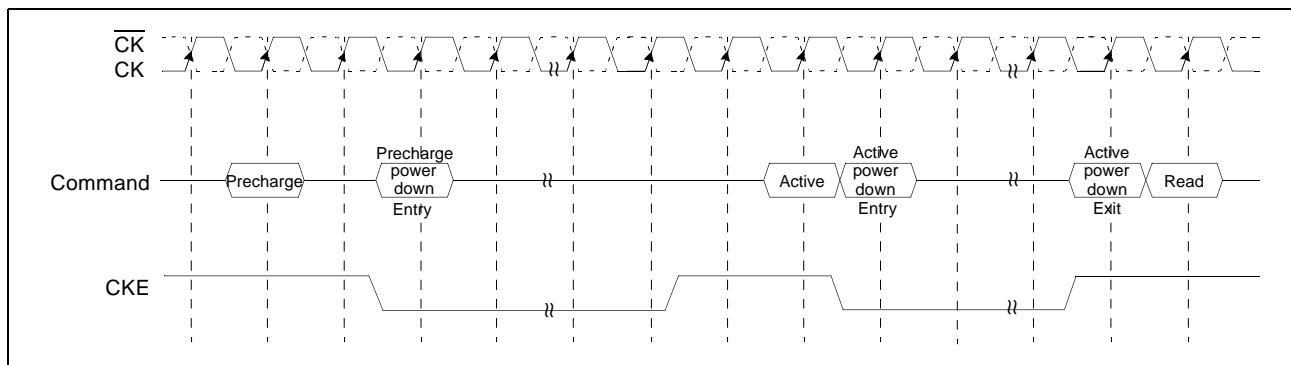

Figure 23. Power down entry and exit timing

128Mb DDR SDRAM

4. Command Truth Table

COMMAND		CKEn-1	CKEn	\overline{CS}	\overline{RAS}	\overline{CAS}	\overline{WE}	BA0,1	A10/AP	A11, A9 ~ A0	Note	
Register	Extended MRS	H	X	L	L	L	L	OP CODE			1, 2	
Register	Mode Register Set	H	X	L	L	L	L	OP CODE			1, 2	
Refresh	Auto Refresh		H	H	L	L	L	H	X		3	
	Self Refresh	Entry		L							3	
		Exit	L	H	L	H	H	H	X		3	
	H		X	X	X	3						
Bank Active & Row Addr.		H	X	L	L	H	H	V	Row Address			
Read & Column Address	Auto Precharge Disable		H	X	L	H	L	H	V	L	Column Address (A0~A9)	4
	Auto Precharge Enable								H	4		
Write & Column Address	Auto Precharge Disable		H	X	L	H	L	L	V	L	Column Address (A0~A9)	4
	Auto Precharge Enable								H	4, 6		
Burst Stop		H	X	L	H	H	L	X			7	
Precharge	Bank Selection		H	X	L	L	H	L	V	L	X	
	All Banks								X	H		5
Active Power Down	Entry		H	L	H	X	X	X	X			
	Exit				L	H	X	X			X	X
Precharge Power Down Mode	Entry		H	L	H	X	X	X	X			
					L	H	H	H				
	Exit		L	H	H	X	X	X				
					L	V	V	V				
DM		H	X					X			8	
No operation (NOP) : Not defined		H	X	H	X	X	X	X			9	
				L	H	H	H			9		

(V=Valid, X=Don't Care, H=Logic High, L=Logic Low)

Table 8. Command truth table

- OP Code : Operand Code. A0 ~ A11 & BA0 ~ BA1 : Program keys. (@EMRS/MRS)
- EMRS/ MRS can be issued only at all banks precharge state.
A new command can be issued 2 clock cycles after EMRS or MRS.
- Auto refresh functions are same as the CBR refresh of DRAM.
The automatical precharge without row precharge command is meant by "Auto".
Auto/self refresh can be issued only at all banks precharge state.
- BA0 ~ BA1 : Bank select addresses.
If both BA0 and BA1 are "Low" at read, write, row active and precharge, bank A is selected.
If both BA0 is "High" and BA1 is "Low" at read, write, row active and precharge, bank B is selected.
If both BA0 is "Low" and BA1 is "High" at read, write, row active and precharge, bank C is selected.
If both BA0 and BA1 are "High" at read, write, row active and precharge, bank D is selected.
- If A10/AP is "High" at row precharge, BA0 and BA1 are ignored and all banks are selected.
- During burst write with auto precharge, new read/write command can not be issued.
Another bank read/write command can be issued after the end of burst.
New row active of the associated bank can be issued at tRP after the end of burst.
- Burst stop command is valid at every burst length.
- DM sampled at the rising and falling edges of the DQS and Data-in are masked at the both edges (Write DM latency is 0).
- This combination is not defined for any function, which means "No Operation(NOP)" in DDR SDRAM.

128Mb DDR SDRAM

5. Functional Truth Table

Current State	\overline{CS}	\overline{RAS}	\overline{CAS}	\overline{WE}	Address	Command	Action
PRECHARGE STANDBY	L	H	H	L	X	Burst Stop	ILLEGAL*2
	L	H	L	X	BA, CA, A10	READ/WRITE	ILLEGAL*2
	L	L	H	H	BA, RA	Active	Bank Active, Latch RA
	L	L	H	L	BA, A10	PRE/PREA	ILLEGAL*4
	L	L	L	H	X	Refresh	AUTO-Refresh*5
	L	L	L	L	Op-Code, Mode-Add	MRS	Mode Register Set*5
ACTIVE STANDBY	L	H	H	L	X	Burst Stop	NOP
	L	H	L	H	BA, CA, A10	READ/READA	Begin Read, Latch CA, Determine Auto-Precharge
	L	H	L	L	BA, CA, A10	WRITE/WRITEA	Begin Write, Latch CA, Determine Auto-Precharge
	L	L	H	H	BA, RA	Active	Bank Active/ILLEGAL*2
	L	L	H	L	BA, A10	PRE/PREA	Precharge/Precharge All
	L	L	L	H	X	Refresh	ILLEGAL
	L	L	L	L	Op-Code, Mode-Add	MRS	ILLEGAL
READ	L	H	H	L	X	Burst Stop	Terminate Burst
	L	H	L	H	BA, CA, A10	READ/READA	Terminate Burst, Latch CA, Begin New Read, Determine Auto-Precharge*3
	L	H	L	L	BA, CA, A10	WRITE/WRITEA	ILLEGAL
	L	L	H	H	BA, RA	Active	Bank Active/ILLEGAL*2
	L	L	H	L	BA, A10	PRE/PREA	Terminate Burst, Precharge
	L	L	L	H	X	Refresh	ILLEGAL
	L	L	L	L	Op-Code, Mode-Add	MRS	ILLEGAL

Table 9-1. Functional truth table

128Mb DDR SDRAM

Current State	$\overline{\text{CS}}$	$\overline{\text{RAS}}$	$\overline{\text{CAS}}$	$\overline{\text{WE}}$	Address	Command	Action
WRITE	L	H	H	L	X	Burst Stop	ILLEGAL
	L	H	L	H	BA, CA, A10	READ/READA	Terminate Burst With DM=High, Latch CA, Begin Read, Determine Auto-Precharge*3
	L	H	L	L	BA, CA, A10	WRITE/WRITEA	Terminate Burst, Latch CA, Begin new Write, Determine Auto-Precharge*3
	L	L	H	H	BA, RA	Active	Bank Active/ILLEGAL*2
	L	L	H	L	BA, A10	PRE/PREA	Terminate Burst With DM=High, Precharge
	L	L	L	H	X	Refresh	ILLEGAL
	L	L	L	L	Op-Code, Mode-Add	MRS	ILLEGAL
READ with AUTO PRECHARGE*6 (READA)	L	H	H	L	X	Burst Stop	ILLEGAL
	L	H	L	H	BA, CA, A10	READ/READA	*6
	L	H	L	L	BA, CA, A10	WRITE/WRITEA	ILLEGAL
	L	L	H	H	BA, RA	Active	*6
	L	L	H	L	BA, A10	PRE/PREA	*6
	L	L	L	H	X	Refresh	ILLEGAL
	L	L	L	L	Op-Code, Mode-Add	MRS	ILLEGAL
WRITE with AUTO RECHARGE*7 (WRITEA)	L	H	H	L	X	Burst Stop	ILLEGAL
	L	H	L	H	BA, CA, A10	READ/READA	*7
	L	H	L	L	BA, CA, A10	WRITE/WRITEA	*7
	L	L	H	H	BA, RA	Active	*7
	L	L	H	L	BA, A10	PRE/PREA	*7
	L	L	L	H	X	Refresh	ILLEGAL
	L	L	L	L	Op-Code, Mode-Add	MRS	ILLEGAL

Table 9-2. Functional truth table

128Mb DDR SDRAM

Current State	$\overline{\text{CS}}$	$\overline{\text{RAS}}$	$\overline{\text{CAS}}$	$\overline{\text{WE}}$	Address	Command	Action
PRECHARGING (DURING tRP)	L	H	H	L	X	Burst Stop	ILLEGAL*2
	L	H	L	X	BA, CA, A10	READ/WRITE	ILLEGAL*2
	L	L	H	H	BA, RA	Active	ILLEGAL*2
	L	L	H	L	BA, A10	PRE/PREA	NOP*4(Idle after tRP)
	L	L	L	H	X	Refresh	ILLEGAL
	L	L	L	L	Op-Code, Mode-Add	MRS	ILLEGAL
ROW ACTIVATING (FROM ROW ACTIVE TO tRCD)	L	H	H	L	X	Burst Stop	ILLEGAL*2
	L	H	L	X	BA, CA, A10	READ/WRITE	ILLEGAL*2
	L	L	H	H	BA, RA	Active	ILLEGAL*2
	L	L	H	L	BA, A10	PRE/PREA	ILLEGAL*2
	L	L	L	H	X	Refresh	ILLEGAL
	L	L	L	L	Op-Code, Mode-Add	MRS	ILLEGAL
WRITE RECOVERING (DURING tWR OR tCDLR)	L	H	H	L	X	Burst Stop	ILLEGAL*2
	L	H	L	H	BA, CA, A10	READ	ILLEGAL*2
	L	H	L	L	BA, CA, A10	WRITE	WRITE
	L	L	H	H	BA, RA	Active	ILLEGAL*2
	L	L	H	L	BA, A10	PRE/PREA	ILLEGAL*2
	L	L	L	H	X	Refresh	ILLEGAL
	L	L	L	L	Op-Code, Mode-Add	MRS	ILLEGAL

Table 9-3. Functional truth table

128Mb DDR SDRAM

Current State	$\overline{\text{CS}}$	$\overline{\text{RAS}}$	$\overline{\text{CAS}}$	$\overline{\text{WE}}$	Address	Command	Action
RE-FRESHING	L	H	H	L	X	Burst Stop	ILLEGAL
	L	H	L	X	BA, CA, A10	READ/WRITE	ILLEGAL
	L	L	H	H	BA, RA	Active	ILLEGAL
	L	L	H	L	BA, A10	PRE/PREA	ILLEGAL
	L	L	L	H	X	Refresh	ILLEGAL
	L	L	L	L	Op-Code, Mode-Add	MRS	ILLEGAL
MODE REGISTER SETTING	L	H	H	L	X	Burst Stop	ILLEGAL
	L	H	L	X	BA, CA, A10	READ/WRITE	ILLEGAL
	L	L	H	H	BA, RA	Active	ILLEGAL
	L	L	H	L	BA, A10	PRE/PREA	ILLEGAL
	L	L	L	H	X	Refresh	ILLEGAL
	L	L	L	L	Op-Code, Mode-Add	MRS	ILLEGAL

Table 9-4. Functional truth table

128Mb DDR SDRAM

Current State	CKE _{n-1}	CKE _n	\overline{CS}	\overline{RAS}	\overline{CAS}	\overline{WE}	Add	Action
SELF-REFRESHING* ⁸	L	H	H	X	X	X	X	Exit Self-Refresh
	L	H	L	H	H	H	X	Exit Self-Refresh
	L	H	L	H	H	L	X	ILLEGAL
	L	H	L	H	L	X	X	ILLEGAL
	L	H	L	L	X	X	X	ILLEGAL
	L	L	X	X	X	X	X	NOPeration(Maintain Self-Refresh)
POWER DOWN	L	H	X	X	X	X	X	Exit Power Down(Idle after tPDEX)
	L	L	X	X	X	X	X	NOPeration(Maintain Power Down)
ALL BANKS IDLE* ⁹	H	H	X	X	X	X	X	Refer to Function True Table
	H	L	L	L	L	H	X	Enter Self-Refresh
	H	L	H	X	X	X	X	Enter Power Down
	H	L	L	H	H	H	X	Enter Power Down
	H	L	L	H	H	L	X	ILLEGAL
	H	L	L	H	L	X	X	ILLEGAL
	H	L	L	L	X	X	X	ILLEGAL
	L	X	X	X	X	X	X	Refer to Current State=Power Down
ANY STATE other than listed above	H	H	X	X	X	X	X	Refer to Function Truth Table

Table 9-5. Functional truth table

ABBREVIATIONS :

H=High Level, L=Low level, X=Don't Care

Note :

1. All entries assume that CKE was High during the preceding clock cycle and the current clock cycle.
2. ILLEGAL to bank in specified state ; function may be legal in the bank indicated by BA, depending on the state of that bank.
3. Must satisfy bus contention, bus turn around and write recovery requirements.
4. NOP to bank precharging or in idle state. May precharge bank indicated by BA.
5. ILLEGAL if any bank is not idle.
6. Refer to "3.3.11 Read with Auto Precharge" in page 29 for detailed information.
7. Refer to "3.3.12 Write with Auto Precharge" in page 30 for detailed information.
8. CKE Low to High transition will re-enable CK, \overline{CK} and other inputs asynchronously. A minimum setup time must be satisfied before issuing any command other than EXIT.
9. Power-Down and Self-Refresh can be entered only from All Bank Idle state.

ILLEGAL = Device operation and/or data integrity are not guaranteed.

128Mb DDR SDRAM

6. Absolute Maximum Rating

Parameter	Symbol	Value	Unit
Voltage on any pin relative to V_{SS}	V_{IN}, V_{OUT}	-0.5 ~ 3.6	V
Voltage on V_{DD} supply relative to V_{SS}	V_{DD}, V_{DDQ}	-1.0 ~ 3.6	V
Voltage on V_{DDQ} supply relative to V_{SS}	V_{DDQ}	-0.5 ~ 3.6	V
Storage temperature	T_{STG}	-55 ~ +150	°C
Power dissipation	P_D	1.0	W
Short circuit current	I_{OS}	50	mA

Note : Permanent device damage may occur if ABSOLUTE MAXIMUM RATINGS are exceeded.
 Functional operation should be restricted to recommend operation condition.
 Exposure to higher than recommended voltage for extended periods of time could affect device reliability

Table 10. Absolute maximum ratings

7. DC Operating Conditions & Specifications

7.1 DC Operating Conditions

Recommended operating conditions(Voltage referenced to $V_{SS}=0V$, $T_A=0$ to $70^{\circ}C$)

Parameter	Symbol	Min	Max	Unit	Note
Supply voltage(for device with a nominal V_{DD} of 2.5V)	V_{DD}	2.3	2.7		
I/O Supply voltage	V_{DDQ}	2.3	2.7	V	
I/O Reference voltage	V_{REF}	$0.49 \cdot V_{DDQ}$	$0.51 \cdot V_{DDQ}$	V	1
I/O Termination voltage(system)	V_{TT}	$V_{REF}-0.04$	$V_{REF}+0.04$	V	2
Input logic high voltage	$V_{IH}(DC)$	$V_{REF}+0.15$	$V_{DDQ}+0.3$	V	
Input logic low voltage	$V_{IL}(DC)$	-0.3	$V_{REF}-0.15$	V	
Input Voltage Level, CK and \overline{CK} inputs	$V_{IN}(DC)$	-0.3	$V_{DDQ}+0.3$	V	
Input Differential Voltage, CK and \overline{CK} inputs	$V_{ID}(DC)$	0.3	$V_{DDQ}+0.6$	V	3
Input leakage current	I_I	-2	2	uA	
Output leakage current	I_{OZ}	-5	5	uA	
Output High Current ($V_{OUT} = 1.95V$)	I_{OH}	-16.8		mA	
Output Low Current ($V_{OUT} = 0.35V$)	I_{OL}	16.8		mA	

- Notes 1. V_{REF} is expected to be equal to $0.5 \cdot V_{DDQ}$ of the transmitting device, and to track variations in the DC level of the same. Peak-to-peak noise on V_{REF} may not exceed 2% of the DC value
 2. V_{TT} is not applied directly to the device. V_{TT} is a system supply for signal termination resistors, is expected to be set equal to V_{REF} , and must track variations in the DC level of V_{REF}
 3. V_{ID} is the magnitude of the difference between the input level on CK and the input level on \overline{CK} .

Table 11. DC operating condition

128Mb DDR SDRAM

7.2 DDR SDRAM SPEC Items and Test Conditions

Conditions	Symbol	Typical	Worst
Operating current - One bank Active-Precharge; tRC=tRCmin;tCK=100Mhz for DDR200, 133Mhz for DDR266A & DDR266B; DQ,DM and DQS inputs changing twice per clock cycle; address and control inputs changing once per clock cycle	IDD0	-	-
Operating current - One bank operation ; One bank open, BL=4, Reads - Refer to the following page for detailed test condition	IDD1	-	-
Percharge power-down standby current; All banks idle; power - down mode; CKE = <VIL(max); tCK=100Mhz for DDR200, 133Mhz for DDR266A & DDR266B; Vin = Vref for DQ,DQS and DM	IDD2P	-	-
Precharge Floating standby current; CS# > =VIH(min);All banks idle; CKE > = VIH(min); tCK=100Mhz for DDR200, 133Mhz for DDR266A & DDR266B; Address and other control inputs changing once per clock cycle; Vin = Vref for DQ,DQS and DM	IDD2F	-	-
Precharge Quiet standby current; CS# > = VIH(min); All banks idle; CKE > = VIH(min); tCK = 100Mhz for DDR200, 133Mhz for DDR266A & DDR266B; Address and other control inputs stable with keeping >= VIH(min) or <=VIL(max); Vin = Vref for DQ ,DQS and DM	IDD2Q	-	-
Active power - down standby current ; one bank active; power-down mode; CKE=< VIL (max); tCK = 100Mhz for DDR200, 133Mhz for DDR266A & DDR266B; Vin = Vref for DQ,DQS and DM	IDD3P	-	-
Active standby current; CS# >= VIH(min); CKE>=VIH(min); one bank active; active - precharge; tRC=tRASmax; tCK = 100Mhz for DDR200, 133Mhz for DDR266A & DDR266B; DQ, DQS and DM inputs changing twice per clock cycle; address and other control inputs changing once per clock cycle	IDD3N	-	-
Operating current - burst read; Burst length = 2; reads; contiguous burst; One bank active; address and control inputs changing once per clock cycle; CL=2 at tCK = 100Mhz for DDR200, CL=2 at tCK = 133Mhz for DDR266A, CL=2.5 at tCK = 133Mhz for DDR266B ; 50% of data changing at every burst; Iout = 0 m A	IDD4R	-	-
Operating current - burst write; Burst length = 2; writes; continuous burst; One bank active address and control inputs changing once per clock cycle; CL=2 at tCK = 100Mhz for DDR200, CL=2 at tCK = 133Mhz for DDR266A, CL=2.5 at tCK = 133Mhz for DDR266B ; DQ, DM and DQS inputs changing twice per clock cycle, 50% of input data changing at every burst	IDD4W	-	-
Auto refresh current; tRC = tRFC(min) - 8*tCK for DDR200 at 100Mhz, 10*tCK for DDR266A & DDR266B at 133Mhz; distributed refresh	IDD5	-	-
Self refresh current; CKE =< 0.2V; External clock should be on; tCK = 100Mhz for DDR200, 133Mhz for DDR266A & DDR266B	IDD6	-	-
Operating current - Four bank operation ; Four bank interleaving with BL=4 -Refer to the following page for detailed test condition	IDD7	-	-

Typical case: VDD = 2.5V, T = 25C

Worst case : VDD = 2.7V, T = 10C

128Mb DDR SDRAM

7.3 DDR SDRAM I_{DD} spec table

32Mx4

Symbol	K4H280438B-TCA2 (DDR266A)		K4H280438B-TCB0 (DDR266B)		K4H280438B-TCA0 (DDR200)		Unit	Notes
	typical	worst	typical	worst	typical	worst		
IDD0	85	95	85	95	75	85	mA	
IDD1	125	140	125	140	120	130	mA	
IDD2P	21	25	21	25	18	22	mA	
IDD2F	40	45	40	45	35	40	mA	
IDD2Q	30	35	30	35	25	30	mA	
IDD3P	25	30	25	30	20	25	mA	
IDD3N	35	40	35	40	30	35	mA	
IDD4R	140	155	140	155	115	130	mA	
IDD4W	125	140	125	140	100	115	mA	
IDD5	185	200	185	200	175	190	mA	
IDD6	Normal	2	2	2	2	2	mA	
	Low power	1	1	1	1	1	mA	Optional
IDD7	250	265	250	265	240	255	mA	

16Mx8

Symbol	K4H280838BT-CA2 (DDR266A)		K4H280838B-TCB0 (DDR266B)		K4H280838B-TCA0 (DDR200)		Unit	Notes
	typical	worst	typical	worst	typical	worst		
IDD0	90	95	90	95	80	85	mA	
IDD1	140	150	140	150	125	135	mA	
IDD2P	21	25	21	25	19	23	mA	
IDD2F	40	45	40	45	35	40	mA	
IDD2Q	30	35	30	35	27	32	mA	
IDD3P	25	30	25	30	20	25	mA	
IDD3N	40	45	40	45	30	35	mA	
IDD4R	150	165	150	165	125	140	mA	
IDD4W	135	150	135	150	105	120	mA	
IDD5	195	205	195	205	180	190	mA	
IDD6	Normal	2	2	2	2	2	mA	
	Low power	1	1	1	1	1	mA	Optional
IDD7	260	280	260	280	250	275	mA	

128Mb DDR SDRAM

8Mx16

Symbol	K4H281638B-TCA2 (DDR266A)		K4H281638B-TCB0 (DDR266B)		K4H281638B-TCA0 (DDR200)		Unit	Notes
	typical	worst	typical	worst	typical	worst		
IDD0	90	95	90	95	80	85	mA	
IDD1	140	155	140	155	135	150	mA	
IDD2P	21	25	21	25	20	24	mA	
IDD2F	40	45	40	45	35	40	mA	
IDD2Q	30	35	30	35	27	32	mA	
IDD3P	25	30	25	30	20	25	mA	
IDD3N	45	50	45	50	35	40	mA	
IDD4R	210	245	210	245	155	175	mA	
IDD4W	150	165	150	165	110	125	mA	
IDD5	195	210	195	210	180	190	mA	
IDD6	Normal	2	2	2	2	2	mA	
	Low power	1	1	1	1	1	mA	Optional
IDD7	300	340	300	340	275	300	mA	

Table 12. 128Mb DDR SDRAM IDD SPEC Table

< Detailed test conditions for DDR SDRAM IDD1 & IDD7 >

IDD1 : Operating current: One bank operation

1. Typical Case : Vdd = 2.5V, T=25°C
2. Worst Case : Vdd = 2.7V, T= 10°C
3. Only one bank is accessed with tRC(min), Burst Mode, Address and Control inputs on NOP edge are changing once per clock cycle. Iout = 0mA
4. Timing patterns
 - DDR200(100Mhz, CL=2) : tCK = 10ns, CL2, BL=4, tRCD = 2*tCK, tRAS = 5*tCK
Read : A0 N R0 N N P0 N A0 N - repeat the same timing with random address changing
*50% of data changing at every burst
 - DDR266B(133Mhz, CL=2.5) : tCK = 7.5ns, CL=2.5, BL=4, tRCD = 3*tCK, tRC = 9*tCK, tRAS = 5*tCK
Read : A0 N N R0 N P0 N N A0 N - repeat the same timing with random address changing
*50% of data changing at every burst
 - DDR266A (133Mhz, CL=2) : tCK = 7.5ns, CL=2, BL=4, tRCD = 3*tCK, tRC = 9*tCK, tRAS = 5*tCK
Read : A0 N N R0 N P0 N N A0 N - repeat the same timing with random address changing
*50% of data changing at every burst

Legend : A=Activate, R=Read, W=Write, P=Precharge, N=NOP

128Mb DDR SDRAM

IDD7 : Operating current: Four bank operation

1. Typical Case : Vdd = 2.5V, T=25°C
2. Worst Case : Vdd = 2.7V, T= 10°C
3. Four banks are being interleaved with tRC(min), Burst Mode, Address and Control inputs on NOP edge are not changing. Iout = 0mA
4. Timing patterns
 - DDR200(100Mhz, CL=2) : tCK = 10ns, CL2, BL=4, tRRD = 2*tCK, tRCD= 3*tCK, Read with autoprecharge
Read : A0 N A1 R0 A2 R1 A3 R2 A0 R3 A1 R0 - repeat the same timing with random address changing
*50% of data changing at every burst
 - DDR266B(133Mhz, CL=2.5) : tCK = 7.5ns, CL=2.5, BL=4, tRRD = 2*tCK, tRCD = 3*tCK
Read with autoprecharge
Read : A0 N A1 R0 A2 R1 A3 R2 N R3 A0 N A1 R0 - repeat the same timing with random address changing
*50% of data changing at every burst
 - DDR266A (133Mhz, CL=2) : tCK = 7.5ns, CL=2, BL=4, tRRD = 2*tCK, tRCD = 3*tCK
Read : A0 N A1 R0 A2 R1 A3 R2 N R3 A0 N A1 R0 - repeat the same timing with random address changing
*50% of data changing at every burst

Legend : A=Activate, R=Read, W=Write, P=Precharge, N=NOP

8. AC Operating Conditions & Timming Specification

8.1 AC Operating Conditions

Parameter/Condition	Symbol	Min	Max	Unit	Note
Input High (Logic 1) Voltage, DQ, DQS and DM signals	V _{IH} (AC)	VREF + 0.31		V	1
Input Low (Logic 0) Voltage, DQ, DQS and DM signals.	V _{IL} (AC)		VREF - 0.31	V	2
Input Differential Voltage, CK and CK inputs	V _{ID} (AC)	0.62	VDDQ+0.6	V	3
Input Crossing Point Voltage, CK and CK inputs	V _{IX} (AC)	0.5*VDDQ-0.2	0.5*VDDQ+0.2	V	4

- Note 1. V_{IH}(max) = 4.2V. The overshoot voltage duration is ≤ 3ns at VDD.
 2. V_{IL}(min) = -1.5V. The undershoot voltage duration is ≤ 3ns at VSS.
 3. V_{ID} is the magnitude of the difference between the input level on CK and the input on \overline{CK} .
 4. The value of V_{IX} is expected to equal 0.5*V_{DDQ} of the transmitting device and must track variations in the DC level of the same.

Table 13. AC operating conditions

128Mb DDR SDRAM

8.2 AC Timing Parameters & Specifications

Parameter	Symbol	K4H281638B -TCA2 (DDR266A)		K4H281638B -TCB0 (DDR266B)		K4H281638B -TCA0 (DDR200)		Unit	Note	
		Min	Max	Min	Max	Min	Max			
Row cycle time	tRC	65		65		70		ns		
Refresh row cycle time	tRFC	75		75		80		ns		
Row active time	tRAS	45	120K	45	120K	48	120K	ns		
RAS to CAS delay	tRCD	20		20		20		ns		
Row precharge time	tRP	20		20		20		ns		
Row active to Row active delay	tRRD	15		15		15		ns		
Write recovery time	tWR	2		2		2		tCK		
Last data in to Read command	tCDLR	1		1		1		tCK		
Col. address to Col. address delay	tCCD	1		1		1		tCK		
Clock cycle time	CL=2.0	tCK	7.5	15	10	15	10	15	ns	
	CL=2.5			15	7.5	15		15	ns	
Clock high level width	tCH	0.45	0.55	0.45	0.55	0.45	0.55	tCK		
Clock low level width	tCL	0.45	0.55	0.45	0.55	0.45	0.55	tCK		
DQS-out access time from CK/CK	tDQSK	-0.75	+0.75	-0.75	+0.75	-0.8	+0.8	ns		
Output data access time from CK/CK	tAC	-0.75	+0.75	-0.75	+0.75	-0.8	+0.8	ns		
Data strobe edge to output data edge	tDQSQ	-	+0.5	-	+0.5	-	+0.6	ns		
Read Preamble	tRPRE	0.9	1.1	0.9	1.1	0.9	1.1	tCK		
Read Postamble	tRPST	0.4	0.6	0.4	0.6	0.4	0.6	tCK		
Data out high impedance time from CK/CK	tHZQ	-0.75	+0.75	-0.75	+0.75	-0.8	+0.8	ns	2	
CK to valid DQS-in	tDQSS	0.75	1.25	0.75	1.25	0.75	1.25	tCK		
DQS-in setup time	tWPRES	0		0		0		ns	3	
DQS-in hold time	tWPREH	0.25		0.25		0.25		tCK		
DQS-in high level width	tDQSH	0.4	0.6	0.4	0.6	0.4	0.6	tCK		
DQS-in low level width	tDQSL	0.4	0.6	0.4	0.6	0.4	0.6	tCK		
DQS-in cycle time	tDSC	0.9	1.1	0.9	1.1	0.9	1.1	tCK		
Address and Control Input setup time	tIS	0.9		0.9		1.1		ns		
Address and Control Input hold time	tIH	0.9		0.9		1.1		ns		
Mode register set cycle time	tMRD	15		15		16		ns		
DQ & DM setup time to DQS	tDS	0.5		0.5		0.6		ns		
DQ & DM hold time to DQS	tDH	0.5		0.5		0.6		ns		
DQ & DM input pulse width	tDIPW	1.75		1.75		2		ns		
Power down exit time	tPDEX	10		10		10		ns		
Exit self refresh to write command	tXSW	95				116		ns		

128Mb DDR SDRAM

Parameter	Symbol	-A2(PC266@CL=2)		-B0(PC266@CL=2.5)		-A0(PC200@CL=2)		Unit	Note	
		Min	Max	Min	Max	Min	Max			
Exit self refresh to bank active command	tXSA	75		75		80		ns	7	
Exit self refresh to read command	tXSR	200		200		200		Cycle		
Refresh interval time	64Mb, 128Mb	tREF	15.6		15.6		15.6		us	1
	256Mb		7.8		7.8		7.8		us	1
Output DQS valid window	tQH	tHPmin -0.75ns	-	tHPmin -0.75ns	-	tHPmin -1.0ns	-	ns		
Clock half period	tHP	tCLmin or tCHmin	-	tCLmin or tCHmin	-	tCLmin or tCHmin	-	ns		
DQS write postamble time	tWPST	0.25		0.25		0.25		tCK	4	
QFC setup to first DQS edge on reads	tQCS	0.9	1.1	0.9	1.1	0.9	1.1	tCK		
QFC hold after last DQS edge on reads	tQCH	0.4	0.6	0.4	0.6	0.4	0.6	tCK		
Write command to QFC delay on write	tQCSW		4.0		4.0		4.0	ns		
Write burst end to QFC delay on write	tQCHW	1.25ns	0.5tCK	1.25ns	0.5tCK	1.25ns	0.5tCK		5	
Write burst end to QFC delay on write interrupted by Precharge	tQCHWI	-	1.5tCK	-	1.5tCK	-	1.5tCK		6	

1. Maximum burst refresh of 8
2. tHZQ transitions occurs in the same access time windows as valid data transitions. These parameters are not referenced to a specific voltage level, but specify when the device output is no longer driving.
3. The specific requirement is that DQS be valid(High or Low) on or before this CK edge. The case shown(DQS going from High_Z to logic Low) applies when no writes were previously in progress on the bus. If a previous write was in progress, DQS could be High at this time, depending on tDQSS.
4. The maximum limit for this parameter is not a device limit. The device will operate with a great value for this parameter, but system performance (bus turnaround) will degrade accordingly.
5. The value of tQCSW min. is 1.25ns from the last low going data strobe edge to \overline{QFC} high. And the value of tQCSW max. is 0.5tCK from the first high going clock edge after the last low going data strobe edge to QFC high.
6. the value of tQCSWI max. is 1.5tCK from the first high going clock edge after the last low going data strobe edge to QFC high.
7. A write command can be applied with tRCD satisfied after this command.

Table 14. AC timing parameters and specifications

128Mb DDR SDRAM

9. AC Operating Test Conditions

(VDD=2.5V, VDDQ=2.5V, TA= 0 to 70°C)

Parameter	Value	Unit	Note
Input reference voltage for Clock	$0.5 * V_{DDQ}$	V	
Input signal maximum peak swing	1.5	V	
Input signal minimum slew rate	1.0	V/ns	
Input Levels(VIH/VIL)	$V_{REF}+0.31/V_{REF}-0.31$	V	
Input timing measurement reference level	V_{REF}	V	
Output timing measurement reference level	V_{tt}	V	
Output load condition	See Load Circuit		

Table 15. AC operating test conditions

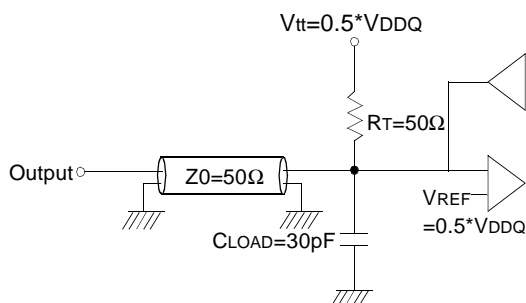

Figure 24. Output Load Circuit (SSTL_2)

10. Input/Output Capacitance

(VDD=2.5, VDDQ=2.5V, TA= 25°C, f=1MHz)

Parameter	Symbol	Min	Max	Delta Cap(max)	Unit
Input capacitance (A0 ~ A11, BA0 ~ BA1, \overline{CKE} , \overline{CS} , \overline{RAS} , \overline{CAS} , \overline{WE})	CIN1	2	3.0	0.5	pF
Input capacitance(CK, \overline{CK})	CIN2	2	3.0	0.25	pF
Data & DQS input/output capacitance	COUT	4.0	5.0	0.5	pF
Input capacitance(DM)	CIN3	4.0	5.0		pF

Table 16. Input/output capacitance

128Mb DDR SDRAM

11. IBIS: I/V Characteristics for Input and Output Buffers

11.1 Normal strength driver

1. The nominal pulldown V-I curve for DDR SDRAM devices will be within the inner bounding lines of the V-I curve of Figure a.
2. The full variation in driver pulldown current from minimum to maximum process, temperature and voltage will lie within the outer bounding lines of the V-I curve of Figure a.

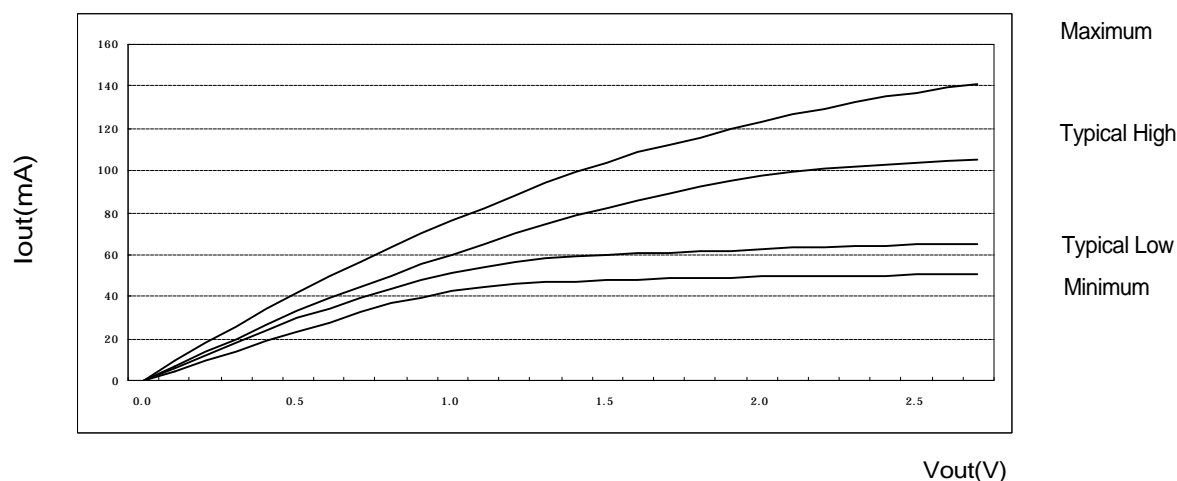

3. The nominal pullup V-I curve for DDR SDRAM devices will be within the inner bounding lines of the V-I curve of below Figure b.
4. The Full variation in driver pullup current from minimum to maximum process, temperature and voltage will lie within the outer bounding lines of the V-I curve of Figure b.

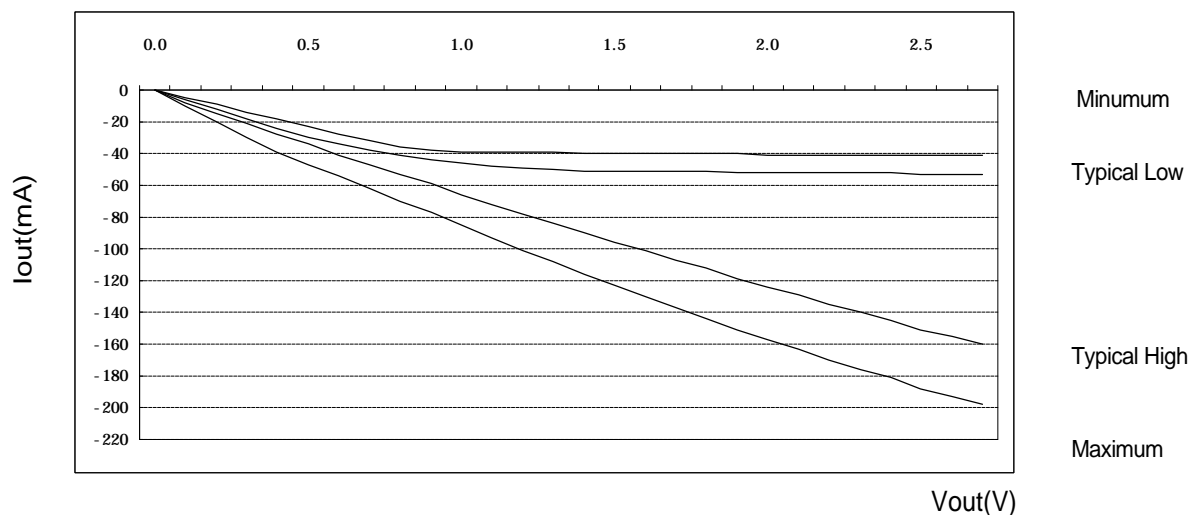

5. The full variation in the ratio of the maximum to minimum pullup and pulldown current will not exceed 1.7, for device drain to source voltage from 0 to $V_{DDQ}/2$
6. The Full variation in the ratio of the nominal pullup to pulldown current should be unity $\pm 10\%$, for device drain to source voltages from 0 to $V_{DDQ}/2$

Figure 25. I/V characteristics for input/output buffers: Pull up(above) and pull down(below)

128Mb DDR SDRAM

Voltage (V)	Pulldown Current (mA)				pullup Current (mA)			
	Typical Low	Typical High	Minimum	Maximum	Typical Low	Typical High	Minimum	Maximum
0.1	6.0	6.8	4.6	9.6	-6.1	-7.6	-4.6	-10.0
0.2	12.2	13.5	9.2	18.2	-12.2	-14.5	-9.2	-20.0
0.3	18.1	20.1	13.8	26.0	-18.1	-21.2	-13.8	-29.8
0.4	24.1	26.6	18.4	33.9	-24.0	-27.7	-18.4	-38.8
0.5	29.8	33.0	23.0	41.8	-29.8	-34.1	-23.0	-46.8
0.6	34.6	39.1	27.7	49.4	-34.3	-40.5	-27.7	-54.4
0.7	39.4	44.2	32.2	56.8	-38.1	-46.9	-32.2	-61.8
0.8	43.7	49.8	36.8	63.2	-41.1	-53.1	-36.0	-69.5
0.9	47.5	55.2	39.6	69.9	-41.8	-59.4	-38.2	-77.3
1.0	51.3	60.3	42.6	76.3	-46.0	-65.5	-38.7	-85.2
1.1	54.1	65.2	44.8	82.5	-47.8	-71.6	-39.0	-93.0
1.2	56.2	69.9	46.2	88.3	-49.2	-77.6	-39.2	-100.6
1.3	57.9	74.2	47.1	93.8	-50.0	-83.6	-39.4	-108.1
1.4	59.3	78.4	47.4	99.1	-50.5	-89.7	-39.6	-115.5
1.5	60.1	82.3	47.7	103.8	-50.7	-95.5	-39.9	-123.0
1.6	60.5	85.9	48.0	108.4	-51.0	-101.3	-40.1	-130.4
1.7	61.0	89.1	48.4	112.1	-51.1	-107.1	-40.2	-136.7
1.8	61.5	92.2	48.9	115.9	-51.3	-112.4	-40.3	-144.2
1.9	62.0	95.3	49.1	119.6	-51.5	-118.7	-40.4	-150.5
2.0	62.5	97.2	49.4	123.3	-51.6	-124.0	-40.5	-156.9
2.1	62.9	99.1	49.6	126.5	-51.8	-129.3	-40.6	-163.2
2.2	63.3	100.9	49.8	129.5	-52.0	-134.6	-40.7	-169.6
2.3	63.8	101.9	49.9	132.4	-52.2	-139.9	-40.8	-176.0
2.4	64.1	102.8	50.0	135.0	-52.3	-145.2	-40.9	-181.3
2.5	64.6	103.8	50.2	137.3	-52.5	-150.5	-41.0	-187.6
2.6	64.8	104.6	50.4	139.2	-52.7	-155.3	-41.1	-192.9
2.7	65.0	105.4	50.5	140.8	-52.8	-160.1	-41.2	-198.2

Table 17. Pull down and pull up current values

Temperature (Tambient)

Typical 25°C
 Minimum 70°C
 Maximum 0°C

Vdd/Vddq

Typical 2.5V
 Minimum 2.3V
 Maximum 2.7V

The above characteristics are specified under best, worst and normal process variation/conditions

128Mb DDR SDRAM

11.2 Half strength driver

1. The nominal pulldown V-I curve for DDR SDRAM devices will be within the inner bounding lines of the V-I curve of Figure a.
2. The full variation in driver pulldown current from minimum to maximum process, temperature and voltage will lie within the outer bounding lines the of the V-I curve of Figure a.

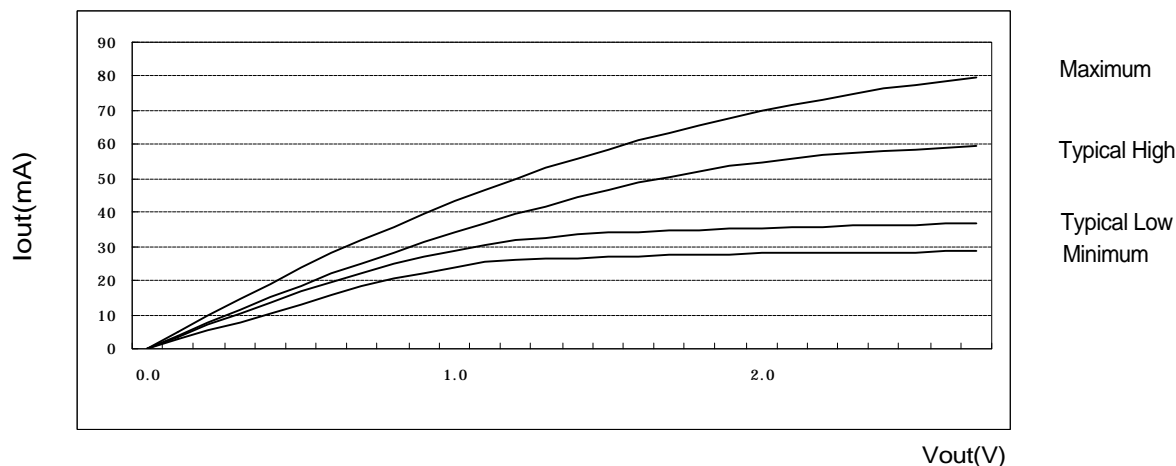

3. The nominal pullup V-I curve for DDR SDRAM devices will be within the inner bounding lines of the V-I curve of below Figure b.
4. The Full variation in driver pullup current from minimum to maximum process, temperature and voltage will lie within the outer bounding lines of the V-I curve of Figure b.

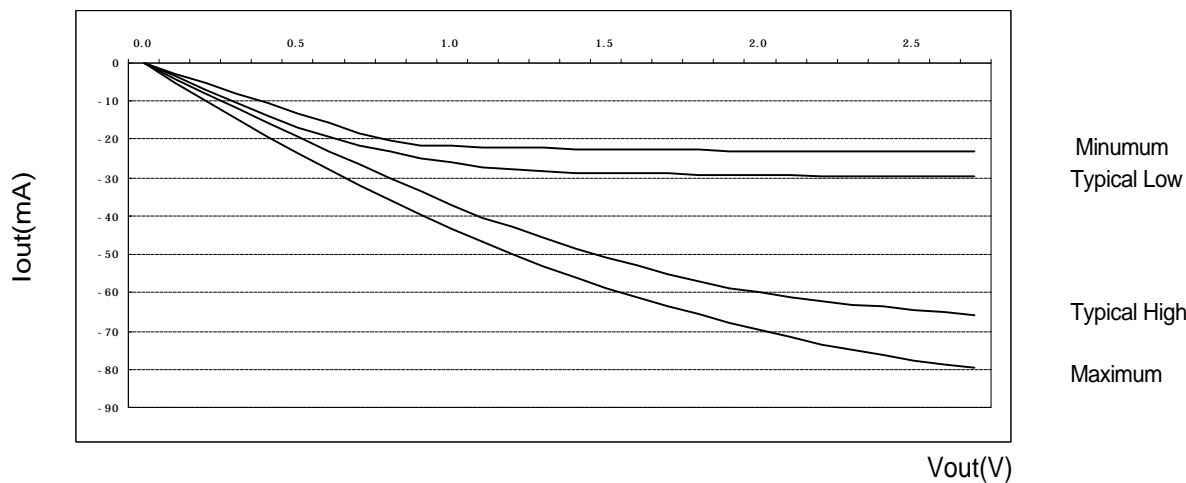

5. The full variation in the ratio of the maximum to minimum pullup and pulldown current will not exceed 1.7, for device drain to source voltage from 0 to $V_{DDQ}/2$
6. The Full variation in the ratio of the nominal pullup to pulldown current should be unity $\pm 10\%$, for device drain to source voltages from 0 to $V_{DDQ}/2$

Figure 26. I/V characteristics for input/output buffers: Pull up (above) and pull down (below)

128Mb DDR SDRAM

Voltage (V)	Pulldown Current (mA)				pullup Current (mA)			
	Typical Low	Typical High	Minimum	Maximum	Typical Low	Typical High	Minimum	Maximum
0.1	3.4	3.8	2.6	5.0	-3.5	-4.3	-2.6	-5.0
0.2	6.9	7.6	5.2	9.9	-6.9	-8.2	-5.2	-9.9
0.3	10.3	11.4	7.8	14.6	-10.3	-12.0	-7.8	-14.6
0.4	13.6	15.1	10.4	19.2	-13.6	-15.7	-10.4	-19.2
0.5	16.9	18.7	13.0	23.6	-16.9	-19.3	-13.0	-23.6
0.6	19.6	22.1	15.7	28.0	-19.4	-22.9	-15.7	-28.0
0.7	22.3	25.0	18.2	32.2	-21.5	-26.5	-18.2	-32.2
0.8	24.7	28.2	20.8	35.8	-23.3	-30.1	-20.4	-35.8
0.9	26.9	31.3	22.4	39.5	-24.8	-33.6	-21.6	-39.5
1.0	29.0	34.1	24.1	43.2	-26.0	-37.1	-21.9	-43.2
1.1	30.6	36.9	25.4	46.7	-27.1	-40.3	-22.1	-46.7
1.2	31.8	39.5	26.2	50.0	-27.8	-43.1	-22.2	-50.0
1.3	32.8	42.0	26.6	53.1	-28.3	-45.8	-22.3	-53.1
1.4	33.5	44.4	26.8	56.1	-28.6	-48.4	-22.4	-56.1
1.5	34.0	46.6	27.0	58.7	-28.7	-50.7	-22.6	-58.7
1.6	34.3	48.6	27.2	61.4	-28.9	-52.9	-22.7	-61.4
1.7	34.5	50.5	27.4	63.5	-28.9	-55.0	-22.7	-63.5
1.8	34.8	52.2	27.7	65.6	-29.0	-56.8	-22.8	-65.6
1.9	35.1	53.9	27.8	67.7	-29.2	-58.7	-22.9	-67.7
2.0	35.4	55.0	28.0	69.8	-29.2	-60.0	-22.9	-69.8
2.1	35.6	56.1	28.1	71.6	-29.3	-61.2	-23.0	-71.6
2.2	35.8	57.1	28.2	73.3	-29.5	-62.4	-23.0	-73.3
2.3	36.1	57.7	28.3	74.9	-29.5	-63.1	-23.1	-74.9
2.4	36.3	58.2	28.3	76.4	-29.6	-63.8	-23.2	-76.4
2.5	36.5	58.7	28.4	77.7	-29.7	-64.4	-23.2	-77.7
2.6	36.7	59.2	28.5	78.8	-29.8	-65.1	-23.3	-78.8
2.7	36.8	59.6	28.6	79.7	-29.9	-65.8	-23.3	-79.7

Table 18. Pull down and pull up current values

Temperature (Tambient)

Typical 25°C
 Minimum 70°C
 Maximum 0°C

Vdd/Vddq

Typical 2.5V
 Minimum 2.3V
 Maximum 2.7V

The above characteristics are specified under best, worst and normal process variation/conditions

128Mb DDR SDRAM

12. \overline{QFC} function

\overline{QFC} definition

when drive low on reads coincident with the start of DQS, this DRAM output signal says that one cycle later there will be the first valid DQS output and returned to HI-Z after this finishing a burst operation. It is also driven low shortly after a write command is received and returned to HI-Z shortly after the last data strobe transition is received. Whenever the device is in standby, the signal is HI-Z. \overline{QFC} is intended to enable an external data switch. \overline{QFC} can be enabled or disabled through EMRS control.

\overline{QFC} timing on Read operation

\overline{QFC} on reads is enabled coincident with the start of DQS preamble, and disabled coincident with the end of DQS postamble

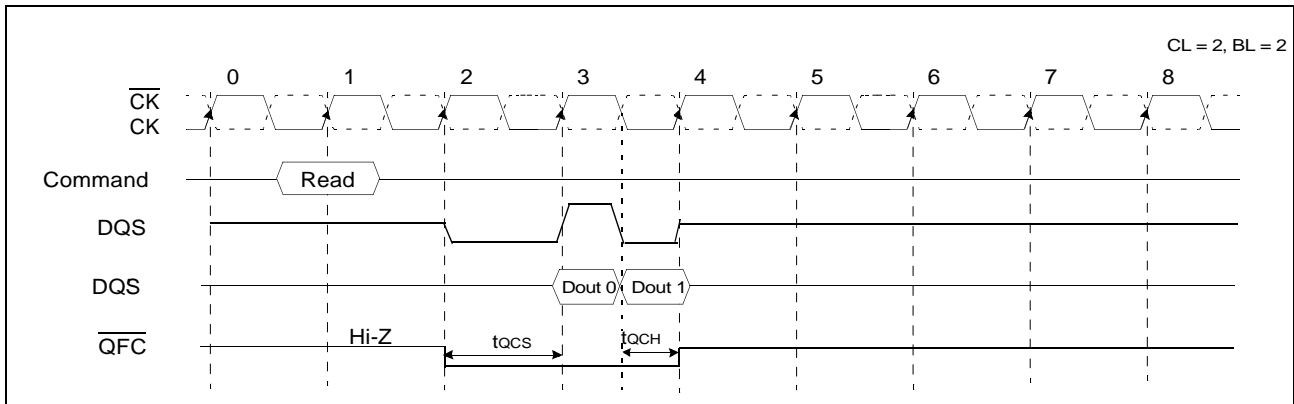

Figure 26. \overline{QFC} timing on read operation

128Mb DDR SDRAM

QFC timing on Write operation

\overline{QFC} on writes is enabled as soon as possible after the clock edge of write command and disabled as soon as possible after the last DQS-in low going edge.

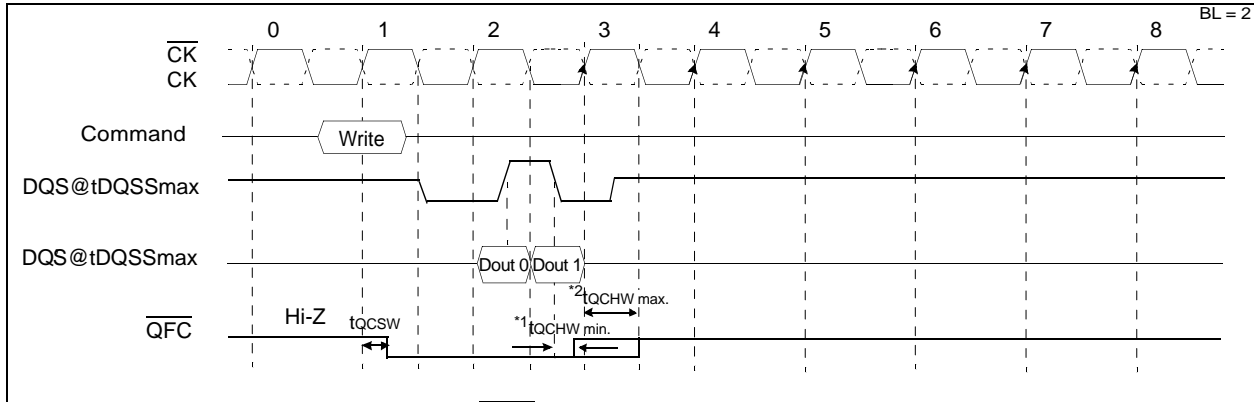

Figure 27. : QFC timing on write operation with tDQSSmax

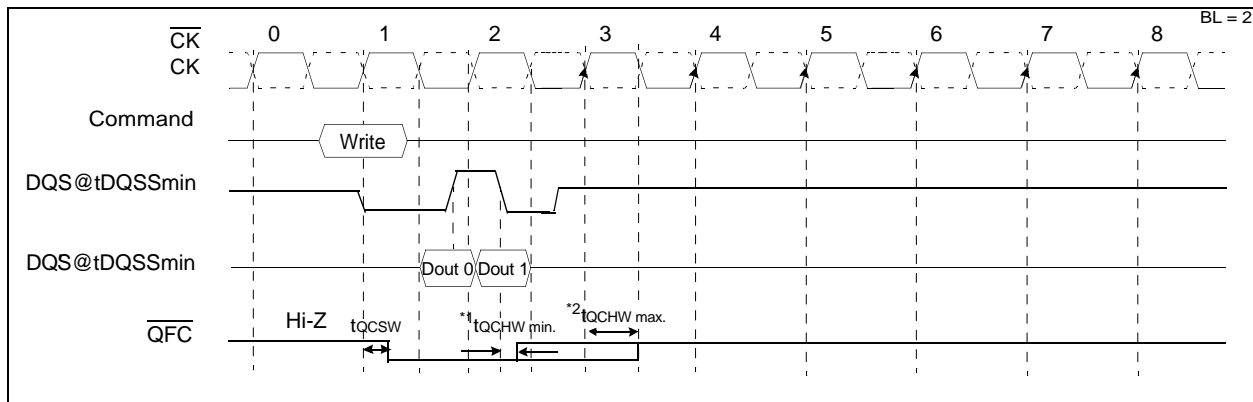

Figure 28. : QFC timing on write operation with tDQSSmin

1. The value of t_{QCSW} min. is 1.25ns from the last low going data strobe edge to \overline{QFC} tri-state.
2. The value of t_{QCSW} max. is 0.5tcK from the first high going clock edge after the last low going data strobe edge to \overline{QFC} tri-state.

128Mb DDR SDRAM

QFC timing example for interrupted Writes operation

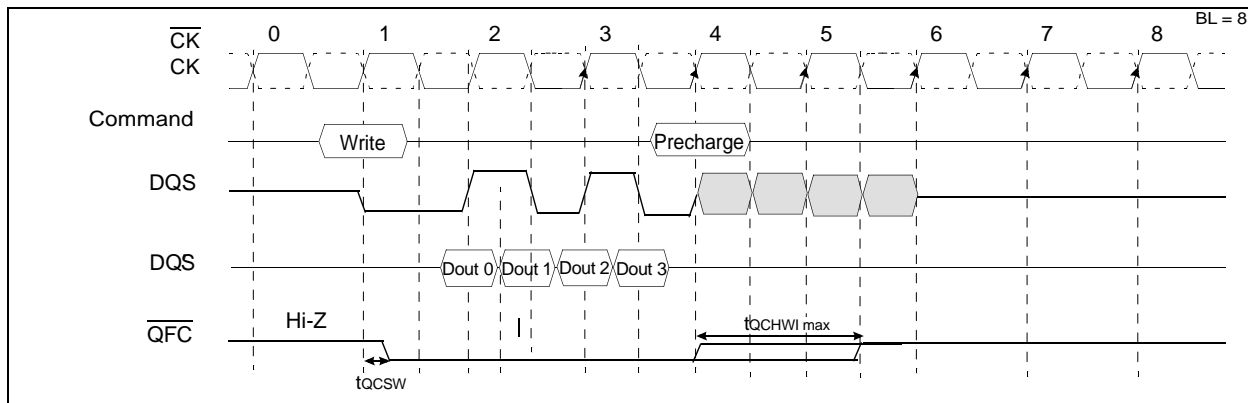

Figure 29. : QFC timing example for Interrupted writes operation

This datasheet has been downloaded from:

www.DatasheetCatalog.com

Datasheets for electronic components.



LittleDiode supplies new, hard to find or obsolete electronic components and semiconductors all over the world.

With over two million different components listed you are sure to find the part you need.

Feel free to visit us today at our online store:

LittleDiode.com

Looking forward to providing you with the best possible service.