

Document Title**256Kx16 bit Low Power full CMOS Static RAM****Revision History**

<u>Revision No.</u>	<u>History</u>	<u>Draft Date</u>	<u>Remark</u>
0.0	Initial draft	July 26, 2002	Preliminary
0.1	Revised Added Commercial Product. Deleted 44-TSOP2-400R Package Type.	November 29, 2002	Preliminary
1.0	Finalized - Changed Icc from 10mA to 5mA - Changed Icc1 from 10mA to 7mA - Changed Icc2 from 50mA to 30mA - Changed Isb from 3mA to 0.4mA - Changed IDR(Commercial) from 15 μ A to 12 μ A - Changed IDR(industrial) from 20 μ A to 12 μ A - Changed IDR(Automotive) from 30 μ A to 25 μ A	September 16, 2003	final

The attached datasheets are provided by SAMSUNG Electronics. SAMSUNG Electronics CO., LTD. reserve the right to change the specifications and products. SAMSUNG Electronics will answer to your questions about device. If you have any questions, please contact the SAMSUNG branch offices.

256Kx16 bit Low Power full CMOS Static RAM

FEATURES

- Process Technology: Full CMOS
- Organization: 256Kx16
- Power Supply Voltage: 4.5~5.5V
- Low Data Retention Voltage: 2V(Min)
- Three state output and TTL compatible
- Package Type: 44-TSOP2-400F

GENERAL DESCRIPTION

The K6X4016C3F families are fabricated by SAMSUNG's advanced full CMOS process technology. The families support various operating temperature range and small package types for user flexibility of system design. The families also support low data retention voltage for battery back-up operation with low data retention current.

PRODUCT FAMILY

Product Family	Operating Temperature	Vcc Range	Speed	Power Dissipation		PKG Type
				Standby (I _{SB1} , Max)	Operating (I _{CC2} , Max)	
K6X4016C3F-B	Commercial(0~70°C)	4.5~5.5V	55 ¹⁾ /70ns	20 μA	30 mA	44-TSOP2-400F
K6X4016C3F-F	Industrial (-40~85°C)			30 μA		
K6X4016C3F-Q	Automotive (-40~125°C)					

1. The parameter is measured with 50pF test load.

PIN DESCRIPTION

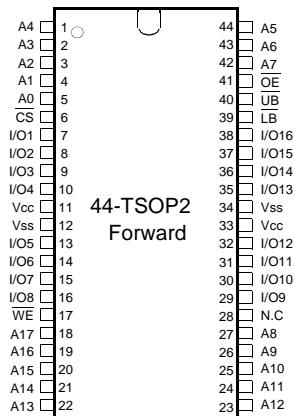

Name	Function	Name	Function
\overline{CS}	Chip Select Input	\overline{LB}	Lower Byte (I/O1-8)
\overline{OE}	Output Enable Input	\overline{UB}	Upper Byte(I/O9-16)
\overline{WE}	Write Enable Input	Vcc	Power
A0~A17	Address Inputs	Vss	Ground
I/O1~I/O16	Data Inputs/Outputs	NC	No Connection

FUNCTIONAL BLOCK DIAGRAM

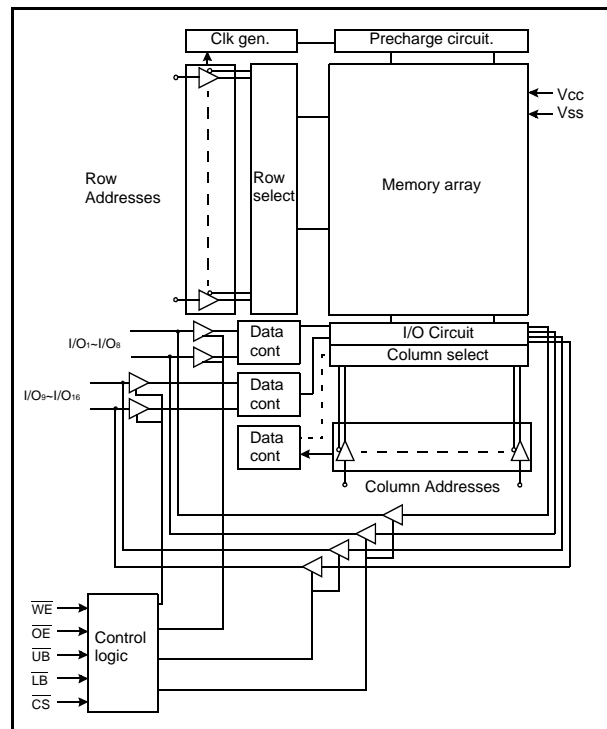

SAMSUNG ELECTRONICS CO., LTD. reserves the right to change products and specifications without notice.

PRODUCT LIST

Commercial Products(0~70°C)		Industrial Products(-40~85°C)		Automotive Products(-40~125°C)	
Part Name	Function	Part Name	Function	Part Name	Function
K6X4016C3F-TB55 K6X4016C3F-TB70	44-TSOP2-F, 55ns, LL 44-TSOP2-F, 70ns, LL	K6X4016C3F-TF55 K6X4016C3F-TF70	44-TSOP2-F, 55ns, LL 44-TSOP2-F, 70ns, LL	K6X4016C3F-TQ55 K6X4016C3F-TQ70	44-TSOP2-F, 55ns, L 44-TSOP2-F, 70ns, L

FUNCTIONAL DESCRIPTION

\overline{CS}	\overline{OE}	\overline{WE}	\overline{LB}	\overline{UB}	I/O ₁₋₈	I/O ₉₋₁₆	Mode	Power
H	X ¹⁾	X ¹⁾	X ¹⁾	X ¹⁾	High-Z	High-Z	Deselected	Standby
L	H	H	X ¹⁾	X ¹⁾	High-Z	High-Z	Output Disabled	Active
L	X ¹⁾	X ¹⁾	H	H	High-Z	High-Z	Output Disabled	Active
L	L	H	L	H	Dout	High-Z	Lower Byte Read	Active
L	L	H	H	L	High-Z	Dout	Upper Byte Read	Active
L	L	H	L	L	Dout	Dout	Word Read	Active
L	X ¹⁾	L	L	H	Din	High-Z	Lower Byte Write	Active
L	X ¹⁾	L	H	L	High-Z	Din	Upper Byte Write	Active
L	X ¹⁾	L	L	L	Din	Din	Word Write	Active

1. X means don't care. (Must be in low or high state)

ABSOLUTE MAXIMUM RATINGS¹⁾

Item	Symbol	Ratings	Unit	Remark
Voltage on any pin relative to V _{ss}	V _{IN} , V _{OUT}	-0.5 to V _{CC} +0.5V(max. 7.0V)	V	-
Voltage on V _{CC} supply relative to V _{ss}	V _{CC}	-0.3 to 7.0	V	-
Power Dissipation	P _d	1.0	W	-
Storage temperature	T _{STG}	-65 to 150	°C	-
Operating Temperature	T _A	0 to 70	°C	K6X4016C3F-B
		-40 to 85		K6X4016C3F-F
		-40 to 125		K6X4016C3F-Q

1. Stresses greater than those listed under "Absolute Maximum Ratings" may cause permanent damage to the device. Functional operation should be restricted to recommended operating condition. Exposure to absolute maximum rating conditions for extended periods may affect reliability.

RECOMMENDED DC OPERATING CONDITIONS¹⁾

Item	Symbol	Min	Typ	Max	Unit
Supply voltage	V _{CC}	4.5	5.0	5.5	V
Ground	V _{SS}	0	0	0	V
Input high voltage	V _{IH}	2.2	-	V _{CC} +0.5 ²⁾	V
Input low voltage	V _{IL}	-0.5 ³⁾	-	0.8	V

Note:

- Commercial Product: T_A=0 to 70°C, otherwise specified
Industrial Product: T_A=-40 to 85°C, otherwise specified
Automotive Product T_A=-40 to 125°C, otherwise specified
- Overshoot: V_{CC}+3.0V in case of pulse width ≤ 30ns
- Undershoot: -3.0V in case of pulse width ≤ 30ns
- Overshoot and undershoot are sampled, not 100% tested

CAPACITANCE¹⁾ (f=1MHz, T_A=25°C)

Item	Symbol	Test Condition	Min	Max	Unit
Input capacitance	C _{IN}	V _{IN} =0V	-	8	pF
Input/Output capacitance	C _{IO}	V _{IO} =0V	-	10	pF

- Capacitance is sampled, not 100% tested

DC AND OPERATING CHARACTERISTICS

Item	Symbol	Test Conditions	Min	Typ	Max	Unit	
Input leakage current	I _{LI}	V _{IN} =V _{SS} to V _{CC}	-1	-	1	μA	
Output leakage current	I _{LO}	$\overline{CS}=V_{IH}$ or $\overline{OE}=V_{IH}$ or $\overline{WE}=V_{IL}$, V _{IO} =V _{SS} to V _{CC}	-1	-	1	μA	
Operating power supply current	I _{CC}	I _{IO} =0mA, $\overline{CS}=V_{IL}$, V _{IN} =V _{IL} or V _{IH} , Read	-	-	5	mA	
Average operating current	I _{CC1}	Cycle time=1μs, 100% duty, I _{IO} =0mA $\overline{CS} \leq 0.2V$, V _{IN} ≥ 0.2V or V _{IN} ≥ V _{CC} -0.2V	-	-	7	mA	
	I _{CC2}	Cycle time=Min, 100% duty, I _{IO} =0mA, $\overline{CS}=V_{IL}$, V _{IN} =V _{IH} or V _{IL}	-	-	30	mA	
Output low voltage	V _{OL}	I _{OL} =2.1mA	-	-	0.4	V	
Output high voltage	V _{OH}	I _{OH} =-1.0mA	2.4	-	-	V	
Standby Current(TTL)	I _{SB}	$\overline{CS}=V_{IH}$, Other inputs = V _{IL} or V _{IH}	-	-	0.4	mA	
Standby Current(CMOS)	I _{SB1}	$\overline{CS} \geq V_{CC}-0.2V$, Other inputs=0~V _{CC}	K6X4016C3F-B	-	-	20	μA
			K6X4016C3F-F	-	-		
			K6X4016C3F-Q	-	-	30	μA

AC OPERATING CONDITIONS

TEST CONDITIONS (Test Load and Test Input/Output Reference)

Input pulse level: 0.8 to 2.4V
 Input rising and falling time: 5ns
 Input and output reference voltage: 1.5V
 Output load (See right): $C_L=100\text{pF}+1\text{TTL}$
 $C_L=50\text{pF}+1\text{TTL}$

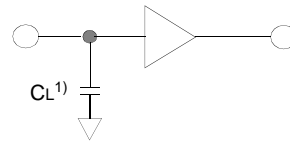

1. Including scope and jig capacitance

AC CHARACTERISTICS

($V_{CC}=4.5\text{--}5.5\text{V}$, Commercial Product: $T_A=0$ to 70°C , Industrial Product: $T_A=-40$ to 85°C , Automotive Product : $T_A=-40$ to 125°C ,)

Parameter List		Symbol	Speed Bins				Units
			55ns		70ns		
			Min	Max	Min	Max	
Read	Read cycle time	t _{RC}	55	-	70	-	ns
	Address access time	t _{AA}	-	55	-	70	ns
	Chip select to output	t _{CO}	-	55	-	70	ns
	Output enable to valid output	t _{OE}	-	25	-	35	ns
	Chip select to low-Z output	t _{LZ}	10	-	10	-	ns
	Output enable to low-Z output	t _{OLZ}	5	-	5	-	ns
	$\overline{\text{LB}}$, $\overline{\text{UB}}$ enable to low-Z output	t _{BLZ}	5	-	5	-	ns
	Chip disable to high-Z output	t _{HZ}	0	20	0	25	ns
	$\overline{\text{OE}}$ disable to high-Z output	t _{OHZ}	0	20	0	25	ns
	Output hold from address change	t _{OH}	10	-	10	-	ns
	$\overline{\text{LB}}$, $\overline{\text{UB}}$ valid to data output	t _{BA}	-	25	-	35	ns
	$\overline{\text{UB}}$, $\overline{\text{LB}}$ disable to high-Z output	t _{BHZ}	0	20	0	25	ns
Write	Write cycle time	t _{WC}	55	-	70	-	ns
	Chip select to end of write	t _{CW}	45	-	60	-	ns
	Address set-up time	t _{AS}	0	-	0	-	ns
	Address valid to end of write	t _{AW}	45	-	60	-	ns
	Write pulse width	t _{WP}	45	-	55	-	ns
	Write recovery time	t _{WR}	0	-	0	-	ns
	Write to output high-Z	t _{WHZ}	0	20	0	25	ns
	Data to write time overlap	t _{DW}	25	-	30	-	ns
	Data hold from write time	t _{DH}	0	-	0	-	ns
	End write to output low-Z	t _{OW}	5	-	5	-	ns
$\overline{\text{LB}}$, $\overline{\text{UB}}$ valid to end of write	t _{BW}	45	-	60	-	ns	

DATA RETENTION CHARACTERISTICS

Item	Symbol	Test Condition	Min	Typ	Max	Unit
V _{CC} for data retention	V _{DR}	$\overline{\text{CS}} \geq V_{CC}-0.2\text{V}$	2.0	-	5.5	V
Data retention current	I _{DR}	$V_{CC}=3.0\text{V}$, $\overline{\text{CS}} \geq V_{CC}-0.2\text{V}$		-	12	μA
					12	
					25	
Data retention set-up time	t _{SDR}	See data retention waveform	0	-	-	ms
Recovery time	t _{RDR}		5	-	-	

TIMING DIAGRAMS

TIMING WAVEFORM OF READ CYCLE(1) (Address Controlled, $\overline{CS}=\overline{OE}=V_{IL}$, $\overline{WE}=V_{IH}$, \overline{UB} or/and $\overline{LB}=V_{IL}$)

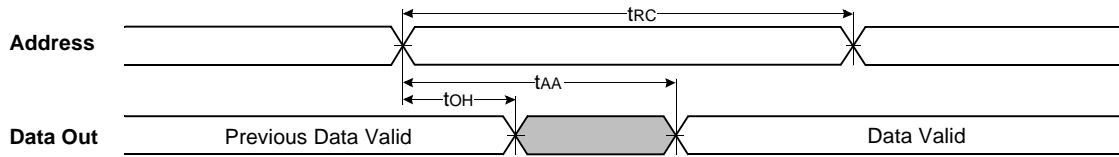

TIMING WAVEFORM OF READ CYCLE(2) ($\overline{WE}=V_{IH}$)

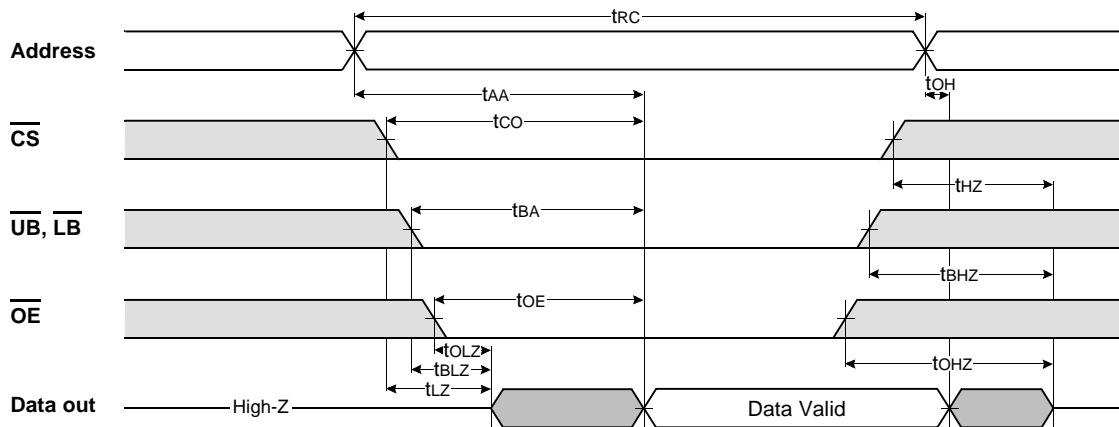

NOTES (READ CYCLE)

1. t_{HZ} and t_{OHZ} are defined as the time at which the outputs achieve the open circuit conditions and are not referenced to output voltage levels.
2. At any given temperature and voltage condition, $t_{HZ}(\text{Max.})$ is less than $t_{LZ}(\text{Min.})$ both for a given device and from device to device interconnection.

TIMING WAVEFORM OF WRITE CYCLE(1) (\overline{WE} Controlled)

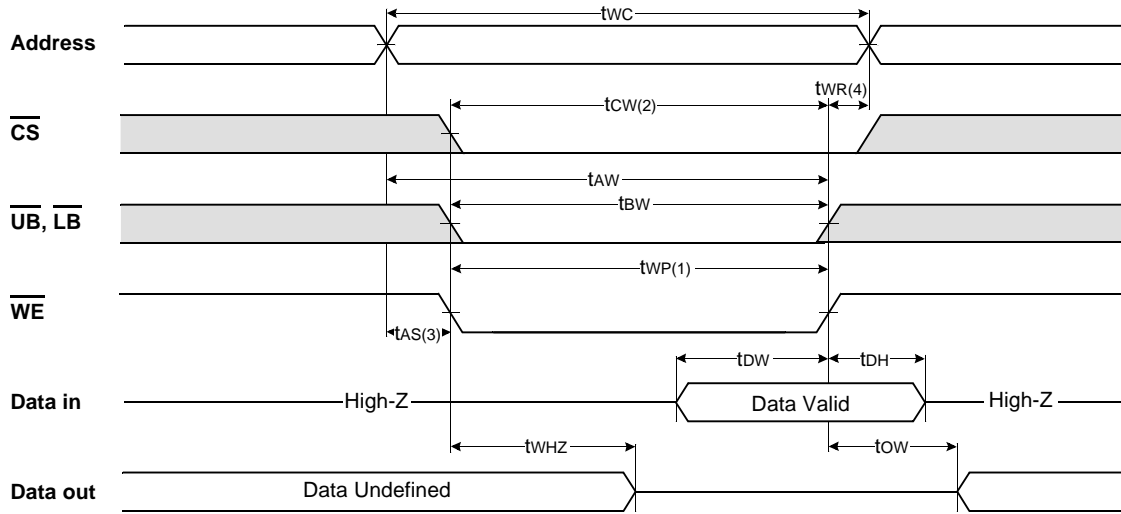

TIMING WAVEFORM OF WRITE CYCLE(2) (\overline{CS} Controlled)

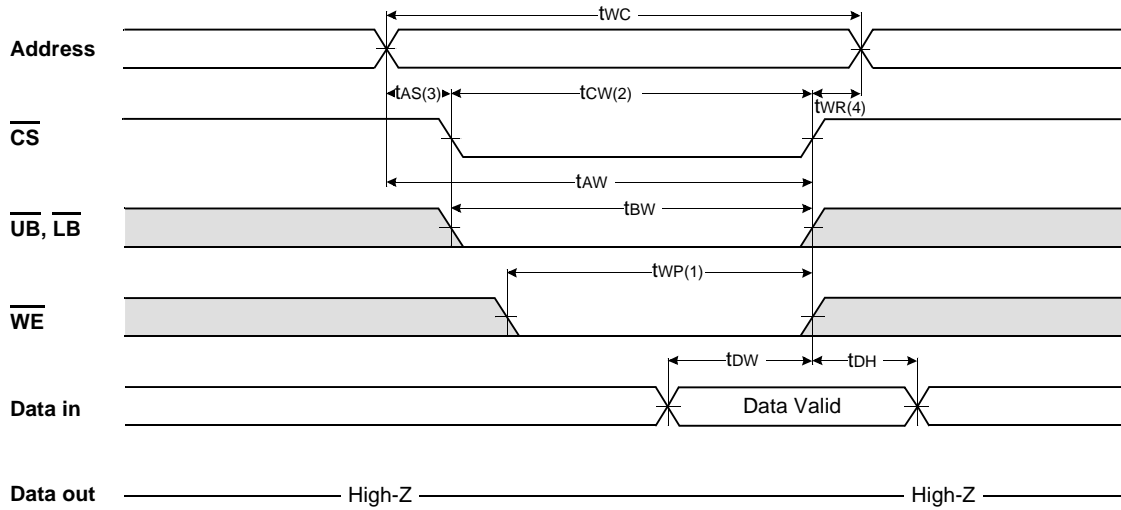

TIMING WAVEFORM OF WRITE CYCLE(3) (\overline{UB} , \overline{LB} Controlled)

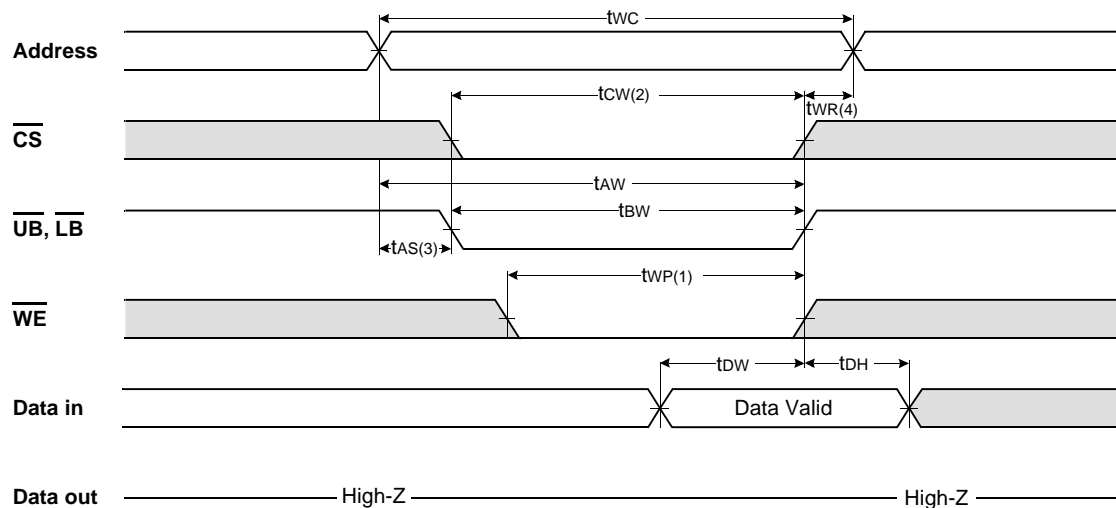

NOTES (WRITE CYCLE)

1. A write occurs during the overlap(t_{WP}) of low \overline{CS} and low \overline{WE} . A write begins when \overline{CS} goes low and \overline{WE} goes low with asserting \overline{UB} or \overline{LB} for single byte operation or simultaneously asserting \overline{UB} and \overline{LB} for double byte operation. A write ends at the earliest transition when \overline{CS} goes high and \overline{WE} goes high. The t_{WP} is measured from the beginning of write to the end of write.
2. t_{CW} is measured from the \overline{CS} going low to the end of write.
3. t_{AS} is measured from the address valid to the beginning of write.
4. t_{WR} is measured from the end of write to the address change. t_{WR} applied in case a write ends as \overline{CS} or \overline{WE} going high.

DATA RETENTION WAVE FORM

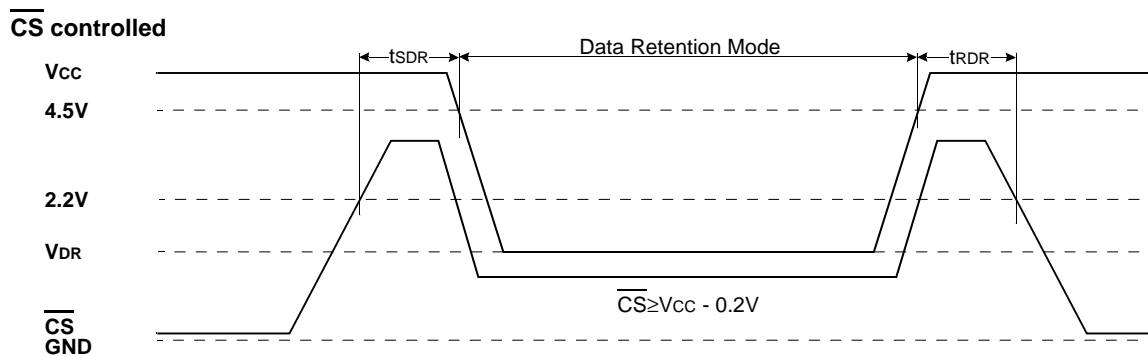

PACKAGE DIMENSIONS

Units: millimeter(inch)

44 PIN THIN SMALL OUTLINE PACKAGE TYPE II (400F)

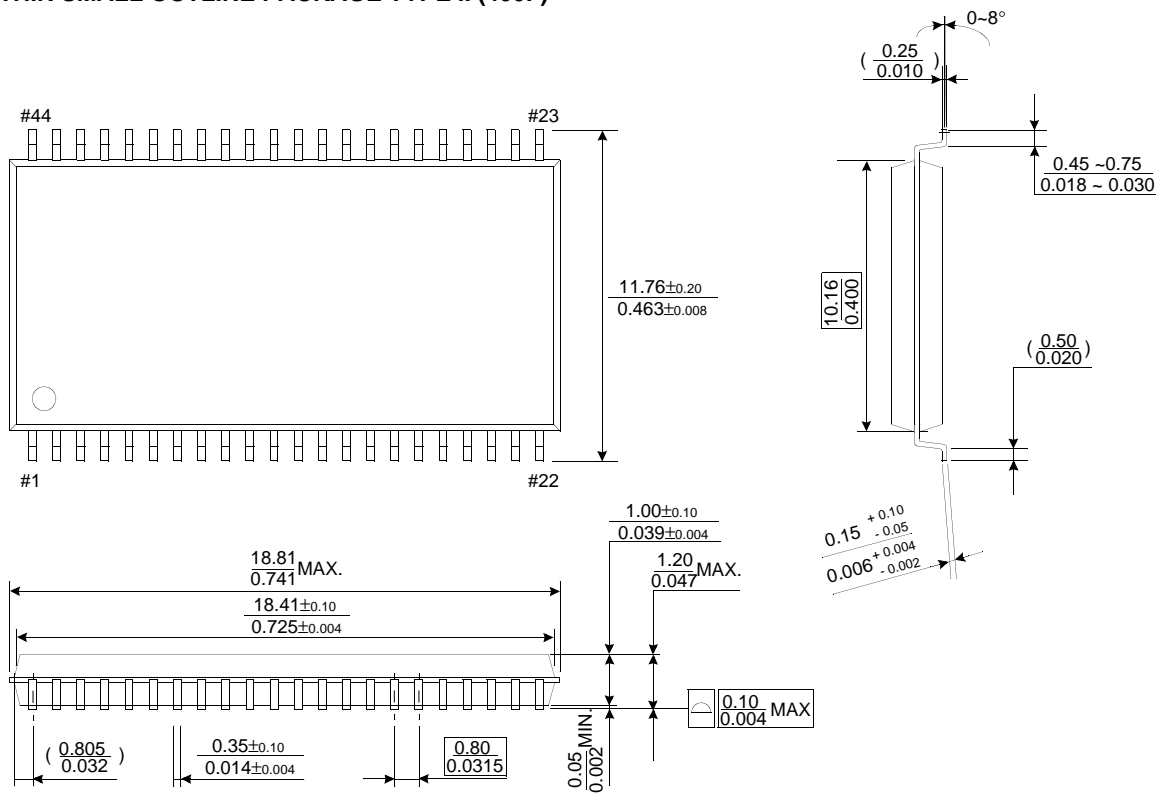

This datasheet has been downloaded from:

www.DatasheetCatalog.com

Datasheets for electronic components.



LittleDiode supplies new, hard to find or obsolete electronic components and semiconductors all over the world.

With over two million different components listed you are sure to find the part you need.

Feel free to visit us today at our online store:

LittleDiode.com

Looking forward to providing you with the best possible service.