

**DC VOLUME, TONE CONTROL CIRCUIT**

The KA2107 is a monolithic integrated circuit designed for 2 channel volume and tone control.

**FUNCTIONS**

- DC Volume Control
- DC Tone Control (Bass & Treble)
- Balance Control (R, L-Ch)

**FEATURES**

- Easier compact set design
- All function enable DC controllable

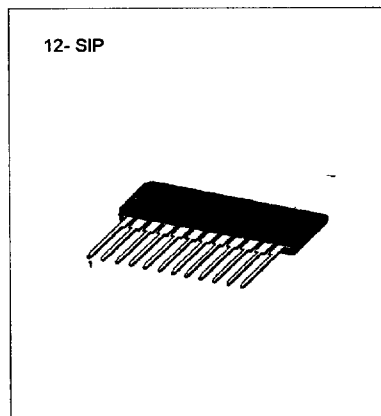

**BLOCK DIAGRAM**

**ORDERING INFORMATION**

Device	Package	Operating Temperature
KA2107	12-SIP	-20°C~+70°C

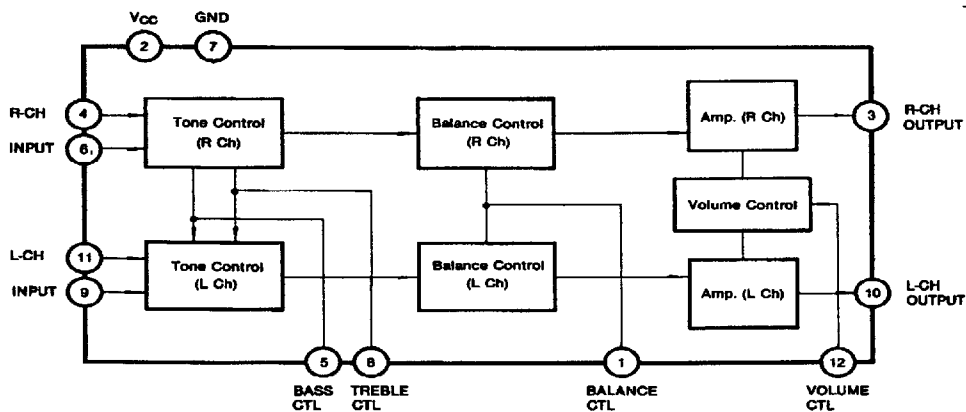

Fig. 1

**ABSOLUTE MAXIMUM RATINGS (T<sub>A</sub> =25°C)**

Characteristic		Symbol	Value		Unit
Voltage	Supply Voltage	V <sub>CC</sub>	14.4		V
	Circuit Voltage	V <sub>1,4,5,6,7</sub> V <sub>8,9,11,12,7</sub>	0	V <sub>2,7</sub>	V
Current	Supply Current	I <sub>2</sub>	64		mA
	Circuit Current	I <sub>3,10</sub>	-40	—	mA
Power Dissipation		P <sub>D</sub>	920		mW
Temperature	Operating Temperature	T <sub>OPR</sub>	-20~+70		°C
	Storage Temperature	T <sub>STG</sub>	-55~+150		°C

**ELECTRICAL CHARACTERISTICS (V<sub>CC</sub> =12V, T<sub>A</sub> =25°C)**

Characteristic	Symbol	Condition	Min	Typ	Max	Unit	Test Circuit	
Supply Current	I <sub>TOT</sub>	V <sub>CC</sub> =12V	24	38	50	mA	1	
Supply Voltage	V <sub>3, 10-7</sub>	No input, V <sub>12</sub> =V <sub>CC</sub> , V <sub>1</sub> =V <sub>5</sub> =V <sub>8</sub> =V <sub>CC</sub> /2	8.0	8.4	8.8	V	2	
Volume	Max Output Voltage	V <sub>OMAX</sub>	f=1KHz, V <sub>i</sub> =400mV <sub>ms</sub>	190	230	270	μV <sub>ms</sub>	2
	Channel Balance	CB	V <sub>12</sub> =V <sub>CC</sub> , V <sub>1</sub> =V <sub>5</sub> =V <sub>8</sub> =V <sub>CC</sub> /2	—	+0.2	±1.0	dB	2
	Output Starting Voltage	V <sub>(ST)</sub>	f=1KHz, V <sub>i</sub> =400mV <sub>ms</sub> V <sub>12</sub> =V <sub>R</sub> , V <sub>1</sub> =V <sub>5</sub> =V <sub>8</sub> =V <sub>CC</sub> /2	0.40	0.65	0.90	V	2
	Residual Noise Level	V <sub>MIN</sub>	f=1KHz, V <sub>i</sub> =400mV <sub>ms</sub> V <sub>12</sub> =0V, V <sub>1</sub> =V <sub>5</sub> =V <sub>8</sub> =V <sub>CC</sub> /2	—	25	50	μV <sub>ms</sub>	2
Balance	Attenuation (R-Ch)	ATT <sub>R</sub>	f=1KHz, V <sub>i</sub> =400mV <sub>ms</sub> , V <sub>12</sub> =V <sub>CC</sub> , V <sub>5</sub> =V <sub>8</sub> =V <sub>CC</sub> /2, V <sub>OR</sub> :V <sub>1</sub> =(6.5/12) · V <sub>CC</sub> (at VR · 1), V <sub>OR2</sub> :V <sub>1</sub> =0V	-32	-45	—	dB	2
	Attenuation (L-Ch)	ATT <sub>L</sub>	f=1KHz, V <sub>i</sub> =400mV <sub>ms</sub> , V <sub>12</sub> =V <sub>CC</sub> , V <sub>5</sub> =V <sub>8</sub> =V <sub>CC</sub> /2, V <sub>OL1</sub> :V <sub>1</sub> =(6.5/12) · V <sub>CC</sub> (at VR · 1), V <sub>OL2</sub> :V <sub>1</sub> =V <sub>CC</sub>	-32	-45	—	dB	2
Tone	Low Frequency Boost Control	V <sub>40</sub> /V <sub>1K</sub>	V <sub>1K</sub> : Output Voltage at f=1KHz, V <sub>i</sub> =400mV <sub>ms</sub> V <sub>12</sub> =V <sub>CC</sub> , V <sub>1</sub> =V <sub>5</sub> =V <sub>8</sub> =V <sub>CC</sub> /2 V <sub>40</sub> : Output Voltage at f=40Hz, V <sub>i</sub> =40mV <sub>ms</sub> V <sub>12</sub> =V <sub>CC</sub> , V <sub>5</sub> =V <sub>8</sub> =V <sub>CC</sub>	8	10	12	dB	2
	Low Frequency Cut Control	V <sub>40</sub> /V <sub>1K</sub>	V <sub>1K</sub> : Output Voltage at f=1KHz, V <sub>i</sub> =400mV <sub>ms</sub> V <sub>12</sub> =V <sub>CC</sub> , V <sub>1</sub> =V <sub>5</sub> =V <sub>8</sub> =V <sub>CC</sub> /2 V <sub>40</sub> : Output Voltage at f=40Hz, V <sub>i</sub> =40mV <sub>ms</sub> V <sub>12</sub> =V <sub>CC</sub> , V <sub>5</sub> =V <sub>8</sub> =0V	-7.5	-12	-16	dB	2
	High Frequency Boost Control	V <sub>15K</sub> /V <sub>1K</sub>	V <sub>1K</sub> : Output Voltage at f=1KHz, V <sub>i</sub> =400mV <sub>ms</sub> V <sub>12</sub> =V <sub>CC</sub> , V <sub>1</sub> =V <sub>5</sub> =V <sub>8</sub> =V <sub>CC</sub> /2 V <sub>15K</sub> : Output Voltage at f=15KHz, V <sub>i</sub> =40mV <sub>ms</sub> V <sub>12</sub> =V <sub>CC</sub> , V <sub>5</sub> =V <sub>8</sub> =V <sub>CC</sub>	7.5	10	13	dB	2
	High Frequency Cut Control	V <sub>15K</sub> /V <sub>1K</sub>	V <sub>1K</sub> : Output Voltage at f=1KHz, V <sub>i</sub> =400mV <sub>ms</sub> V <sub>12</sub> =V <sub>CC</sub> , V <sub>1</sub> =V <sub>5</sub> =V <sub>8</sub> =V <sub>CC</sub> /2 V <sub>15K</sub> : Output Voltage at f=40Hz, V <sub>i</sub> =40mV <sub>ms</sub> V <sub>12</sub> =V <sub>CC</sub> , V <sub>5</sub> =V <sub>8</sub> =0V	-7.5	-12	-18	dB	2

**ELECTRICAL CHARACTERISTICS (Continued)**

Characteristic	Symbol	Condition	Min	Typ	Max	Unit	Test Circuit
Cross Talk	CT	$f = 1\text{KHz}$ , $V_i = 400\text{mV}_{\text{RMS}}$ $V_{12} = V_{\text{CC}}$ , $V_1 = V_5 = V_8 = V_{\text{CC}}/2$	-65	-80	-	dB	2
Output Noise Voltage	$V_{\text{NO}}$	No input, $V_{12} = V_{\text{CC}}$ , $V_1 = V_5 = V_8 = V_{\text{CC}}/2$	-	80	120	$\mu\text{V}_{\text{RMS}}$	2
Total Harmonic Distortion	THD	$f = 1\text{KHz}$ , $V_i = 400\text{mV}_{\text{RMS}}$ $V_{12} = V_{\text{CC}}$ , $V_1 = V_5 = V_8 = V_{\text{CC}}/2$	-	0.2	0.5	%	2
Input Resistance	$R_{i(6),(9)}$	$f = 1\text{KHz}$	8.2	11.0	13.5	k $\Omega$	
	$R_{i(4),(11)}$		11.0	16.0	22.0	k $\Omega$	
Output Resistance	$R_{o(3),(10)}$	$f = 1\text{KHz}$	60	110	160	$\Omega$	

**TEST CIRCUIT**

**Test Circuit 1 ( $I_{\text{CC}}$ )**

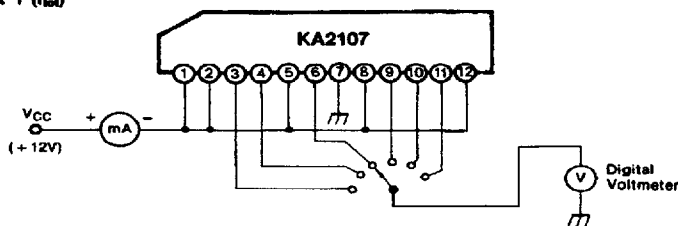

**Test Circuit 2 ( $V_3$ , 10-7,  $V_{\text{OMAX}}$ , CB,  $V_{\text{BT}}$ ,  $V_{\text{MIN}}$ , ATT<sub>R</sub>, ATT<sub>L</sub>,  $V_{40}/V_{1K}$ ,  $V_{15K}/V_{1K}$ , CT,  $V_{\text{NO}}$ , THD)**

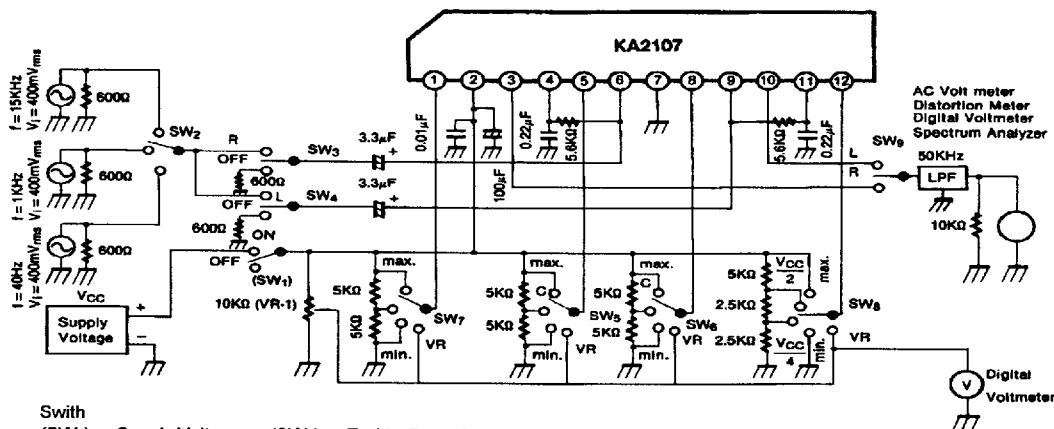

- Swiath  
 (SW<sub>1</sub>) ... Supply Voltage      (SW<sub>8</sub>) ... Treble Control  
 (SW<sub>2</sub>) ... Input Signal        (SW<sub>7</sub>) ... Treble Control  
 (SW<sub>3</sub>) ... R Side Input        (SW<sub>6</sub>) ... Treble Control  
 (SW<sub>4</sub>) ... L Side Input        (SW<sub>5</sub>) ... Treble Control  
 (SW<sub>5</sub>) ... Bass Control

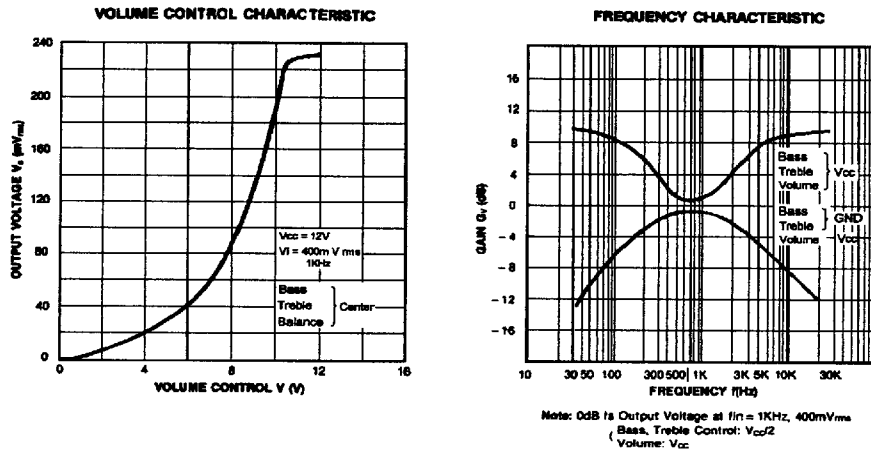

**TYPICAL APPLICATION CIRCUIT**

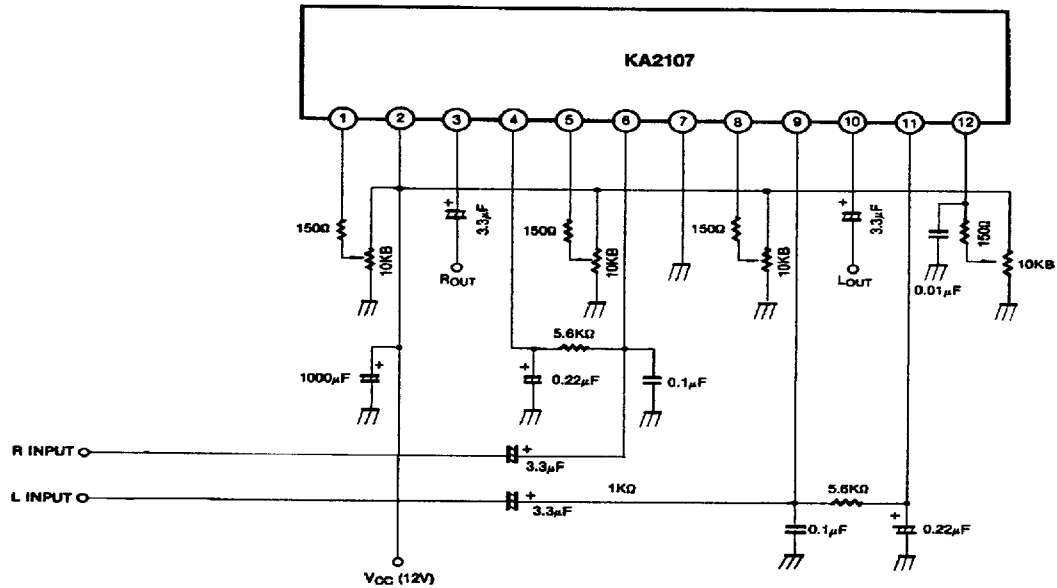

Fig.3

Dimensions in Millimeters

