

I²C BUS NTSC 1 CHIP FOR COLOR TV

The KA2163 is a monolithic integrated circuit for VIF, SIF, chroma and deflection circuit of NTSC color TV. The KA2163 also provides audio / video switch and OSD interface. It combines these functions in a 56 SDIP package and the KA2163B also includes I²C bus control functions for automatically adjustment.

FUNCTIONS

- VIF/SIF
- Video
- Chroma
- Deflection
- OSD interface
- I²C bus circuit

FEATURES

VIF CIRCUIT

- PLL type IF demodulation (bus alignment)
- Adjustment free AFT without tank coil
- RF AGC output (delay point : bus alignment)
- Dual time constant fast AGC

SIF CIRCUIT

- Inter carrier SIF system
- External sound select switch (bus select)
- Attenuator circuit

VIDEO CIRCUIT

- Black stretcher
- DC Restoration circuit
- D.L aperture compensate circuit (bus control)
- Internal filter auto-adjust circuit (fsc link type)
- Uni-color circuit(bus control)
- Y delay line circuit

CHROMA CIRCUIT

- Color control circuit (bus control)
- Tint control circuit

56-SDIP-600

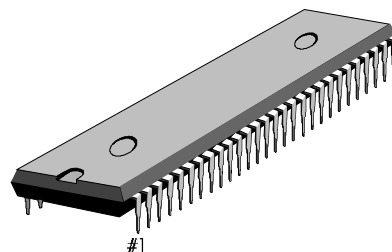

ORDERING INFORMATION

Device	Package	Operating Temperature
KA2163	56 -SDIP	-20°C ~ +65°C

OSD CIRCUIT

- Linear RGB input
- Cut off / Drive adjustment (bus adjustment)
- RGB primary color output

DEFLECTION CIRCUIT

- Auto-slicer type high performance
- Sync. separator circuit
- Adjustment free countdown system
- Sync. separation output
- X-ray protect circuit
- Vertical ramp output
- Dual time constant AFC circuit
- Horizontal and Vertical position bus adjustment
- Vertical amplitude adjustment (bus adjustment)

TERMINAL FUNCTION

PIN NO.	PIN NAME	FUNCTION	INTERFACE CIRCUIT
1 2	Sound Output	This terminal is for Sound Output. The maximum flew out current of these terminals is 3.6mA. So, the minimum load resister is 1k Ω .	
3	RF AGC	This terminal is for RF AGC output.	
4	SIF Tank Coil	This terminal is for connecting SIF detect tank coil. This terminal is for Sound Mute Switch, too. If this terminal is connected to GND, the sound output is muted.	
5	AGC Filter	This terminal is for PIF 2nd AGC filter.	
6	PIF GND	This terminal is for GND of PIF circuit.	—
7 8	PIF Input	This terminal is for IF input. The typical input value is 90dB μ V.	

PIN NO.	PIN NAME	FUNCTION	INTERFACE CIRCUIT
9	PIF Vcc	This terminal is for Vcc of PIF circuit.	—
10	Loop Filter	This terminal is for PIF PLL loop filter.	
11	APC Filter	This terminal is for APC filter of fsc oscillation.	
12	VCXO	This terminal is for X ^{tal} of 3.58MHz VCXO.	
13	GND	This terminal is for V/C/D GND.	—
14	Fast Blanking	This terminal is for fast blanking of RGB input.	

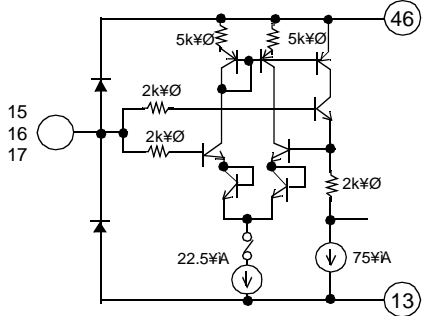
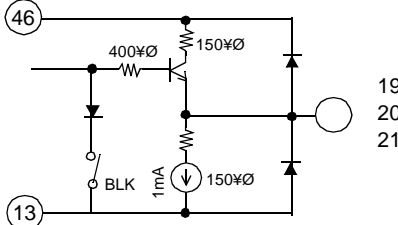
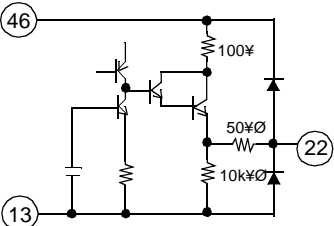
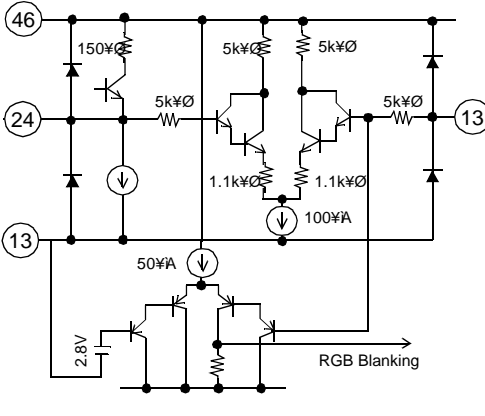
PIN NO.	PIN NAME	FUNCTION	INTERFACE CIRCUIT
15 16 17	Analog RGB Input	These terminals are for RGB signal input.	
18	Digital Vcc	This terminal is for Vcc of digital circuit.	—
19 20 21	RGB Output	This terminal is for RGB primary color signal output.	
22	Vertical Output	This terminal is for vertical pulse output.	
23 24	NFB, Vertical Ramp.	These terminals are for NFB input and vertical ramp output.	

PIN NO.	PIN NAME	FUNCTION	INTERFACE CIRCUIT
25	Vertical Sync. Separation Filter	This terminal is for vertical sync. separation filter.	
26	H. Vcc	This terminal is for Vcc of horizontal circuit	—
27 28	SCL, SDA	These terminals are for input and output of I ² C Bus.	
29	X-RAY	This terminal is for input of X-RAY protect signal. The threshold voltage is 3.5V (Typ.). If applied voltage is more than threshold voltage, the X-RAY protect circuit will make horizontal output a low.	
30	Fly-back Pulse Input	This terminal is for Fly-back pulse input. The Fly-back pulse is the reference of AFC circuit, gate pulse and so on. The current needs to keep under 1mA.	
31	Sync. Pulse Output	This terminal is for Sync. pulse output.	

PIN NO.	PIN NAME	FUNCTION	INTERFACE CIRCUIT
32	Horizontal Output	This terminal is for horizontal pulse output.	
33	H. AFC	This terminal is for horizontal AFC filter. The AFC circuit fits the phase between inputted horizontal sync. signal and horizontal pulse which is made by countdown 32fH.	
34	32fH VCO	This terminal is for connecting ceramic oscillator. That constitutes 32fH (503kHz) oscillation circuit. The CSB503F30 (Murata) is recommended.	
35	D. GND	This terminal is for GND of digital circuit.	—
36	A.B.L	This terminal is for A.B.L circuit.	
37	TV Input	This terminal is for input of PIF detected signal. The typical input amplitude is 1.0Vp-p.	

PIN NO.	PIN NAME	FUNCTION	INTERFACE CIRCUIT
38	A.C.L	This terminal is for ACL circuit	
39	External Video Input	This terminal is for input of external video signal.	
40	Black Peak Detection	This terminal is for filter of black peak detection.	
41	Video Switch Output	This terminal is for output of video switch which selects TV signal or external video. Amplifier Gain is (Min.) 1.7 (Typ.) 1.9, (Max.) 2.1 .	
42	D.C. Restoration	This terminal is for filter of APL detection.	

PIN NO.	PIN NAME	FUNCTION	INTERFACE CIRCUIT															
43	Y Input	This terminal is for Y signal input. The typical input amplitude is 1.0Vp-p.																
44	A.F.T.	This terminal is for AFT output. Monitor signal output mode can be selected via Bus. <table border="1" style="margin: 10px auto;"> <thead> <tr> <th>B0</th> <th>B1</th> <th>OUTPUT</th> </tr> </thead> <tbody> <tr> <td>0</td> <td>0</td> <td>AFT</td> </tr> <tr> <td>0</td> <td>1</td> <td>TEST purpose only</td> </tr> <tr> <td>1</td> <td>0</td> <td>B</td> </tr> <tr> <td>1</td> <td>1</td> <td>RF AGC/2</td> </tr> </tbody> </table>	B0	B1	OUTPUT	0	0	AFT	0	1	TEST purpose only	1	0	B	1	1	RF AGC/2	
B0	B1	OUTPUT																
0	0	AFT																
0	1	TEST purpose only																
1	0	B																
1	1	RF AGC/2																
45	Chroma Input	This terminal is for chrominance signal input. The typical input signal amplitude is 286mVp-p (at burst signal). This IC is to go to test mode with this terminal voltage higher than 4.5V.																
46	V / C / D Vcc	This terminal is for Vcc of video, Chroma and Deflection circuit.	—															
47	TV Detection Output	This terminal is for PIF detected signal output.																
48	S.I.F. Vcc	This terminal is for Vcc of SIF circuit.	—															

PIN NO.	PIN NAME	FUNCTION	INTERFACE CIRCUIT
49 50	P.I.F. Tank Coil	These terminals are for connecting a tank coil of PIF detection circuit. TOKO Corp. products 292GJAS-7475BS(45.75MHz), 292GJAS-7476BS (58.75MHz) are recommended.	
51	S.I.F. GND	This terminal is for GND of SIF circuit.	—
52	Limiter Input	This terminal is for input of SIF limiter amplifier circuit.	
53	TV Audio Signal Input	This terminal is for input of SIF detected signal. This terminal is connected to pin 54 via capacitor.	
54	De-emphasis	This terminal for filter of SIF de-emphasis.	
55 56	External Audio Input	These terminals are for external audio input.	

Slave address : 88H

SUB ADDRESS	D7	D6	D5	D4	D3	D2	D1	D0	PRESET
00	Trap	Color							0000 0000
01	C.Filter	Tint							1100 0000
02	A. SW	Brightnes							0000 0000
03	BLK	Uni-color							0000 0000
04	Mute		Sharpness					0110 0000	
05	Vertical Phase			Horizontal Phase				0001 0000	
06	B0	B1	Audio Attenuator					0000 0000	
07	B2	B3	DONT USE (Fix on 100000)					0010 0000	
08	B4	V. SW	RF AGC					0000 0000	
09	AFC	WPL	Vertical Amplitude					0010 0000	
0A	V.Fixed	PIF VCO						0100 0000	
0B	R Cut OFF							0000 0000	
0C	G Cut OFF							0000 0000	
0D	B Cut Off							0000 0000	
0E	R Gain							0000 0000	
0F	B Gain							0000 0000	

FUNCTION	RANGE (MIN. ~ MAX.)	DEFAULT
Color	-60 ~ 0dB	-60dB
TINT	0 ~ 42%	0%
Brightness	1.34 ~ 2.6 ~ 3.86V	1.34V
Uni-Color	-24 ~ 0dB	-24dB
Sharpness	-18 ~ 6dB ~ 14dB (4MHz Gain)	6dB
Audio ATT	-85 ~ 6dB	-85dB
RF AGC	65dB ~ 105dB (0.6dB / bit), 000000 : IF Mute	IF Mute
Ver. Amplitude	1.6 ~ 2.4V	Center
PIF VCO	0 ~ 2.2MHz (35kHz / bit)	Center
RGB Cut-off	-0.4 ~ 0.4V	-0.4V
RB Gain	-3.1 ~ 3.1dB	-3.1dB

FUNCTION	RANGE (MIN. ~ MAX.)	DEFAULT
3.58 Trap	(0) : On / (1) : Off	On
Chroma Filter	(0) : Band Pass Filter / (1) : Take Off Filter	TOF
A, V SW	(0) : TV Mode / (1) : EXT. Mode	TV
BLK	(0) : BLK On / (1) : BLK Off	On
MUTE	(00) : Off / (01) : Y MUTE / (10) : Hout Stop / (11) : Y MUTE + V Stop	(01)
H. AFC	(0) : AFC2 Normal / (1) : AFC2 x 3	(0)
WPL	(0) : On / (1) : Off	Off
V. Fixed Mode	(0) : Normal / (1) : V Frequency 60Hz Fix	Normal
B0, B1 (Monitor)	Pin 44's output is selectable. (00) : AFT Voltage / (01) : Test Mode / (10) : Blue Output / (11) : Half of RF AGC Voltage	AFT Voltage
B2, B3, B4 (Test Mode)	Bits for Test Mode. Use this IC with these bits (000).	(000)

Read Mode

D7	D6	D5	D4	D3	D2	D1	D0
POR	AFT	IF Lock	AFT	-	V Lock	H Lock	X-RAY

FUNCTION	CONTENTS
POR (Power On Reset)	(0) : SECOND / (1) : FIRST
AFT	Refer to Following Figure
IF LOCK	(0) : LOCK OUT / (1) : LOCK IN
V LOCK	(0) : LOCK IN / (1) : LOCK OUT Det. Window : 262H ~ 263H
H LOCK	(0) : LOCK OUT / (1) : LOCK IN This function is forced to unlock at Vp, so data is valid after 50H.
X-RAY	(0) : X-RAY OFF / (1) : X-RAY ON

Vertical Phase (3bit)

This mode is for changing vertical output timing.
(Vertical picture position is changed 0 ~ 7H as right Table.)

Horizontal Phase (5bit)

This mode is for changing horizontal picture position.
Horizontal output phase is changed 1/4 3/8 as maximum.

AFT Read Bus

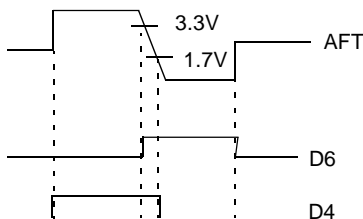

D7	D6	D5	MODE
0	0	0	Reference
0	0	1	1H Delay
0	1	0	2H Delay
0	1	1	3H Delay
1	0	0	4H Delay
1	0	1	5H Delay
1	1	0	6H Delay
1	1	1	7H Delay

MAXIMUM RATING (Ta = 25°C)

CHARACTERISTIC	SYMBOL	RATING	UNIT
Power Supply Voltage	V _{cc}	12	V
Power Dissipation	PD _{max}	2.19 (Note1)	W
Input Terminal Voltage	V _{in}	GND - 0.3 ~ V _{cc} + 0.3	V
Input Signal Amplitude	e _{in}	4	V _{p-p}
Operating Temperature	T _{opr}	-20 ~ 65	°C
Storage Temperature	T _{stg}	-55 ~ 150	°C

(Note 1) When using the device at above Ta = 25°C, decrease the power dissipation by 17.5mW for each increase of 1°C.

(Note 2) As this IC is weak in a surge voltage, handle it with care from being damage.

RECOMMENDED OPERATING CONDITION

CHARACTERISTIC	SYMBOL	MIN.	TYP.	MAX.	UNIT	REMARKS
PIF Power Supply Voltage	V _{CCP}	8.5	9.0	9.5	V	-
SIF Power Supply Voltage	V _{CCS}	8.5	9.0	9.5	V	-
V/C/D Power Supply Voltage	V _{CCV}	8.5	9.0	9.5	V	-
H.Vcc Power Supply Voltage	H.V _{CC}	8.5	9.0	9.5	V	-
D.Vcc Power Supply Voltage	D.V _{CC}	2.7	3.3	3.8	V	-
TV External Video Input Level	V _{in37/39}	-	1.0	-	V _{p-p}	including sync.
Standard Video Input Level	V _{in43}	-	1.0	-	V _{p-p}	including sync.
Standard Chroma Input Level	V _{in45}	-	286	-	mV _{p-p}	at burst signal
FBP Width	TFBP	10	12	-	µs	V _{th} = 1.4V, V _{cc} - 1.4V
FBP Input Flow in Current	IFBP _{max}	-	-	2	mA	-
PIF Output Load Resister	ROP	2	8.2	-	kΩ	-
SIF Output Load Resister	ROS	1	8.2	-	kΩ	-
RGB Output Load Resister	RORGB	-	1.8	-	kΩ	-
Horizontal Output Load Resistor	RHOUT	330	800	-	Ω	maximum 10mA
Vertical Output Load Resister	RVOUT	4.1	5.7	-	kΩ	-
Sync. Separation Output Flow In Current	Isync _{max}	-	-	1	mA	-

ELECTRICAL CHARACTERISTICS

DC CHARACTERISTICS (Unless Otherwise Specified, V_{CC} = 9V, Ta = 25°C)

PIN No.	CHARACTERISTIC	SYMBOL	TEST CONDITION	MIN.	TYP.	MAX.	UNIT
2	Sound Output	V ₂	-	3.20	3.70	4.20	V
3	RF AGC	V ₃	-	-	0.00	0.50	V
4	SIF TANK	V ₄	-	-	-	-	V
5	AGC Filter	V ₅	-	7.00	7.50	8.00	V
6	PIF GND	GND	-	-	0.00	-	V
7	PIF Input	V ₇	-	1.50	2.00	2.50	V
8	PIF Input	V ₈	-	-	0.00	0.50	V
9	PIF Vcc	V _{CC}	-	-	9.00	-	V
10	Loop Filter	V ₁₀	-	-	4.50	-	V
11	APC Filter	V ₁₁	-	6.00	6.50	7.00	V
12	VCXO	V ₁₂	-	5.30	5.80	6.30	V
13	V/C/D GND	GND	-	-	0.00	-	V
14	F-BLK	V ₁₄	-	-	0.00	-	V
15	Analog R Input	V ₁₅	-	4.40	4.90	5.40	V
16	Analog G Input	V ₁₆	-	4.40	4.90	5.40	V
17	Analog B Input	V ₁₇	-	4.40	4.90	5.40	V
18	D.Vcc	V _{CC}	-	-	3.30	-	V
19	R Output	V ₁₉	BRT, C. O Cent	2.40	2.70	2.90	V
20	G Output	V ₂₀	BRT, C. O Cent	2.40	2.70	2.90	V
21	B Output	V ₂₁	BRT, C. O Cent	2.40	2.70	2.90	V
22	V out	V ₂₂		-	-	-	-
23	NFB	V ₂₃	-	-	-	-	-
24	V. Ramp	V ₂₄		-	-	-	-
25	V SEPA	V ₂₅	-	5.80	6.30	6.80	V
26	H. V _{CC}	V ₂₆	-	-	9.00	-	V
27	SCL	V ₂₇	-	4.50	5.00	5.50	V
28	SDA	V ₂₈	-	4.50	5.00	5.50	V
29	X-RAY	V ₂₉	-	-	0.00	-	V
30	FBP Input	V ₃₀	-	-	-	-	-
31	Sync. Output	V ₃₁	-	-	-	-	-
32	H. Output	V ₃₂	-	-	-	-	-
33	H. AFC	V ₃₃	-	7.00	7.50	8.00	V
34	32f _H VCO	V ₃₄	-	5.50	6.00	6.50	V
35	D. GND	GND		-	0.00	-	V
36	ABL	V ₃₆	BRT, COL Cent	2.90	3.40	3.90	V
37	TV Input	V ₃₇		2.90	3.00	3.90	V
38	ACL	V ₃₈	BRT, COL Cent	2.90	3.40	3.90	V

PIN NO.	CHARACTERISTIC	SYMBOL	TEST CONDITION	MIN.	TYP.	MAX	UNIT
39	EXT. Video Input	V ₃₉	-	1.10	1.60	2.10	V
40	Black DET	V ₄₀	-	6.10	6.60	7.10	V
41	AV/SW Output	V ₄₁	-	1.80	2.30	2.80	V
42	DC Rest	V ₄₂	-	5.50	6.00	6.50	V
43	Y Input	V ₄₃	-	4.00	4.50	5.00	V
44	AFT	V ₄₄	-	2.00	2.50	3.00	V
45	Chroma Input	V ₄₅	-	1.60	1.85	2.10	V
46	V / C / D Vcc	V ₄₆	-	-	9.00	-	V
47	TV DET. Output	V ₄₇	-	4.70	5.20	5.70	V
48	SIF Vcc	V ₄₈	-	-	9.00	-	V
49	PIF Tank	V ₄₉	-	-	-	-	V
50	PIF Tank	V ₅₀	-	-	-	-	V
51	SIF GND	Vcc	-	-	0.00	-	V
52	Limiter Input	V ₅₂	-	-	0.00	0.50	V
53	Audio TV Input	V ₅₃	-	2.50	3.00	3.50	V
54	De-emphasis	V ₅₄	Pin4 GND	4.00	4.50	5.00	V
55	EXT. Audio Input	V ₅₅	-	2.50	3.00	3.50	V

Current Consumption

CHARACTERISTIC	SYMBOL	TEST CONDITION	MIN.	TYP.	MAX.	UNIT
IF Power Supply Current	I _{cci}	-	32.8	46	52.0	mA
V/C/D Power Supply Current	I _{ccv}	-	52.7	71	76.8	mA
H.Vcc Power Supply Current	I _{ccH}	-	10.7	14	18.4	mA
D.Vcc Power Supply Current	I _{ccd}	-	5.2	10	11.6	mA

AC CHARACTERISTICS (Unless Otherwise Specified, V_{CC} = 9V, T_a = 25°C)

PIF

CHARACTERISTIC	SYMBOL	TEST CONDITION	MIN	TYP	MAX	UNIT
Video Detected Output level	V ₀₁	Note 1	1.7	2.0	2.3	V _{p-p}
	V ₀₂		2.0	2.5	3.0	
Input Sensitivity	V _{IN MIN}	Note 2	-	42	-	dB _{μV}
	V _{IN MAX}		100	107	-	
Sync Tip Level	V _{SYNC}	Note 3	2.6	2.9	3.2	V
Output Level For No Input	V _{IF}	Note 4	4.8	5.2	5.6	V
Differential Gain	DG	Note 5	-	2	5	%
Differential Phase	DP		-	2	5	°
PIF Output Frequency Characteristic	f _C	Note 6	5	7	-	MHz
Carrier Wave Compression Ratio	CR	Note 7	50	55	-	dB
2nd Harmonics Compression Ratio	HR		50	55	-	
PIF Input Resistance	R _{iPIF}	Note 8	-	1.5	-	kΩ
PIF Input Capacitance	C _{iPIF}		-	3.8	-	pF
S/N	S/N	Note 9	52	55	-	dB
920kHz Beat	I ₉₂₀	Note 10	42	45	-	dB
IF AGC Range	RW _{AGC}	Note 11	61	65	69	dB
IF AGC Voltage	V _{5MEAN}	Note 12	4.2	4.5	4.8	V
	V _{5MAX}		7.4	7.6	-	
	V _{5MIN}		-	3.8	-	
RF AGC Voltage	V _{3MAX}	Note 13	7.7	8.2	-	V
	V _{3MIN}		-	0	0.5	
RF AGC Control Range	Δ _{GRFAGC}	Note 14	35	40	-	dB
AFT Center Voltage	V _{4CENT}	Note 15	2.2	2.5	2.8	V
AFT Voltage	V _{4MAX}	Note 16	4.4	4.8	-	V
	V _{4MIN}		-	0.2	0.5	
AFT Sensitivity	Δ _{AFT}	Note 17	-	40	-	kHz/V
AFT Output Resistance	RA _{FTOUT}	Note 18	40	50	60	kΩ
PIF VCO Control Sensitivity	Δ _{fVCO}	Note 19	2.0	2.5	-	MHz/V
PIF VCO Pull-in Range	f _{ph}	Note 20	1.0	1.5	-	MHz
	f _{pl}		1.0	1.5	-	
PIF VCO Control Range	Δ _{fPIFVCO}	Note 21	-	4.4	-	MHz

SIF

CHARACTERISTIC	SYMBOL	TEST CONDITION	MIN.	TYP.	MAX.	UNIT
Sound Output Level	VAAC	Note 22	400	500	600	mVrms
	VADC		-	4.5	-	V
Sound Distortion	VAUDIO	Note 23	-	0.3	1.0	%
AMR	AMR	Note 24	50	60	-	dB
Limiting Sensitivity	VLIM	Note 25	-	35	-	dB \neq V
Sound Output Frequency Characteristics	fAUDIOH	Note 26	-	130	-	kHz
	fAUDIOL		-	-130	-	
Sound Output Resistance	RSOUT	Note 27	24	30	36	k \neq \emptyset

ATT

ATT Gain	GATTMAXE	Note 28	-2.0	0.0	2.0	dB
	GATTMAXT		4.0	6.0	8.0	
	GATTMEAN		-16	-12	-9	
	GATTMIN		-99	-85	-	
DC Voltage Drift	V1VAR	Note 29	-	-	50	mV
	V1DC		3.2	3.7	4.2	V
Input Impedance	Ri53	Note 30	-	30	-	k \neq \emptyset
	Ri55		-	47	-	

Video

Input Impedance	Ri41	Note 31	100	-	-	k \neq \emptyset
Input Dynamic Range	Vdi41	Note 32	1.0	1.2	1.5	V
Video Total Gain	GY	Note 33	4.5	5.0	-	
Video Frequency Characteristic	f _y	Note 34	6.0	7.0	-	MHz
Maximum Output	Vdo1	Note 35	7.5	8.0	-	V
Blackexpansion Amp. Gain	GBAMP	Note 36	1.18	1.43	1.68	
Black Expansion Start Point	GBSTP		40	50	60	IRE
Dc Restoration	Tdc	Note 37	100	103	105	%
Sharpness Control Characteristics	GSHcent	Note 38	1	4	7	dB
	GSHmax		9	12	15	
	GSHmin		-	-18	-15	
Sharpness Delay Time	tSHDLY	Note 39	-	125	-	ns
Cntrast Control Characteristics	GCNcent	Note 40	4.5	6	7.5	dB
	GCNmin		22.5	24	28.5	
H. V - BLK Output Voltage	VBLK	Note 41	-	0.7	1.0	V
V-BLK Width	TvBLK	Note 42	-	3.5~24	-	H
fsc Trap Gain	GTRAP	Note 43	-	-28	-20	dB

OSD

CHARACTERISTIC	SYMBOL	TEST CONDITION	MIN.	TYP.	MAX.	UNIT
Osd Switching Voltage	VthOSD	Note 44	0.7	1.0	1.3	V
Osd Delay Time	tOSDDL	Note 45	-	15	30	ns
Osd Delay Time Difference	tOSDD		-	5	10	
Osd Rising Time	¥óR		-	15	30	
OSD Falling Time	¥óF		-	15	30	
Input Clamp Voltage	VOSDC	Note 46	4.4	4.9	5.4	V
OSD Gain	GOSD	Note 47	1.8	2.0	2.2	V
Input Dynamic Range	VdiOSD	Note 48	2.0	2.2	2.4	V

Cutoff Drive

Brightness Control Characteristics	VBRTmax	Note 49	3.6	4.0	4.3	V
	VBRTcen		2.4	2.7	3.0	
	VBRTmin		1.0	1.4	1.7	
Brightness Control Difference Between 3Axes	¥ÄVRGB	Note 50	-50	0	50	mV
Cutoff Control Characteristics	Vcutmax	Note 51	0.5	0.65	0.8	V
	Vcutcen		-	0.00	-	
	Vcutmin		-0.8	-0.65	-0.5	
Drive Control Characteristics	Gdrvmax	Note 52	3.75	4.25	4.75	dB
	Gdrvmin		-4.0	-3.5	-3.0	

Chroma

Input Dynamic Range	Vdi45	Note 53	0.95	1.5	1.7	V
ACC Characteristic	ea	Note 54	-23	-20	-17	dB
	eb		3	6	9	
	A		0.9	1.0	1.1	
Killer Point	EK	Note 55	-48	-46	-43	dB
VCXO Frequency Control Range	¥Äfvcxo	Note 56	¼ 50 0	¼ 60 0	-	Hz
VCXO Frequency Control Sensitivity	¥âvcxo	Note 57	-	1.0	-	Hz/mV
VCXO Pull-in Range	fvcxopl	Note 58	¼ 30 0	¼ 45 0	-	Hz
Demodulate Relative Gain	R / B	Note 59	0.80	0.84	0.90	°
	G / B		0.25	0.29	0.33	
Demodulate Relative Phase	R - B		101	108	115	
	G - B		236	243	250	
Carrier Wave Remain	ECR	Note 60	-	20	40	mVp-p
	ECB		-	20	40	
	ECG		-	20	40	

CHARACTERISTIC	SYMBOL	TEST CONDITION	MIN.	TYP.	MAX.	UNIT
Color Control Characteristic	VCLRmax	Note 61	3.9	4.1	4.3	Vp-p
	GCLRcen		4.5	6	7.5	dB
	GCLRmin		38	40	-	
Uni-color Control Characteristic	GUNcen	Note 62	4.5	6	7.5	dB
	GUNimin		22	24	26	
TINT Control Characteristic	ƳĒTNTcen	Note 63	-7	0	7	ƒ
	ƳĒ ƳĒTNT		Ƴ/4 3 5	Ƴ/4 4 5	Ƴ/4 55	
Video Chroma Delay Time	tv - C	Note 64	-30	0	30	ns

Deflection

Horizontal Free Run Freq.	fH	Note 65	-100	0	100	Hz
H. Out Pulse Duty	TH	Note 66	38	41	44	%
H. Out Voltage	VHL	Note 67	-	0.2	0.3	V
	VHH		2.5	3.0	3.5	
VCO Osc. Start Voltage	VOSCmin	Note 68	3.0	3.5	4.0	V
H. Out Start Voltage	VHST	Note 69	3.7	4.0	-	V
H. Frequency Control Range	ƳĒfH	Note 70	Ƴ/4 500	Ƴ/4 650	-	Hz
H. Freq. Control Sensitivity	ƳĒĤH	Note 71	-	500	-	Hz/V
H. Sync. Pull-in Range	ƳĒfHPUL	Note 72	Ƴ/4 450	Ƴ/4 500	-	Hz
H. Pull-in Stop Period	THSTP	Note 73	-	259 ~272	-	H
AFC-2 Control Range	TAFC2	Note 74	16	17	-	ƳĒ
Horizontal Position Adjustment	TPAFC2	Note 75	-	Ƴ/4 3	-	ƳĒ
X-RAY Protection Detection Voltage	VXDET	Note 76	3.35	3.5	3.65	V
X-RAY Protection Hold Voltage	VXHLD		3.9	4.2	4.5	
X-RAY Protection Hold Current	VXLD		80	100	120	ƳĒ
Vertical Free Run Freq.	fV	Note 77	-	295	-	H
V. Sync. Pull-in Range	TVST	Note 78	-	224	-	H
	TVEND		-	295	-	
V. Out Pulse Width	TV	Note 79	-	8	-	H
V. Ramp Amplitude Control	VVL	Note 80	2.2	2.4	-	V
	VVH		-	1.6	1.8	
H. Sync. Separation Level	Rsepa	Note 81	30	35	40	%
Forced V. Osc. (262.5H)	fV60	Note 82	-	60	-	Hz

SIGNAL FOR MEASUREMENT

ç Input Signal 1

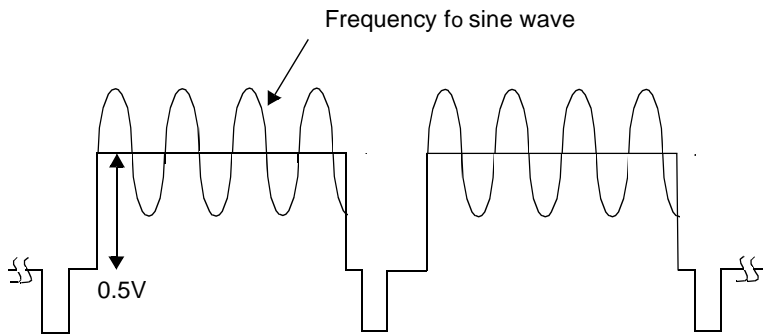

è Input Signal 2

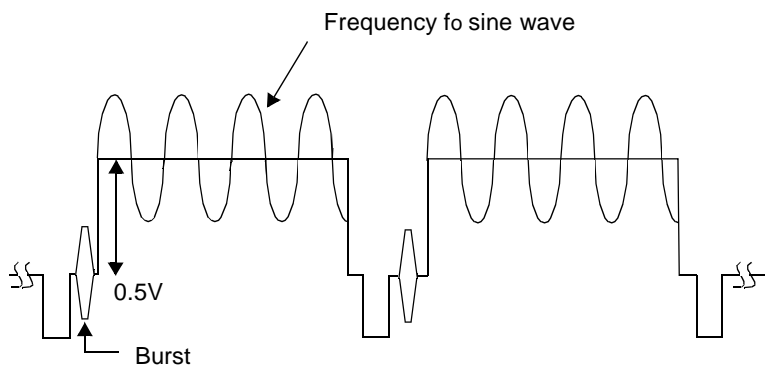



LittleDiode supplies new, hard to find or obsolete electronic components and semiconductors all over the world.

With over two million different components listed you are sure to find the part you need.

Feel free to visit us today at our online store:

LittleDiode.com

Looking forward to providing you with the best possible service.