

RGB ENCODER FOR PAL/NTSC

The KA2198BD is a monolithic circuit designed for RGB encoder of video system. This device provides encoding system of PAL and NTSC video signal. The KA2198BD contains matrix of R-Y/B-Y, modulator, pulse generator, regulator, built in BPF of chroma and delay line of luminance, Y/C output using S-VHS system. It is suitable for video equipment.

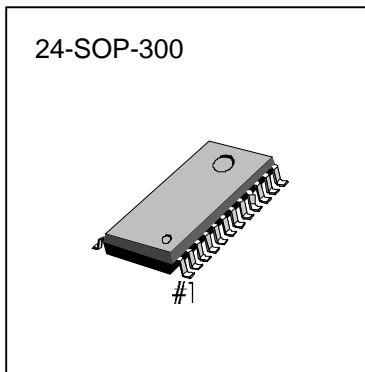

FUNCTIONS

- Regulator
- Mixer of R-Y, B-Y
- Modulator
- Pulse generator (ECL circuit)
- Audio buffer
- Clamp circuit
- Y-TRAP filter
- BPF & D.L circuit
- Y/C output driver

ORDERING INFORMATION

Device	Package	Operating Temperature
KA2198BD	24-SOP-300	-20°C~+65°C

FEATURES

- Lower operating voltage : $V_{CC} = 5V$
- Stabilized bias condition in regulator
- Available PAL/NTSC system
- Included 75 ohm driver (RGB output, composite video output, Y/C output)
- External fsc (color sub-carrier)
- Include BPF & delay line
- Audio buffer circuit
- R-Y, B-Y modulator
- Available S-VHS
- High frequency response of luminance

BLOCK DIAGRAM

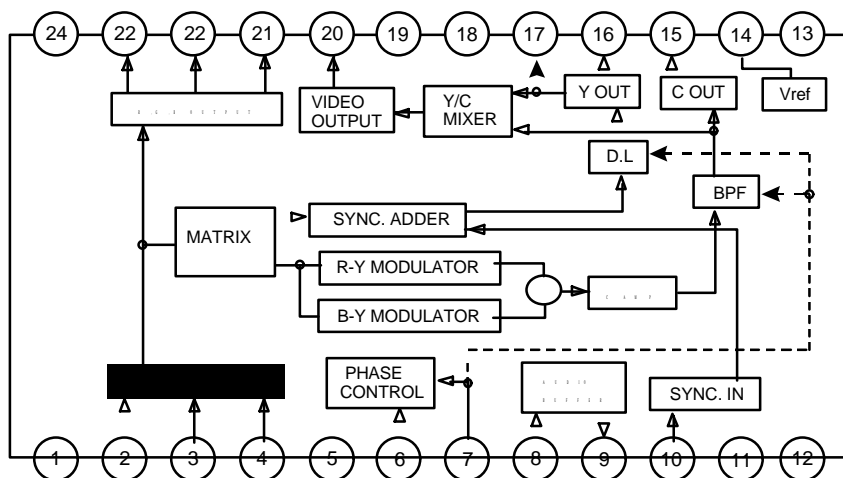

PIN CONFIGURATION

Pin No.	DESCRIPTION	Pin No.	DESCRIPTION
1	GND1	13	N.C
2	R INPUT	14	2V REGULATOR
3	G INPUT	15	C.OUT
4	B INPUT	16	Y OUT
5	N.C	17	Y-TRAP FILTER
6	fsc INPUT	18	N.C
7	NTSC/PAL SW	19	VCC2
8	AUDIO IN	20	COMPOSITE VIDEO OUTPUT
9	AUDIO OUT	21	B OUTPUT
10	COMPOSITE SYNC. IN	22	G OUTPUT
11	N.C	23	R OUTPUT
12	VCC1	24	GND2

(note) V_{CC1} , GND1 : except output stage
 V_{CC2} , GND2 : output stage supply voltage

ABSOLUTE MAXIMUM RATINGS ($T_A=25^\circ\text{C}$)

Characteristics	Symbol	Value	Unit
MAX Supply Voltage	V_{CCMAX}	10	V
Power Dissipation	P_D	1250	mW
Operating Temperature	T_{OPR}	-20~+70	$^\circ\text{C}$
Storage Temperature	T_{STG}	-55~+150	$^\circ\text{C}$

ELECTRICAL CHARACTERISTICS ($T_A=25^\circ\text{C}$, $V_{CC}=5\text{V}$)

Characteristics	Symbol	Test Conditions	Min	Typ	Max	Unit
Supply Current 1	I_{CC1}	No signal input	25	39	49	mA
Supply Current 2	I_{CC2}		5.0	11	16	mA
R Output Voltage	V_{OR}	R,G,B input signals $V_{in}=1.0 V_{P-P}$, $f=200\text{KHz}$	0.64	0.71	0.78	V_{P-P}
G Output Voltage	V_{OG}		0.64	0.71	0.78	V_{P-P}
B Output Voltage	V_{OB}		0.64	0.71	0.78	V_{P-P}
R Frequency Response	R_{FC}	R,G,B input signals $V_{in}=1.0 V_{P-P}$, $f=200\text{KHz}$ (-3dB point)	5.0	-	-	MHz
G Frequency Response	G_{FC}		5.0	-	-	MHz
B Frequency Response	B_{FC}		5.0	-	-	MHz
Y Frequency Response	Y_{FCN}	Y OUT (-3dB point)	6.0	-	-	MHz
R 100% Y Level Ratio(CVBS)	V_{YR1}	R,G,B input signals $V_{in}=1.0 V_{P-P}$ (100% R,G,B / 100% Y)	0.19	0.21	0.25	-
G 100% Y Level Ratio(CVBS)	V_{YG1}		0.38	0.42	0.48	-
B 100% Y Level Ratio(CVBS)	V_{YB1}		0.07	0.08	0.09	-

Characteristics	Symbol	Test Conditions	Min	Typ	Max	Unit
100% Y Level (CVBS)	V _{YW1}		0.64	0.71	0.82	V _{P-P}
Sync. Level 1 (CVBS)	V _{SNC1}		0.26	0.29	0.33	V _{P-P}
R 100% Y Level Ratio (Y OUT)	V _{YR2}	R,G,B input signal V _{in} =1.0V _{P-P} (100% R,G,B / 100% Y)	0.19	0.21	0.25	-
G 100% Y Level Ratio (Y OUT)	V _{YG2}		0.38	0.42	0.48	-
B 100% Y Level Ratio (Y OUT)	V _{YB2}		0.07	0.08	0.09	-
100% Y Level (Y OUT)	V _{YW2}		0.64	0.71	0.82	V _{P-P}
Sync. Level 1 (Y OUT)	V _{SNC2}		0.26	0.29	0.33	V _{P-P}
Audio Buffer Gain	G _a	Audio Input 100KHz, 1V _{P-P}	-1.0	1.0	1.1	dB
Audio Frequency Response	F _a		30	-	-	KHz
Audio Distortion	THD		-	-	1.0	%
NTSC mode						
R Chroma Ratio 1 (CVBS)	R/B1	fsc input 3.58MHz, 400mV _{P-P} (check CVBS out)	2.70	3.15	3.50	-
G Chroma Ratio 1 (CVBS)	G/B1		2.55	2.95	3.25	-
B Chroma Ratio 1 (CVBS)	B/B1		1.90	2.24	2.47	-
Burst level 1 (CVBS)	Vob1		0.20	0.29	0.34	V _{P-P}
R Chroma Ratio 2 (C OUT)	R/B2	fsc input 3.58MHz, 400mV _{P-P} (check C out)	2.70	3.15	3.50	-
G Chroma Ratio 2 (C OUT)	G/B2		2.55	2.95	3.25	-
B Chroma Ratio 2 (C OUT)	B/B2		1.90	2.24	2.47	-
Burst level 2 (C OUT)	Vob2		0.20	0.29	0.34	V _{P-P}
R Phase (CVBS)	SR _N	fsc input 3.58MHz, 400mV _{P-P} (check CVBS out)	94	104	114	deg
G Phase (CVBS)	SG _N		231	241	251	deg
B Phase (CVBS)	SB _N		337	347	357	deg
Burst Width	T _{WN}		2.5	2.75	3.6	usec
Burst Position	T _{PN}		0.45	0.5	0.75	usec
Carrier Leakage	CL	CVBS out, Y out	-	-	0.03	V _{P-P}
PAL mode						
R Chroma Ratio 3 (CVBS)	R/B3	fsc input 3.58MHz, 400mV _{P-P} (check CVBS out)	2.70	3.15	3.50	-
G Chroma Ratio 3 (CVBS)	G/B3		2.55	2.95	3.25	-
B Chroma Ratio 3 (CVBS)	B/B3		1.90	2.24	2.47	-
Burst level 3 (CVBS)	Vob3		0.20	0.29	0.34	V _{P-P}
R Chroma Ratio 4 (C OUT)	R/B4	fsc input 3.58MHz, 400mV _{P-P} (check C out)	2.80	3.15	3.50	-
G Chroma Ratio 4 (C OUT)	G/B4		2.65	2.95	3.25	-
B Chroma Ratio 4 (C OUT)	B/B4		2.01	2.24	2.47	-
Burst level 4 (CVBS)	Vob4		0.20	0.29	0.34	V _{P-P}
R Phase (CVBS)	SR _P	fsc input 3.58MHz, 400mV _{P-P} (check CVBS out)	94	104	114	deg
G Phase (CVBS)	SG _P		231	241	251	deg
B Phase (CVBS)	SB _P		337	347	357	deg
Burst Width	T _{WP}		2.0	2.25	2.5	usec
Burst Position	T _{PP}		0.35	0.45	0.55	usec
PAL Burst Phase 1	P1	CVBS out, Y out	125	135	145	deg
PAL Burst Phase 2	P2		215	225	235	deg
Y Frequency Response	Y _{FCP}	Y output (-3dB point)	6.0	-	-	MHz

TEST WAVEFORM

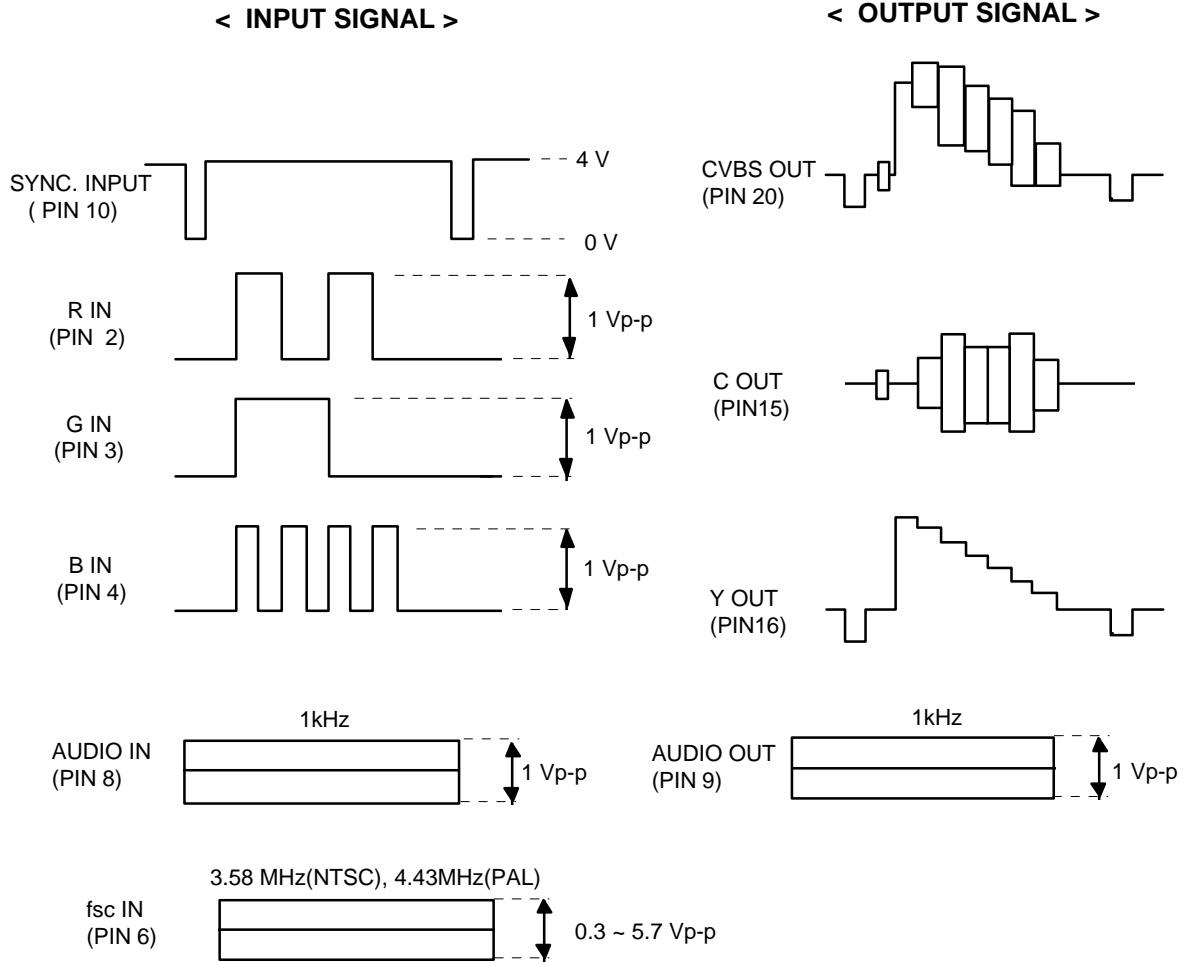

APPLICATION CIRCUIT

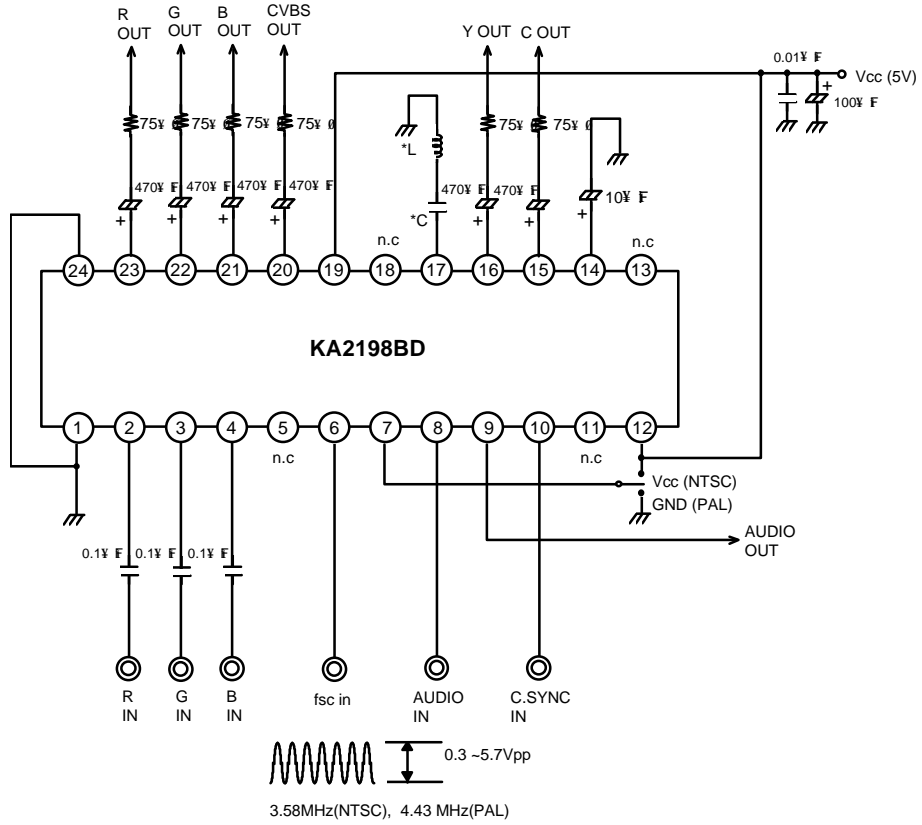

SYSTEM	Fo(MHz)	★L(uH)	★C(pF)
NTST	3.57	100	20
PAL	4.43	82	15

KA2198BD

RGB ENCODER FOR PAL/NTSC

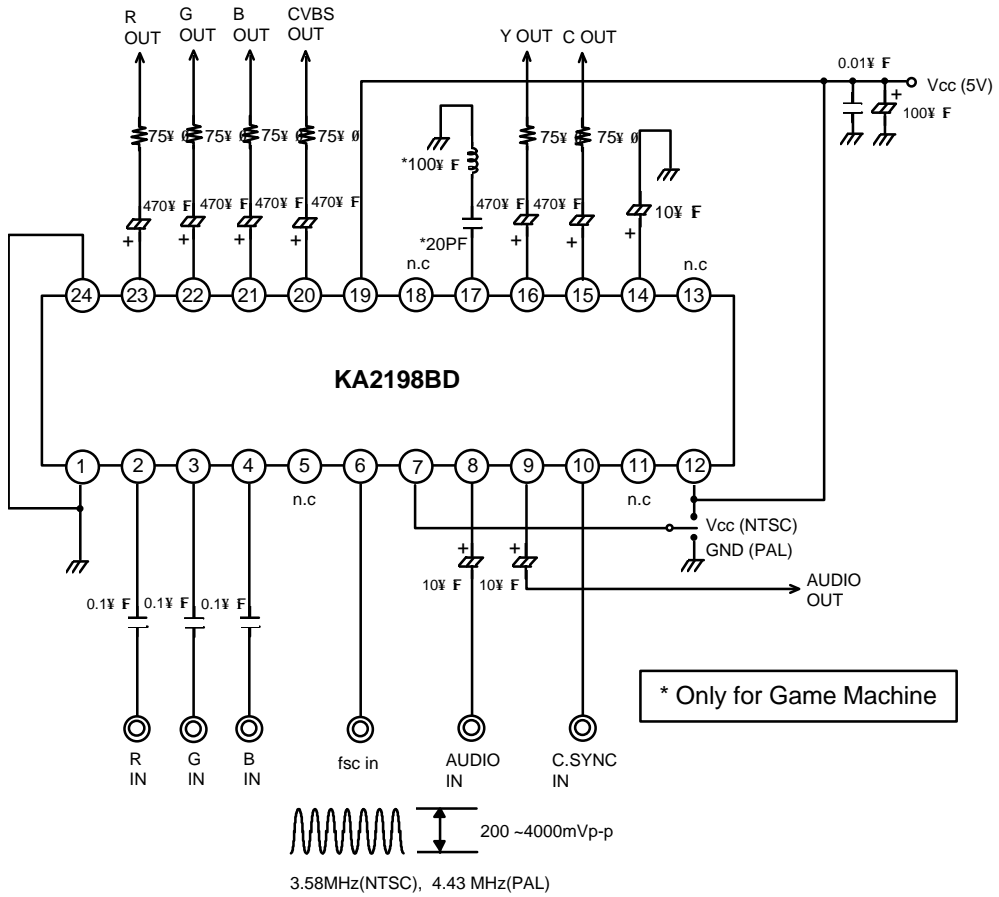



LittleDiode supplies new, hard to find or obsolete electronic components and semiconductors all over the world.

With over two million different components listed you are sure to find the part you need.

Feel free to visit us today at our online store:

LittleDiode.com

Looking forward to providing you with the best possible service.