

DUAL PRE-POWER AMPLIFIER AND DC MOTOR SPEED CONTROLLER

The KA22135 is a monolithic integrated circuit designed for use in low voltage and low power applications. It has all functions including a dual audio pre-power amplifier and motor speed controller in a single chip. It is suitable for portable tape recorders, head phone cassette tape recorders or battery-powered radios.

FEATURES

- Low current consumption in a operating voltage range.
- Wide operating supply voltage range; $V_{CC} = 2V \sim 7.5V$.
- Only a few components to build headphone cassette tape recorders.
- Dual audio pre-power amplifier and motor speed controller in a single chip.
- Reduced input and output coupling capacitors because of 1/2 V_{CC} AMP adaption on chip as AC GND.

22 SDIP

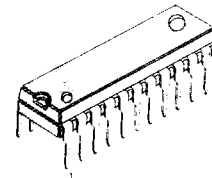

ORDERING INFORMATION

Device	Package	Operating Temperature
KA22135	22 SDIP	-20°C ~ +70°C

BLOCK DIAGRAM

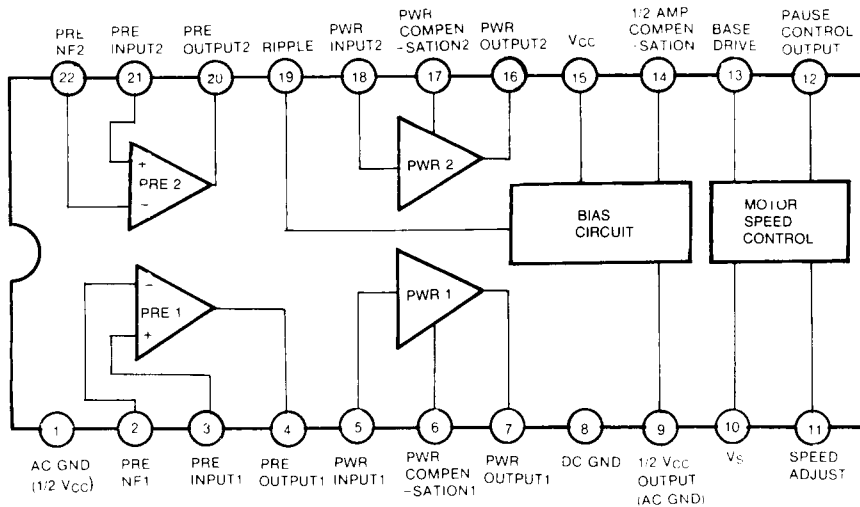

Fig. 1

ABSOLUTE MAXIMUM RATINGS (Ta = 25°C)

Characteristic	Symbol	Value	Unit
Supply Voltage	V _{CC}	10	V
Power Dissipation	P _D	600	mW
Operating Temperature	T _{OPR}	- 20 ~ + 70	°C
Storage Temperature	T _{STG}	- 40 ~ + 125	°C

ELECTRICAL CHARACTERISTICS (Ta = 25°C)

Characteristic	Symbol	Test Conditions	Min	Typ	Max	Unit
Quiescent Circuit Current	I _{CCQ}	V _{CC} = 3V, V _I = 0, I _M = 0mA		15	25	mA

PRE AMPLIFIER SECTION

(Ta = 25°C, V_{CC} = 3V, f = 1KHz, R_{L1} = 10KΩ, unless otherwise specified)

Characteristic	Symbol	Test Conditions	Min	Typ	Max	Unit
Open Loop Voltage Gain	G _{VO}	V _O = - 10dBm, R _L = ∞		72		dB
Closed Loop Voltage Gain	G _{VC}	V _O = - 10dBm	40	42	44	dB
Output Voltage	V _O	THD = 1%	0.35	0.6		V
Total Harmonic Distortion	THD	V _O = 400mV		0.05	0.5	%
Output Noise Voltage	V _{NO}	V _I = 0, R _G = 2.2KΩ BW(- 3dB) = 30Hz ~ 20KHz		70	300	μV
Input Resistance	R _I	V _O = - 10dBm	18	22		KΩ
Cross Talk	CT	R _G = 2.2KΩ, V _O = - 10dBm	45	62		dB

POWER AMPLIFIER SECTION

(Ta = 25°C, V_{CC} = 3V, f = 1KHz, R_{L2} = 32Ω, unless otherwise specified)

Characteristic	Symbol	Test Conditions	Min	Typ	Max	Unit
Closed Loop Voltage Gain	G _{VC}	P _O = 5mW	26	28	30	dB
Output Power	P _O	THD = 10%	20	28		mW
Total Harmonic Distortion	THD	P _O = 5mW		0.2	2.0	%
Output Noise Voltage	V _{NO}	R _G = 10KΩ, BW(- 3dB) = 30Hz ~ 20KHz		0.25	1.0	mV
Input Resistance	R _I	P _O = 5mW	10	20		KΩ
Cross Talk	CT	P _O = 5mW, R _G = 10KΩ	35	50		dB

MOTOR SPEED CONTROLLER SECTION

(Ta = 25°C, V_{CC} = 3V, I_M = 10μA, unless otherwise specified)

Characteristic	Symbol	Test Condition	Min	Typ	Max	Unit
Base Driving Current	I _B		10	18		mA
Reference Voltage	V _{REF}		0.22	0.26	0.30	V
Reference Voltage Regulation 1	ΔV _{REF1}	V _{CC} = 2.0 ~ 6.5V		0.05		%/V
Reference Voltage Regulation 2	ΔV _{REF2}	I _M = 25 ~ 200mA		0.1		%/mA
Reference Voltage Regulation 3	ΔV _{REF3}	Ta = -10 ~ +60°C		0.01		%/°C
Current Coefficient	K	$K = \frac{V_L - V_{R2}}{V_{R1} + V_{R2}}$	3.7	4	4.3	
Current Coefficient Regulation 1	ΔK ₁	V _{CC} = 2.0 ~ 6.5V		0.05		%/V
Current Coefficient Regulation 2	ΔK ₂	I _M = 25 ~ 200mA		0.1		%/mA
Current Coefficient Regulation 3	ΔK ₃	Ta = -10 ~ +60°C		0.1		%/°C

TEST CIRCUIT

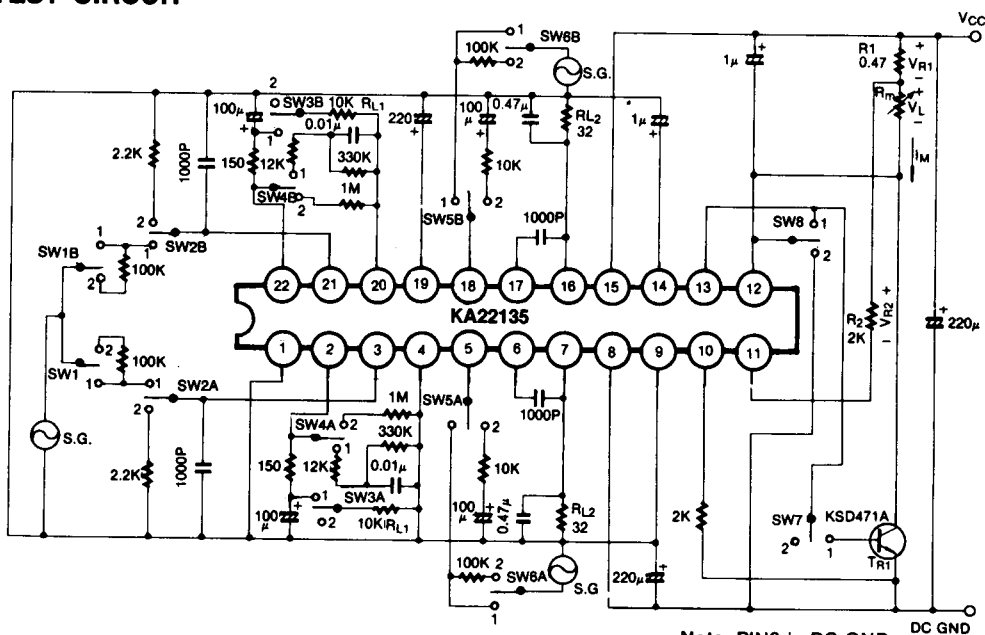

Fig. 2

Note: PIN8 is DC GND
PIN9 is AC GND

TEST METHOD

TEST ITEM		SWITCH	SW1 A/B	SW2 A/B	SW3 A/B	SW4 A/B	SW5 A/B	SW6 A/B	SW7	SW8
I _{CCQ}			1	2	1	1	2	1	1	2
Pre-Amplifier	CH1 G _{VO}		"	1	2	2	"	"	"	"
	CH1 G _{VC}		"	"	1	1	"	"	"	"
	CH1 V _O		"	"	"	"	"	"	"	"
	CH1 THD		"	"	"	"	"	"	"	"
	CH1 V _{NO}		"	2	"	"	"	"	"	"
	CH1 R _i		2	1	"	"	"	"	"	"
	CH2 G _{VO}		1	2	"	"	"	"	"	"
	CH2 G _{VC}		"	"	"	"	"	"	"	"
	CH2 V _O		"	"	"	"	"	"	"	"
	CH2 THD		"	"	"	"	"	"	"	"
	CH2 V _{NO}		"	"	"	"	"	"	"	"
	CH2 R _i		"	"	"	"	"	"	"	"
	CT ₁ (2→1)		"	"	"	"	"	"	"	"
	CT ₂ (1→2)		"	1	"	"	"	"	"	"
Power-Amplifier	CH1 G _V		"	2	"	"	"	"	"	"
	CH1 P _O		"	"	"	"	"	"	"	"
	CH1 THD		"	"	"	"	"	"	"	"
	CH1 V _{NO}		"	"	"	"	2	"	"	"
	CH1 R _i		"	"	"	"	1	2	"	"
	CH2 G _V		"	"	"	"	2	1	"	"
	CH2 P _O		"	"	"	"	"	"	"	"
	CH2 THD		"	"	"	"	"	"	"	"
	CH2 V _{NO}		"	"	"	"	"	"	"	"
	CH2 R _i		"	"	"	"	"	"	"	"
	CT ₁ (2→1)		"	"	"	"	"	"	"	"
CT ₂ (1→2)		"	"	"	"	1	"	"	"	
M.S.C	I _B		"	"	"	"	2	"	2	1
	V _{REF}		"	"	"	"	"	"	1	"
	ΔV _{REF}		"	"	"	"	"	"	"	"
	K		"	"	"	"	"	"	"	"
	ΔK		"	"	"	"	"	"	"	"

APPLICATION CIRCUIT

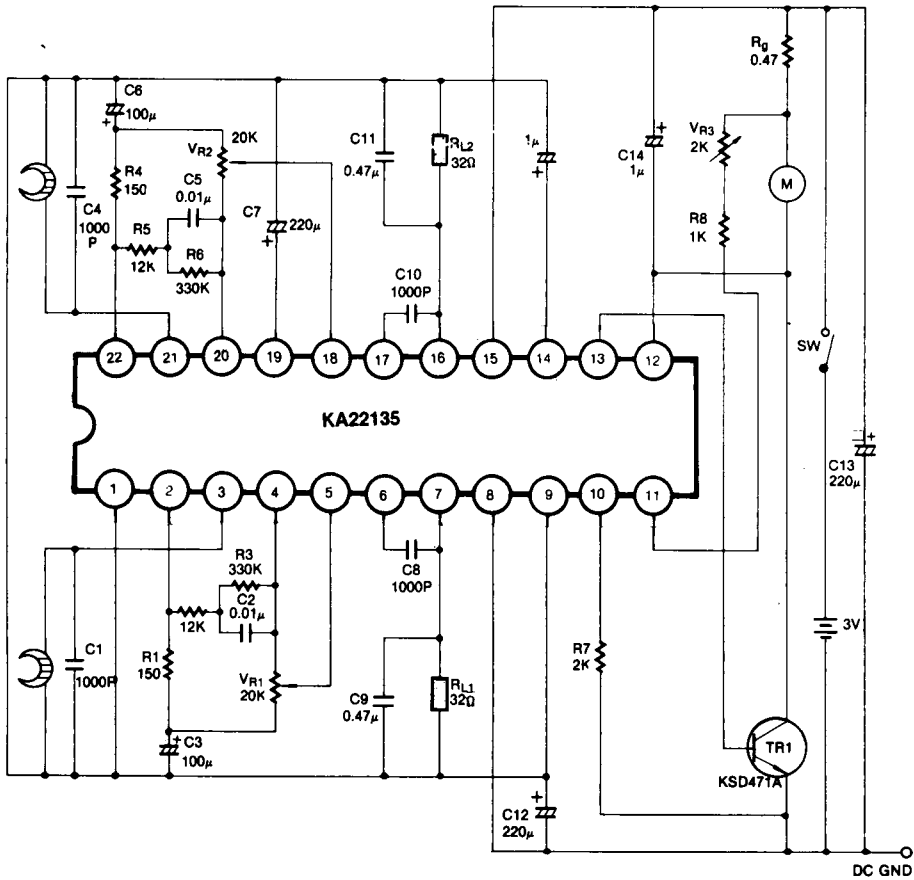

Fig. 3

- Note: 1. For C12, use a capacitor of Low TANδ
 2. For C9 and C11, use solid state capacitors with better characteristics at low temperature
 3. Locate C7 just around the emitter TR1, KSD471A.



LittleDiode supplies new, hard to find or obsolete electronic components and semiconductors all over the world.

With over two million different components listed you are sure to find the part you need.

Feel free to visit us today at our online store:

LittleDiode.com

Looking forward to providing you with the best possible service.