

INTROCUCTION

The KA22425D is a monolithic integrated circuit designed for radio cassette tape recorders, clock radios and headphone radios.

FUNCTIONS

- AM/FM RF AMP
- AM AGO Control
- Audio Power AMP
- DC Volume
- FM Quadrature DET
- AUDIO MUTE
- Local OSC
- FM AFO Control
- Tuning Indicator
- AM/FM IF AMP
- AM DET

FEATURES

- Built-in AM/FM Switching Circuit
- Wide operating supply voltage: $V_{CC} = 2V \sim 7.5V$
- Low current consumption ($V_{CC} = 3V$)
 - FM: $I_{CCQ} = 5.3mA$ (Typ)
 - AM: $I_{CCQ} = 3.4mA$ (Typ)
- High power audio amplifier: 0.5W(Typ) at $V_{CC} = 6V$,
- $R_L = 8\Omega$, THD = 10 %

ORDERING INFORMATION

Device	Package	Operating Temperature
KA22425D	28-SOP-375	-20°C ~ +70°C

28-SOP-375

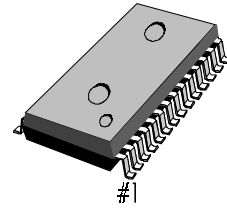

BLOCK DIAGRAM

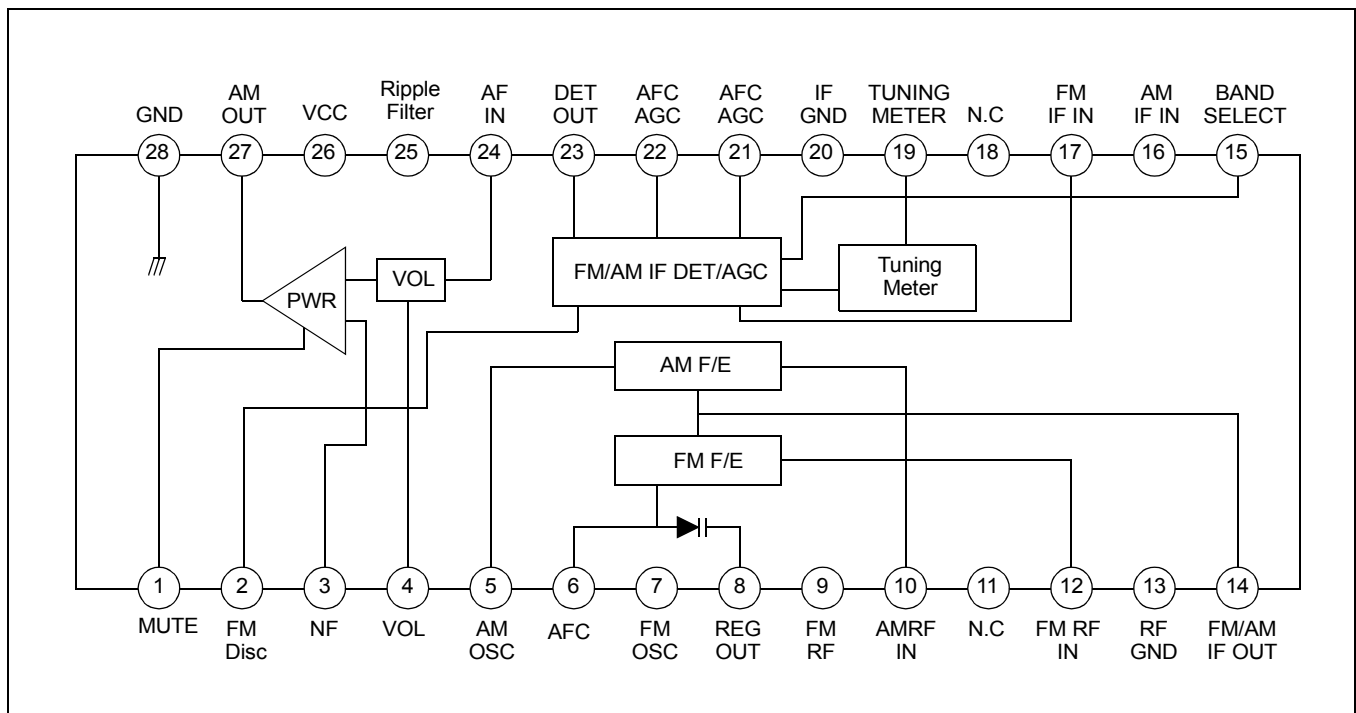

Figure 1.

ABSOLUTE MAXIMUM RATINGS (Ta = 25°C)

Characteristic	Symbol	Value	Unit
Supply Voltage	V _{CC}	9	V
Power Dissipation	P _D	1000	mW
Operating Temperature	T _{OPR}	-20 ~ +70	°C
Storage Temperature	T _{STG}	-40 ~ +125	°C

ELECTRICAL CHARACTERISTICS

(V_{CC} = 6V, Ta = 25°C, FM; Δf = 22.5kHz, fm = 1kHz, AM; 30% Mod, unless otherwise specified)

	Characteristic	Symbol	Test Conditions	Min.	Typ.	Max.	Unit
FM	Quiescent Circuit Current	I _{CCQ} (1)	V _i = 0	–	7.0	14.0	mA
	F/E Voltage Gain	G _V (1)	V _i (1) = 40dBμ, f _c = 100MHz, f = 0	32	39	46	dB
	Detect Output Gain	V _O (1)	V _i (3) = 90dBμ, f _i = 10.7MHz	–26	–20	–14	dBm
	IF-3 dB Sensitivity	V _{I(LIM)}	V _O (V _I 3) = 90dBμ –3dB, f _i = 10.7MHz	–	24	32	dBμ
	Total Harmonic Distortion	THD ₁	V _i (3) = 90dBμ, f _i = 10.7MHz(Δf = 75kHz)	–	0.3	2.0	%
	Meter Drive Current	I _M (1)	V _i (3) = 60dBμ, f _i = 10.7MHz	1.8	3.5	7.0	mA
AM	Quiescent Circuit Current	I _{CCQ} (2)	V _i = 0	–	3.5	10.0	mA
	F/E Voltage Gain	G _V (2)	V _i (2) = 60dBμ, f _c = 1660kHz, m = 0%	15	22	29	dB
	IF Voltage Gain	G _V (3)	V _O (3) = –34dBm, f _i = 455kHz	14	20	27	dBμ
	AM Detect Output Voltage	V _O (2)	V _i (3) = 85dBμ, f _i = 455kHz	–26	–20	–14	dBm
	Total Harmonic Distortion	THD ₂	V _i (2) = 95dBμ, f _c = 1660kHz, V _{CC} =7.8V	–	0.6	2.0	%
	Meter Drive Current	I _M (2)	V _i (3) = 85dBμ, f _i = 455kHz	1.3	3.0	7.0	mA
AF	Closed Loop Voltage Gain	G _V (4)	V _O (4) = 0dBm, f = 1kHz	27	31.5	36	dB
	Total Harmonic Distortion	THD ₃	P _O = 50mW, f = 1kHz	–	0.3	2.5	%
	Output Power	P _O	R _L = 8Ω, THD = 10%, f = 1kHz	0.4	0.5	–	W
	Mute Level	M _L	P _O = mW, V _i (4) = 30dBm 1kHz, V _i (3) = FF	8	15	22	dB

APPLICATION CIRCUIT

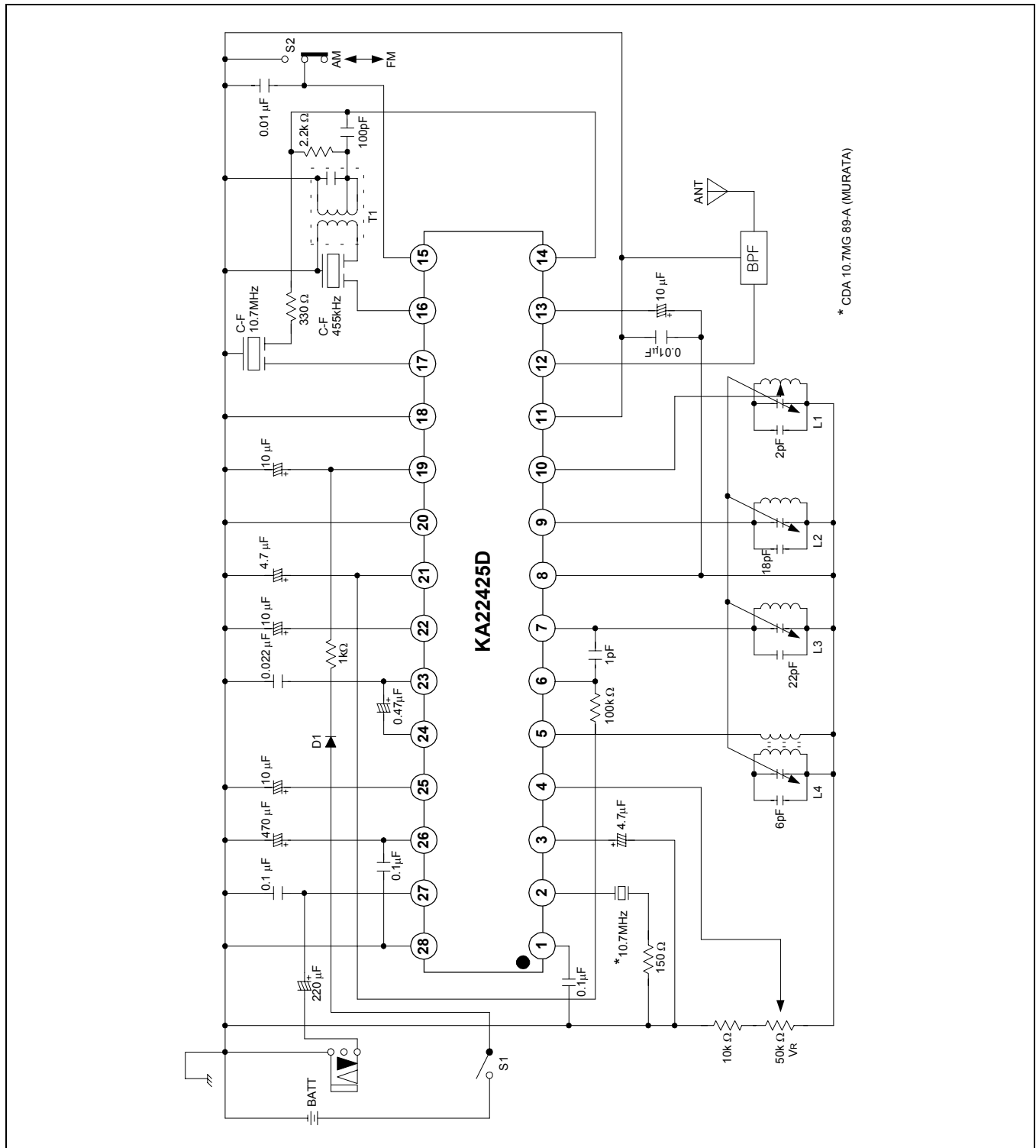

Figure 2.



LittleDiode supplies new, hard to find or obsolete electronic components and semiconductors all over the world.

With over two million different components listed you are sure to find the part you need.

Feel free to visit us today at our online store:

LittleDiode.com

Looking forward to providing you with the best possible service.