

AM/FM IF SYSTEM

The KA2243 is a monolithic integrated circuit developed for radio cassette tape recorders which include AM/FM IF amplifier and detector.

FUNCTIONS

- AM Section:
 - IF amplifier with AGC detector.
 - Signal meter driver circuit.
 - Voltage regulator for RF external circuit.
- FM Section:
 - IF amplifier.
 - Quadrature detector.
 - Post amplifier.
 - Signal meter driver circuit.

FEATURES

- Suitable for radio cassettes and home stereos.
- Wide operating supply voltage range: $V_{CC} = 3V \sim 14V$.
- Low quiescent circuit current.
- AM section.
 - Simplified input circuit IFT (Ceramic filter type).
 - RF AGC available.
- FM section.
 - High limiting sensitivity ($33dB\mu$, Typ).
 - Low residual noise ($45dB$ at $V_i = -10dB\mu$).
 - Small side peak or detuned output voltage.

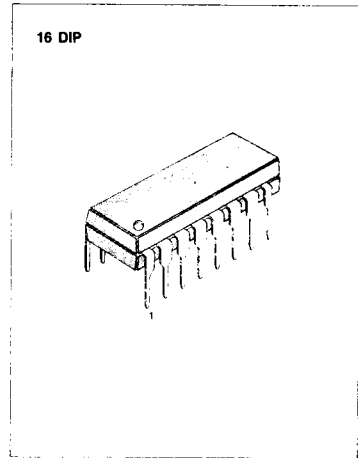

ORDERING INFORMATION

Device	Package	Operating Temperature
KA2243	16 DIP	-20°C ~ +70°C

BLOCK DIAGRAM

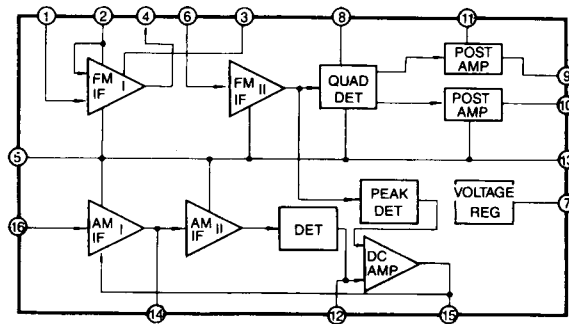

ABSOLUTE MAXIMUM RATINGS ($T_a = 25^\circ\text{C}$)

Characteristic	Symbol	Value	Unit
Supply Voltage	V_{CC}	16	V
Power Dissipation	P_D	600	mW
Operating Temperature	T_{OPR}	-20 ~ +70	$^\circ\text{C}$
Storage Temperature	T_{STG}	-40 ~ +125	$^\circ\text{C}$

ELECTRICAL CHARACTERISTICS

($T_a = 25^\circ\text{C}$, $V_{CC} = 5.5\text{V}$, unless otherwise specified)

Characteristic	Symbol	Test Conditions	Min	Typ	Max	Unit
----------------	--------	-----------------	-----	-----	-----	------

FM Section ($f = 10.7\text{MHz}$, $f_m = 1\text{KHz}$, $\Delta f = \pm 75\text{KHz}$)

Quiescent Circuit Current	I_{CCQ}	$V_i = 0$	7	11	16.5	mA
-3dB Limiting Sensitivity	$V_{i(LIM)}$	$V_o (V_i = 100\text{dB}\mu) - 3\text{dB}$		33	38	$\text{dB}\mu$
Detector Output Voltage	$V_o (DET)$	$V_i = 100\text{dB}\mu$	180	245	310	mV
Total Harmonic Distortion	THD	$V_i = 100\text{dB}\mu$		0.3	1.0	%
AM Rejection Ratio	AMR	$V_i = 100\text{dB}\mu$	50	60		dB
Signal to Noise Ratio	S/N	$V_i = 100\text{dB}\mu$	72	83		dB
Signal Meter Output	V_M	$V_i = 100\text{dB}\mu$	1.05	1.5	2.05	V
Residual Noise	V_N	$V_o (AF) (V_i = 100\text{dB}\mu)$ $V_o (AF) (V_i = -10\text{dB}\mu)$		45		dB
Muting Attenuation	ATT_{MUTE}	$V_i = 37\text{dB}\mu$, Mute SW on		35		dB

AM Section ($f = 455\text{KHz}$, $f_m = 1\text{KHz}$, 30% Mod)

Quiescent Circuit Current	I_{CCQ}	$V_i = 0$		8		mA
Maximum Sensitivity	S_{MAX}	$V_o (AF) = 10\text{mV}$		29		$\text{dB}\mu$
Detector Output Voltage	V_o	$V_i = 74\text{dB}\mu$	45	65	85	mV
Total Harmonic Distortion	THD	$V_i = 74\text{dB}\mu$		0.3	2.0	%
		$V_i = 100\text{dB}\mu$		0.7	3.5	%
Signal to Noise Ratio	S/N	$V_i = 74\text{dB}\mu$	45	55		$\text{dB}\mu$
Signal Meter Output	V_M	$V_i = 100\text{dB}\mu$	1.2	1.4	1.6	V
Input Impedance (Pin 16)	Z_i	Pin 16 0.8-0.9V _{DC}	1.45	2.12	2.8	K Ω

TEST CIRCUIT

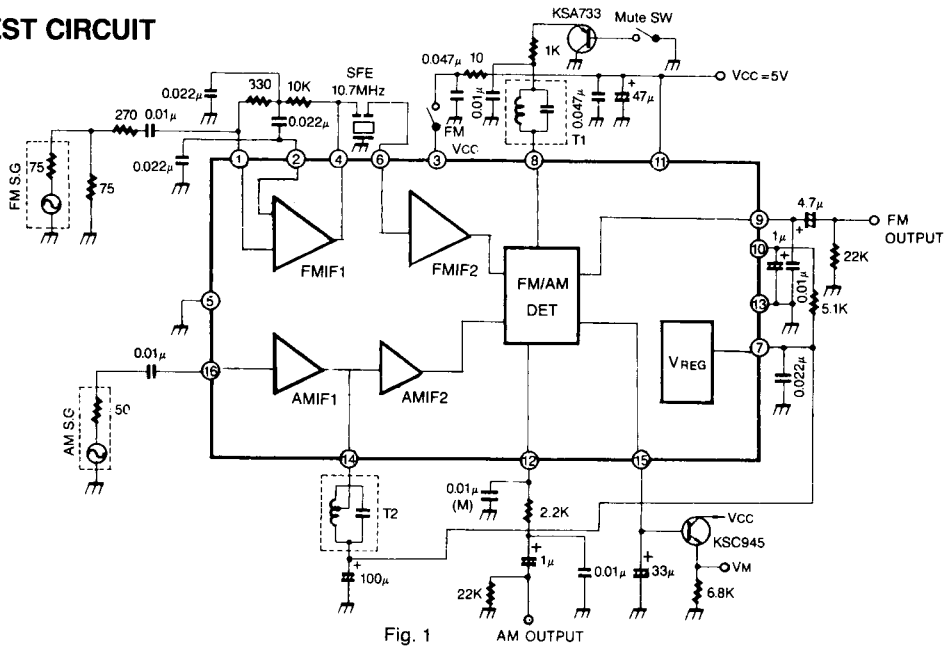
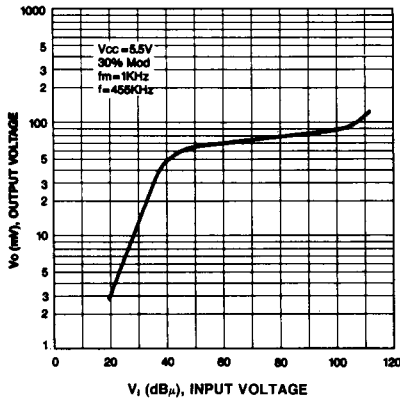

Fig. 1

(AM Section)

OUTPUT VOLTAGE-INPUT VOLTAGE



TOTAL HARMONIC DISTORTION-INPUT VOLTAGE

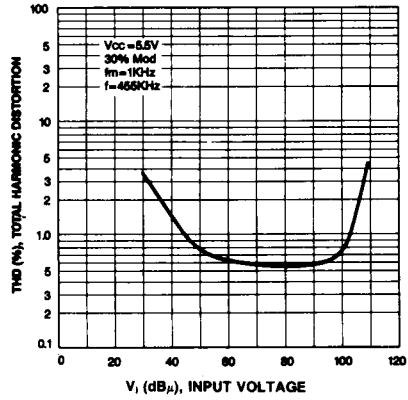

SIGNAL TO NOISE RATIO-INPUT VOLTAGE

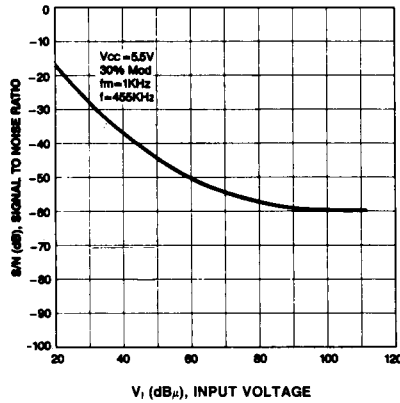

SIGNAL METER OUTPUT VOLTAGE-INPUT VOLTAGE

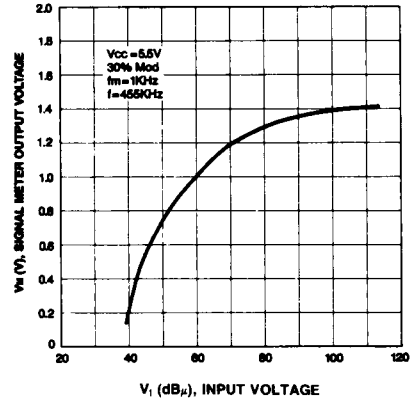

OUTPUT VOLTAGE-SUPPLY VOLTAGE

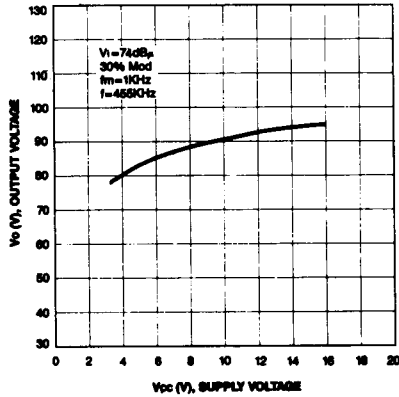

TOTAL HARMONIC DISTORTION-SUPPLY VOLTAGE

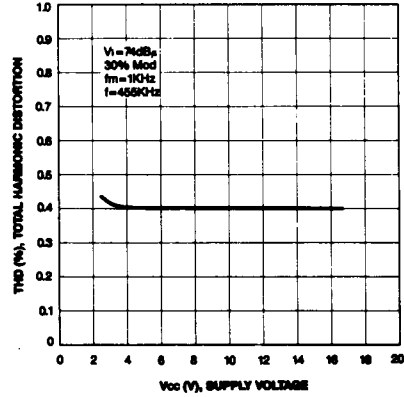

QUIESCENT CIRCUIT CURRENT-SUPPLY VOLTAGE

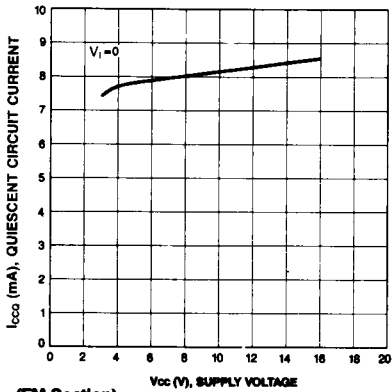

OUTPUT VOLTAGE — MODULATION
TOTAL HARMONIC DISTORTION

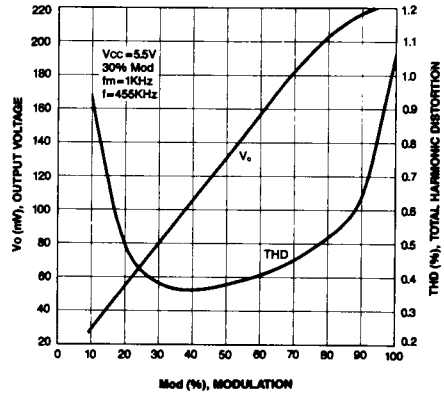

(FM Section)

OUTPUT VOLTAGE-INPUT VOLTAGE

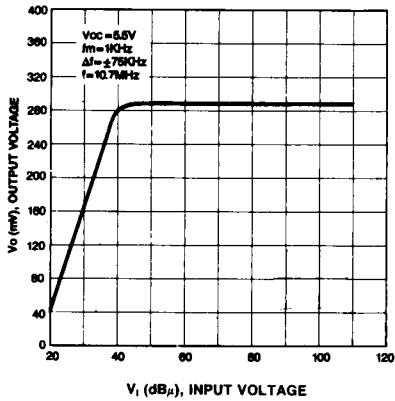

TOTAL HARMONIC DISTORTION-INPUT VOLTAGE

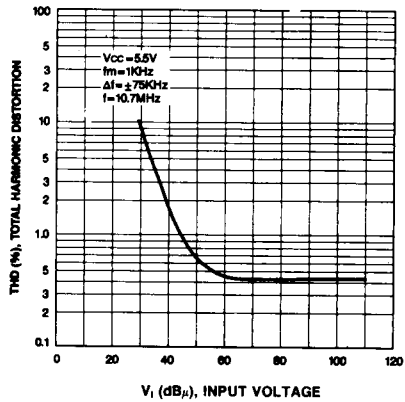

SIGNAL TO NOISE RATIO-INPUT VOLTAGE

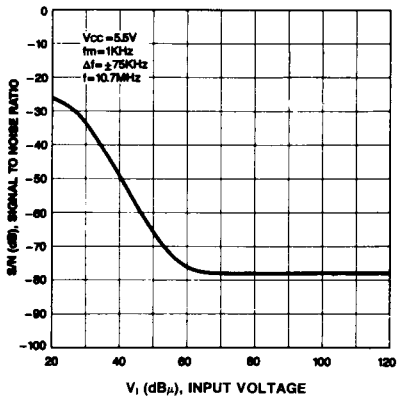

AM REJECTION RATIO-INPUT VOLTAGE

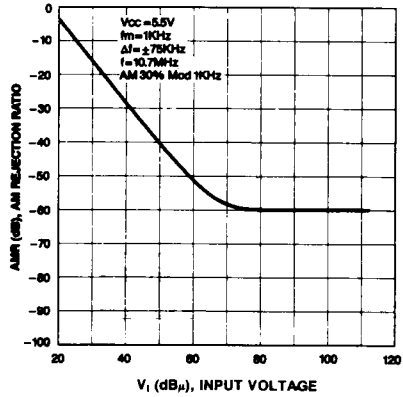

SIGNAL METER OUTPUT VOLTAGE-INPUT VOLTAGE

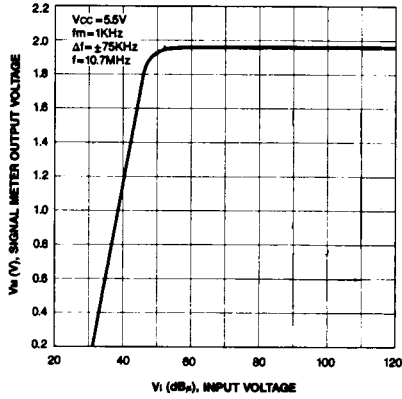

OUTPUT VOLTAGE-SUPPLY VOLTAGE

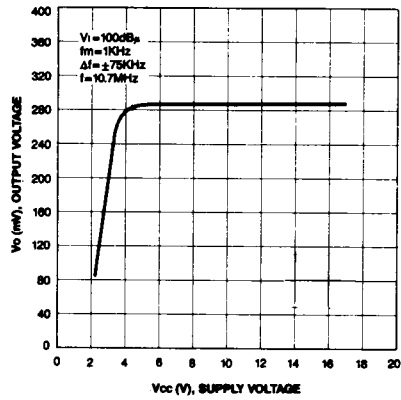

TOTAL HARMONIC DISTORTION-SUPPLY VOLTAGE

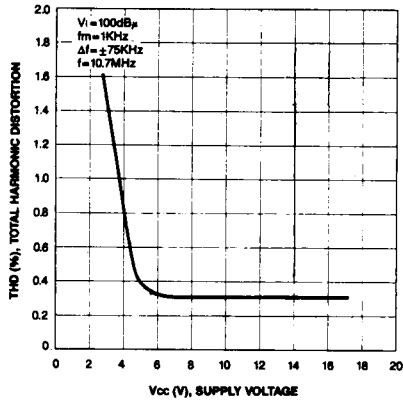

OUTPUT VOLTAGE-INPUT FREQUENCY

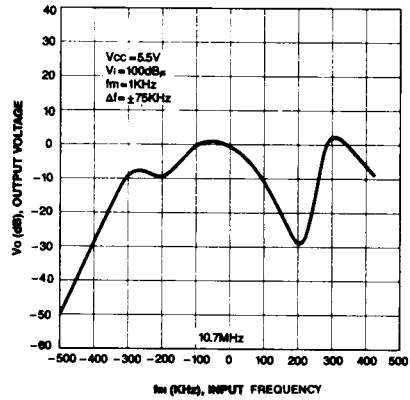

QUIESCENT CIRCUIT CURRENT-SUPPLY VOLTAGE

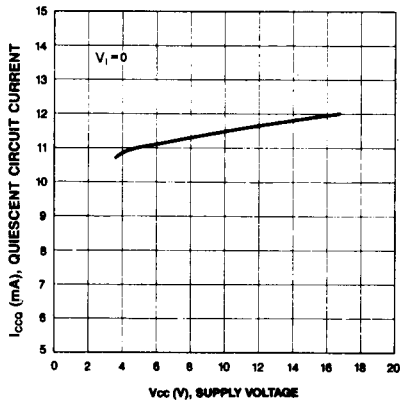

APPLICATION CIRCUIT

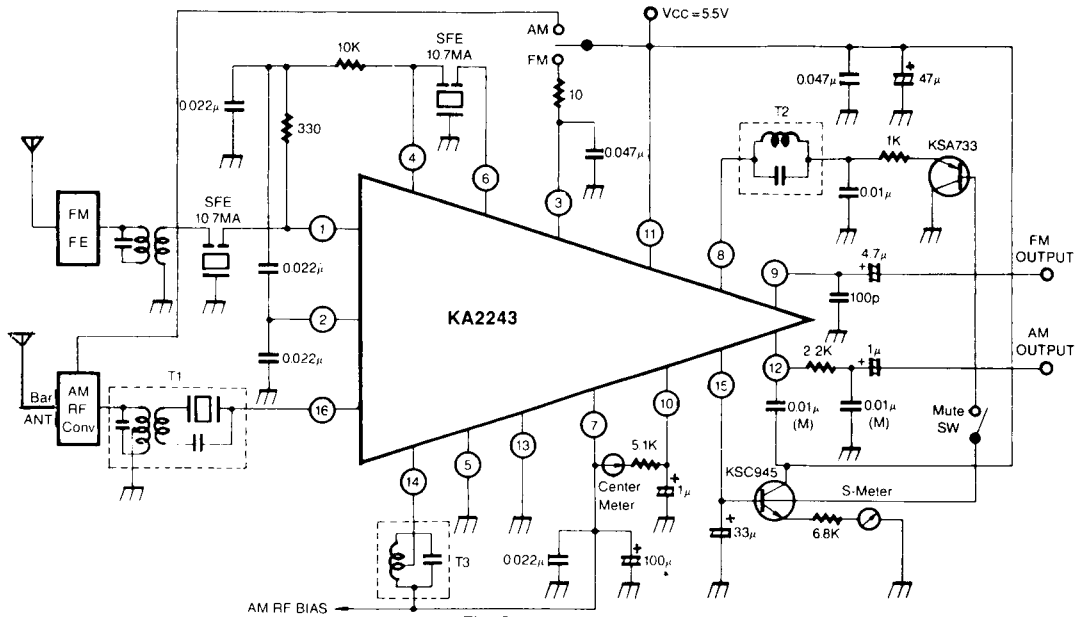
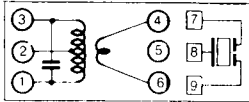

Fig. 2

COIL SPECIFICATION

1. T1



C _o (pF)	f (KHz)	Q _o (%)	TURNS		
			4-6	3-2	2-1
180	455	105	6	93	55

Seoul Jupa
SJ-015-552
0.06mmφ UEW

2. T2

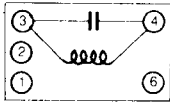

C _o (pF)	f (MHz)	Q _o (%)	TURNS		
			3-4		
82	10.7	65	9		

Seoul Jupa
SJ-59JG-043
0.07mmφ UEW

3. T3

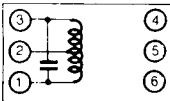

C _o (pF)	f (KHz)	Q _o (%)	TURNS	
			1-2	2-3
180	455	120	51	92

Seoul Jupa
SJ-015-521
0.07mmφ UEW



LittleDiode supplies new, hard to find or obsolete electronic components and semiconductors all over the world.

With over two million different components listed you are sure to find the part you need.

Feel free to visit us today at our online store:

LittleDiode.com

Looking forward to providing you with the best possible service.