

KA2418B/28

TONE RINGER WITH BRIDGE DIODE

INTRODUCTION

The KA2418B/28 is a monolithic integrated circuit telephone tone ringer with bridge diode, when coupled with an appropriate transducer, it replaces the electromechanical bell. This device is designed for use with either a piezo transducer or an inexpensive transformer coupled speaker to produce a pleasing tone composed of a high frequency (f_{H1} , f_{H2}) alternating with a low frequency (f_s) resulting in a warble frequency. The supply voltage is obtained from the AC ring signal and the circuit is designed so that noise on the line or variation of the ringing signal can not affect correct operation of the device.

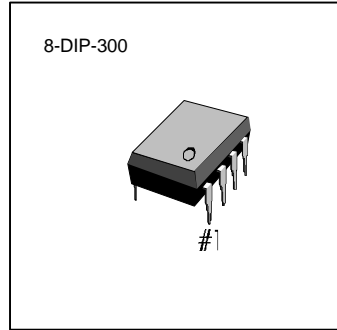

FEATURES

- Built-in full wave bridge diode rectifier
- Low current consumption, in order to allow the parallel operation of the 4 devices
- Few external components
- Tone and adjustable switching frequencies by external components
- High noise immunity due to built-in voltage to current hysteresis
- Adjustable activation voltage
- Internal zener diodes to protect against over voltages
- Adjustable ringer impedance with external components.

ORDERING INFORMATION

Device	Package	Operating Temperature
KA2418B	8-DIP-300	- 20°C ~ + 70°C
KA2428		

APPLICATIONS

- Electronic telephone ringers
- Extension ringers

BLOCK DIAGRAM

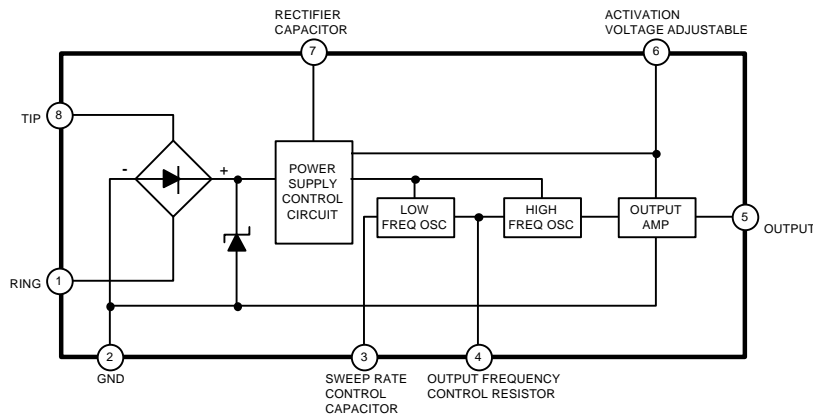

Fig. 1

ABSOLUTE MAXIMUM RATINGS

Characteristic	Symbol	Value	Unit
Calling Voltage (f = 50Hz) Continuous	V_C	120	Vrms
Calling Voltage (f = 50Hz) 5 Sec ON/10 Sec OFF	$V_{C(ON-OFF)}$	200	Vrms
Supply Current	I_{CC}	22	mA
Operating Temperature	T_{ORR}	-20 ~ +70	°C
Storage and Junction Temperature	T_{STG}	-65 ~ +150	°C

Absolute maximum ratings are those values beyond which permanent damage to the device may occur. These are stress ratings only and functional operation of the device at or beyond them is not implied. Long exposure to these conditions may affect device reliability.

DC ELECTRICAL CHARACTERISTICS ($T_a = 25^\circ\text{C}$)

Characteristic	Symbol	Test Conditions	Min	Typ	Max	Unit
Operating Voltage	V_{CC}	-	-	-	26	V
Current Consumption without Lode	I_{CC}	$V_S = 8.8$ to 26V	-	1.5	1.8	mA
Activation Voltage	V_{ON}	-	12.2	-	13	V
Activation Voltage Range	V_{ONR}	$R_A = 1K\Omega$	8	-	10	V
Sustaining Voltage	V_{SUS}	-	8	-	8.8	V
Differential Resistance in off Condition	$R_{D(OFF)}$	-	6.4	-	-	$K\Omega$
Output Voltage Swing	$V_{O(P-P)}$	-	-	V_{CC-3}	-	V
Short Circuit Current	I_{SC}	$V_S = 26V$	-	35	-	mA

AC ELECTRICAL CHARACTERISTICS ($T_a = 25^\circ\text{C}$)

Characteristic	Symbol	Test Conditions	Min	Typ	Max	Unit
Output Frequencies (KA2418B)	f_{H1}	$V_{CC} = 26V, R_1 = 14K\Omega$	-	2300	-	Hz
	f_{H2}	$V_{CC} = 0V$		1700	-	Hz
		$V_{CC} = 6V$				
Output Frequencies (KA2428)	f_{H1}	$V_{CC} = 26V, R_1 = 14K\Omega$	-	1900	-	Hz
	f_{H2}	$V_{CC} = 0V$		1300	-	Hz
		$V_{CC} = 6V$				
f_{H1} Range	f_{H1R}	$R_1 = 27K\Omega$ to $1.7K\Omega$	0.1	-	15	KHz
Sweep Frequency	f_S	$R_1 = 14K\Omega, C_1 = 100nF$	-	10	-	Hz

APPLICATION CIRCUIT

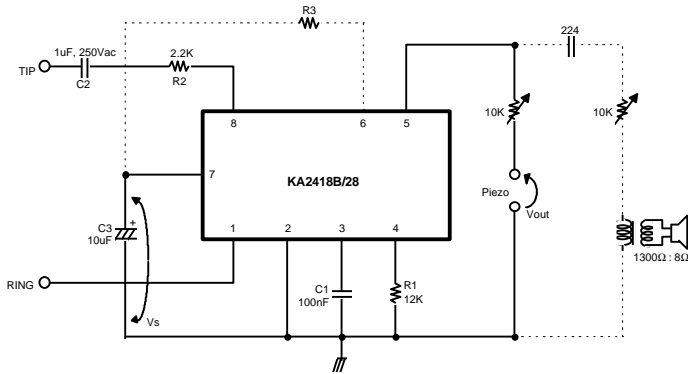

$$f_1 = \frac{3.22 \times 10^4}{R1(K)} \quad F_2 = \frac{5}{7} \cdot f_1 \quad f_s = \frac{1000}{C1(nF)}$$

Fig. 2

DEVICE / FUNCTION	KA2418B	KA2428B
f_1	$\frac{3.22 \times 10^4}{R1 (K)}$	$\frac{2.66 \times 10^4}{R1 (K)}$
$f_{H1} (R1 = 14K\Omega)$	2300 + 300 (Hz)	1900 + 100 (Hz)
$f_{H2} (R1 = 14K\Omega)$	1700 + 300 (Hz)	1300 + 100 (Hz)



LittleDiode supplies new, hard to find or obsolete electronic components and semiconductors all over the world.

With over two million different components listed you are sure to find the part you need.

Feel free to visit us today at our online store:

LittleDiode.com

Looking forward to providing you with the best possible service.