

MARCH. 1998

DATA SHEET

KA2504



I²C BUS CONTROLLED R/G/B VIDEO AMPLIFIER

The KA2504 is very high frequency video amplifier system with I²C BUS control used in Monitors.

It contains 3 matched R/G/B video Amplifiers and provides flexible interfacing to the I²C BUS controlled adjustment systems.

FUNCTIONS

- R/G/B Video Amplifier
- I²C BUS Control
- Contrast Control
- Brightness Control
- Cut-Off Brightness Control
- R/G/B SUB Contrast/Cut Off Control
- Blank/Clamp Gate
- Auto beam current limitation (ABL) is possible with external pin.
- The KA2504 includes white balance adjustment that is effective on brightness (by Cut-Off control for each channel).

FEATURES

- 3-Channel matched R/G/B Video Amplifiers
- I²C BUS control items
 - Contrast control for the 3 channels
 - Brightness control for the 3 channels
 - SUB Contrast control for each channel
 - Cut-Off control for each channel
 - Cut-Off Brightness control for the 3 channels
 - Switch Registers for SBLK and Cut-Off Offset Current
- Built-in ABL (Automatic Beam Limitation)
- Built-in Video output Brightness clamp
- 3-Channel R/G/B Video Amplifier 85 MHz @f-3 dB
- Contrast Control Range: -38 dB
- SUB Contrast Control Range: -11 dB
- Capable of 7 Vpp Output Swing

24-DIP-300

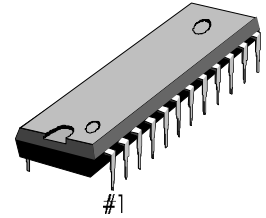

ORDERING INFORMATION

Device	Package	Operating Temperature
KA2504	24-DIP-300	-20 °C ~ 75 °

BLOCK DIAGRAM

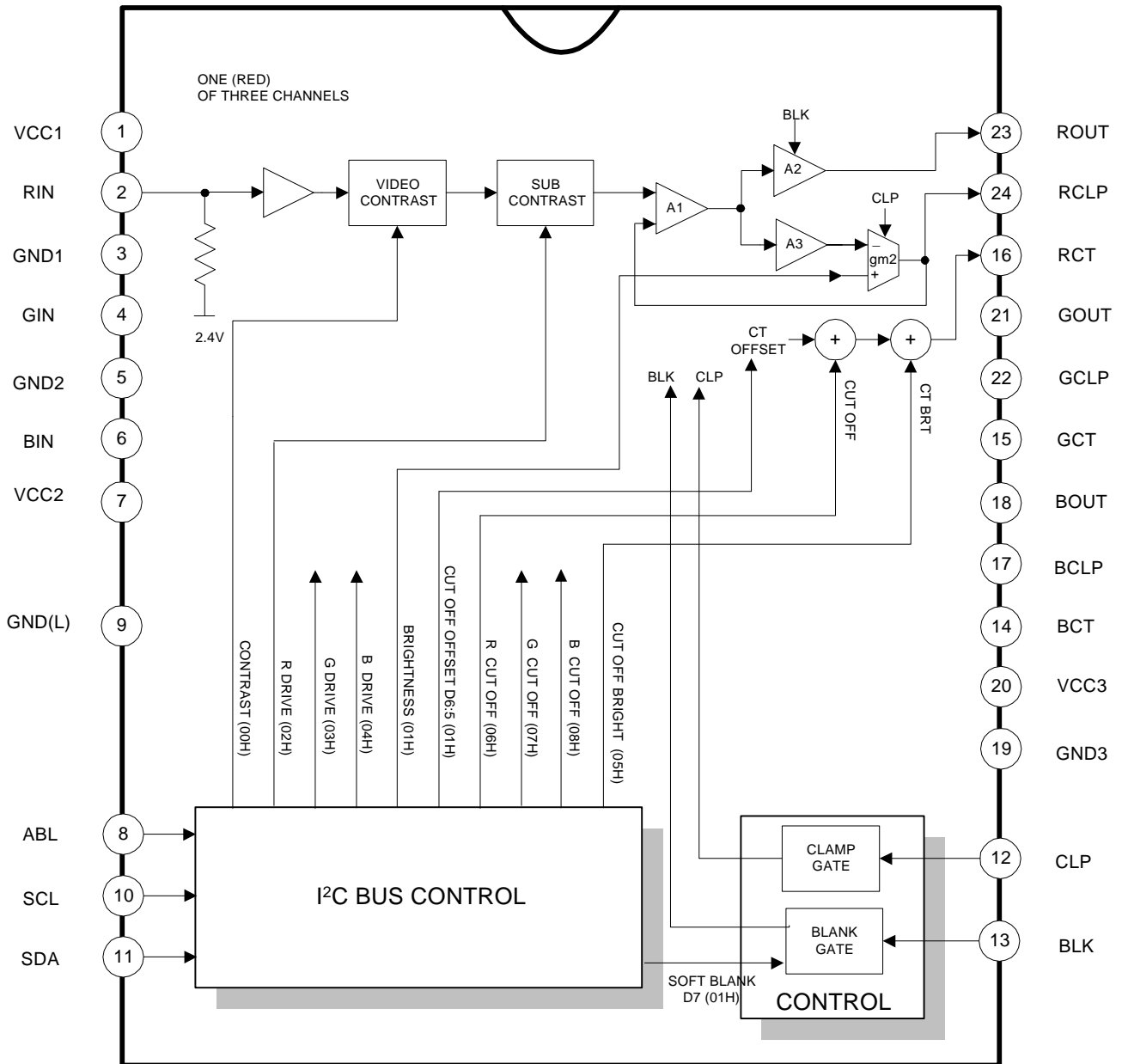

PIN CONFIGURATION

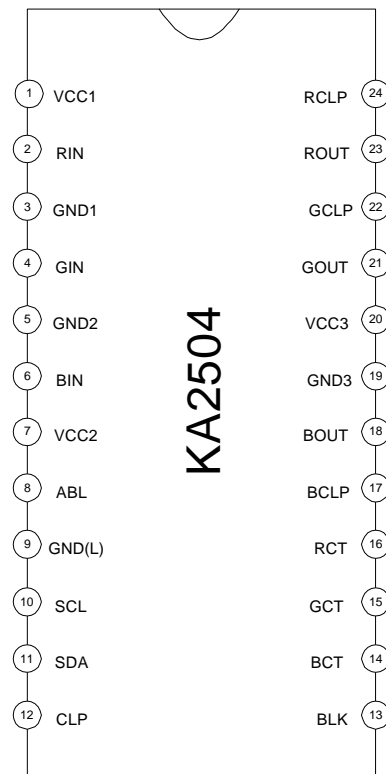

Table 1. Pin Configuration

NO	Symbol	I/O	Configuration	NO	Symbol	I/O	Configuration
1	V _{CC1}	-	Normal Power Supply	13	BLK	I	Blank Gate Input
2	RIN	I	Red Video Input	14	BCT	I	Blue Cut off ctrl
3	GND1	-	Normal Ground	15	GCT	I	Green Cut off ctrl
4	GIN	I	Green Video Input	16	RCT	I	Red Cut off ctrl
5	GND2	-	Normal Ground	17	BCLP	-	Blue Clamp Cap
6	BIN	I	Blue Video Input	18	BOUT	O	Blue Video Output
7	V _{CC2}	-	Normal Power Supply	19	GND3	-	Drive Power Ground
8	ABL	I	Automatic Beam Limit	20	V _{CC3}	-	Drive Power Supply
9	GND (L)	-	Logic Ground	21	GOUT	O	Green Video Output
10	SCL	I/O	Serial Clock	22	GCLP	-	Green Clamp Cap
11	SDA	I/O	Serial Data	23	ROUT	O	Red Video Output
12	CLP	I	Clamp Gate Input	24	RCLP	-	Red Clamp Cap

PIN DESCRIPTION

Table 2. Pin Description

Pin No	Pin Name	Schematic	Description
1	V _{CC1}	-	Normal V _{CC}
2	Red Video Input (RIN)		Video Input (Maximum 0.7 V _{pp})
4	Green Video Input (GIN)		
8	Blue Video Input (BIN)		
3	GND1	-	Normal Ground
5	GND2	-	Normal Ground
7	V _{CC2}	-	Logic V _{CC}
8	ABL		Auto Beam Limitation (Control Range: 0.5 ~ 4.5 V)
9	GND (L)	-	Logic Ground

Table 2. Pin Description (Continued)

Pin No	Pin Name	Schematic	Description
10	Serial Clock Input (SCL)		SCL, SDA for I ² C Bus Control
11	Serial Data Input (SDA)		
12	Clamp Gate Input (CLP)		Clamp Gate Input: TTL Level Active Low Clamp Gate Min. Duty f: 34 kHz duty: 0.3 μs
13	Blank Gate Input (BLK)		Blank Gate Input: TTL Level Active Low
14	Blue Cut-Off (BCT)		Cut-Off Control Output $I_{cut-off} = I_{ct} + I_{ctbrt} + I_{cs1} + I_{cs2}$ $I_{ct} : 0 \sim 540\mu A$ $I_{ctbrt} : 0 \sim 160\mu A$ $I_{cs1} : 80\mu A$ $I_{cs2} : 160\mu A$
15	Green Cut-Off (GCT)		
16	Red Cut-Off (RCT)		

Table 2. Pin Description (Continued)

Pin No	Pin Name	Schematic	Description
17	Blue Clamp Cap (BCLP)		Clamp Cap for Brightness (During Clamp Gate Low)
22	Green Clamp Cap (GCLP)		
24	Red Clamp Cap (RCLP)		
18	Blue Video Output (BOUT)		Video Out
21	Green Video Output (GOUT)		
23	Red Video Output (ROUT)		
19	GND3	-	Normal Ground
20	V _{CC3}	-	Drive V _{CC}

ABSOLUTE MAXIMUM RATINGS

NO	Item	Symbol	Value	Unit
1	Normal, Logic, Driver Power Supply	V _{CC} 1, 2, 3	13.2	V
2	Maximum Power Dissipation	PD _{max}	1.5	W

THERMAL CHARACTERISTICS

NO	Item	Symbol	Value	Unit
1	Storage Temperature	T _{stg}	-65 ~ 150	°C
2	Operating Temperature	T _{opr}	-20 ~ 75	°C
3	Thermal Resistance (Junction ambient)	θ _{ja}	60.0	°C/W
4	Junction Temperature	T _j	150.0	°C

ESD PARAMETER

NO	Item	Symbol	Value	Unit
1	Human Body Model (C = 100pF, R = 1.5kΩ)	HBM	2000	V
2	Machine Model (C = 200pF, R = 0)	MM	300	V
3	Charge Device Model	CDM	800	V

I²C BUS ELECTRICAL CHARACTERISTICS

Symbol	Description	Min	Typ	Max	Unit
V _{inH}	High Level Input Voltage	3.0	-	-	V
V _{inL}	Low Level Input Voltage	-	-	1.5	V
I _{inH}	High Level Input Current	-	-	1.0	μA
I _{inL}	Low Level Input Current	-	-	-10	μA
f _{SCL}	SCL Clock frequency	-	-	200	kHz

ELECTRICAL CHARACTERISTICS

DC Electrical Characteristics

(T_{amb} = 25 °C, V_{CC} = 12 V, V_{DD} = 12 V)

Table 3. DC Electrical Characteristics

No	Parameter	Symbol	Value			Unit
			Min	Typ	Max	
1	Supply Current	I _{CC}	60	80	100	mA
2	Maxium Supply Curent	I _{CC} max	70	90	110	mA
3	R Input Bias Voltage	V _{Rb}	2.2	2.4	2.6	V
4	G Input Bias Voltage	V _{Gb}	2.2	2.4	2.6	V
5	B Input Bias Voltage	V _{Bb}	2.2	2.4	2.6	V
6	R Clamp Gate Low Input Voltage	V _{12LR}	0.8	1.5	-	V
7	G Clamp Gate Low Input Voltage	V _{12LG}	0.8	1.5	-	V
8	B Clamp Gate Low Input Voltage	V _{12LB}	0.8	1.5	-	V
9	R Clamp Gate High Input Voltage	V _{12HR}	-	1.5	2.0	V
10	G Clmap Gate High Input Voltage	V _{12HG}	-	1.5	2.0	V
11	B Clamp Gate High Input Voltage	V _{12HB}	-	1.5	2.0	V
12	Clamp Gate Low Input Current	I _{12L}	-5.0	-2.0	-	μA
13	Clamp Gate High Input Current	I _{12H}	-	0.01	1.0	μA
14	R Output Clamp Cap Charge Current	I _{clampR+}	0.45	0.75	1.50	mA
15	G Output Clamp Cap Charge Current	I _{clampG+}	0.45	0.75	1.50	mA
16	B Output Clamp Cap Charge Current	I _{clampB+}	0.45	0.75	1.50	mA
17	R Output Clamp Cap Discharge Current	I _{clampR-}	-1.50	-0.75	-0.45	mA
18	G Output Clamp Cap Discharge Current	I _{clampG-}	-1.50	-0.75	-0.45	mA
19	B Output Clamp Cap Discharge Current	I _{clampB-}	-1.50	-0.75	-0.45	mA
20	R Blank Gate Low Input Voltage	V _{13LR}	0.8	1.5	-	V
21	G Blank Gate Low Input Voltage	V _{13LG}	0.8	1.5	-	V
22	B Blank Gate Low Input Voltage	V _{13LB}	0.8	1.5	-	V
23	R Blank Gate High Input Voltage	V _{13HR}	-	1.5	2.0	V
24	G Blank Gate High Input Voltage	V _{13HG}	-	1.5	2.0	V
25	B Blank Gate High Input Voltage	V _{13HB}	-	1.5	2.0	V
26	Blank Gate Low Input Current	I _{13L}	-5.0	-2.0	-	μA
27	Blank Gate High Input Current	I _{13H}	-	0.01	1.0	μA

Table 3. DC Electrical Characteristics (Continued)

No	Parameter	Symbol	Value			Unit
			Min	Typ	Max	
28	R BRT LOW Output Voltage (POR)	VOporR	0.8	1.0	1.2	V
29	G BRT Low Output Voltage (POR)	VOporG	0.8	1.0	1.2	V
30	B BRT Low Output Voltage (POR)	VOporB	0.8	1.0	1.2	V
31	R-G Black Level Output Voltage	Δ R-GBL	-	0.0	Δ 0.2	V
32	G-B Black Level Output Voltage	Δ G-BBL	-	0.0	Δ 0.2	V
33	B-R Black Level Output Voltage	Δ B-RBL	-	0.0	Δ 0.2	V
34	R Output High Voltage	VOHR	6.2	7.5	9.0	V
35	G Output High Voltage	VOHG	6.2	7.5	9.0	V
36	B Output High Voltage	VOHB	6.2	7.5	9.0	V
37	R Blank Output Voltage	VOBR	-	0.1	0.2	V
38	G Blank Output Voltage	VOBG	-	0.1	0.2	V
39	B Blank Output Voltage	VOBB	-	0.1	0.2	V
40	SCL High Input Current	I10H	-	0.01	1.0	μ A
41	SDA High Input Current	I11H	-	0.01	1.0	μ A
42	SCL/SDA Low Level Input Voltage	VbusL	-	-	1.5	V
43	SCL/SDA High Level Input Voltage	VbusH	3	-	-	V
44	R Input Resistance	Rin	-	10	-	k Ω
45	G Input Resistance	Gin	-	10	-	k Ω
46	B Input Resistance	Bin	-	10	-	k Ω
47	R Spot Killer Voltage	VspotR	9.2	10.4	11.2	V
48	G Spot Killer Voltage	VspotG	9.2	10.4	11.2	V
49	B Spot Killer Voltage	VspotB	9.2	10.4	11.2	V
50	R POR Ext. Cut -Off Output Current	IctXpoR	300	350	400	μ A
51	G POR Ext. Cut -Off Output Current	IctxpoG	300	350	400	μ A
52	B POR Ext. Cut -Off Output Current	IctxpoB	300	350	400	μ A
53	R Cut -Off Output Current Range	Δ IctxR	440	540	640	μ A
54	G Cut -Off Output Current Range	Δ IctxG	440	540	640	μ A
55	B Cut -Off Output Current Range	Δ IctxB	440	540	640	μ A
56	R Cut -Off BRT Output Current Range	Δ IctbrtR	150	170	210	μ A
57	G Cut -Off BRT Output Current Range	Δ IctbrtG	150	170	210	μ A
58	B Cut-Off BRT Output Current Range	Δ IctbrtB	150	170	210	μ A
59	R Ext. Cut-Off Offset Output Current1	Ics1R	70	85	100	μ A

Table 3. DC Electrical Characteristics (Continued)

No	Parameter	Symbol	Value			Unit
			Min	Typ	Max	
60	G Ext. Cut-Off Offset Output Current1	Ics1G	70	85	100	μA
61	B Ext. Cut-Off Offset Output Current1	Ics1B	70	85	100	μA
62	R Ext. Cut-Off Offset Output Current2	Ics2R	140	160	180	μA
63	G Ext. Cut-Off Offset Output Current2	Ics2G	140	160	180	μA
64	B Ext. Cut-Off Offset Output Current2	Ics2B	140	160	180	μA
65	R Soft Blank Output Voltage	VOsoftR	-	0.1	0.2	V
66	G Soft Blank Output Voltage	VOsoftG	-	0.1	0.2	V
67	B Soft Blank Output Voltage	VOsoftB	-	0.1	0.2	V
68	R Brightness High Output Voltage	VOHR	2.5	3.0	3.5	V
69	G Brightness High Output Voltage	VOHG	2.5	3.0	3.5	V
70	B Brightness High Output Voltage	VOHB	2.5	3.0	3.5	V

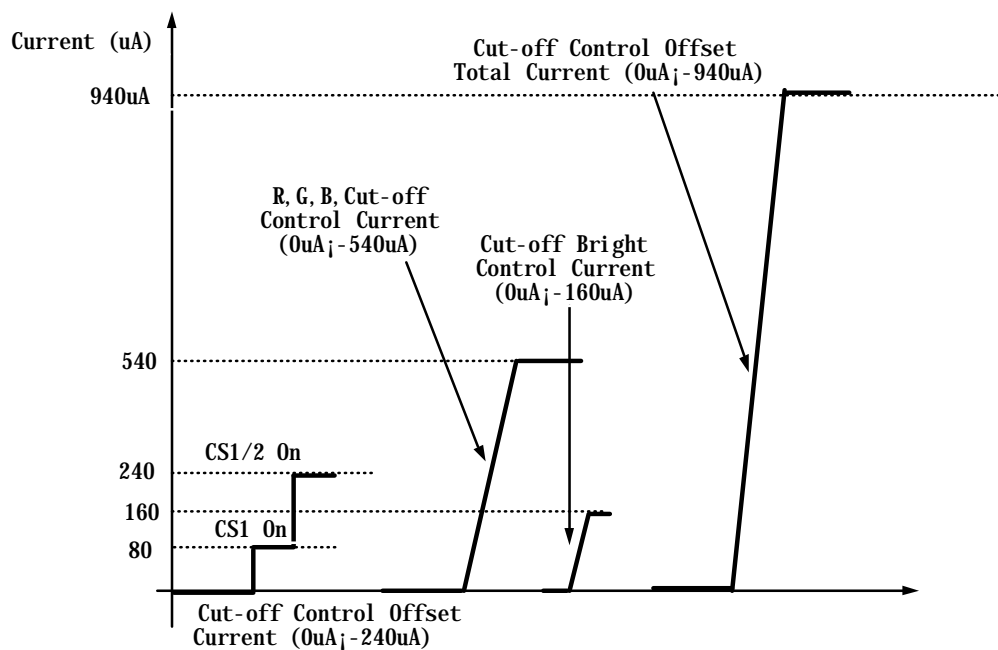

(Cut-off Control Offset Current & Sink Current Waveform)

AC Electrical Characteristics

(T_{amb} = 25°C, V_{CC} = 12 V, V_{DD} = 12 V)

Table 4. AC Electrical Characteristics

No	Parameter	Symbol	Value			Unit
			Min	Typ	Max	
71	R Video Bandwidth	f-3dBR	85	-	-	MHz
72	G Video Bandwidth	f-3dBG	85	-	-	MHz
73	B Video Bandwidth	f-3dBB	85	-	-	MHz
74	R Video Amp Gain	AvmaxR	15.5	17.5	19.5	dB
75	G Video Amp Gain	AvmaxG	15.5	17.5	19.5	dB
76	B Video Amp Gain	AvmaxB	15.5	17.5	19.5	dB
77	Max Gain Difference between R-G AMP	ΔAvmaxRG	-1.0	-	1.0	dB
78	Max Gain Difference between G-B AMP	ΔAvmaxGB	-1.0	-	1.0	dB
79	Max Gain Difference between B-R AMP	ΔAvmaxBR	-1.0	-	1.0	dB
80	Low Gain Difference between R-G AMP	ΔAvlowRG	-1.0	-	1.0	dB
81	Low Gain Difference between G-B AMP	ΔAvlowGB	-1.0	-	1.0	dB
82	Low Gain Difference between B-R AMP	ΔAvlowBR	-1.0	-	1.0	dB
83	R Sub Drive Ctrl Max. -Center	AvDRmax	-3	-4	-5	dB
84	G Sub Drive Ctrl Max. -Center	AvDGmax	-3	-4	-5	dB
85	B Sub Drive Ctrl Max. -Center	AvDBmax	-3	-4	-5	dB
86	R Sub Drive Ctrl Min. -Center	AvDRmin	-11	-8	-5	dB
87	G Sub Drive Ctrl Min. -Center	AvDGmin	-11	-8	-5	dB
88	B Sub Drive Ctrl Min. -Center	AvDBmin	-11	-8	-5	dB
89	R Contrast Ctrl Max. -Center	AvCRmax	-7	-6	-4	dB
90	G Contrast Ctrl Max. -Center	AvCGmax	-7	-6	-4	dB
91	B Contrast Ctrl Max. -Center	AvCBmax	-7	-6	-4	dB
92	R Contrast Ctrl Min. -Center	AvCRmin	-	-	-35	dB
93	G Contrast Ctrl Min. -Center	AvCGmin	-	-	-35	dB
94	B Contrast Ctrl Min. -Center	AvCBmin	-	-	-35	dB
95	R ABL Control Range	ΔABLR	-8.5	-11.5	-14.5	dB
96	G ABL Control Range	ΔABLG	-8.5	-11.5	-14.5	dB
97	B ABL Control Range	ΔABLB	-8.5	-11.5	-14.5	dB
98	R Video Amp THD	THDR	-	1.0	5.0	%
99	G Video Amp THD	THDG	-	1.0	5.0	%

Table 4. AC Electrical Characteristics (Continued)

No	Parameter	Symbol	Value			Unit
			Min	Typ	Max	
100	B Video Amp THD	THDB	-	1.0	5.0	%
101	R Video Rising Time	trR	-	4.0	5.0	nS
102	G Video Rising Time	trG	-	4.0	5.0	nS
103	B Video Rising Time	trB	-	4.0	5.0	nS
104	R Video Falling Time	tfR	-	4.0	5.0	nS
105	G Video Falling Time	tfG	-	4.0	5.0	nS
106	B Video Falling Time	tfB	-	4.0	5.0	nS
107	R Blank Output Rising Time	trBlankR	-	6.0	15.0	nS
108	G Blank Output Rising Time	trBlankG	-	6.0	15.0	nS
109	B Blank Output Rising Time	trBlankB	-	6.0	15.0	nS
110	R Blank Output Falling Time	tfBlankR	-	6.0	15.0	nS
111	G Blank Output Falling Time	tfBlankG	-	6.0	15.0	nS
112	B Blank Output Falling Time	tfBlankB	-	6.0	15.0	nS
113	R Blank Rising Prop. Delay	trBlankPrR	-	23	50	nS
114	G Blank Rising Prop. Delay	trBlankPrG	-	23	50	nS
115	B Blank Rising Prop. Delay	trBlankPrB	-	23	50	nS
116	R Blank Falling Prop. Delay	tfBlankPrR	-	20	45	nS
117	G Blank Falling Prop. Delay	tfBlankPrG	-	20	45	nS
118	B Blank Falling Prop. Delay	tfBlankPrB	-	20	45	nS
119	R Video Amp ISO1 10 kHz	ISO1_10KR	-	-65	-45	dB
120	R Video Amp ISO2 10 kHz	ISO2_10KG	-	-65	-45	dB
121	G Video Amp ISO1 10 kHz	ISO1_10KB	-	-65	-45	dB
122	G Video Amp ISO2 10 kHz	ISO2_10KR	-	-65	-45	dB
123	B Video Amp ISO1 10 kHz	ISO1_10KG	-	-65	-45	dB
124	B Video Amp ISO2 10 kHz	ISO2_10KB	-	-65	-45	dB
125	R Video Amp ISO1 10 MHz	ISO1_10MR	-	-50	-35	dB
126	R Video Amp ISO2 10 MHz	ISO2_10MR	-	-50	-35	dB
127	G Video Amp ISO1 10 MHz	ISO1_10MG	-	-50	-35	dB
128	G Video Amp ISO2 10 MHz	ISO2_10MG	-	-50	-35	dB
129	B Video Amp ISO1 10 MHz	ISO1_10MB	-	-50	-35	dB
130	B Video Amp ISO2 10 MHz	ISO2_10MB	-	-50	-35	dB

FUNCTIONAL DESCRIPTION

I²C BUS Recommended Operating Conditions

Table 5. I²C BUS Recommended Operating Conditions

Symbol	Description	Min	Typ	Max	Unit
V _{inH}	Input High Level Voltage	3.0	-	5.0	V
V _{inL}	Input Low Level Voltage	0	-	1.5	V
f _{SCL}	SCL Clock frequency	-	-	200	kHz
t _{BUF}	Hold time before a new transmission can start	1.3	-	-	uS
t _{HDS}	Hold time for Start conditions	0.6	-	-	uS
t _{SUP}	Set-Up time for Stop conditions	0.6	-	-	uS
t _{LOW}	The Low Period of SCL	1.3	-	-	uS
t _{HIGH}	The High Period of SCL	0.6	-	-	uS
t _{HDAT}	Hold time data	0.3	-	-	uS
t _{SUPDAT}	Set-Up time data	0.25	-	-	uS
t _R	Rise time of SCL	-	-	1.0	uS
t _F	Fall time of SCL	-	-	3.0	uS

I²C BUS Timing Requirement

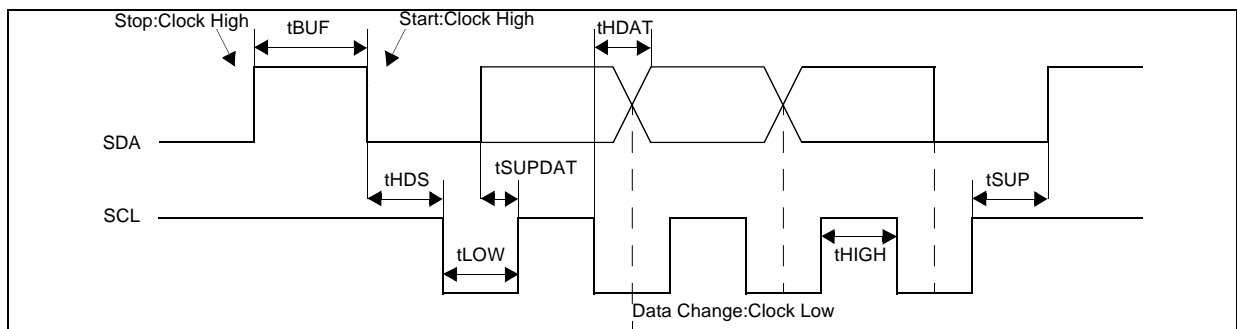

Figure 1. I²C BUS Timing Requirement

Register Description

1. Contrast Adjustment (8-Bits)

The Contrast adjustment is made by controlling simultaneously the gain of three internal variable gain amplifiers through the I²C bus interface.

The Contrast adjustment allows you to cover a typical range of 38 dB.

2. Sub Contrast Adjustments (8-Bits × 3)

These Adjustments are used to adjust the gain of each channel controlled by the I²C bus. The Sub Contrast adjustment allows you to cover a typical range of 12 dB.

3. Brightness Adjustment (5-Bits)

The Brightness adjustment controls to add the same black level (pedestal) to the 3-channel R/G/B signals by I²C bus.

4. Cut-Off Adjustments (8-Bits × 3)

These Adjustments are used to adjust the white balance of the each channel controlled by the I²C bus.

5. Cut-Off Brightness Adjustment (8-Bits)

The Cut-Off Brightness Adjustment controls the 3-channel Cut-Off by I²C bus.

6. Slave Address

The 2-wire serial interface is an I²C BUS interface.

The Slave address of the KA2504 is DCH (hexadecimal)

Bit 8	Bit 7	Bit 6	Bit 5	Bit 4	Bit 3	Bit 2	Bit 1
1	1	0	1	1	1	0	0 (W)

7. Data Transfer

All Bytes are sent MSB (Most Significant Bit) bit first and the write data transfer is closed by a STOP.

The MCU can write data into the KA2504 registers.

To write data into the KA2504, after a start, MCU must send :

- The I²C address slave byte with a low level for R/W bit (bit 1)
- The byte of the internal register address where the MCU wants to write data. (SUB Address)
- The Data sent to slave
- Stop

- 1-Byte Data Transfer

STA	Slave ADRS	W	A	SUB ADRS	A	DATA	A	STO
-----	------------	---	---	----------	---	------	---	-----

- Multi-Data Transfer

STA	Slave ADRS	W	A	Sub ADRS	A	DATA	A	Sub ADRS	A	DATA	A	- - -
-----	------------	---	---	----------	---	------	---	----------	---	------	---	-------

- - -	Sub ADRS	A	DATA	A	STO
-------	----------	---	------	---	-----

- Automatic increment

The automatic increment feature of the slave address enables a quick slave receiver initialization within one transmission by the I²C BUS controller.

STA	Slave ADRS	W	A	Auto ADRS	A	DATA (00H)	A	DATA (01H)	A	DATA (02H)	A	- - -
-----	------------	---	---	-----------	---	------------	---	------------	---	------------	---	-------

- - -	DATA (07H)	A	DATA (08H)	A	STO
-------	------------	---	------------	---	-----

8. I²C Write Operation: A complete data transfer

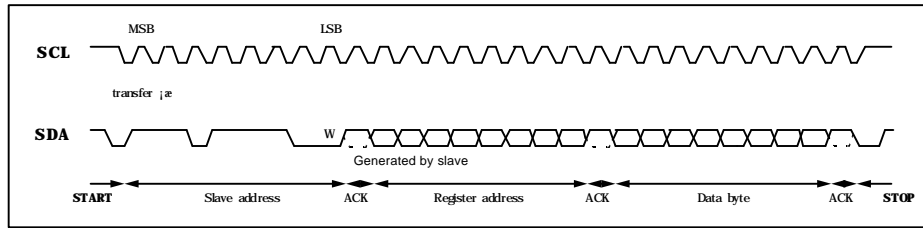

The automatic increment feature of the sub address enables a quick slave receiver initialization within one transmission, by the I²C Bus controller.

9. Sub Address Allocation Map (Slave address: DCH)

SUB Address [Hex]	Function								Initial Value [Hex]
	D7	D6	D5	D4	D3	D2	D1	D0	
00H	Contrast Control								80H
01H	SBLK	CS1	CS2	Brightness Control					00H
02H	R Sub Contrast Control								80H
03H	G Sub Contrast Control								80H
04H	B Sub Contrast Control								80H
05H	Cut-Off Brightness Control								80H
06H	R Cut-Off Control								80H
07H	G Cut-Off Control								80H
08H	B Cut-Off Control								80H

Note: SBLK: Soft Blanking Switch (1: ON, 0: OFF)
 CS1/2: Cut-off Control Offset Current Switch (CS1: 80µA, CS2: 160µA)

- Contrast Register (SUB ADRS: 00H) (Vin = 0.56 Vpp, bright: 00H, sub: FFH)

Hex	D7	D6	D5	D4	D3	D2	D1	D0	Contrast (Vpp)	Gain (dB)	Int value (Hex)
00	0	0	0	0	0	0	0	0	0	-30.0	
80	1	0	0	0	0	0	0	0	1.12	11.5	0
FF	1	1	1	1	1	1	1	1	4.2	17.5	
increment/bit									0.0164	-	

- Brightness Register (3-ch)(SUB ADRS: 01H) (cont: 80H, sub: FFH)

Hex	D4	D3	D2	D1	D0	Brightness (V)	Int. value (Hex)
00	0	0	0	0	0	1	0
10	1	0	0	0	0	2	
1f	1	1	1	1	1	3	
increment/bit						0.0625	

- SUB Contrast Register (R/G/B-ch)(SUB ADRS: 02/03/04H) (Vin = 0.56 Vpp, bright: 00H, cont: FFH)

Hex	D7	D6	D5	D4	D3	D2	D1	D0	Sub Contrast (Vpp)	Gain (dB)	Int. value (Hex)
00	0	0	0	0	0	0	0	0	1.33	7.5	
80	1	0	0	0	0	0	0	0	2.65	13.5	0
FF	1	1	1	1	1	1	1	1	4.2	17.5	
increment/bit									0.0123		

- Cut-Off Brightness Register (3-ch) (SUB ADRS: 05H)

Hex	D7	D6	D5	D4	D3	D2	D1	D0	Cut-Off brightness (μA)	Int. value (Hex)
00	0	0	0	0	0	0	0	0	0	
80	1	0	0	0	0	0	0	0	90	0
FF	1	1	1	1	1	1	1	1	180	
increment/bit									0.703	

- Cut-Off Register (R/G/B-ch) (SUB ADRS: 06/07/08H) (cont: 80H, sub: FFH)

Hex	D7	D6	D5	D4	D3	D2	D1	D0	Cut-Off (μA)	Int. value (Hex)
00	0	0	0	0	0	0	0	0	0	
80	1	0	0	0	0	0	0	0	270	0
FF	1	1	1	1	1	1	1	1	540	
increment/bit									2.11	

APPLICATION BOARD CIRCUIT

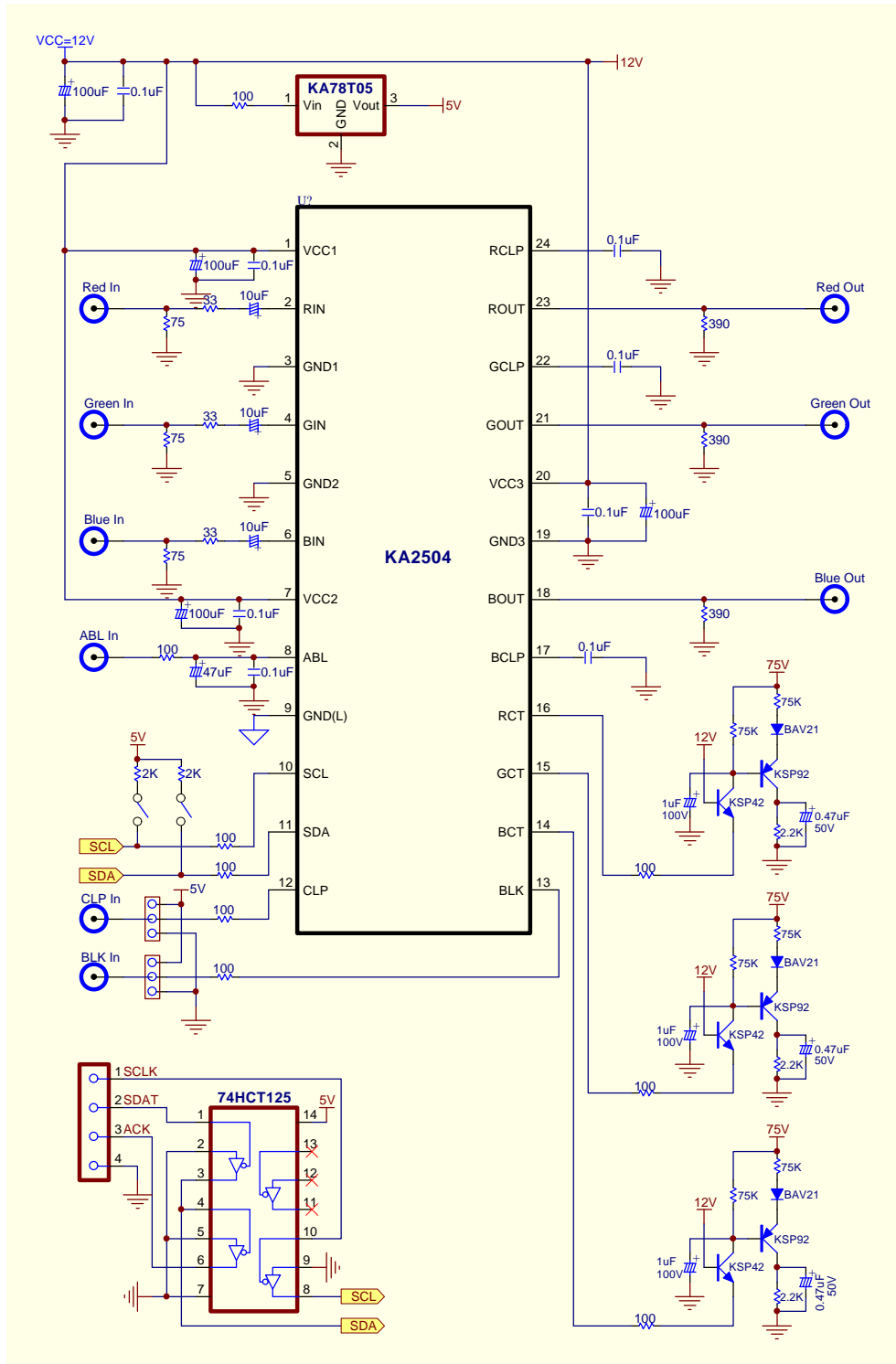

CHARACTERISTICS CURVE

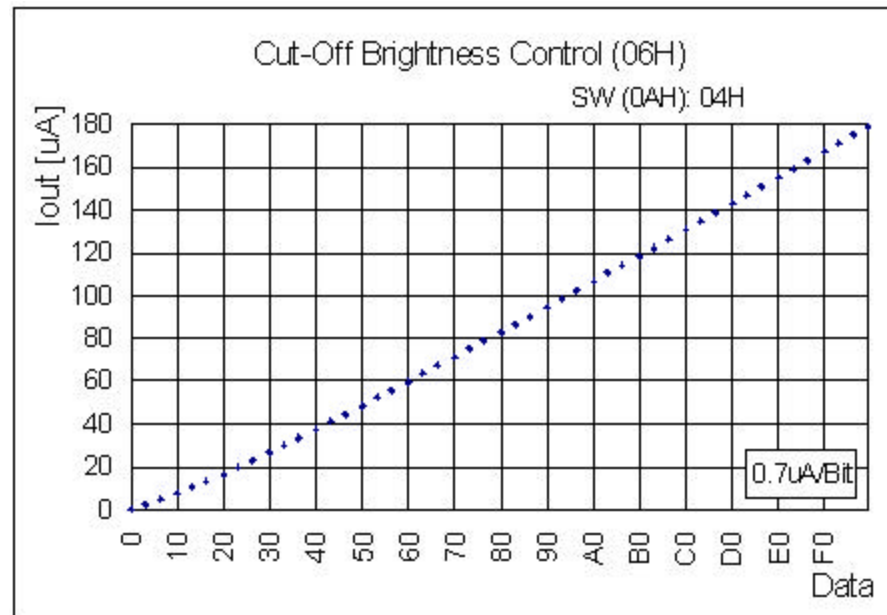
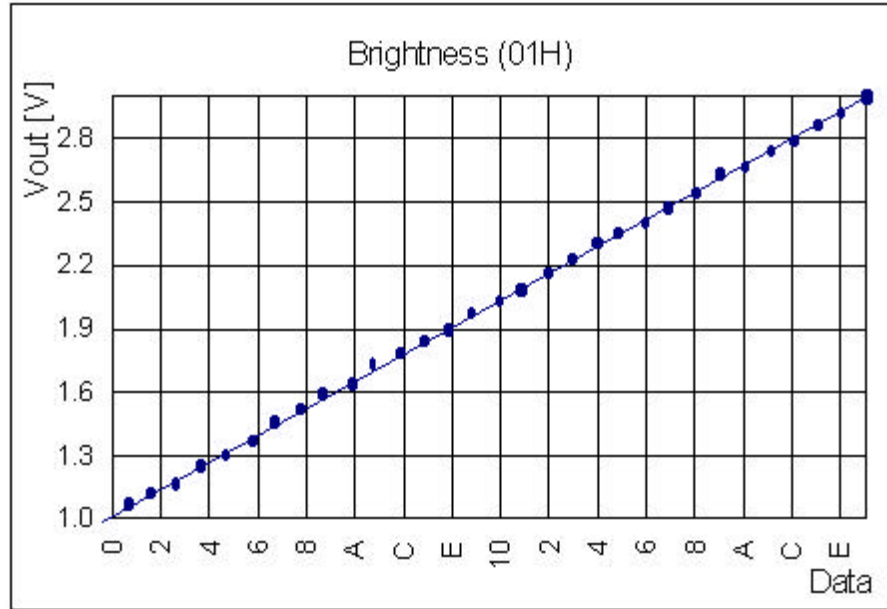

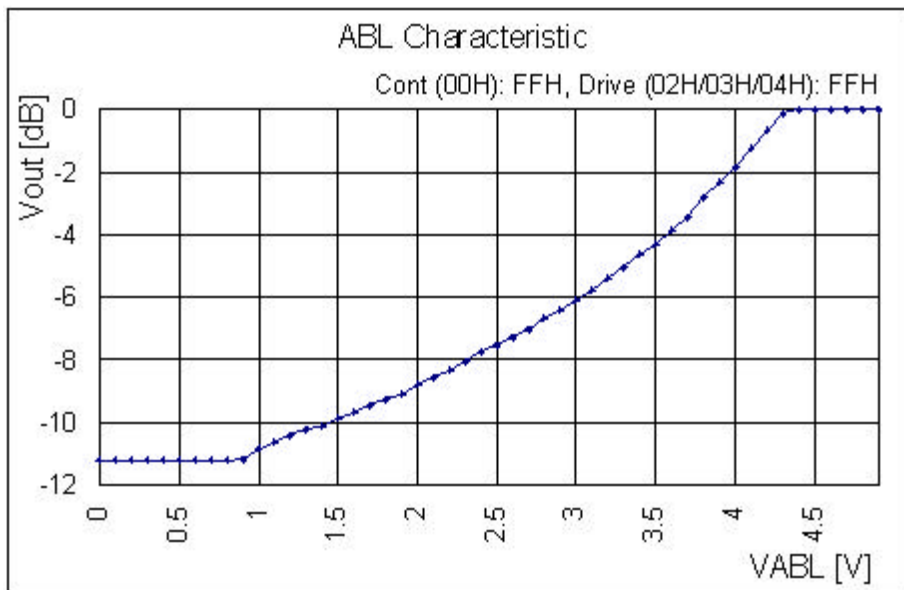
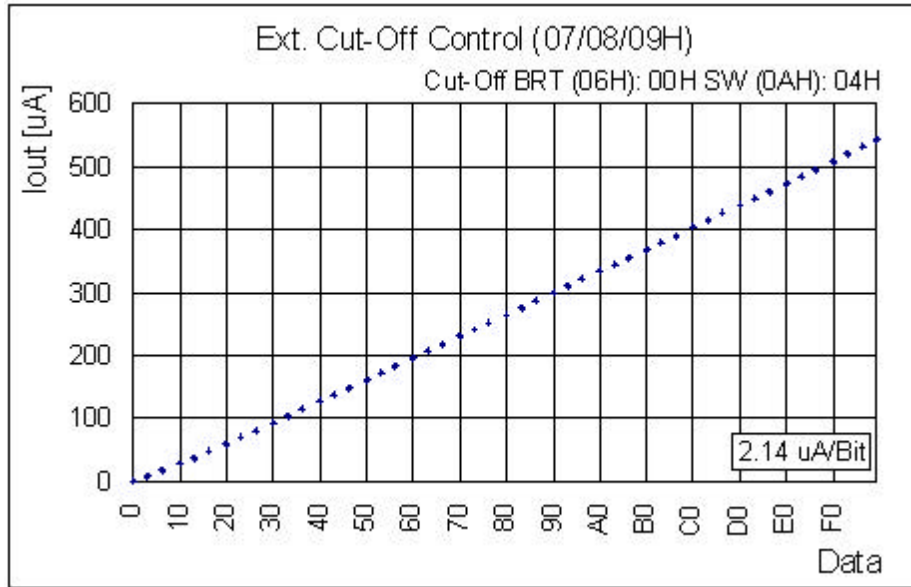

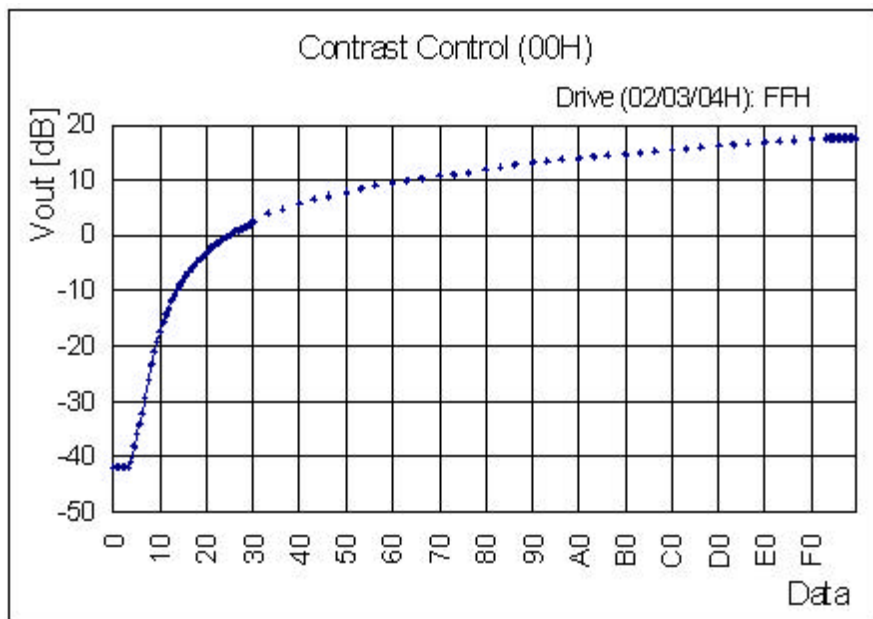
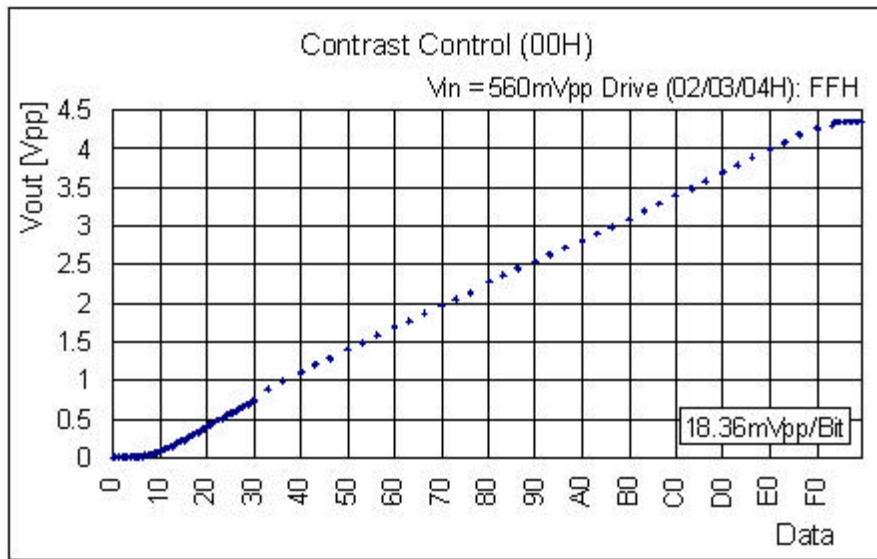

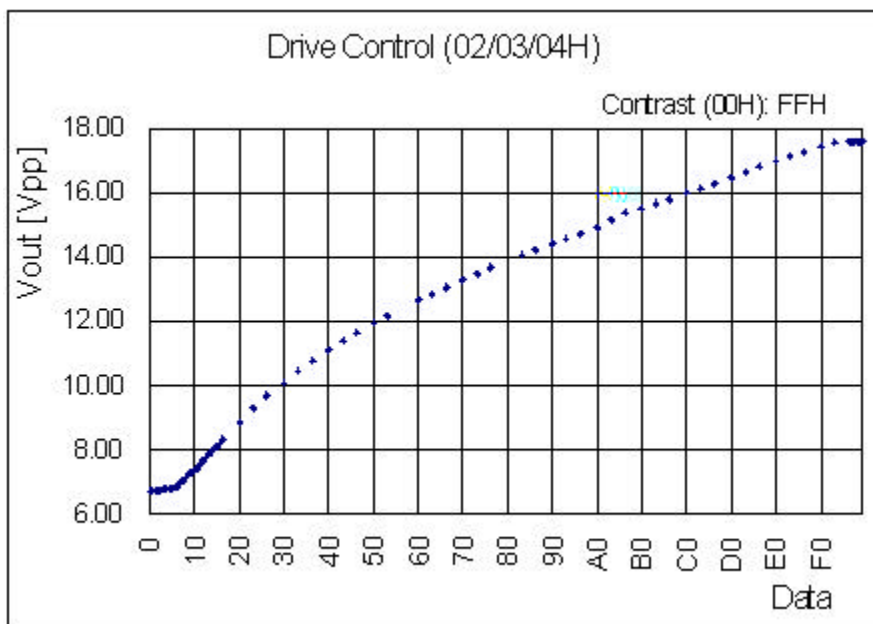
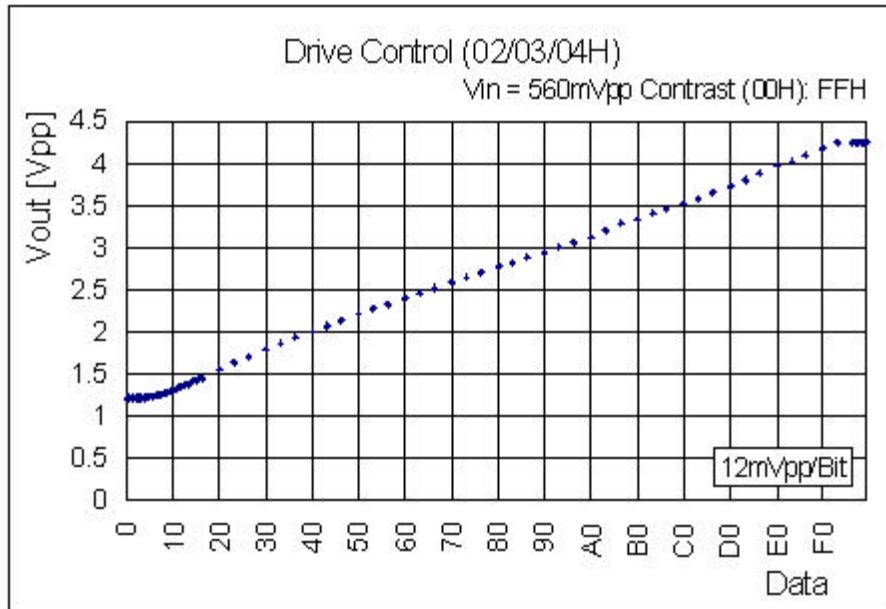



LittleDiode supplies new, hard to find or obsolete electronic components and semiconductors all over the world.

With over two million different components listed you are sure to find the part you need.

Feel free to visit us today at our online store:

LittleDiode.com

Looking forward to providing you with the best possible service.