

# KA2822D/KA2822BD

## 3-Phase BLDC Motor Driver

### Features

- 3-phase, full-wave, linear BLDC motor driver with 2 hall sensors
- Built-in soft switching drive circuit
- 300 or 360 RPM speed control
- Snubberless
- Built-in chip enable function
- Built-in digital speed control circuit
- Built-in current limit circuit
- Index sensorless
- Built-in TSD (Thermal shutdown)
- Low saturation voltage
- Digital input: TTL, 5V CMOS compatible
- Built-in current-mode control circuit (IPEAK: 1A)

### Description

The KA2822D/KA2822BD is a monolithic integrated circuit, and suitable for the three-phase spindle motor driver of FDD system.

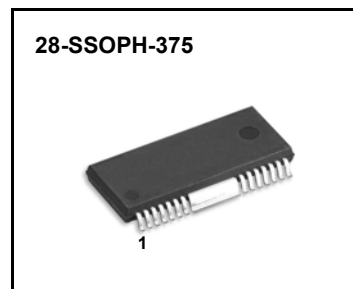

### Typical Application

- 3.5-Inch floppy disk drive (FDD) spindle motor
- Other 3-phase BLDC motor

### Ordering Information

Device	Package	Operating Temp.
KA2822D	28-SSOPH-375	0 ~ 75°C
KA2822DTF	28-SSOPH-375	0 ~ 75°C
KA2822BD	28-SSOPH-375	0 ~ 75°C
KA2822BDTF	28-SSOPH-375	0 ~ 75°C

## Pin Assignments

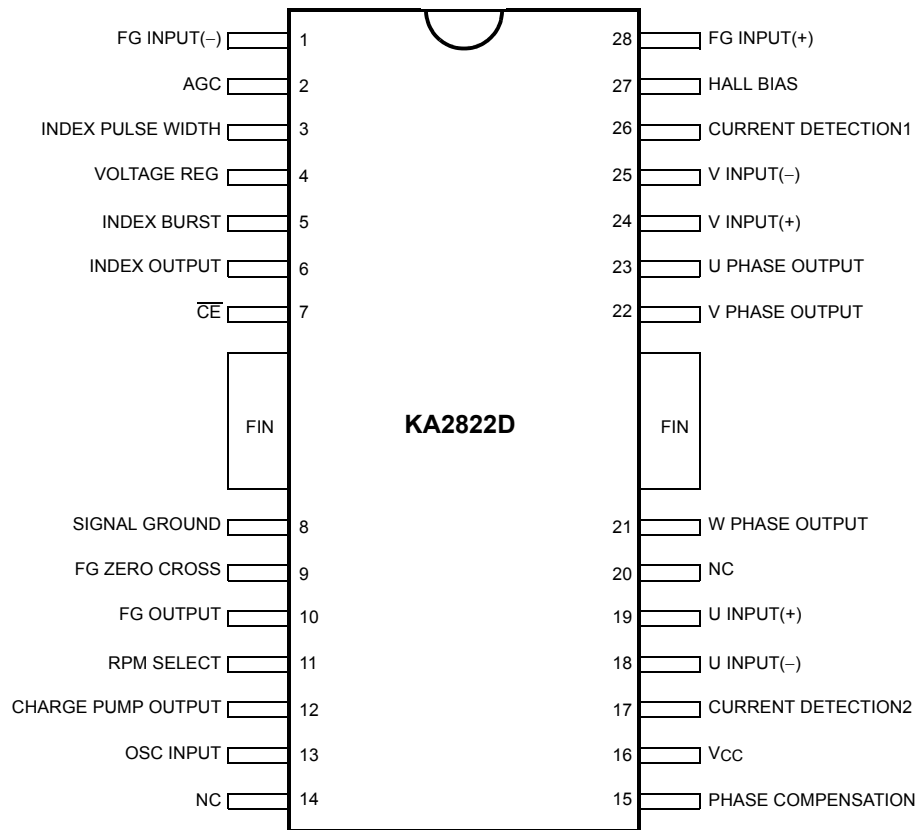

## Pin Definitions

Pin Number	Pin Name	I/O	Pin Function Description
1	FG_INPUT	I	Negative input pin FG signal amp.
2	AGC	I	Automatic gain control input pin
3	INDEX PULSE WIDTH	O	Index pulse width detection (1.1V) pin
4	VOLTAGE REGULATOR	O	Voltage (2.2V) generator output pin
5	INDEX BURST	O	Index pulse width detection (1.4V) pin
6	INDEX OUTPUT	O	Index pulse output pin
7	CE	I	Chip enable (Active low)
8	SIGNAL GROUND	-	Signal ground
9	FG ZERO CROSS	O	FG signal zero cross detection pin
10	FG OUTPUT	O	FG signal output pin
11	RPM SELECT	I	RPM selection pin (L: 300, H: 360rpm)
12	CHARGE PUMP OUTPUT	O	Charge pump output pin
13	OSC INPUT	I	1MHz oscillation input pin
14	NC	-	No connection
15	PHASE COMPENSATION	I	Phase compensation cap. connection pin
16	VCC	-	5V power supply pin
17	CURRENT DETECTION2	I	Over current detection pin
18	U INPUT (-)	I	Negative input pin of U phase amp
19	U INPUT (+)	I	Positive input pin of U phase amp
20	NC	-	No connection
21	W PHASE OUTPUT	O	W phase output pin
22	V PHASE OUTPUT	O	V phase output pin
23	U PHASE OUTPUT	O	U phase output pin
24	U INPUT (+)	I	Positive input pin of V phase amp
25	V INPUT (-)	I	Negative input pin of V phase amp
26	CURRENT DETECTION1	I	Over current detection pin
27	HALL BIAS	I	Hall sensor bias input pin
28	FG INPUT (+)	I	Positive input pin of FG signal amp
FIN	POWER GROUND	-	Power ground

# Internal Block Diagram

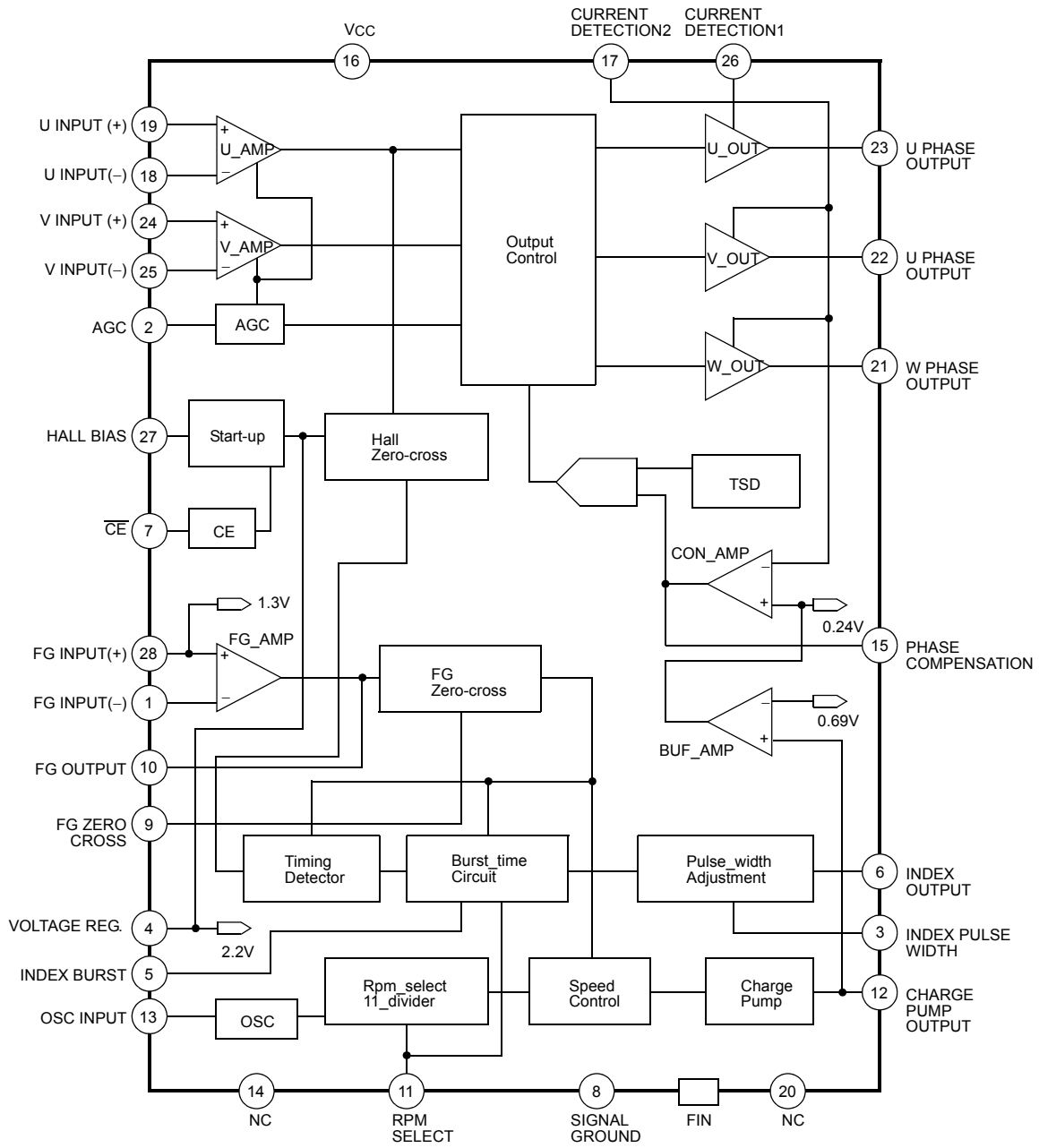

## Equivalent Circuits

<p style="text-align: center;"><b>U_amp, V_amp input</b></p>	<p style="text-align: center;"><b>U, V, W drive output and current detection 1, 2</b></p>
<p style="text-align: center;"><b>FG input and FG output</b></p>	<p style="text-align: center;"><b>OSC input</b></p>
<p style="text-align: center;"><b>CE input</b></p>	<p style="text-align: center;"><b>Hall bias input and voltage regulator output</b></p>

## Equivalent Circuits

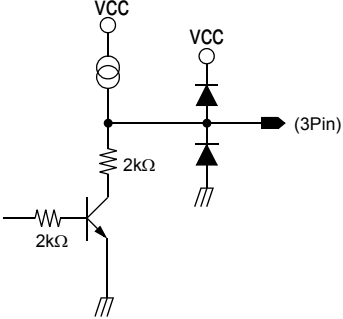
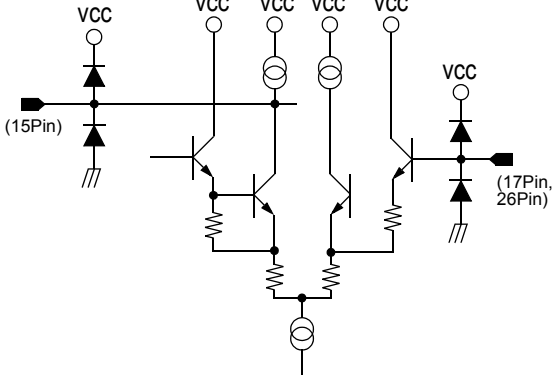
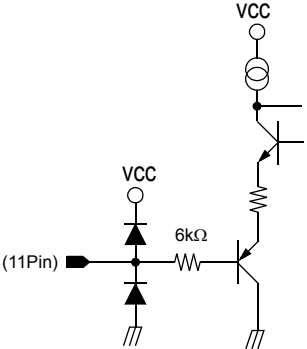
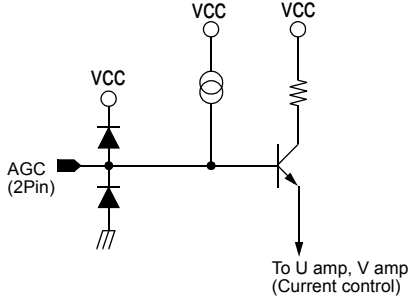
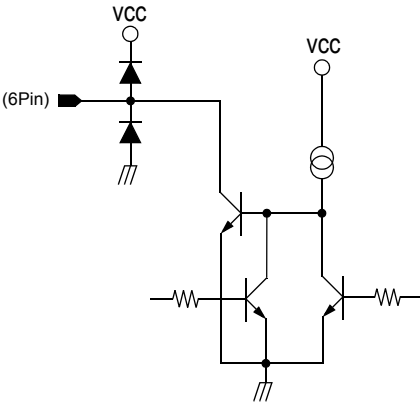
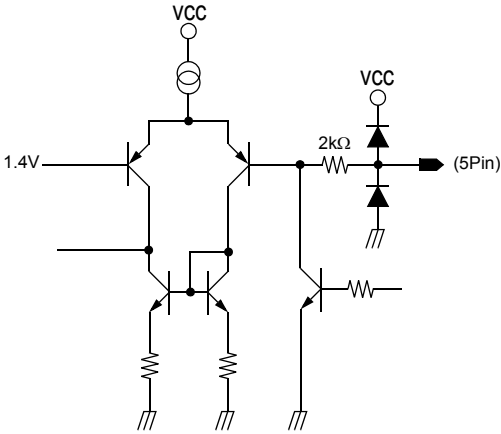
Index pulse width detection output	Phase compensation and current detection 1, 2
	
RPM select input	AGC input
	
Index output	Index burst output
	

## Equivalent Circuits

**FG zero cross output**

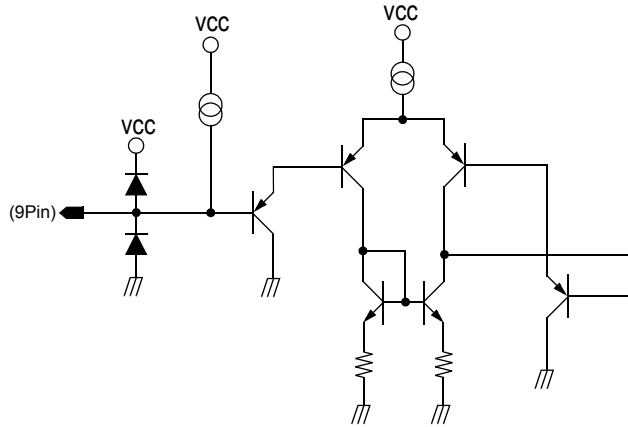

**Charge pump output**

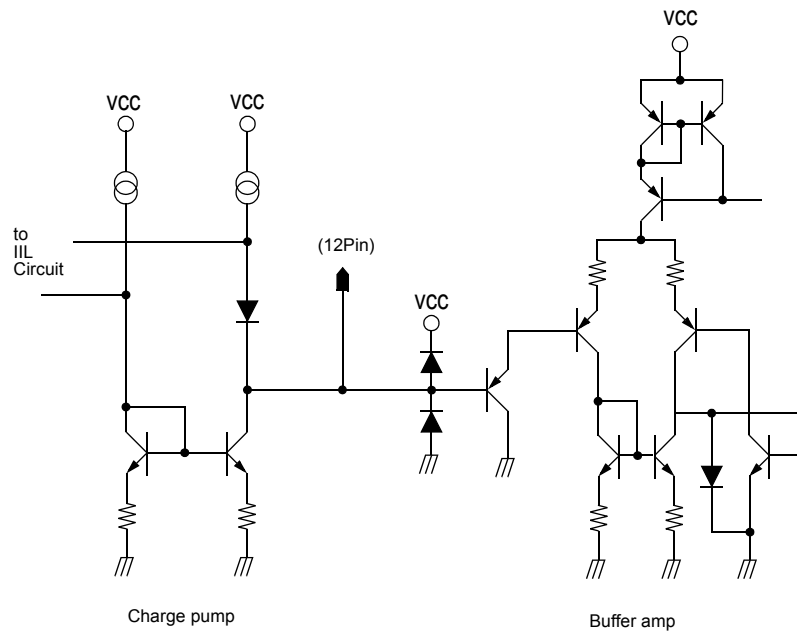

## Absolute Maximum Rating (Ta=25°C)

Parameter	Symbol	Value	Unit
Maximum power supply voltage	VCCMAX	7.0	V
Maximum input voltage	VINMAX	0 ~ VCC	V
Maximum output current	IOMAX	1	A
Normal output current	IO	0.7	A
Power dissipation	PD	1.5	W
Operating temperature	TA	0 ~ 75	°C
Junction temperature	TJ	150	°C
Storage temperature	TSTG	-55 ~ +125	°C

## Power Dissipation Curve

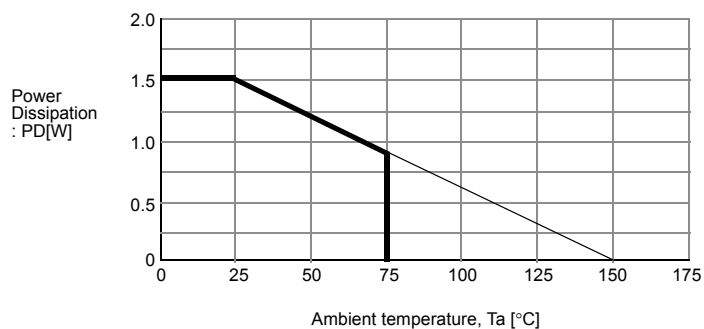

Power dissipation decreases in the rate of 13.5mW / °C when mounted on 50mm × 50mm × 1mm PCB (Phenolic resin material) and used above Ta=25°C.

## Recommended Operating Conditions (Ta=25°C)

Parameter	Symbol	Min.	Typ.	Max	Unit
Supply voltage	VCC	4.5	5.0	5.5	V
Ambient operating temperature range	Ta	0	-	+70	°C

## Temperature Characteristic

Parameter	Symbol	Min.	Typ.	Max	Unit
Thermal shutdown temperature <sup>note</sup>	TSD	125	150	-	°C

### NOTE:

Reference value

## Electrical Characteristics

(Ta=25°C, VCC=5V)

Parameter	Symbol	Conditions	Min.	Typ.	Max.	Unit
<b>SUPPLY CURRENT</b>						
Supply current 1	ICCO	$\overline{VCC}=5.5V$ $\overline{CE}=H, RPM=L$	-	1.0	2.0	mA
Supply current 2	ICC	$VCC=5.5V, \overline{CE}=L$	-	15	23	mA
<b>CHIP ENABLE</b>						
Input current	ICE	$\overline{CE}=0\sim 5V$	-	5	10	$\mu A$
Input low voltage	VCEL	-	-	-	1.0	V
Input high voltage	VCEH	-	3.5	-	-	V
<b>RPM SELECT</b>						
Input current	IRPM	$\overline{CE}=0\sim 5V$	-	5	10	$\mu A$
Input low voltage	VRPML	-	-	-	1.0	V
Input high voltage	VRPMH	-	3.5	-	-	V
<b>HALL AMP</b>						
Input resistance <sup>note</sup>	RIN	-	1	10	-	k $\Omega$
Common mode input voltage range <sup>note</sup>	VCOM	-	2.0	-	VCC	V
Differential input voltage range <sup>note</sup>	VDIF	-	140	-	420	mVPP
<b>START-UP</b>						
Hall bias voltage 1	VHB1	$I_H=4mA, \overline{CE}=L$	2.3	2.5	2.7	V
Hall bias voltage 2	VHB2	$I_H=10mA, \overline{CE}=L$	2.7	2.9	3.1	V
Reference voltage	Vref	$I_O=1mA, \overline{CE}=L$	1.7	2.2	2.7	V
Bias off current	IHOFF	$V_H=5.5V, \overline{CE}=H$	-	5	10	$\mu A$
<b>OUTPUT AMP</b>						
Leakage current	ICER	-	-	0.5	1	mA
Saturation voltage 1	Vsat1	$I_O=0.35A$	-	1.0	1.2	V
Saturation voltage 2	Vsat2	$I_O=0.7A$	-	1.3	1.8	V
<b>BUFFER &amp; CONTROL AMP</b>						
Voltage gain 1 <sup>note</sup>	GCT1	-	-	-11	-	dB
Reference voltage 1 <sup>note</sup>	Vref1	Current limiter voltage	0.205	0.208	0.210	V
Reference voltage 2 <sup>note</sup>	Vref2	Control begin voltage	-	0.69	-	V

### Notes:

Reference value

**Electrical Characteristics** (Continued)

(Ta=25°C, VCC=5V)

Parameter	Symbol	Conditions	Min.	Typ.	Max.	Unit
<b>CHARGE PUMP</b>						
Charge current	ICP-	RPM=L	-15	-20	-25	μA
Discharge current	ICP+	RPM=L	15	20	25	μA
Current ratio <sup>note</sup>	IR	ICP+ / ICP-	0.9	1.0	1.1	-
Off current	I <sub>OFF</sub>	V <sub>CP</sub> =0.63V	-	-	50	nA
Clamp voltage <sup>note</sup>	V <sub>C<sub>LP</sub></sub>	-	-	1.3	1.5	V
<b>FG AMP</b>						
Output DC voltage <sup>note</sup>	V <sub>FG</sub>	-	1.0	1.3	1.6	V
Voltage gain 2	G <sub>FG</sub>	-	24	34	44	dB
Input voltage range <sup>note</sup>	V <sub>IN</sub>	-	2.0	-	20	mV <sub>P-P</sub>
Noise margin 1 <sup>note</sup>	N <sub>D</sub>	Differential noise	-	-	0.5	mV <sub>P-P</sub>
Noise margin 2 <sup>note</sup>	N <sub>C</sub>	Common mode noise	-	-	0.5	V <sub>P-P</sub>
<b>SPEED CONTROL</b>						
Count range 1 <sup>note</sup>	N1	RPM=L	-	1666.5	-	-
Count range 2 <sup>note</sup>	N2	RPM=H	-	1388.5	-	-
Operating freq.	F <sub>D</sub>	-	-	1.0	1.1	MHz
<b>BURST ADJUSTMENT</b>						
Input current	I <sub>BI</sub>	-	-	1	2	μA
Threshold voltage 1	V <sub>TH1</sub>	RPM=L	1.2	1.45	1.7	V
Threshold voltage 2	V <sub>TH2</sub>	RPM=H	1.05	1.3	1.55	V
<b>PULSE WIDTH ADJUSTMENT</b>						
Ct2 charge current	I <sub>CT2</sub>	-	-19	-25	-36	μA
Threshold voltage 3	V <sub>TH3</sub>	-	0.9	1.1	1.3	V
<b>INDEX OUTPUT</b>						
Output leakage current <sup>note</sup>	I <sub>OH</sub>	-	-	1	2	μA
Output low voltage	V <sub>O1</sub>	I <sub>O</sub> =1mA	-	0.2	0.4	V

**Notes:**

Reference value

## Application Information

### 1. Chip Enable

This function turns on or off all blocks by low or high signal.

### 2. U, V And W Phase Output Amp

These amplifiers drives three output phases - U, V, and W which have 120(degree) phase differences with each other. The three phase waveforms are made with the two hall sensor signals by synthesizing the third phase signal.

### 3. Speed Control Part

This function compares the real motor rotation frequency with the 300 or 360Hz pulse divided from 1MHz clock pulse for removing speed error when motor is on and speed error is detected by PLL.

The speed error sent to charge pump part which repeats charge and discharge controls the output current of the output amp to keep a stable rotation.

## Typical Performance Characteristics

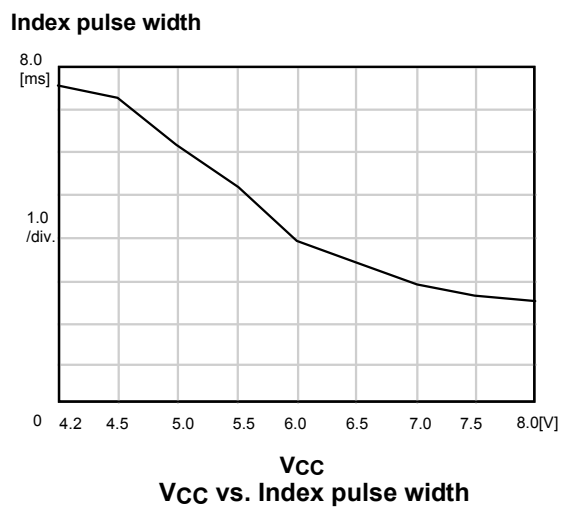
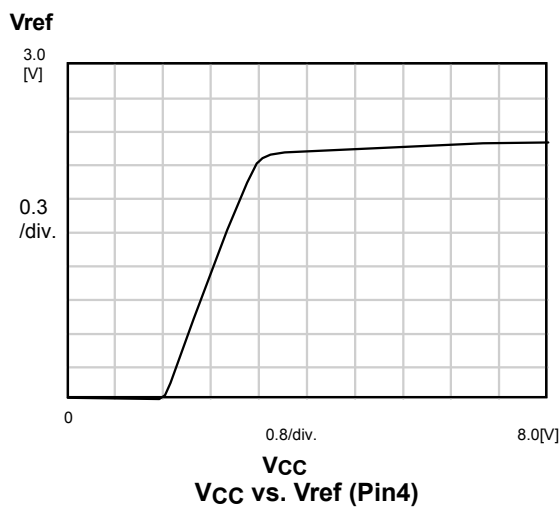
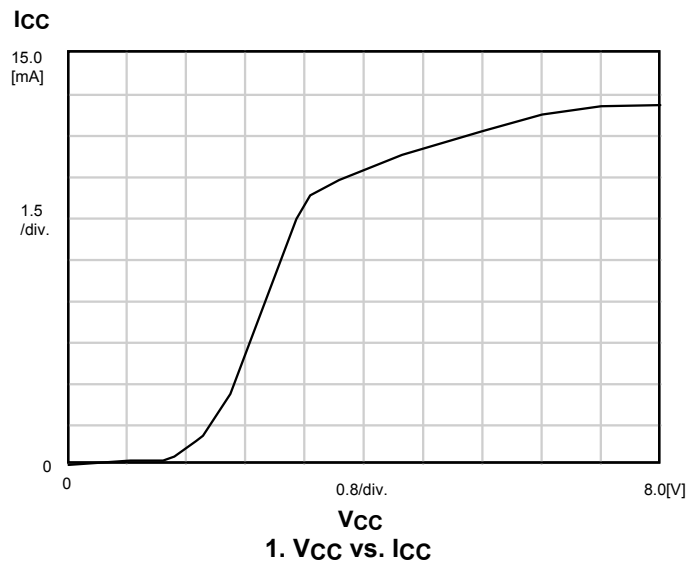

# Typical Application Circuits

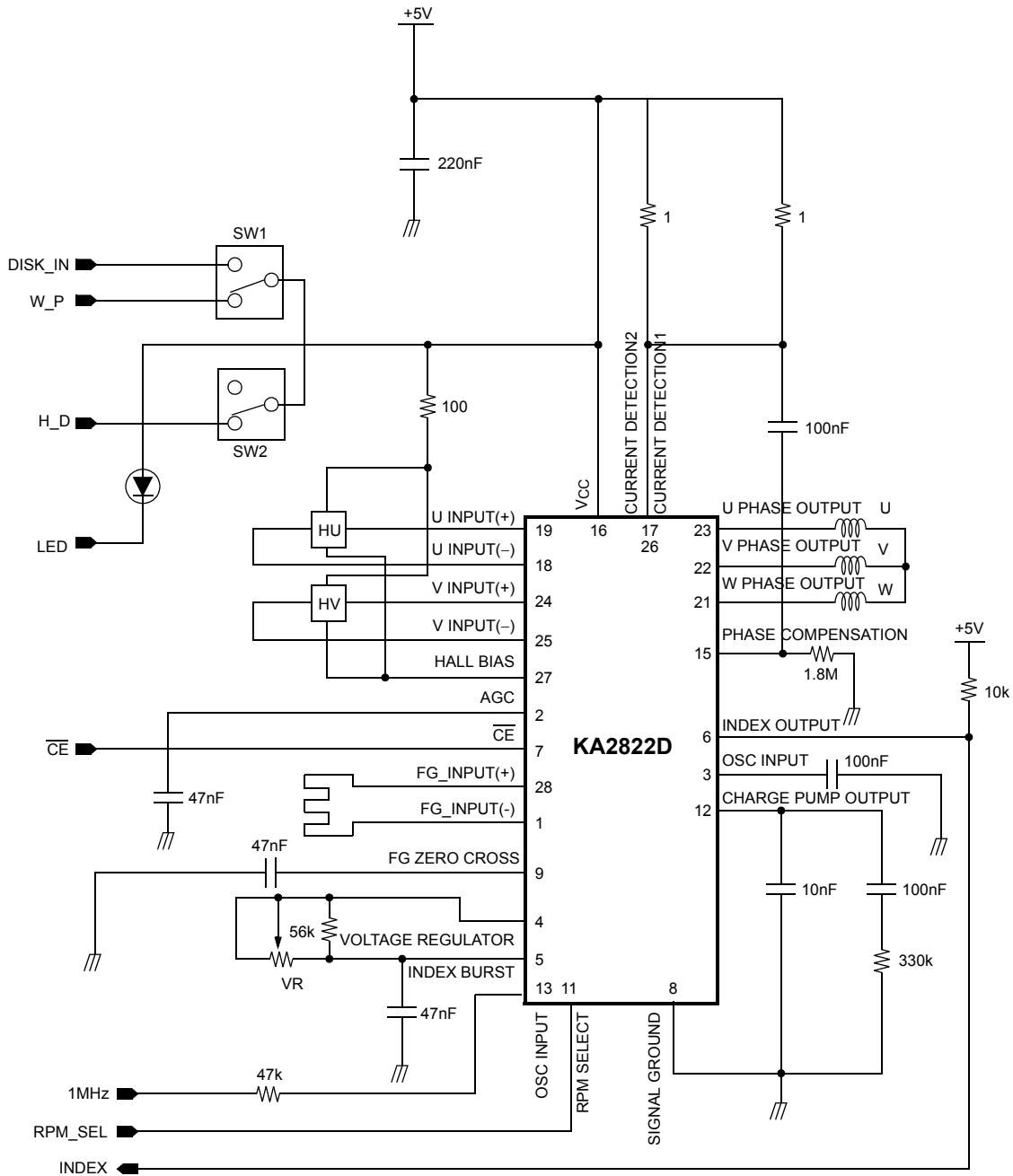



**DISCLAIMER**

FAIRCHILD SEMICONDUCTOR RESERVES THE RIGHT TO MAKE CHANGES WITHOUT FURTHER NOTICE TO ANY PRODUCTS HEREIN TO IMPROVE RELIABILITY, FUNCTION OR DESIGN. FAIRCHILD DOES NOT ASSUME ANY LIABILITY ARISING OUT OF THE APPLICATION OR USE OF ANY PRODUCT OR CIRCUIT DESCRIBED HEREIN; NEITHER DOES IT CONVEY ANY LICENSE UNDER ITS PATENT RIGHTS, NOR THE RIGHTS OF OTHERS.

**LIFE SUPPORT POLICY**

FAIRCHILD'S PRODUCTS ARE NOT AUTHORIZED FOR USE AS CRITICAL COMPONENTS IN LIFE SUPPORT DEVICES OR SYSTEMS WITHOUT THE EXPRESS WRITTEN APPROVAL OF THE PRESIDENT OF FAIRCHILD SEMICONDUCTOR CORPORATION. As used herein:

1. Life support devices or systems are devices or systems which, (a) are intended for surgical implant into the body, or (b) support or sustain life, and (c) whose failure to perform when properly used in accordance with instructions for use provided in the labeling, can be reasonably expected to result in a significant injury of the user.
2. A critical component in any component of a life support device or system whose failure to perform can be reasonably expected to cause the failure of the life support device or system, or to affect its safety or effectiveness.



LittleDiode supplies new, hard to find or obsolete electronic components and semiconductors all over the world.

With over two million different components listed you are sure to find the part you need.

Feel free to visit us today at our online store:

[LittleDiode.com](http://LittleDiode.com)

Looking forward to providing you with the best possible service.