

KA3011BD

3-Phase BLDC Motor Driver

Features

- 3-phase, full-wave, linear BLDC motor driver
- Power save at stop mode
- Built-in current limiter
- Built-in TSD (Thermal shutdown) circuit
- Built-in 3X or 1X hall FG output
- Built-in hall bias circuit
- Built-in rotational direction detector
- Built-in reverse rotation preventer
- Built-in short braker
- Corresponds to 3.3V or 5V DSP

Description

The KA3011BD is a monolithic IC, suitable for a 3-phase spindle motor driver of a CD-media system.



Typical Applications

- Compact disk ROM (CD-ROM) spindle motor
- Compact disk RW (CD-RW) spindle motor
- Digital video disk ROM (DVD-ROM) spindle motor
- Digital video disk RAM (DVD-RAM) spindle motor
- Digital video disk Player (DVDP) spindle motor
- Other compact disk media spindle motor
- Other 3-phase BLDC motor

Ordering Information

Device	Package	Operating Temp.
KA3011BD	28-SSOPH-375	-25°C ~ +75°C
KA3011BDTF	28-SSOPH-375	-25°C ~ +75°C

Pin Assignments

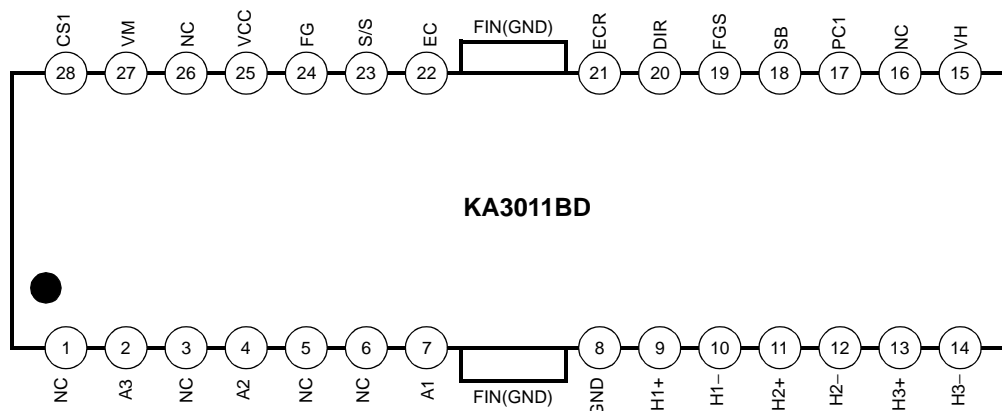

Pin Definitions

Pine Number	Pin Name	I/O	Pin Function Description
1	NC	-	No connection
2	A3	O	Output (A3)
3	NC	-	No connection
4	A2	O	Output (A2)
5	NC	-	No connection
6	NC	-	No connection
7	A1	O	Output (A1)
8	GND	-	Ground
9	H1+	I	Hall signal (H1+)
10	H1-	I	Hall signal (H1-)
11	H2+	I	Hall signal (H2+)
12	H2-	I	Hall signal (H2-)
13	H3+	I	Hall signal (H3+)
14	H3-	I	Hall signal (H3-)
15	VH	I	Hall bias
16	NC	-	No connection
17	PC1	-	Phase compensation capacitor
18	SB	I	Short brake
19	FGS	I	Frequency generation selection
20	DIR	O	Rotational direction output
21	ECR	I	Output current control reference
22	EC	I	Output current control voltage
23	S/S	I	Power save (Start/Stop switch)
24	FG	O	Frequency generation waveform (3X or 1X hall frequency)
25	VCC	-	Supply voltage (Signal)
26	NC	-	No connection
27	VM	-	Supply voltage (Motor)
28	CS1	-	Output current detection

Internal Block Diagram

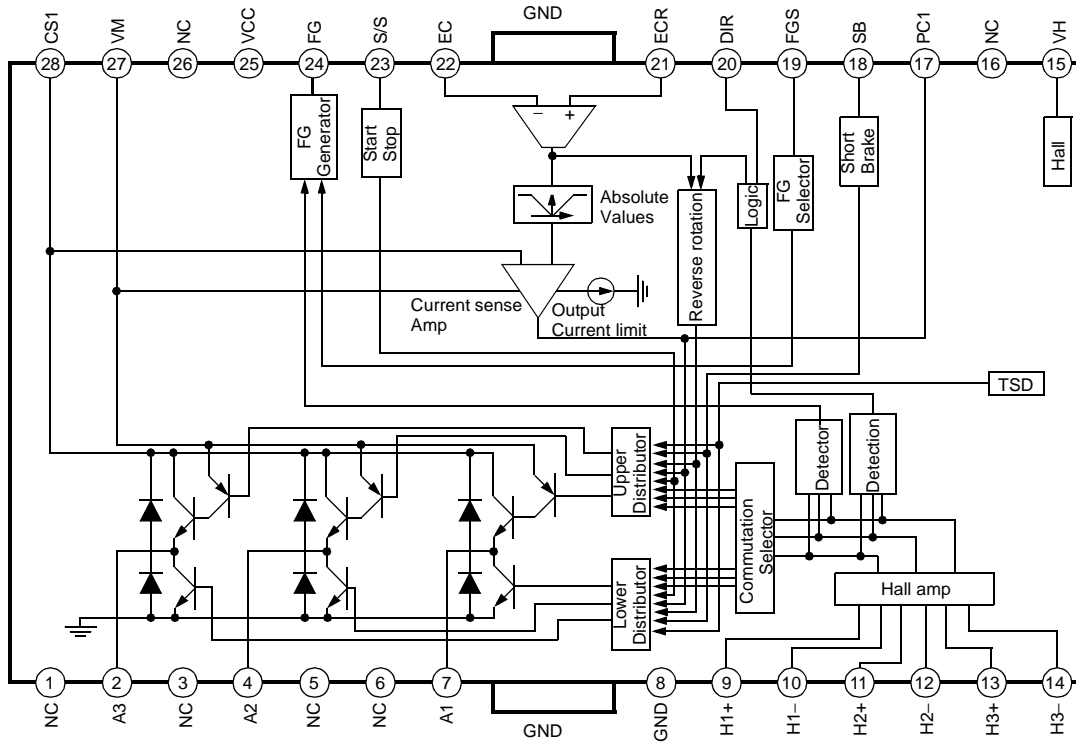

Equivalent Circuits

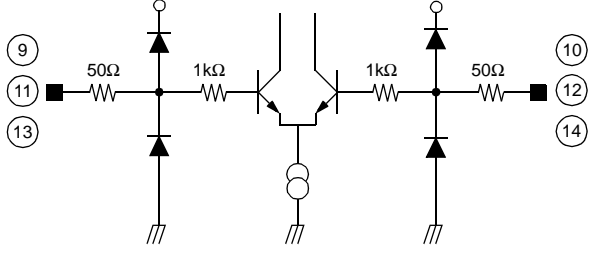
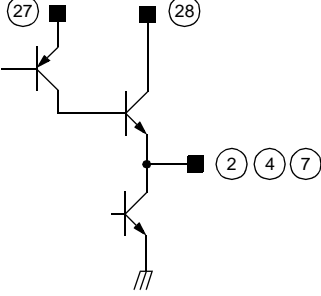
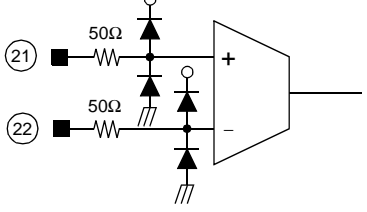
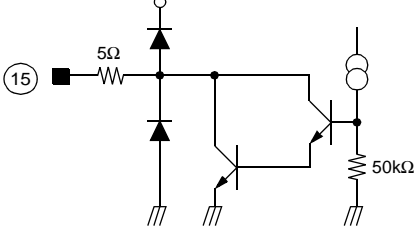
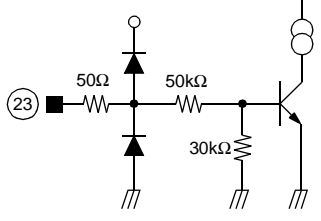
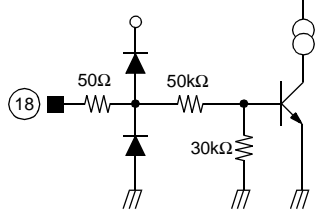
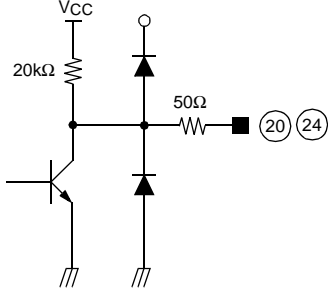
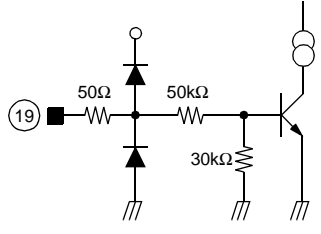
Hall input	Driver output
 <p>Circuit diagram for Hall input. It features a differential pair of transistors. Each input side has a diode connected to ground and a 50Ω resistor. The inputs are labeled 9, 11, and 13. The outputs are labeled 10, 12, and 14. A 1kΩ resistor is connected between the two transistor bases.</p>	 <p>Circuit diagram for Driver output. It shows a push-pull transistor stage with two transistors. Each transistor has a diode connected to ground. Terminals 27 and 28 are at the outputs, and terminals 2, 4, and 7 are at the inputs.</p>
Torque control input	Hall bias input
 <p>Circuit diagram for Torque control input. It shows an operational amplifier with two diodes connected to its non-inverting input (+) and two diodes connected to its inverting input (-). Each diode is in series with a 50Ω resistor. Terminals 21 and 22 are at the inputs.</p>	 <p>Circuit diagram for Hall bias input. It features a transistor circuit with two diodes connected to ground. A 50Ω resistor is connected to the input, labeled terminal 15. A 50kΩ resistor is connected to the output.</p>
Current detector	Start / Stop
 <p>Circuit diagram for Current detector. It shows a transistor circuit with two diodes connected to ground. A 50Ω resistor is connected to the input, labeled terminal 23. A 50kΩ resistor is connected to the output, and a 30kΩ resistor is connected to ground.</p>	 <p>Circuit diagram for Start / Stop. It shows a transistor circuit with two diodes connected to ground. A 50Ω resistor is connected to the input, labeled terminal 18. A 50kΩ resistor is connected to the output, and a 30kΩ resistor is connected to ground.</p>
Dir or FG output	FGS input
 <p>Circuit diagram for Dir or FG output. It shows a transistor circuit with two diodes connected to ground. A 20kΩ resistor is connected to VCC, and a 50Ω resistor is connected to the output, labeled terminals 20 and 24.</p>	 <p>Circuit diagram for FGS input. It shows a transistor circuit with two diodes connected to ground. A 50Ω resistor is connected to the input, labeled terminal 19. A 50kΩ resistor is connected to the output, and a 30kΩ resistor is connected to ground.</p>

Absolute Maximum Rating (Ta=25°C)

Parameter	Symbol	Value	Unit
Maximum supply voltage (Signal)	V _{CCmax}	7	V
Maximum supply voltage (Motor)	V _{Mmax}	18	V
Power dissipation	P _D	1.7 ^{note}	W
Maximum output current	I _{Omax}	1.3	A
Operating temperature range	T _{OPR}	-25 ~ +75	°C
Storage temperature range	T _{STG}	-55 ~ +150	°C

NOTE:

1. When mounted on 76.2mm × 114mm × 1.57mm PCB (Phenolic resin material)
2. Power dissipation is reduced 13.6 mW / °C for using above Ta=25°C
3. Do not exceed P_D and SOA (Safe operating area).

Power Dissipation Curve

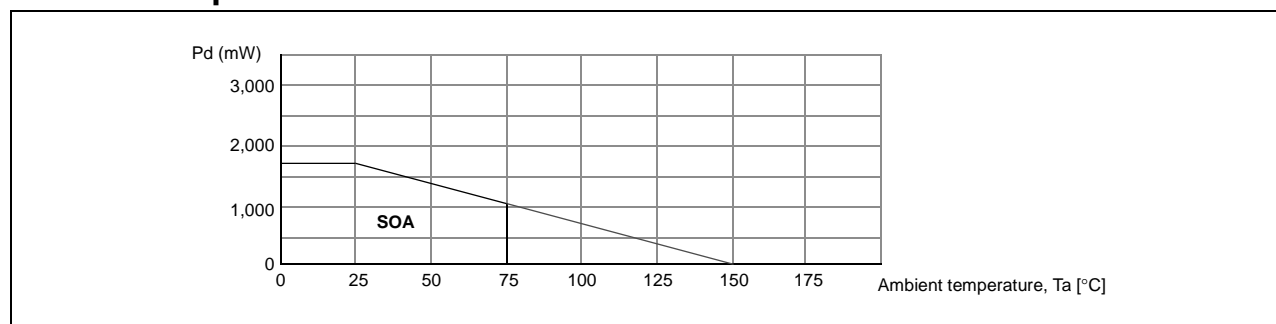

Recommended Operating Conditions (Ta=25°C)

Parameter	Symbol	Min.	Typ.	Max	Units
Supply voltage	V _{CC}	4.5	5	5.5	V
Motor supply voltage	V _M	3.0	12	15	V

Electrical Characteristics

(Unless otherwise specified, $T_a=25^{\circ}\text{C}$, $V_{CC}=5\text{V}$, $V_M=12\text{V}$)

Parameter	Symbol	Condition	Min.	Typ.	Max.	Units
Quiescent circuit current	I_{CC}	–	2	5	8	mA
START / STOP						
On voltage range	V_{SSon}	Output drive on	2.5	-	V_{CC}	V
Off voltage range	V_{SSoff}	Output driver off	0.0	-	1.0	V
HALL BIAS						
Hall bias voltage	V_{HB}	$I_{HB}=20\text{mA}$	0.4	1.0	1.8	V
HALL AMP						
Hall bias current	I_{HA}	–	-	0.5	2	μA
Common mode input range	V_{HAR}	–	1.5	-	4.0	V
Minimum input level	V_{INH}	–	100	-	-	mVpp
TORQUE CONTROL						
ECR input voltage range	E_{CR}	–	0.2	-	4.0	V
EC input voltage range	E_C	–	0.2	-	4.0	V
Offset voltage (-)	E_{Coff-}	$E_C=2.5\text{V}$	-80	-50	-20	mV
Offset voltage (+)	E_{Coff+}	$E_C=2.5\text{V}$	20	50	80	mV
EC input current	E_{Cin}	$E_C=2.5\text{V}$	-5	0.5	5	μA
ECR input current	E_{CRin}	$E_{CR}=2.5\text{V}$	-5	0.5	5	μA
In/output gain	G_{EC}	$E_{CR}=2.5\text{V}$, $R_{CS}=0.5\Omega$	0.41	0.51	0.61	A / V
FG						
FG output voltage (H)	V_{FGH}	$I_{FG}=-10\mu\text{A}$	3.0	-	V_{CC}	V
FG output voltage (L)	V_{FGL}	$I_{FG}=10\mu\text{A}$	-	-	0.5	V
Input voltage range		–	-	50	-	%
OUTPUT BLOCK						
Saturation voltage (upper TR)	V_{Oh}	$I_o=-300\text{mA}$	-	0.9	1.6	V
Saturation voltage (lower TR)	V_{Ol}	$I_o=300\text{mA}$	-	0.2	0.6	V
Torque limit current	I_{TL}	$R_{CS}=0.5\Omega$	560	700	840	mA
DIRECTION DETECTOR						
Dir output voltage (H)	V_{DIRh}	$I_{FG}=-10\mu\text{A}$	3.0	-	V_{CC}	V
Dir output voltage (L)	V_{DIRl}	$I_{FG}=10\mu\text{A}$	-	-	0.5	V
FG SELECTION						
3X frequency selection	V_{FG3X}	$FGS > 2.5\text{V}$	2.5	-	V_{CC}	V
1X frequency selection	V_{FG1X}	$FGS < 1.0\text{V}$	-	-	1.0	V
SHORT BRAKE						
On voltage range	V_{SBon}	-	2.5	-	V_{CC}	V
Off voltage range	V_{SBoff}	-	0	-	1.0	V

Electrical Characteristics (Continued)

Calculation of Gain & Torque Limit Current

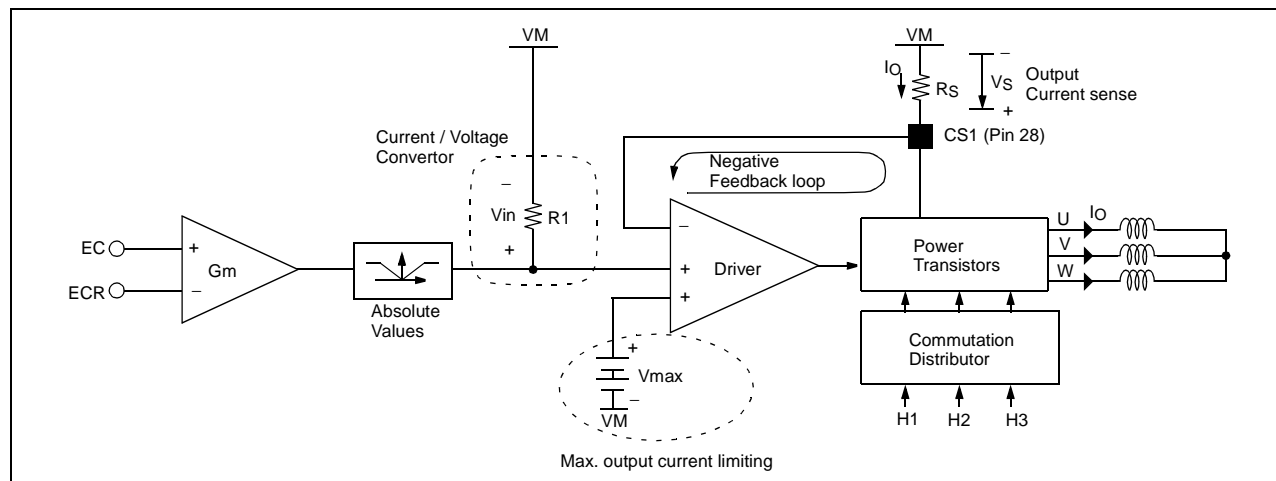

0.255 from GM times R1 is a fixed value within IC.

$$\text{Gain} = \frac{0.255}{R_S}$$

Vmax (see above block diagram) is setted to 350mV.

$$I_{tl}[\text{mA}] = \frac{V_{\text{max}}}{R_S} = \frac{350[\text{mV}]}{R_S}$$

Application Information

1. TORQUE & OUTPUT CURRENT CONTROL

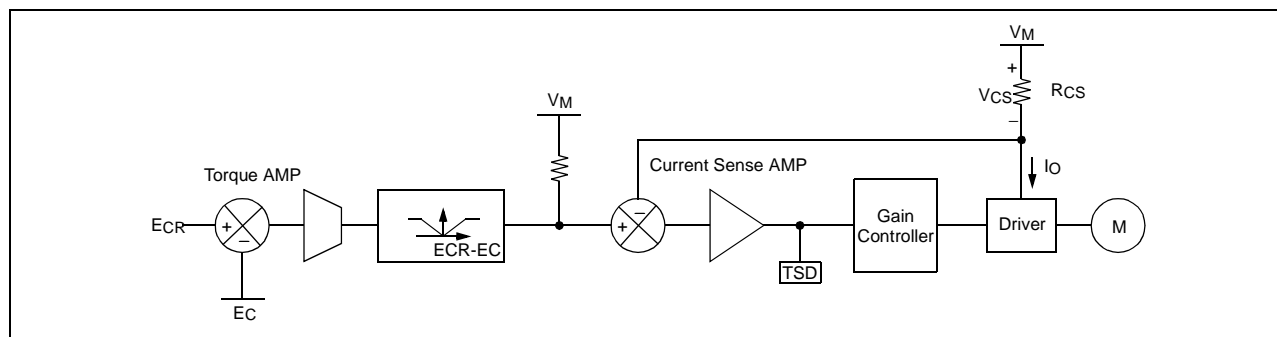

- By amplifying the voltage difference between EC and E_{cr} from servo IC, the torque sense amp produces the input (V_{AMP}) for the current sense amp.
- The output current (I_O) is converted into the voltage (V_{CS}) through the sense resistor (R_{CS}) and compared with the V_{AMP} . By the negative feedback loop, the sensed output voltage, V_{CS} is equal to the input V_{AMP} . Therefore, the output current (I_O) is linearly controlled by the input V_{AMP} .
- As a result, the signals, EC and E_{cr} can control the velocity of the Motor by controlling the output current (I_O) of the Driver.
- The range of the torque voltage is as shown below.

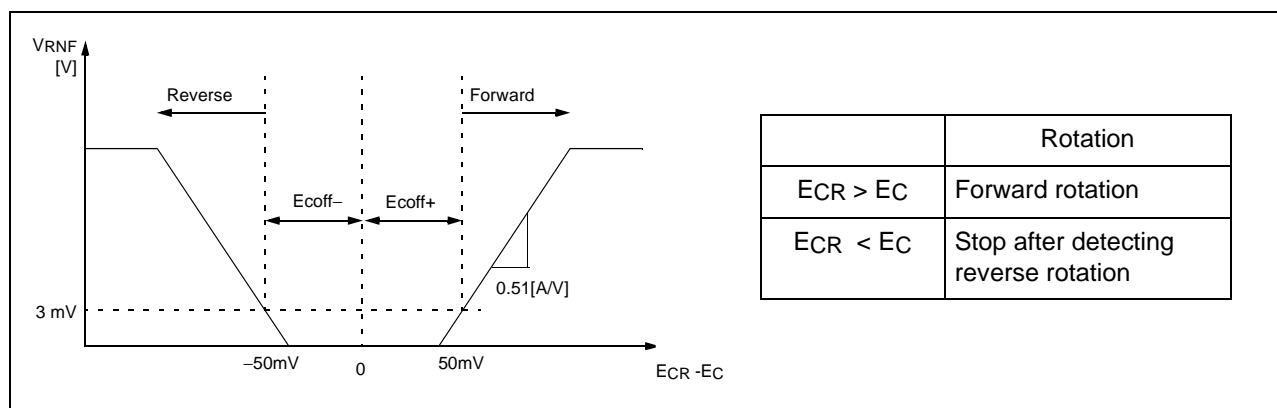

The input range of ECR , EC is $0.2V \sim 4V$.

2. SHORT BRAKE

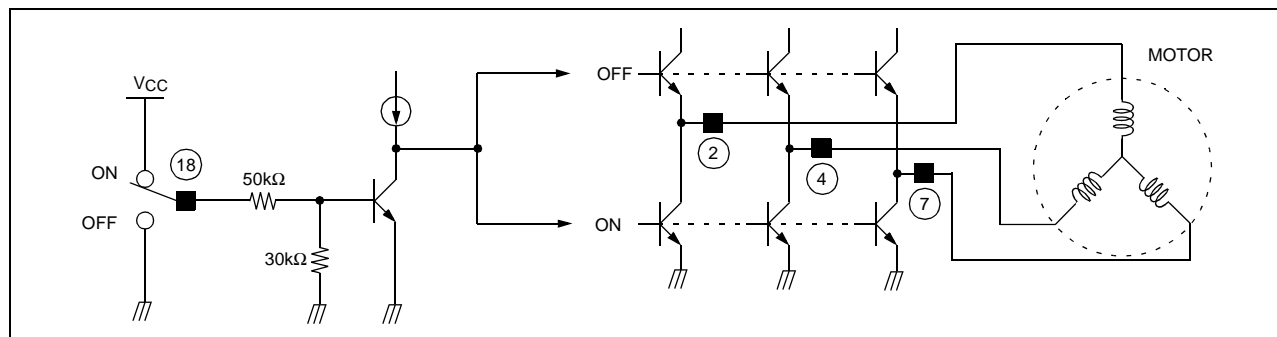

Pin # 18

Short brake

High	On
Low	Off

When the pick-up mechanism moves from the inner to the outer spindle of the CD, the brake function of the reverse voltage is commonly employed to decrease the rotating velocity of the spindle motor.

However, if the spindle motor rotates rapidly, the brake function of the reverse voltage may produce more heat at the Drive IC.

To remove this shortcoming and to enhance the braking efficiency, the short brake function is added to KA3011BD. When the short brake function is active, all upper power TRs turn off and all lower power TRs turn on, and the Motor slows down. But FG and DIR functions continue to operate normally.

3. POWER SAVE

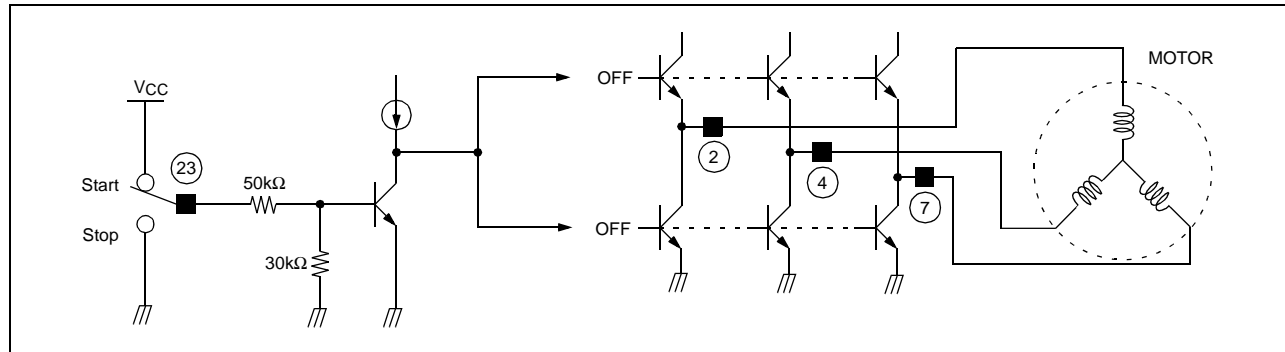

Pin # 23	Start/Stop
High	Operate
Low	Stop

When power save function is active, all power TRs turn off but FG and DIR functions continue to operate normally.

4. TSD (THERMAL SHUTDOWN)

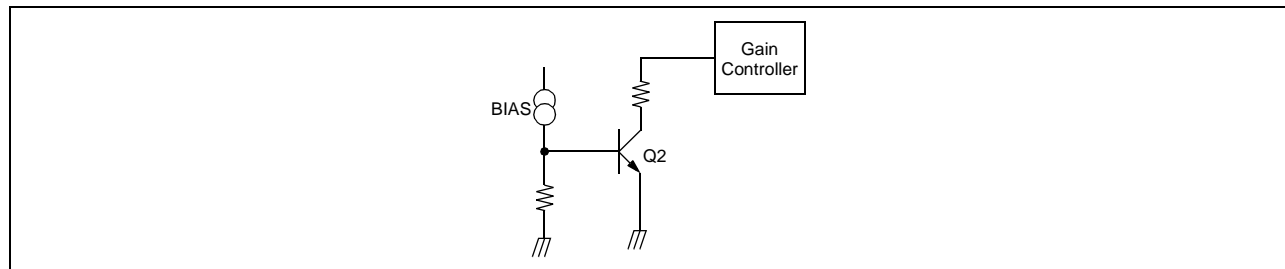

When the chip temperature rises above 175°C, the Q2 turns on and the output driver shuts down. When the chip temperature falls off to about 150°C, then the Q2 turns off and the driver operates normally. TSD has the temperature hysteresis of about 25°C.

5. ROTATIONAL DIRECTION DETECTION

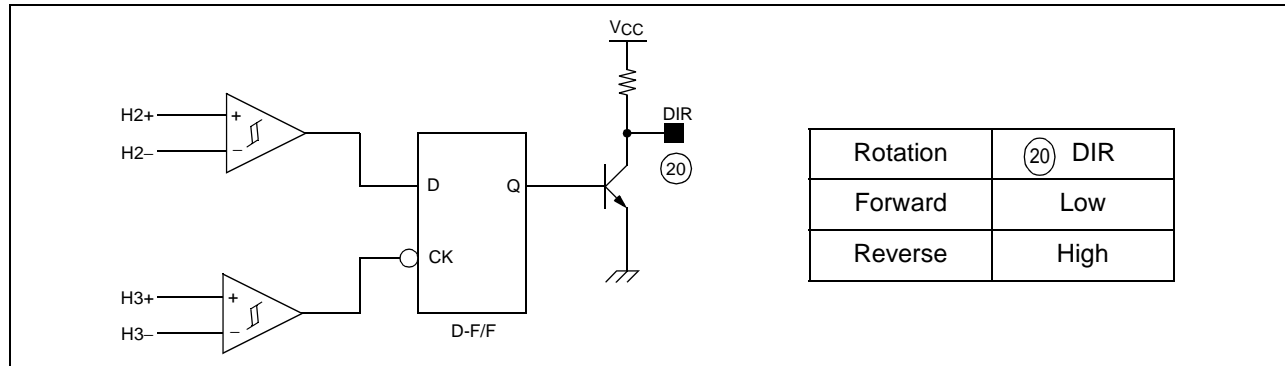

- The forward and the reverse rotations of the CD are detected by the D-F/F and the truth table is shown above.
- The rotational direction of the CD can be explained by the output waveform of the hall sensors. The three outputs of hall sensors be H1, H2 and H3 respectively.
When the spindle rotates in reverse direction, the hall sensor output waveforms are shown in Fig.(a). The phases order are in H1→H2→H3 with a 120° phase difference.

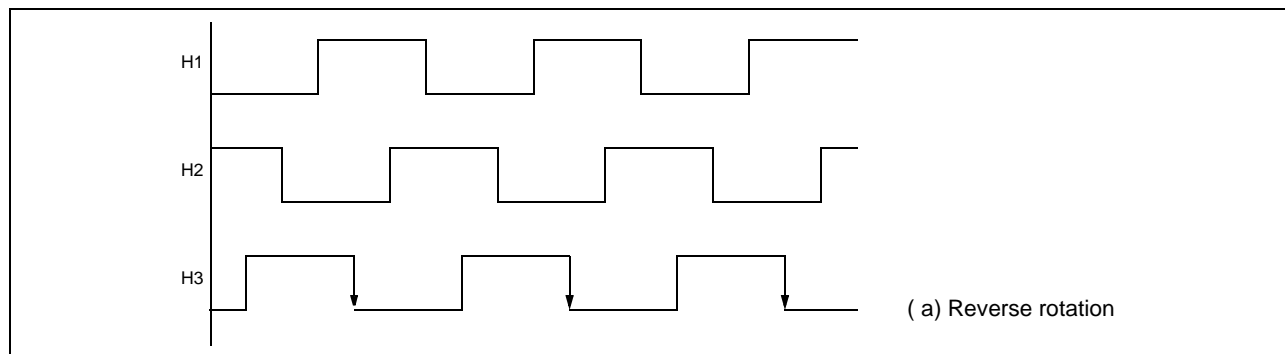

On the other hand, if the spindle rotates in forward rotation, the phase relationship is H3→H2→H1 as shown in Fig.(b).

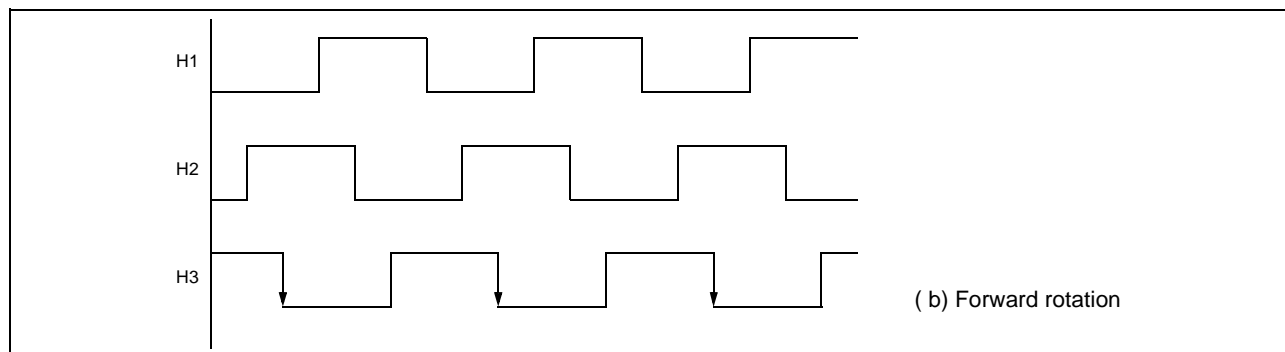

The output of the rotational direction detector is low, when the spindle rotates forward, and high in the reverse rotation.

6. REVERSE ROTATION PREVENTION

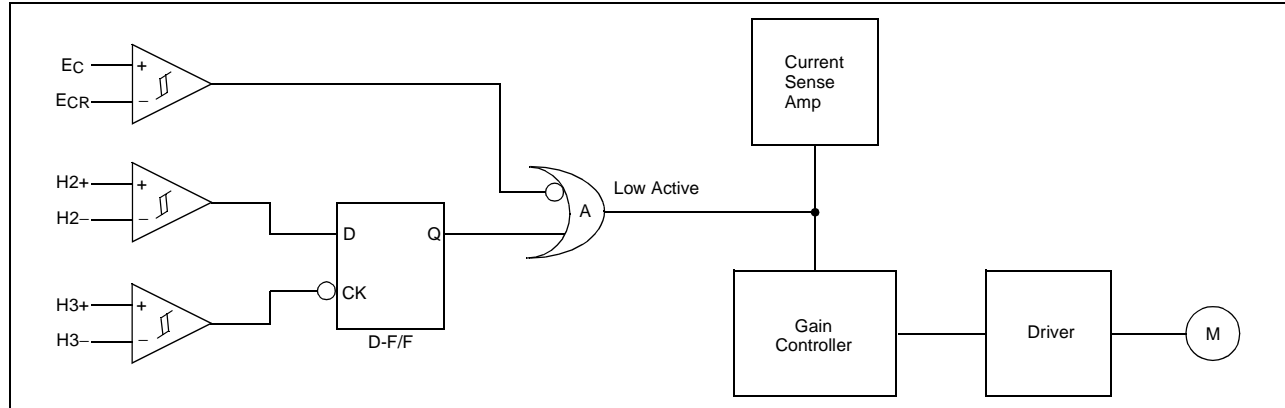

- When the output of the OR Gate, A is LOW, it steers all the output current of the current sense Amp to the Gain Controller zero. The output current of the Driver becomes zero and the motor stops.
- As in the state of the forward rotation, the D-F/F output, Q is HIGH and the motor rotates normally. At this state, if the control input is changed such that $EC > ECR$, then the motor rotates slowly by the reverse commutation in the Driver. When the motor rotates in reverse direction, the D-F/F output becomes Low and the OR Gate output, becomes LOW. This prevents the motor from rotating in reverse direction. The operation principle is shown in the table and the flow chart.

Rotation	H2	H3	D-F/F (Q)	Reverse rotation preventer	
				$EC < ECR$	$EC > ECR$
Forward	H	H→L	H	Forward	-
Reverse	L	H→L	L	-	Brake and stop

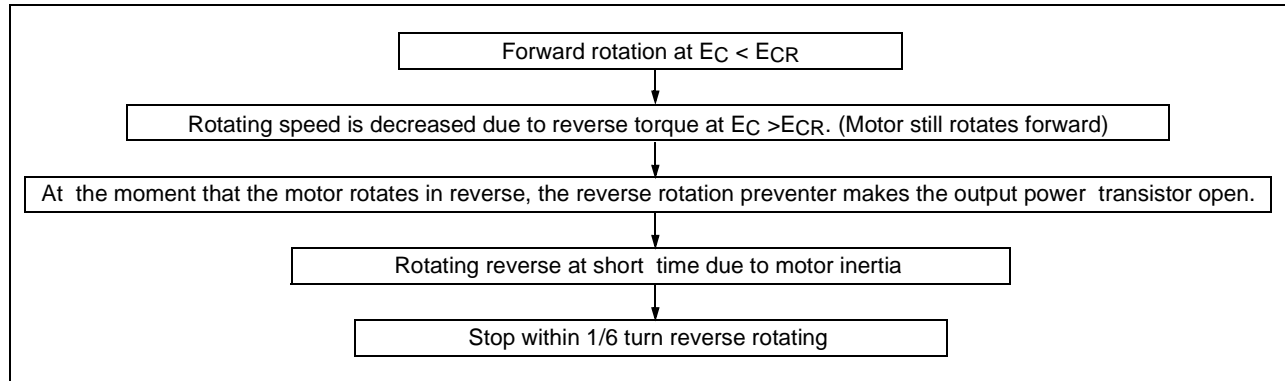

7. FG OUTPUT

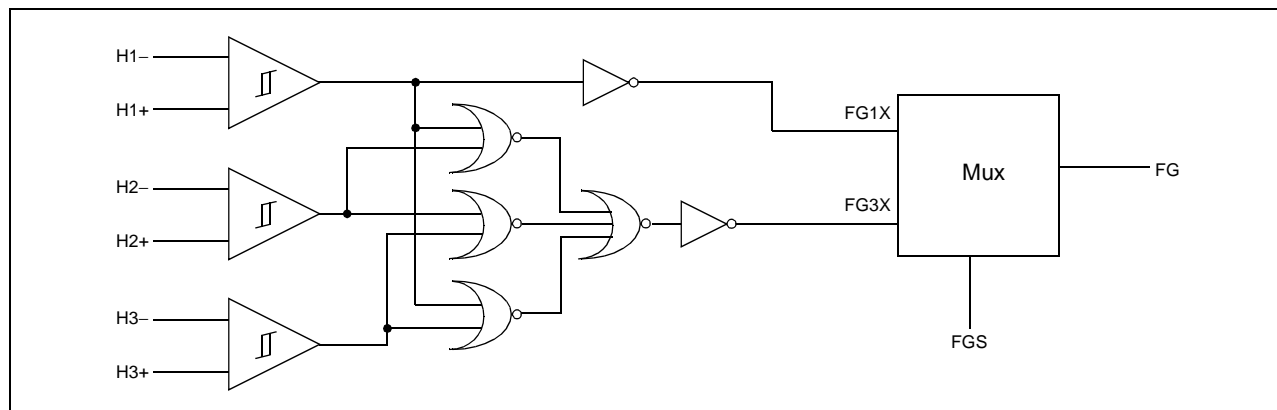

FGS	FG
GND or Open	FG1X (1X hall frequency)
VCC	FG3X (3X hall frequency)

8. HALL SENSOR CONNECTION

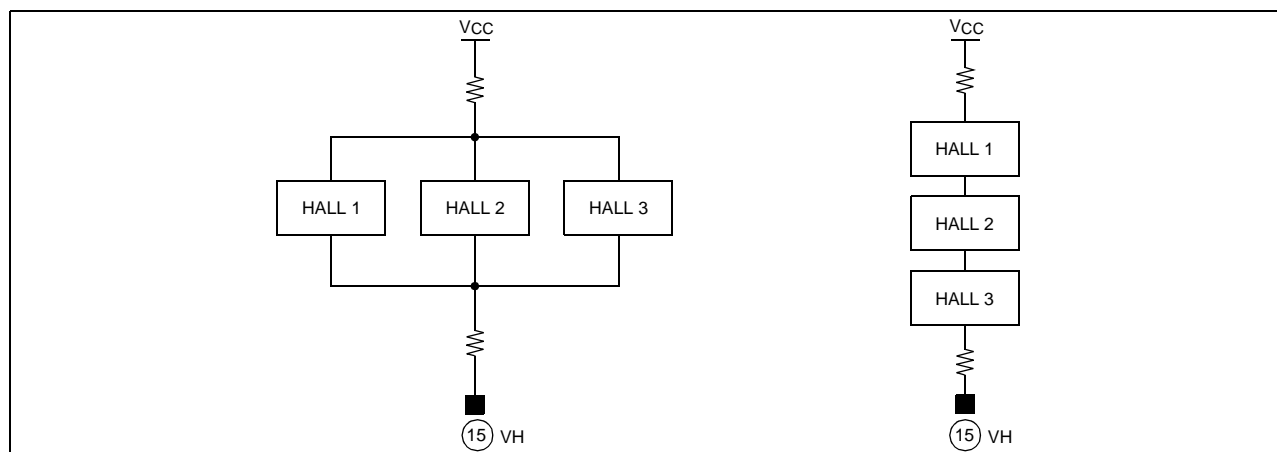

9. Connect a by-pass capacitor, 0.1mF between the supply voltage source.

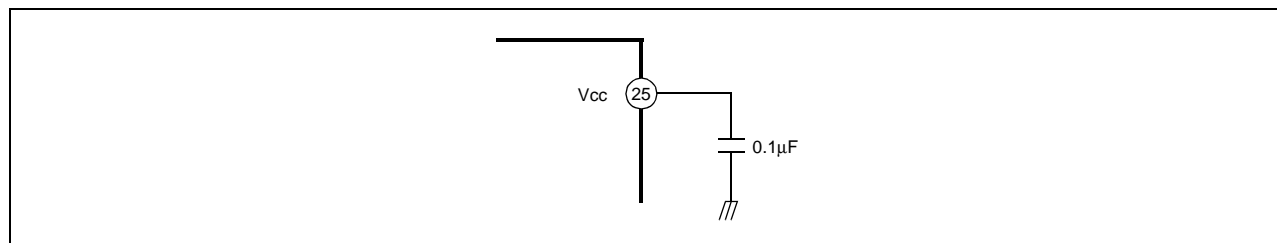

10. The heat radiation fin is connected to the internal GND of the package.
Connect that fin to the external GND.

11. INPUT-OUTPUT TIMING CHART

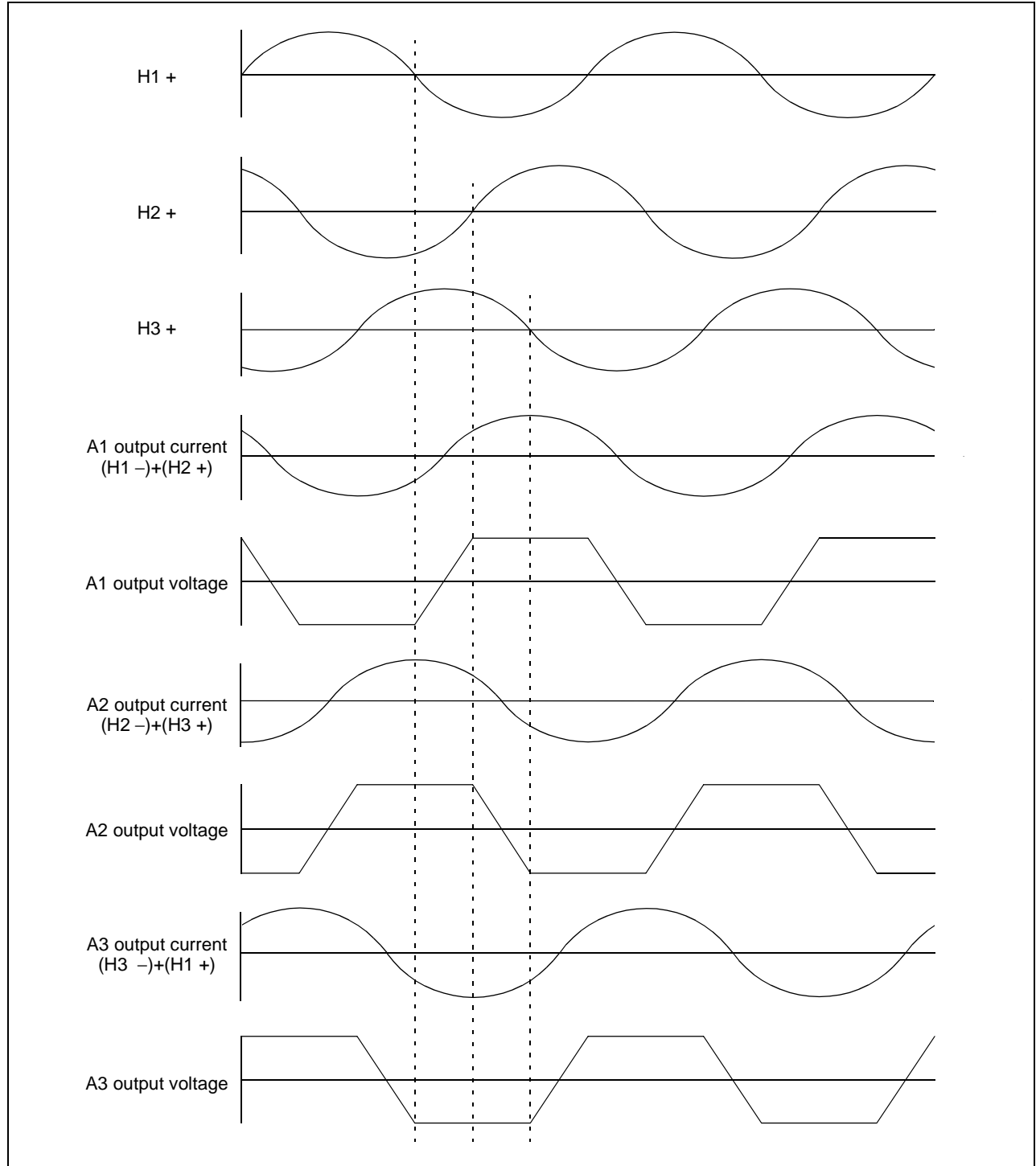

Test Circuits

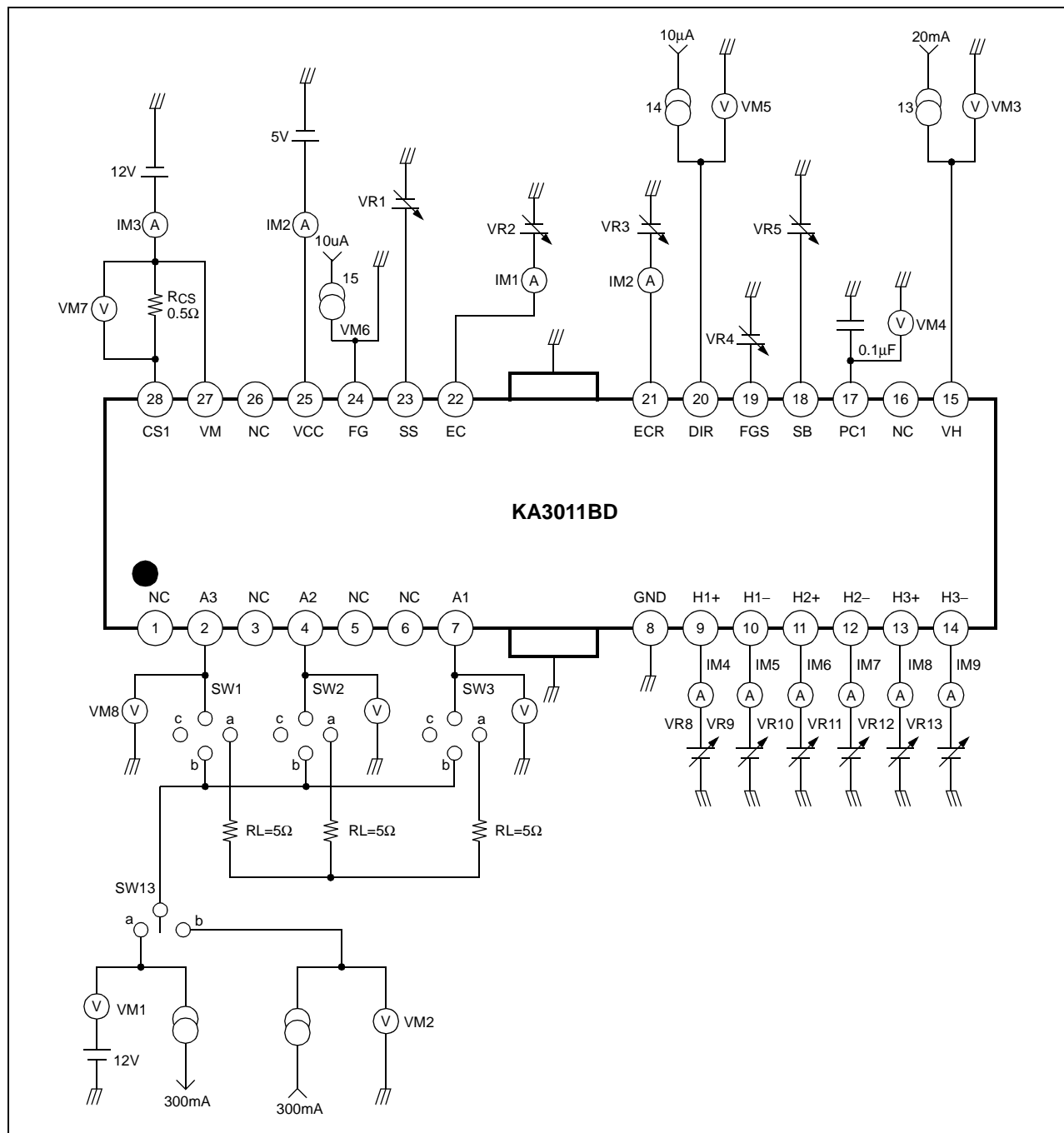

Typical Application Circuits

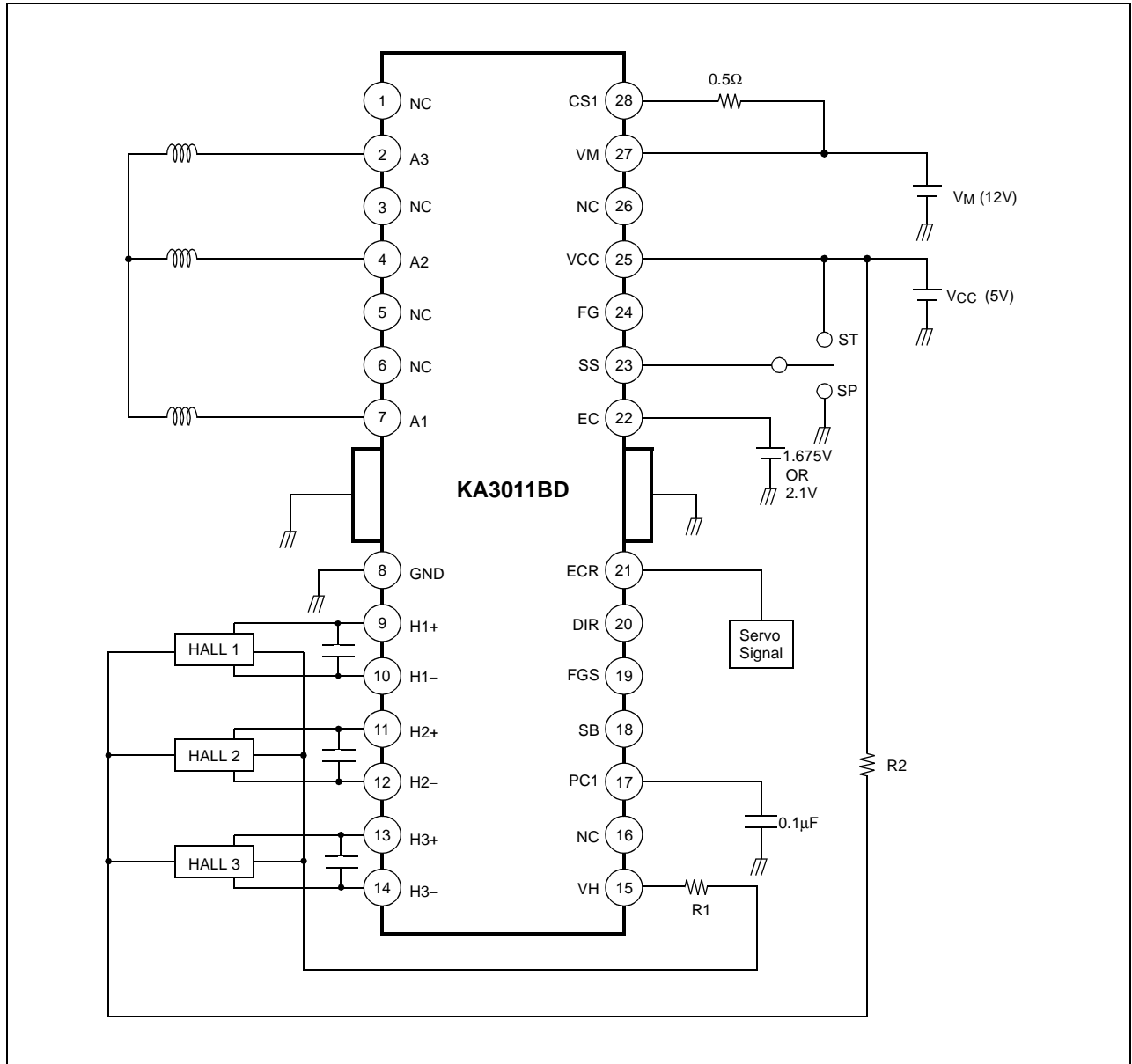

DISCLAIMER

FAIRCHILD SEMICONDUCTOR RESERVES THE RIGHT TO MAKE CHANGES WITHOUT FURTHER NOTICE TO ANY PRODUCTS HEREIN TO IMPROVE RELIABILITY, FUNCTION OR DESIGN. FAIRCHILD DOES NOT ASSUME ANY LIABILITY ARISING OUT OF THE APPLICATION OR USE OF ANY PRODUCT OR CIRCUIT DESCRIBED HEREIN; NEITHER DOES IT CONVEY ANY LICENSE UNDER ITS PATENT RIGHTS, NOR THE RIGHTS OF OTHERS.

LIFE SUPPORT POLICY

FAIRCHILD'S PRODUCTS ARE NOT AUTHORIZED FOR USE AS CRITICAL COMPONENTS IN LIFE SUPPORT DEVICES OR SYSTEMS WITHOUT THE EXPRESS WRITTEN APPROVAL OF THE PRESIDENT OF FAIRCHILD SEMICONDUCTOR INTERNATIONAL. As used herein:

1. Life support devices or systems are devices or systems which, (a) are intended for surgical implant into the body, or (b) support or sustain life, and (c) whose failure to perform when properly used in accordance with instructions for use provided in the labeling, can be reasonably expected to result in a significant injury of the user.
2. A critical component in any component of a life support device or system whose failure to perform can be reasonably expected to cause the failure of the life support device or system, or to affect its safety or effectiveness.



LittleDiode supplies new, hard to find or obsolete electronic components and semiconductors all over the world.

With over two million different components listed you are sure to find the part you need.

Feel free to visit us today at our online store:

LittleDiode.com

Looking forward to providing you with the best possible service.