

KA3084D

2-Phase BLDC Motor Driver

Features

- Drives the BLDC motor using 2 hall sensors.
- 2-phase, full-wave drive method
- Built-in thermal shutdown (TSD) circuit
- Controls the motor speed through voltage
- Built-in bandgap circuit
- Built-in frequency Generator (FG) & Phase Generator (PG) amplifier & comparator.

Description

The KA3084D is a monolithic integrated circuit, and it is suitable for drum motor driver of VCR system.

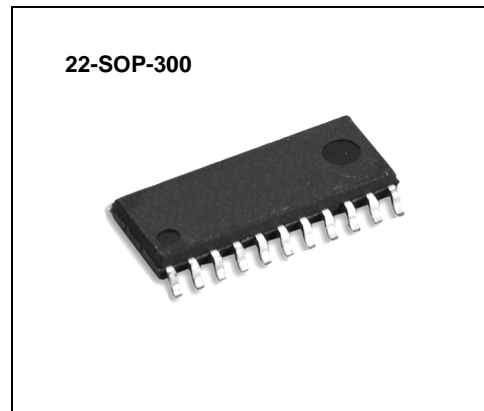

Target Applications

- Video cassette recorder(VCR) cylinder (drum) motor
- Other 2-phase BLDC motor

Ordering Information

Device	Package	Operating Temp.
KA3084D	22-SOP-300	-25°C ~ +75°C
KA3084DTF	22-SOP-300	-25°C ~ +75°C

Pin Assignments

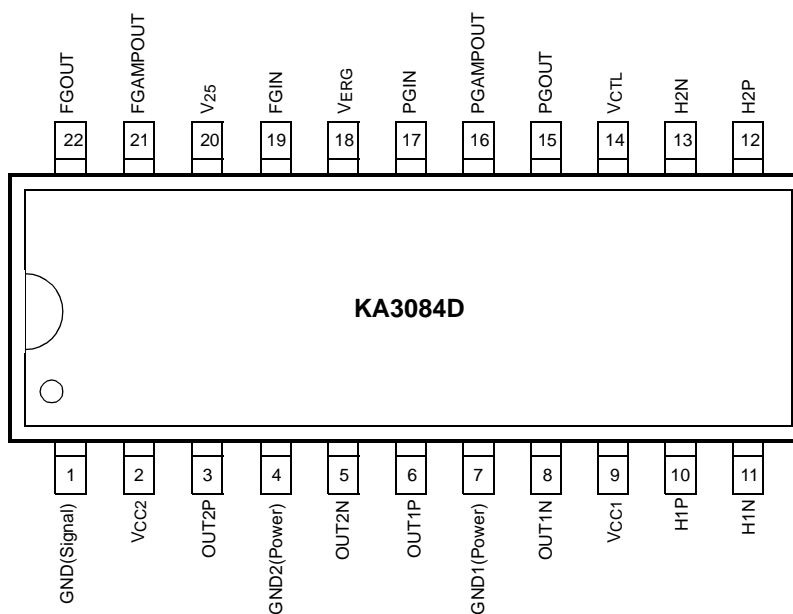

Pin Definitions

Pine Number	Pin Name	I/O	Pin Function Description
1	GND (Signal)	-	Ground (Signal)
2	VCC2	-	Power supply 2
3	OUT2P	O	Output drive 2(P)
4	GND2 (Power)	-	Power ground 2
5	OUT2N	O	Output drive 2(N)
6	OUT1P	O	Power supply 1(P)
7	GND1 (Power)	-	Power ground 1
8	OUT1N	O	Output drive 1(N)
9	VCC1	-	Power supply 1
10	H1P	I	Hall signal input 1P
11	H1N	I	Hall signal input 1N
12	H2P	I	Hall signal input 2P
13	H2N	I	Hall signal input 2N
14	VCTL	I	Voltage control (Motor speed control)
15	PGOUT	O	Phase generator output
16	PGAMPOUT	O	Phase generator amp. output
17	PGIN	I	Phase generator input
18	VREG	O	Regurated voltage
19	FGIN	I	Frequency generator input
20	V ₂₅	I/O	Reference voltage
21	FGAMPOUT	O	Frequency generator amp. output
22	FGOUT	O	Frequency generator output

Internal Block Diagram

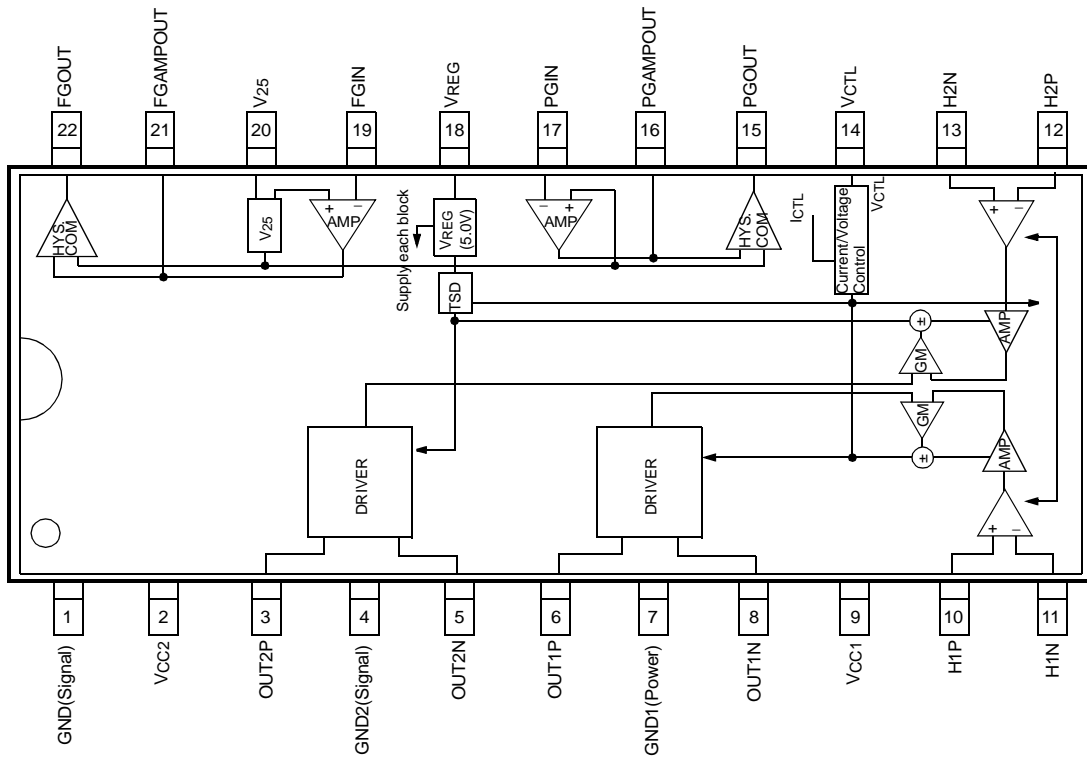

Equivalent Circuits

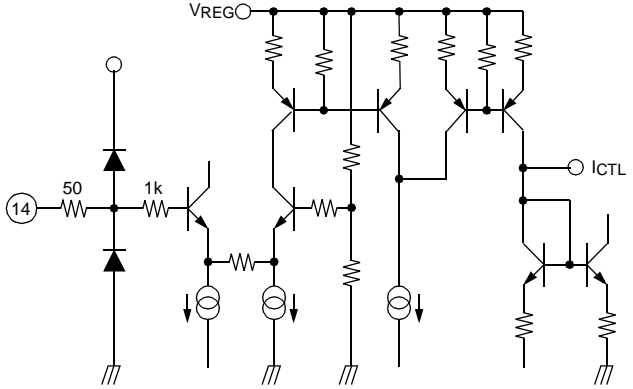
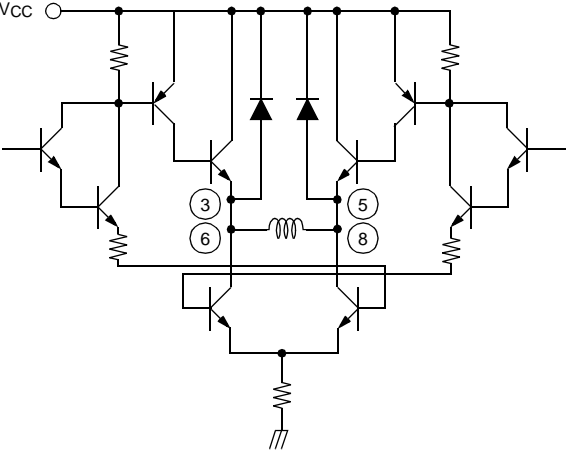
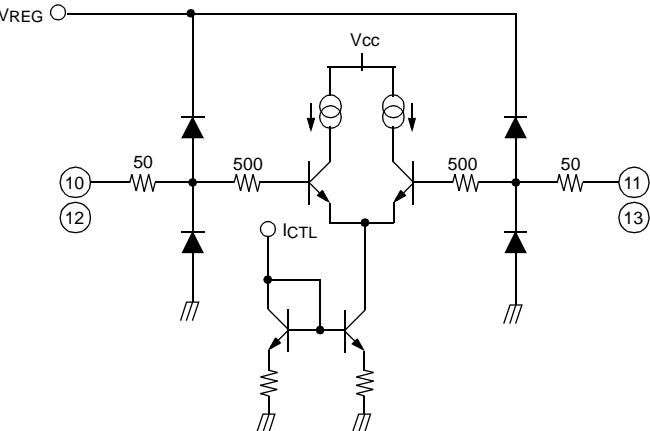
Description	Pin No.	Internal circuit
VCTL	14	
Motor output	3, 5, 6, 8	
Hall input	10, 11, 12, 13	

Equivalent Circuits (Continued)

Description	Pin No.	Internal circuit
PG, FG amplifier	16, 17 19, 21	
PG, FG hysteresis amplifier	3, 5, 6, 8	

Absolute Maximum Ratings (Ta=25°C)

Parameter	Symbol	Value	Unit	Remark
Supply voltage	VCCmax	18	V	-
Maxium output current	IOmax	1.0 ^{note1}	A	-
VREG output current	IREGmax	30	mA	-
Power dissipation	Pd	1 ^{note2}	W	No heat sink
Operating temperature	TOPR	-25 ~ +75	°C	-
Storage temperature	TSTG	-45 ~ +125	°C	-

Notes:

- Duty 1 / 100, pulse width 500µs
- 1) When mounted on glass epoxy PCB (76.2 × 114 × 1.57mm)
2) Power dissipation reduces 8.0mW / °C for using above Ta=25°C. (Without heat-sink)
3) Do not exceed Pd and SOA(Safe Operating Area).

Power Dissipation Curve

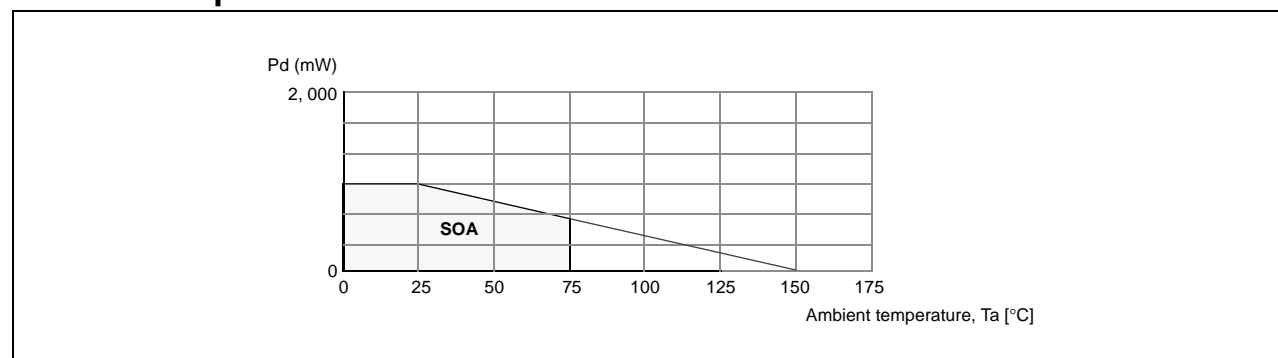

Recommended Operating Conditions (Ta = 25°C)

Parameter	Symbol	Min.	Typ.	Max	Units
Operating supply voltage	VCC	8	12	16	V

Electrical Characteristics

($T_a=25^\circ\text{C}$, $V_{CC}=12\text{V}$, unless otherwise specified)

Parameter	Symbol	Condition	Min.	Typ.	Max.	Units
FULL CIRCUIT						
Quiescent current	I_Q	$V_{CC}=12\text{V}$	-	8.5	13	mA
VOLTAGE REGULATOR						
Regulated voltage	V_{REG}	$V_{CC}=12\text{V}$	4.6	5.0	5.4	V
Regulated voltage	V_{REG}	$V_{CC}=12\text{V}$, $I_{REG}=-20\text{mA}$	4.6	5.0	5.4	V
HALL INPUT						
Hall minimum input level ^{note}	V_{INH}	-	50	-	-	mVp-p
Hall bias current	I_{BH}	$V_{CTL}=2.0\text{V}$, Hall=2.5V	-	0.25	2.0	μA
OUTPUT DIRVE						
Output saturation voltage (Upper)	V_{SU}	$V_{CTL}=4.5\text{V}$	-	1.3	2.0	V
Output saturation voltage (Lower)	V_{SL}	$V_{CTL}=4.5\text{V}$	-	2.0	2.0	V
Output current A	I_{OUTA}	$V_{H1P}=2.6\text{V}$ $V_{H1N}=2.4\text{V}$, $V_{CTL}=3.5\text{V}$	500	700	900	mA
Output current B	I_{OUTB}	$V_{H2P}=2.6\text{V}$ $V_{H2N}=2.4\text{V}$, $V_{CTL}=2.5\text{V}$	500	700	900	mA
VOLTAGE CONTROL						
V_{CTL} reference voltage ^{note}	V_{25}	$0.48 \times V_{REG}$	2.0	2.3	2.5	V
V_{CTL} input range ^{note}	V_{CTL}	-	0	-	V_{REG}	V
V_{CTL} offset range	V_{OFF}	$V_{CTL}=0 \sim V_{CTL}$	-150	0	+150	mV
V_{CTL} input bias current	I_{VCTL}	$V_{CTL}=2.5\text{V}$	-	1.0	6.0	μA
Voltage control gain	G_M	$V_{CTL}=2.8\text{V}$, 3.3V $\Delta I_O / \Delta V_{CTL}$ $V_{H1P}=2.6\text{V}$, $V_{H1N}=2.4\text{V}$	0.38	0.55	0.64	A / V

The graph plots output current I_O against V_{CTL} . The x-axis is labeled V_{CTL} and the y-axis is labeled I_O . A line starts at a point on the x-axis labeled $0.48 \times V_{REG} \text{ (TYP)}$. From this point, the line rises linearly with a slope of 0.55A/V (TYP) . After reaching a certain current level, the line becomes horizontal, indicating that the output current is constant for higher V_{CTL} values.

Notes:

The note in the chart means items calculated and approved in design not the items proven by actual test result.

Electrical Characteristics (Continued)

(Ta=25°C, VCC=12V, unless otherwise specified)

Parameter	Symbol	Condition	Min.	Typ.	Max.	Units
FULL CIRCUIT						
Shutdown temperature ^{note}	TSD	-	130	160	-	°C
Temperature hysteresis ^{note}	THYS	-	-	30	-	°C
FG / PG AMP						
Input offset voltage	VOFS	-	-	0	± 8	mV
Input current	IAMPIN	VIN=2.5V	-	0.2	2.0	μA
Open loop gain ^{note}	GA	VCC=12V, Signal=500Hz	65	70	-	dB
Output high voltage	VOHA	VIN=2.0V	VREG -1.48	VREG -0.74	-	V
Output low voltage	VOLA	VIN=2.7	-	0.85	1.45	V
COMPARATOR (HYSTERESIS)						
Hysteresis level	VHYS	-	±130	±165	±200	mV
Output low voltage	VOLHYS	VIN=2.0V	-	0.12	0.32	V
Output pull-up resistance	VBHYS	-	7.0	10	13	kΩ

Notes:

The note in the chart means items calculated and approved in design not the items proven by actual test result.

Application Informations

1. A DIAGRAM SUMMARIZING THE ENTIRE SYSTEM

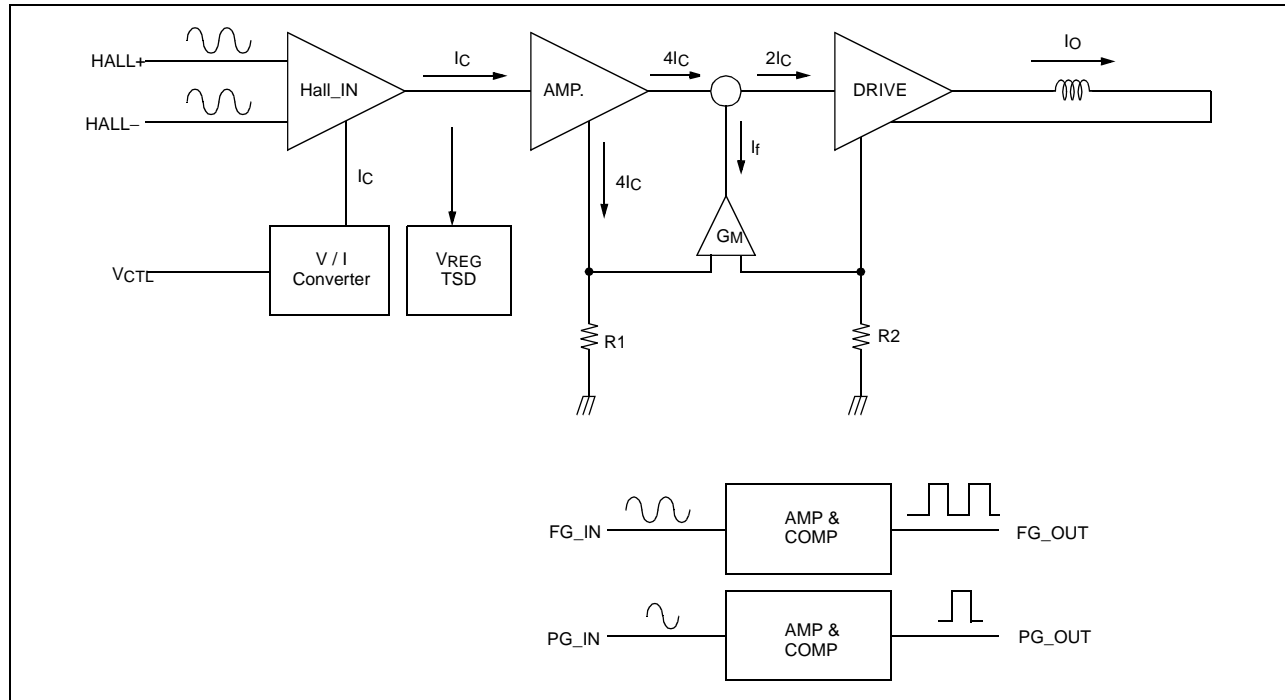

Figure 1.

Figure 1 is a conceptual diagram of the KA3084D. It shows that it turns on or off depending on the signal of the hall sensor used for sensing the rotor position of motor.

The AMP, GM (Feedback) and output blocks are circuits used to determine current gain of KA3084D.

Furthermore, HallIN represents the hall signal switch.

It supplies stable bias to each VREG block. The TSD block is a thermal shutdown circuit that protects the IC during an high temperature inside the IC.

Moreover, FG. and PG. blocks output individual signals generated in the motor using the amplifier and comparator.

These signals transmit motor speed and position data to controller of external servo etc. for their control.

2. CURRENT CONTROL

Figure 2 simplifies figure 1.

The supplied I_O current drives the motor and the I_c current controls the motor speed.

Figure 3 is a graph of I_{CTL} vs. I_O .

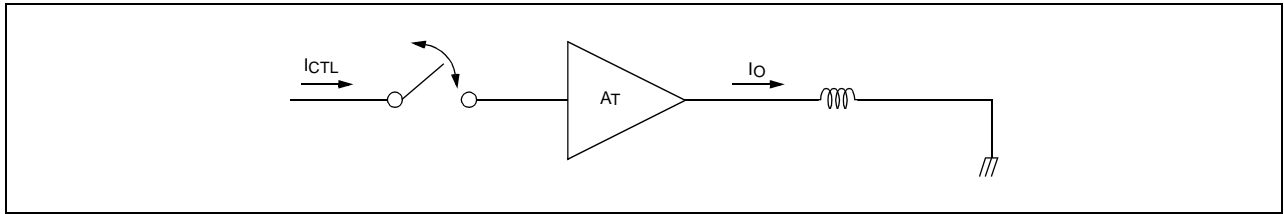

Figure 2.

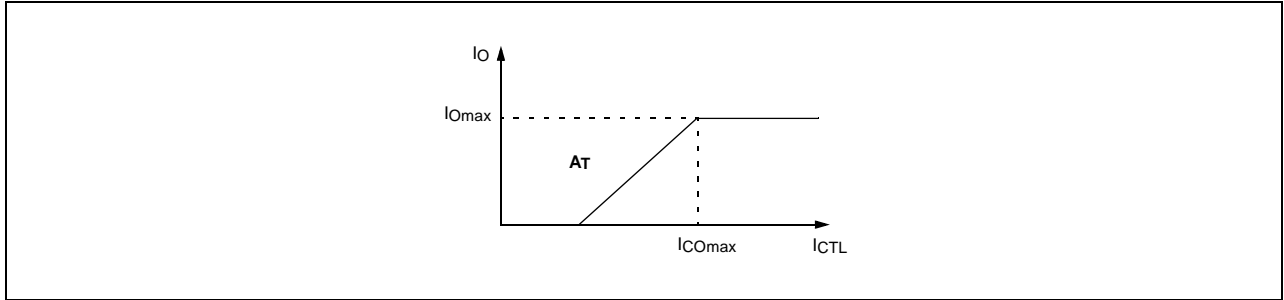

Figure 3.

3. VOLTAGE CONTROL

Even though KA3084D command uses I_c to control the magnitude of I_O , it can also use voltage. KA3084D mainly uses voltage control and has option to use current control.

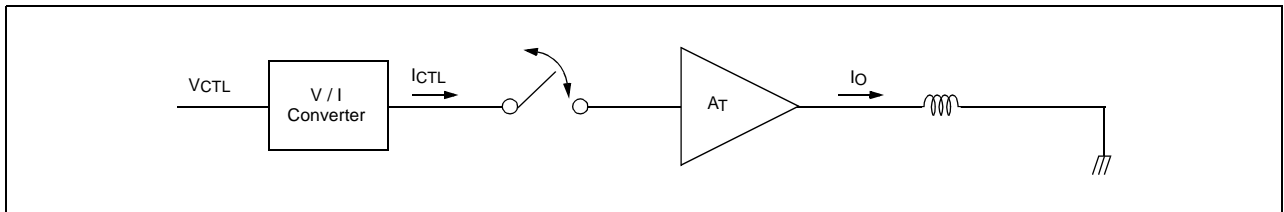

Figure 4.

Figure 4 shows the principle of the voltage control.

The V_{CTL} is the motor speed control voltage, and the I_{CTL} is converted to current through the V / I converter.

Figure 5 shows the graph of V_{CTL} vs. I_O .

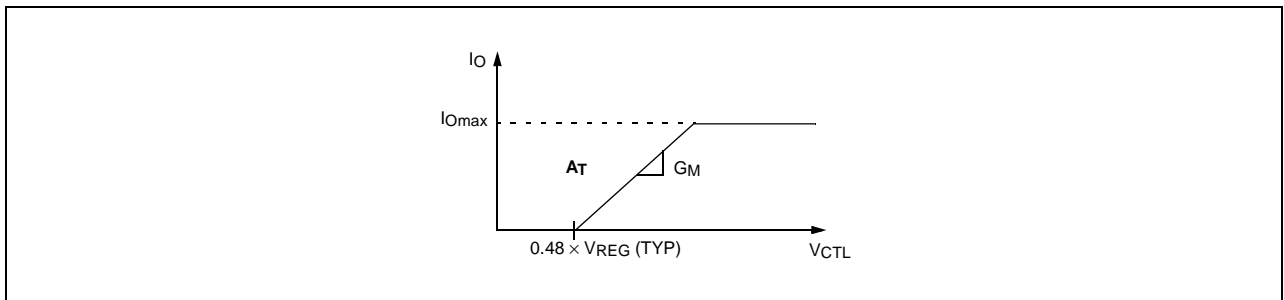
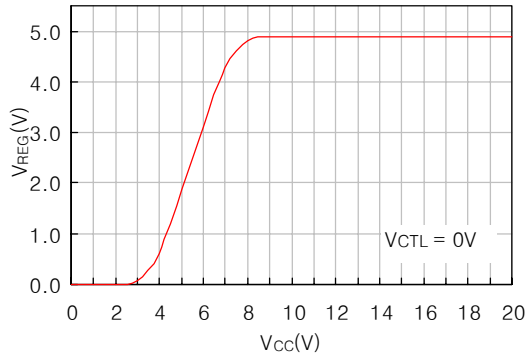
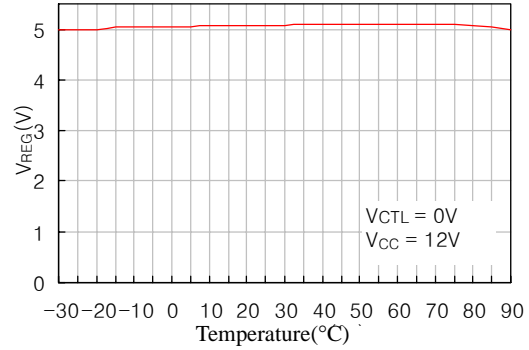

Figure 5.

Typical Performance Characteristics



1. V_{CC} vs V_{REG}



2. Temp. vs V_{REG}

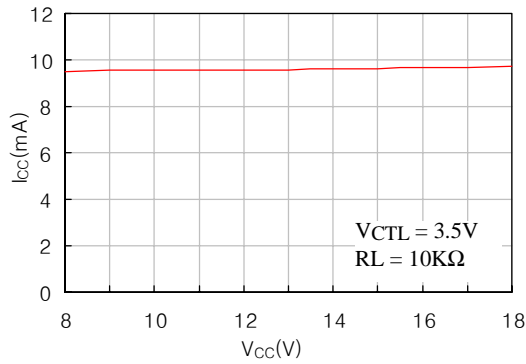

3. V_{CC} vs I_{CC}

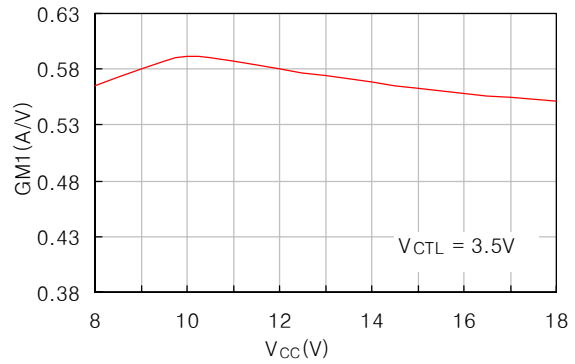

4. V_{CC} vs $GM1$

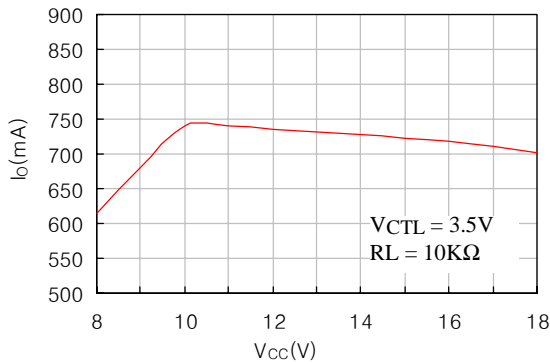

5. V_{CC} vs I_{OA}

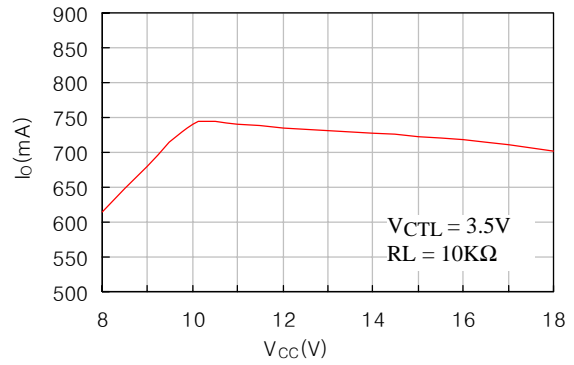

6. V_{CC} vs I_{OB}

Test Circuits

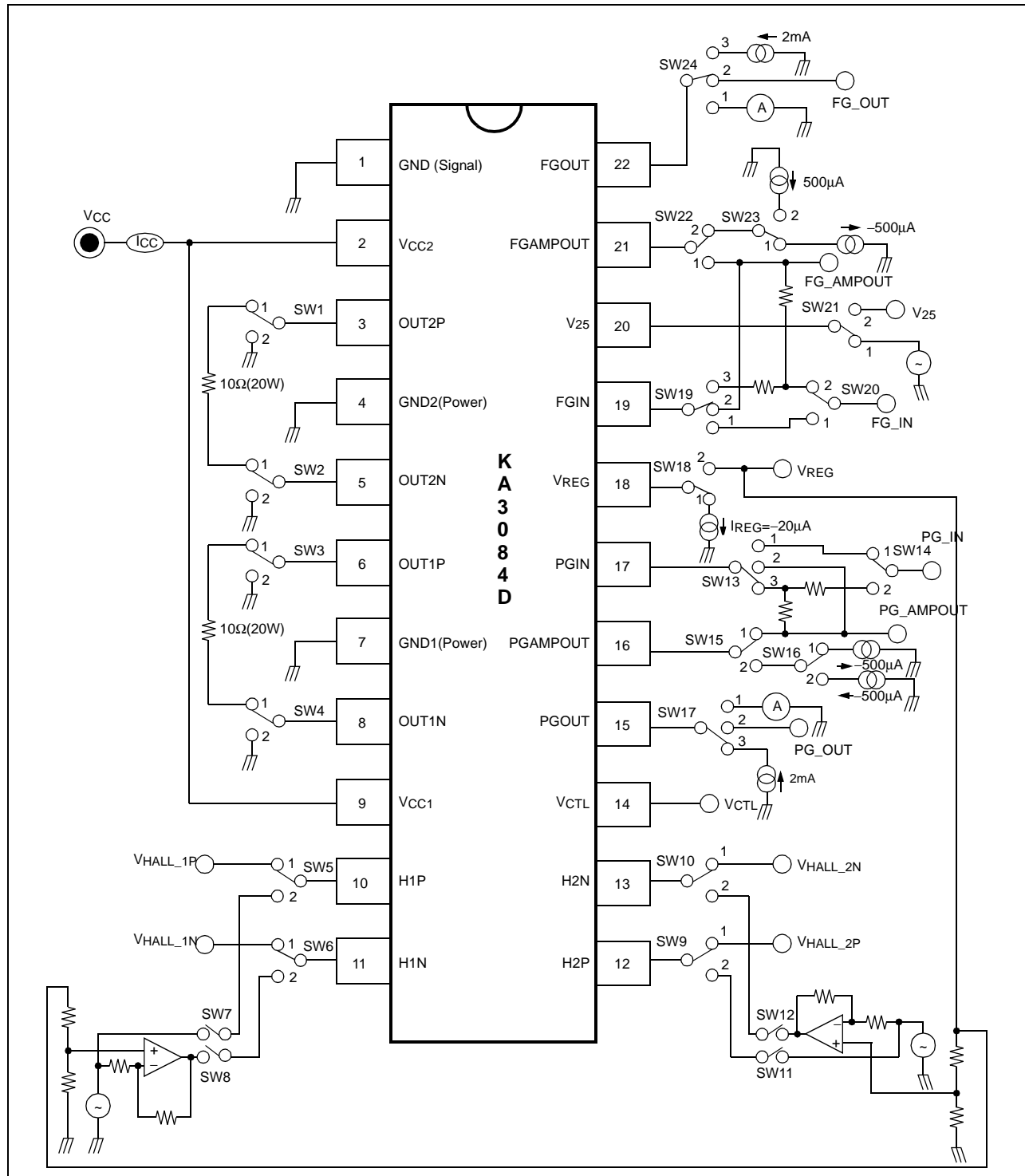

Typical Application Circuits

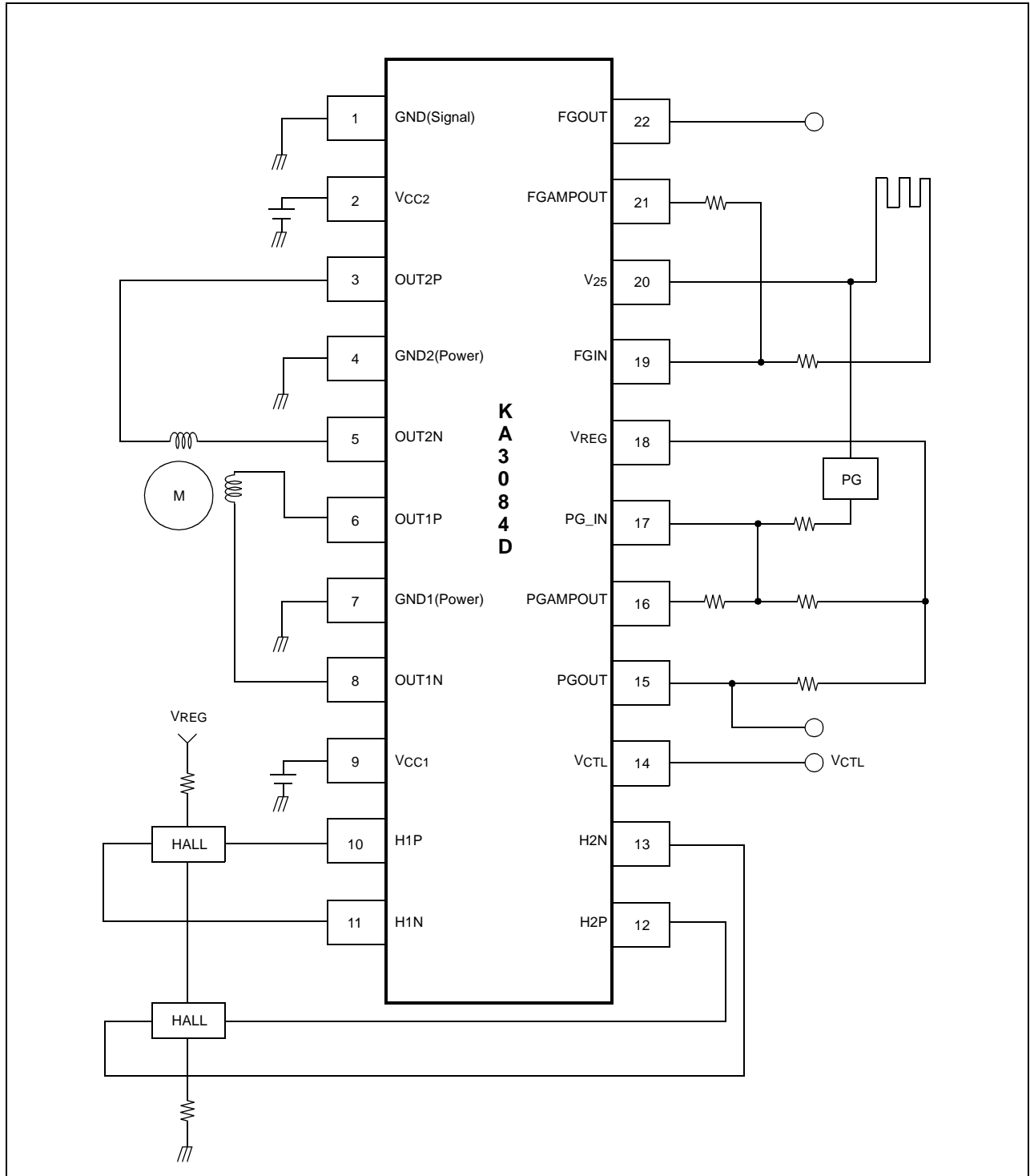

DISCLAIMER

FAIRCHILD SEMICONDUCTOR RESERVES THE RIGHT TO MAKE CHANGES WITHOUT FURTHER NOTICE TO ANY PRODUCTS HEREIN TO IMPROVE RELIABILITY, FUNCTION OR DESIGN. FAIRCHILD DOES NOT ASSUME ANY LIABILITY ARISING OUT OF THE APPLICATION OR USE OF ANY PRODUCT OR CIRCUIT DESCRIBED HEREIN; NEITHER DOES IT CONVEY ANY LICENSE UNDER ITS PATENT RIGHTS, NOR THE RIGHTS OF OTHERS.

LIFE SUPPORT POLICY

FAIRCHILD'S PRODUCTS ARE NOT AUTHORIZED FOR USE AS CRITICAL COMPONENTS IN LIFE SUPPORT DEVICES OR SYSTEMS WITHOUT THE EXPRESS WRITTEN APPROVAL OF THE PRESIDENT OF FAIRCHILD SEMICONDUCTOR INTERNATIONAL. As used herein:

1. Life support devices or systems are devices or systems which, (a) are intended for surgical implant into the body, or (b) support or sustain life, and (c) whose failure to perform when properly used in accordance with instructions for use provided in the labeling, can be reasonably expected to result in a significant injury of the user.
2. A critical component in any component of a life support device or system whose failure to perform can be reasonably expected to cause the failure of the life support device or system, or to affect its safety or effectiveness.



LittleDiode supplies new, hard to find or obsolete electronic components and semiconductors all over the world.

With over two million different components listed you are sure to find the part you need.

Feel free to visit us today at our online store:

LittleDiode.com

Looking forward to providing you with the best possible service.