

# KA3842B/KA3843B/KA3844B/KA3845B

## SMPS Controller

### Features

- Low Start Up Current
- Maximum Duty Clamp
- UVLO With Hysteresis
- Operating Frequency Up To 500KHz

### Description

The KA3842B/KA3843B/KA3844B/KA3845B are fixed frequency current-mode PWM controller. They are specially designed for Off - Line and DC-to-DC converter applications with minimum external components. These integrated circuits feature a trimmed oscillator for precise duty cycle control, a temperature compensated reference, high gain error amplifier, current sensing comparator, and a high current totempole output. Ideally suited for driving a power MOSFET. Protection circuitry includes built in under-voltage lockout and current limiting. The KA3842B and KA3844B have UVLO thresholds of 16V (on) and 10V (off). The KA3843B and KA3845B are 8.5V (on) and 7.9V (off). The KA3842B and KA3843B can operate within 100% duty cycle. The KA3844B and KA3845B can operate with 50% duty cycle.

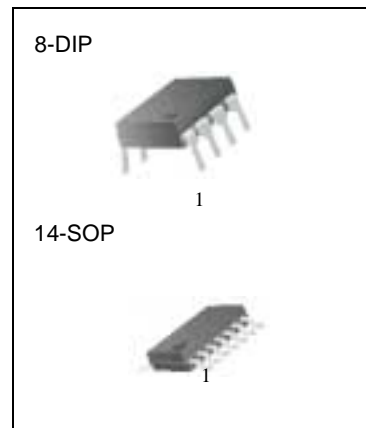

## Internal Block Diagram

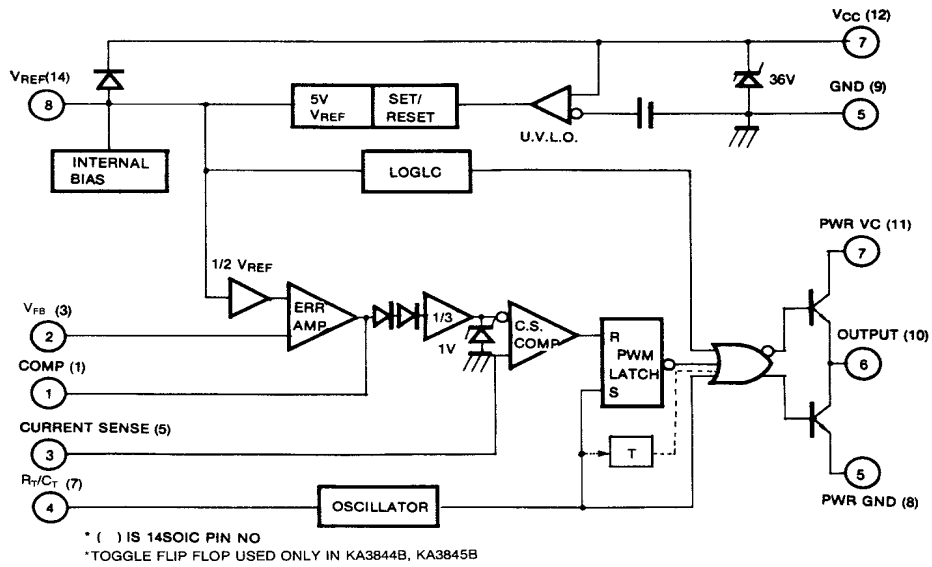

## Absolute Maximum Ratings

Parameter	Symbol	Value	Unit
Supply Voltage	V <sub>CC</sub>	30	V
Output Current	I <sub>O</sub>	±1	A
Analog Inputs (Pin 2,3)	V <sub>(ANA)</sub>	-0.3 to 6.3	V
Error Amp Output Sink Current	I <sub>SINK (E.A.)</sub>	10	mA
Power Dissipation (T <sub>A</sub> = 25°C)	PD	1	W

## Electrical Characteristics

( $V_{CC}=15V$ ,  $R_T=10K\Omega$ ,  $C_T=3.3nF$ ,  $T_A=0^\circ C$  to  $+70^\circ C$ , unless otherwise specified)

Parameter	Symbol	Conditions	Min.	Typ.	Max.	Unit
<b>REFERENCE SECTION</b>						
Reference Output Voltage	$V_{REF}$	$T_J = 25^\circ C$ , $I_{REF} = 1mA$	4.90	5.00	5.10	V
Line Regulation	$\Delta V_{REF}$	$12V \leq V_{CC} \leq 25V$	-	6	20	mV
Load Regulation	$\Delta V_{REF}$	$1mA \leq I_{REF} \leq 20mA$	-	6	25	mV
Short Circuit Output Current	$I_{SC}$	$T_A = 25^\circ C$	-	-100	-180	mA
<b>OSCILLATOR SECTION</b>						
Oscillation Frequency	f	$T_J = 25^\circ C$	47	52	57	KHz
Frequency Change with Voltage	$\Delta f/\Delta V_{CC}$	$12V \leq V_{CC} \leq 25V$	-	0.05	1	%
Oscillator Amplitude	$V_{OSC}$	-	-	1.6	-	V <sub>P-P</sub>
<b>ERROR AMPLIFIER SECTION</b>						
Input Bias Current	$I_{BIAS}$	-	-	-0.1	-2	$\mu A$
Input Voltage	$V_{I(E>A)}$	$V_1 = 2.5V$	2.42	2.50	2.58	V
Open Loop Voltage Gain	$G_{VO}$	$2V \leq V_O \leq 4V$	65	90	-	dB
Power Supply Rejection Ratio	PSRR	$12V \leq V_{CC} \leq 25V$	60	70	-	dB
Output Sink Current	$I_{SINK}$	$V_2 = 2.7V$ , $V_1 = 1.1V$	2	7	-	mA
Output Source Current	$I_{SOURCE}$	$V_2 = 2.3V$ , $V_1 = 5V$	-0.6	-1.0	-	mA
High Output Voltage	$V_{OH}$	$V_2 = 2.3V$ , $R_L = 15K\Omega$ to GND	5	6	-	V
Low Output Voltage	$V_{OL}$	$V_2 = 2.7V$ , $R_L = 15K\Omega$ to Pin 8	-	0.8	1.1	V
<b>CURRENT SENSE SECTION</b>						
Gain	$G_V$	(Note 1 & 2)	2.85	3	3.15	V/V
Maximum Input Signal	$V_{I(MAX)}$	$V_1 = 5V$ (Note 1)	0.9	1	1.1	V
Power Supply Rejection Ratio	PSRR	$12V \leq V_{CC} \leq 25V$ (Note 1)	-	70	-	dB
Input Bias Current	$I_{BIAS}$	-	-	-3	-10	$\mu A$
<b>OUTPUT SECTION</b>						
Low Output Voltage	$V_{OL}$	$I_{SINK} = 20mA$	-	0.08	0.4	V
		$I_{SINK} = 200mA$	-	1.4	2.2	V
High Output Voltage	$V_{OH}$	$I_{SOURCE} = 20mA$	13	13.5	-	V
		$I_{SOURCE} = 200mA$	12	13.0	-	V
Rise Time	$t_R$	$T_J = 25^\circ C$ , $C_L = 1nF$ (Note 3)	-	45	150	ns
Fall Time	$t_F$	$T_J = 25^\circ C$ , $C_L = 1nF$ (Note 3)	-	35	150	ns
<b>UNDER-VOLTAGE LOCKOUT SECTION</b>						
Start Threshold	$V_{TH(ST)}$	KA3842B/KA3844B	14.5	16.0	17.5	V
		KA3843B/KA3845B	7.8	8.4	9.0	V
Min. Operating Voltage (After Turn On)	$V_{OPR(MIN)}$	KA3842B/KA3844B	8.5	10.0	11.5	V
		KA3843B/KA3845B	7.0	7.6	8.2	V

## Electrical Characteristics (Continued)

(VCC=15V, RT=10KΩ, CT=3.3nF, TA= 0°C to +70°C unless otherwise specified)

Parameter	Symbol	Conditions	Min.	Typ.	Max.	Unit
<b>PWM SECTION</b>						
Max. Duty Cycle	D(max)	KA3842B/KA3843B	95	97	100	%
	D	KA3844B/KA3845B	47	48	50	%
Min. Duty Cycle	D(MIN)	-	-	-	0	%
<b>TOTAL STANDBY CURRENT</b>						
Start-Up Current	IST	-	-	0.45	1	mA
Operating Supply Current	ICC(OPR)	V3=V2=ON	-	14	17	mA
Zener Voltage	VZ	ICC = 25mA	30	38	-	V

Adjust VCC above the start threshold before setting at 15V

**Note:**

1. Parameter measured at trip point of latch
2. Gain defined as:

$$A = \frac{\Delta V_1}{\Delta V_3}, 0 \leq V_3 \leq 0.8V$$

3. These parameters, although guaranteed, are not 100 tested in production.

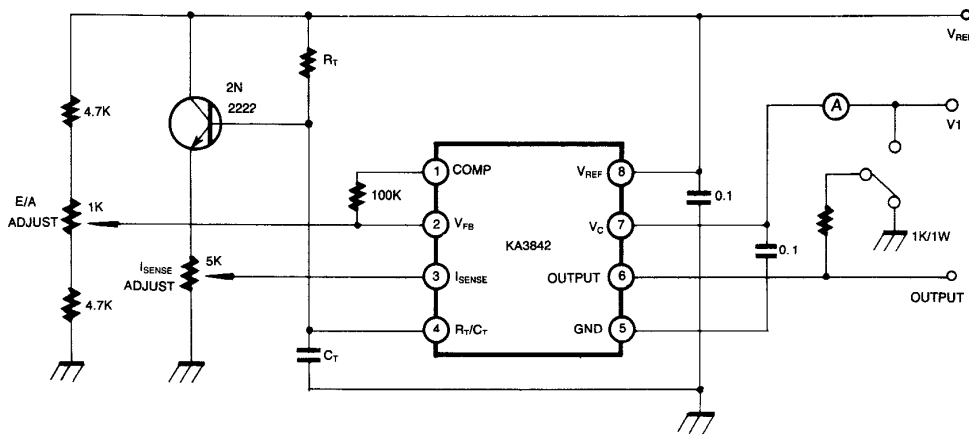

**Figure 1. Open Loop Test Circuit**

High peak currents associated with capacitive loads necessitate careful grounding techniques. Timing and bypass capacitors should be connected close to pin 5 in a single point ground. The transistor and 5KΩ potentiometer are used to sample the oscillator waveform and apply an adjustable ramp to pin 3.

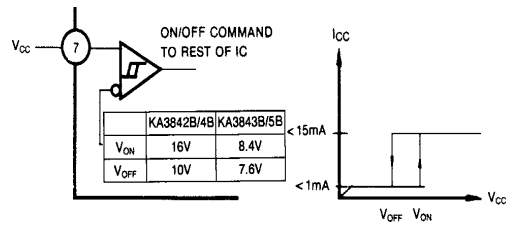

Figure 2. Under Voltage Lockout

During Under-Voltage Lock-Out, the output driver is biased to a high impedance state. Pin 6 should be shunted to ground with a bleeder resistor to prevent activating the power switch with output leakage current.

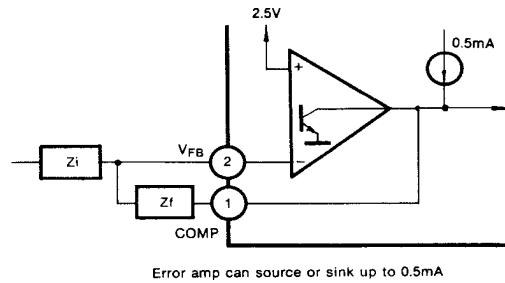

Figure 3. Error Amp Configuration

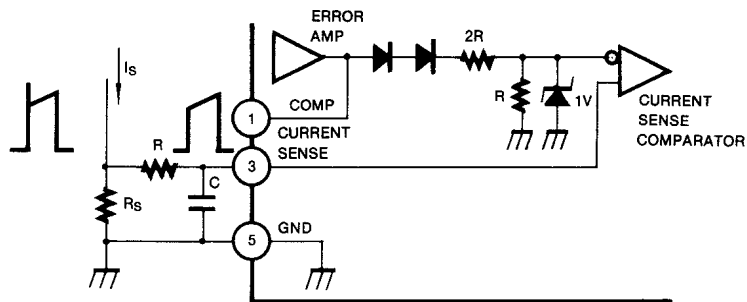

Figure 4. Current Sense Circuit

Peak current (I<sub>S</sub>) is determined by the formula:

$$I_S(\text{MAX}) = \frac{1.0V}{R_S}$$

A small RC filter may be required to suppress switch transients.

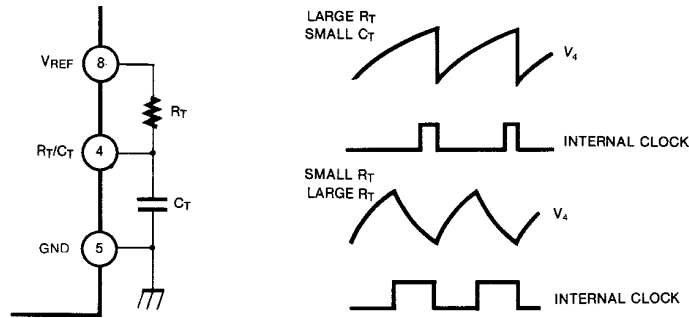

Figure 5. Oscillator Waveforms and Maximum Duty Cycle

Oscillator timing capacitor,  $C_T$ , is charged by  $V_{REF}$  through  $R_T$ , and discharged by an internal current source. During the discharge time, the internal clock signal blanks the output to the low state. Selection of  $R_T$  and  $C_T$  therefore determines both oscillator frequency and maximum duty cycle. Charge and discharge times are determined by the formulas:

$$t_c = 0.55 R_T C_T$$

$$t_D = R_T C_T I_n \left( \frac{0.0063 R_T - 2.7}{0.0063 R_T - 4} \right)$$

Frequency, then, is:  $f = (t_c + t_d)^{-1}$

$$\text{For } R_T > 5K\Omega, f = \frac{1.8}{R_T C_T}$$

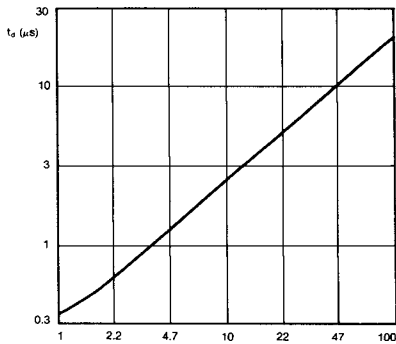

Figure 6. Oscillator Dead Time & Frequency  
(Deadtime vs  $C_T$   $R_T > 5k\Omega$ )

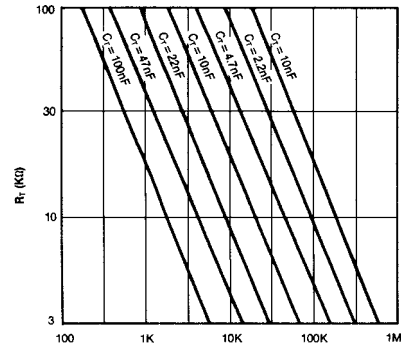

Figure 7. Timing Resistance vs Frequency

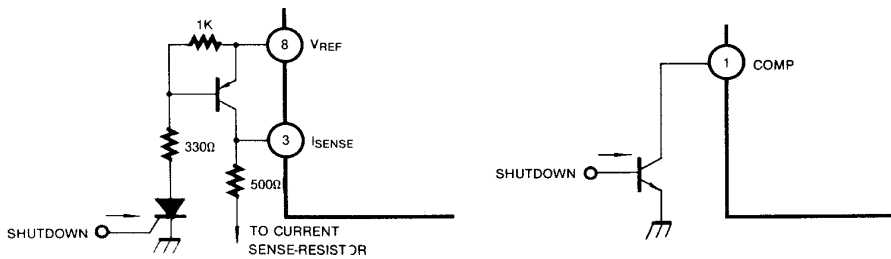

Figure 8. Shutdown Techniques

Shutdown of the KA3842B can be accomplished by two methods; either raise pin 3 above 1V or pull pin 1 below a voltage two diode drops above ground. Either method causes the output of the PWM comparator to be high (refer to block diagram). The PWM latch is reset dominant so that the output will remain low until the next clock cycle after the shutdown condition at pins 1 and/or 3 is removed. In one example, an externally latched shutdown may be accomplished by adding an SCR which will be reset by cycling Voc below the lower UVLO threshold. At this point the reference turns off, allowing the SCR to reset.

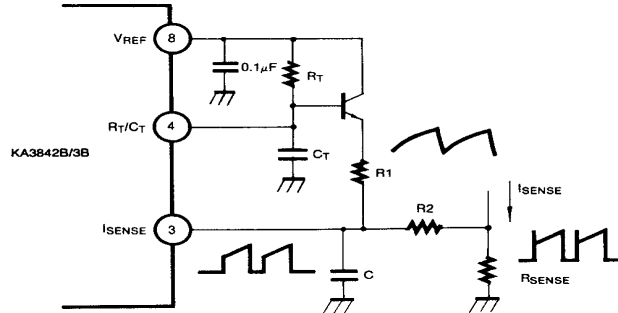

Figure 9. Slope Compensation

A fraction of the oscillator ramp can be resistively summed with the current sense signal to provide slope compensation for converters requiring duty cycles over 50%. Note that capacitor, C, forms a filter with R2 to suppress the leading edge switch spikes.

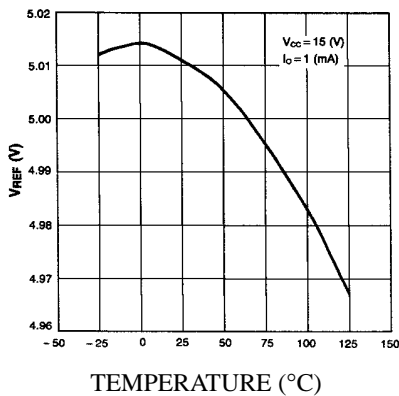

Figure 10. TEMPERATURE DRIFT (Vref)

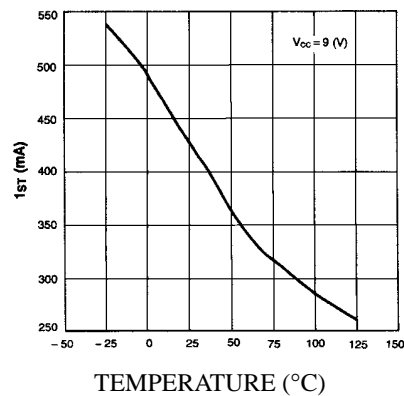

Figure 11. TEMPERATURE DRIFT (Ist)

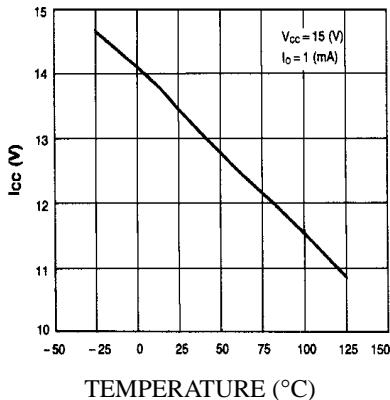
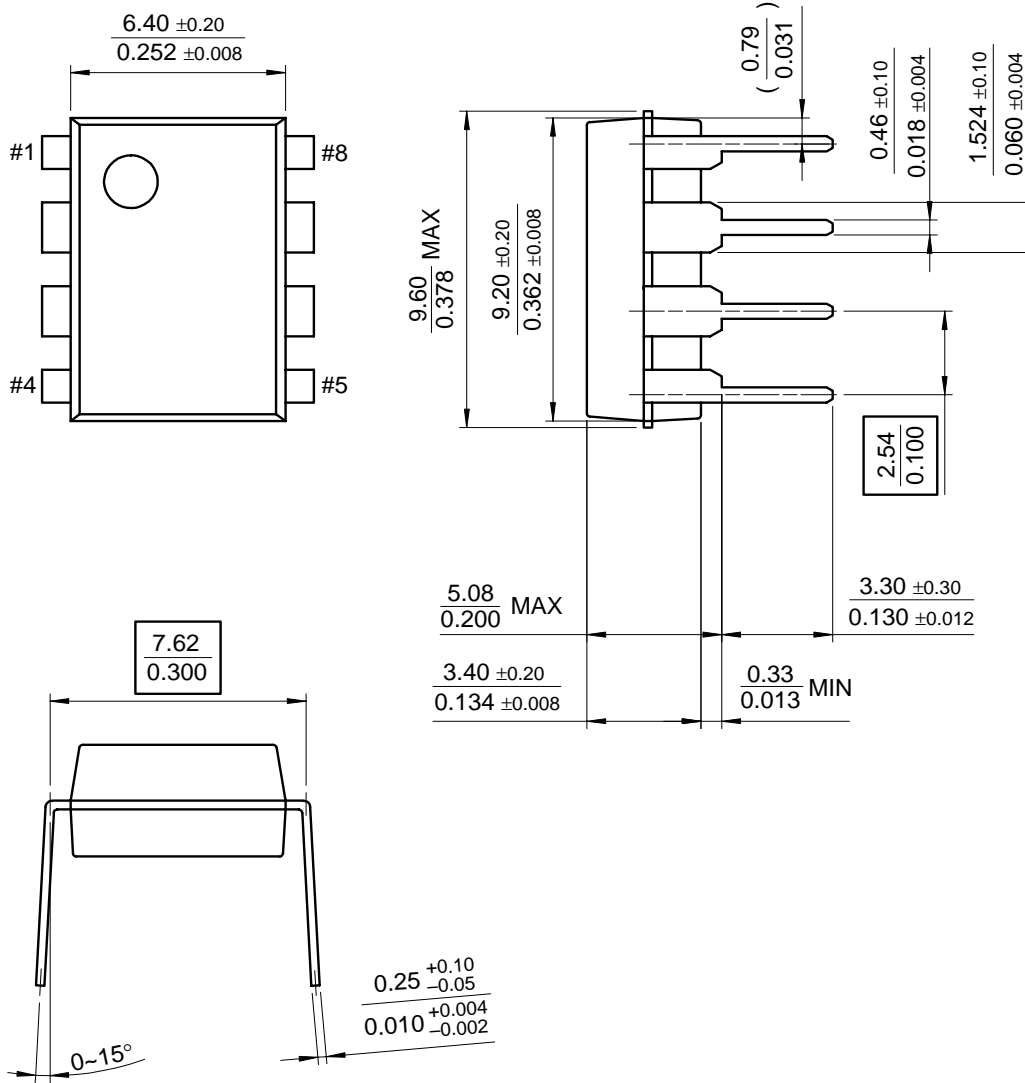

Figure 12. TEMPERATURE DRIFT (Icc)

# Mechanical Dimensions

## Package

### 8-DIP



**Mechanical Dimensions** (Continued)

**Package**

**14-SOP**

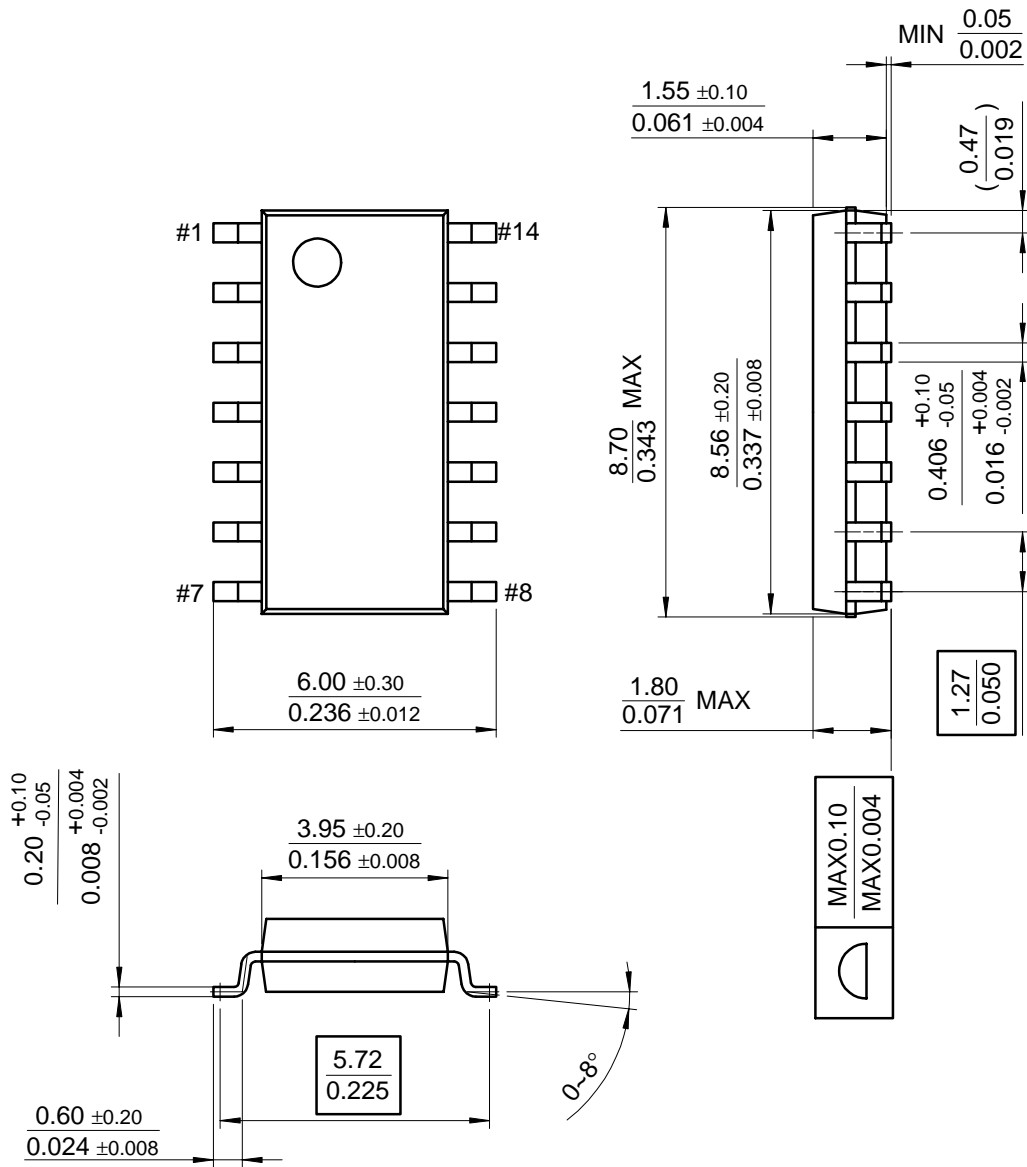

**Ordering Information**

Product Number	Package	Operating Temperature
KA3842B	8 DIP	0 ~ + 70°C
KA3843B		
KA3844B		
KA3845B		
KA3842BD		
KA3843BD	14 SOP	
KA3844BD		
KA3845BD		



**LIFE SUPPORT POLICY**

FAIRCHILD'S PRODUCTS ARE NOT AUTHORIZED FOR USE AS CRITICAL COMPONENTS IN LIFE SUPPORT DEVICES OR SYSTEMS WITHOUT THE EXPRESS WRITTEN APPROVAL OF THE PRESIDENT OF FAIRCHILD SEMICONDUCTOR INTERNATIONAL. As used herein:

1. Life support devices or systems are devices or systems which, (a) are intended for surgical implant into the body, or (b) support or sustain life, and (c) whose failure to perform when properly used in accordance with instructions for use provided in the labeling, can be reasonably expected to result in a significant injury of the user.
2. A critical component in any component of a life support device or system whose failure to perform can be reasonably expected to cause the failure of the life support device or system, or to affect its safety or effectiveness.

This datasheet has been downloaded from:

[www.DatasheetCatalog.com](http://www.DatasheetCatalog.com)

Datasheets for electronic components.



LittleDiode supplies new, hard to find or obsolete electronic components and semiconductors all over the world.

With over two million different components listed you are sure to find the part you need.

Feel free to visit us today at our online store:

[LittleDiode.com](http://LittleDiode.com)

Looking forward to providing you with the best possible service.