

**CURRENT MODE PWM CONTROLLER**

The KA3846 control IC provides all of the necessary features to implement fixed frequency, current mode control schemes while maintaining a minimum external parts count.

The superior performance of this technique can be measured in improved line regulation, enhanced load response characteristics, and a simpler, easier-to-design control loop. Topological advantages include inherent pulse-by-pulse current limiting capability, automatic symmetry correction for push-pull converters, and the ability to parallel "power module" while maintaining equal current sharing.

Protection circuitry includes built-in-under-voltage lockout and programmable current limit in addition to soft-start capability. A shutdown function is also available which can initiate either a complete shutdown with automatic restart or latch the supply off.

Other features include fully latched operation, double pulse suppression, deadtime adjust capability, and  $\pm 1\%$  trimmed bandgap reference. The KA3846 features low outputs in the OFF state.

**FEATURES**

- Automatic Feed Forward Compensation
- Programmable Pulse by Pulse Current Limiting
- Automatic Symmetry Correction in Push-Pull Configuration
- Enhanced Load Response Characteristics
- Parallel Operation Capability for Modulator Power Systems
- Differential Current Sense Amplifier with Common Mode Range
- Double Pulse Suppression
- 200mA Totem-Pole Outputs
- $\pm 1\%$  Bandgap Reference
- Under-Voltage Lockout
- Soft-Start Capability
- Shutdown Terminal
- 500KHz Operation

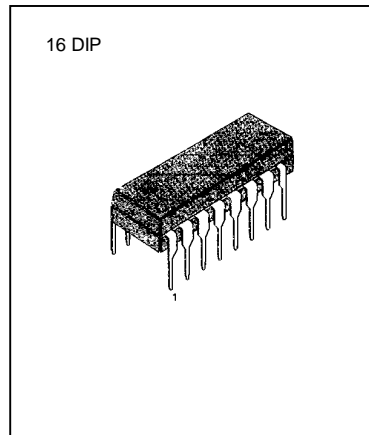

**ORDERING INFORMATION**

Device	Package	Operating Temperature
KA3846	16 DIP	0 ~ +70°C

**BLOCK DIAGRAM**

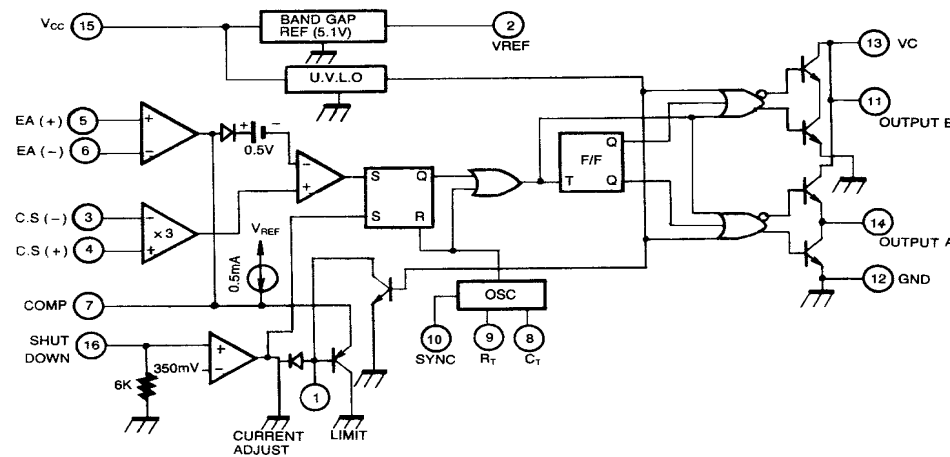

**ABSOLUTE MAXIMUM RATINGS**

Characteristic	Symbol	Value	Unit
Supply Voltage	$V_{CC}$	40	V
Collector Supply Voltage	$V_C$	40	V
Output Current, Sink or Source (Peak)	$I_O$	500	mA
Reference Output Current	$I_{REF}$	30	mA
Soft Start Sink Current	$I_{SINK(S.S)}$	50	mA
Sync Output Current	$I_{SYNC}$	5	mA
Error Amplifier Output Current	$I_{O(E.A)}$	5	mA
Oscillator Changing Current	$I_{CHG(OSC)}$	5	mA
Power Dissipation ( $T_A = 25^\circ\text{C}$ )	$P_D$	1000	mW
Operating Temperature	$T_{OPR}$	0 ~ +70	$^\circ\text{C}$
Storage Temperature	$T_{STG}$	-65 ~ +150	$^\circ\text{C}$
Lead Temperature (Soldering, 10sec)	$T_{LEAD}$	+300	$^\circ\text{C}$

**ELECTRICAL CHARACTERISTICS**

( $V_{CC}=15\text{V}$ ,  $T_A=0^\circ\text{C}$  to  $+70^\circ\text{C}$ , unless otherwise specified)

Characteristic	Symbol	Test Conditions	Min	Typ	Max	Unit
<b>REFERENCE SECTION</b>						
Reference Output Voltage	$V_{REF}$	$T_J = 25^\circ\text{C}$ , $I_{REF} = 1\text{mA}$	5.00	5.10	5.20	V
Line Regulation	$\Delta V_{REF}$	$V_{CC} = 8$ to $40\text{V}$		5	20	mV
Load Regulation	$\Delta V_{REF}$	$I_{REF} 1$ to $10\text{mA}$		3	15	mV
Temperature Stability(Note 6)	$ST_T$			0.4	1.0	mV/ $^\circ\text{C}$
Output Voltage Range(Note 6)	$V_{REF}$		4.95		5.25	V
Short Circuit Output Current	$I_{SC}$	$V_{REF} = 0\text{V}$	-10	-45		mA
Output Noise Voltage(Note 6)	$V_{NO}$	$f = 10\text{Hz}$ to $10\text{KHz}$ , $T_J = 25^\circ\text{C}$		100		$\mu\text{V}$
Long-Term Stability(Note 6)	$S_T$	$T_J = 125^\circ\text{C}$ , $1\text{KHz}$	2	5	8	mV

**ELECTRICAL CHARACTERISTICS**(V<sub>CC</sub>= 15V, T<sub>A</sub>=0°C to +70°C, unless otherwise specified)

Characteristic	Symbol	Test Conditions	Min	Typ	Max	Unit
<b>OSCILLATOR SECTION (Note 2)</b>						
Initial Accuracy	ACCUR	T <sub>J</sub> = 25°C	39	43	47	KHz
Frequency Change with Voltage	$\Delta f/\Delta V_{CC}$	V <sub>CC</sub> = 8 to 40V		- 1	2	%
Frequency Change with Temperature (Note 6)	$\Delta f/\Delta T$			- 1		%
Sync Output High Level	V <sub>OH(SYNC)</sub>		3.9	4.35		V
Sync Output Low Level	V <sub>OL(SYNC)</sub>			2.3	2.5	V
Sync Input High Level	V <sub>IH(SYNC)</sub>	V <sub>B</sub> = 0V	3.9			V
Sync Input Low Level	V <sub>IL(SYNC)</sub>	V <sub>B</sub> = 0V			2.5	V
Sync Input Current	I <sub>I(SYNC)</sub>	Sync Voltage = 3.9V, V <sub>B</sub> = 0V		1.3	1.5	mA
<b>ERROR AMPLIFIER SECTION</b>						
Input Offset Voltage	V <sub>IO</sub>			0.5	5	mV
Input Bias Current	I <sub>BIAS</sub>			-0.6	-1	μA
Input Offset Current	I <sub>IO</sub>			40	250	μA
Common-Mode Range	V <sub>CM</sub>	V <sub>CC</sub> = 8 to 40V	0		V <sub>CC</sub> /2	V
Open Loop Voltage Gain	G <sub>VO</sub>	V <sub>O</sub> = 1.2 to 3V, V <sub>CM</sub> = 2V	80	105		dB
Unity Gain Bandwidth(Note 6)	BW	T <sub>J</sub> = 25°C	0.7	1.0		MHz
Common Mode Rejection Ratio	CMRR	V <sub>CM</sub> = 0 to 38V, V <sub>CC</sub> = 40V	75	100		dB
Power Supply Rejection Ratio	PSRR	V <sub>CC</sub> = 8 to 40V	80	105		dB
Output Sink Current	I <sub>SINK</sub>	V <sub>IO</sub> = -15mV to 5V, V <sub>7</sub> = 2.5V	2	6		mA
Output Source Current	I <sub>SOURCE</sub>	R <sub>L</sub> = 15KΩ	-0.4	-0.5		mA
High Output Voltage	V <sub>OH</sub>	R <sub>L</sub> = 15KΩ	4.3	4.6		V
Low Output Voltage	V <sub>OL</sub>			0.7	1	V
<b>CURRENT SENSE AMPLIFIER SECTION</b>						
Amplifier Gain (Note 1, 3)	G <sub>V</sub>	V <sub>3</sub> = 0V, Pin 1 open	2.5	2.75	3.0	V
Maximum Differential Input Signal (V <sub>4</sub> - V <sub>3</sub> ) (Note 1)	V <sub>I(DIFF,MAX)</sub>	R <sub>L</sub> = 15KΩ, Pin 1 open	1.1	1.2		V
Input Offset Voltage (Note 1)	V <sub>IO</sub>	V <sub>1</sub> = 0.5V, Pin 1 open		5	25	mV
Common Mode Rejection Ratio	CMRR	V <sub>CM</sub> = 1 to 12V	60	83		dB
Power Supply Rejection Ratio	PSRR	V <sub>CC</sub> = 8 to 40V	60	84		dB
Input Bias Current (Note 1)	I <sub>BIAS</sub>	V <sub>1</sub> = 0.5V, Pin 7 open		-2.5	-10	μA
Input Offset Current (Note 1)	I <sub>IO</sub>	V <sub>1</sub> = 0.5V, Pin 7 open		0.08	1	μA
Delay to Outputs (Note 6)	t <sub>D</sub>	T <sub>J</sub> = 25°C		200	500	nS

**ELECTRICAL CHARACTERISTICS**(V<sub>CC</sub>=15V, T<sub>A</sub>=0°C to +70°C, unless otherwise specified)

Characteristic	Symbol	Test Conditions	Min	Typ	Max	Unit
<b>CURRENT LIMIT ADJUST SECTION</b>						
Current Limit Offset Voltage (Note 1)	V <sub>IO(CL)</sub>	V <sub>3</sub> = 0V V <sub>4</sub> = 0V, Pin 7 open	0.45	0.5	0.55	V
Input Bias Current	I <sub>BIAS</sub>	V <sub>5</sub> = V <sub>REF</sub> , V <sub>6</sub> = 0V		- 10	- 30	μ A
<b>SHUTDOWN TERMINAL SECTION</b>						
Threshold Voltage	V <sub>TH</sub>		250	350	400	mV
Input Voltage Range	V <sub>I</sub>		0		V <sub>CC</sub>	V
Minimum Latching Current (Note 4)	I <sub>(LATCH, MIN)</sub>		3.0	1.5		mA
Maximum Non-Latching Current (Note 5)	I <sub>(NONLATCH, MAX)</sub>			1.5	0.8	mA
<b>UNDER-VOLTAGE LOCKOUT SECTION</b>						
Start Threshold	V <sub>TH(ST)</sub>		7	7.7	8.4	V
Threshold Hysteresis	V <sub>HYS</sub>		0.45	0.75	1.05	V
<b>OUTPUT SECTION</b>						
Collector-Emitter Voltage	V <sub>CEO</sub>		40			V
Collector Leakage Current	I <sub>LEAK</sub>	V <sub>C</sub> = 40V			200	μ A
Low Output Voltage 1	V <sub>OL 1</sub>	I <sub>SINK</sub> = 20mA		0.1	0.4	V
Low Output Voltage 2	V <sub>OL 2</sub>	I <sub>SINK</sub> = 100mA		0.4	2.1	V
High Output Voltage 1	V <sub>OH 1</sub>	I <sub>SOURCE</sub> = 20mA	13	13.5		V
High Output Voltage 2	V <sub>OH 2</sub>	I <sub>SOURCE</sub> = 100mA	12	13.5		V
Rise Time (Note 6)	t <sub>R</sub>	C <sub>L</sub> = 1nF, T <sub>J</sub> = 25°C		50	300	μ S
Fall Time (Note 6)	t <sub>F</sub>	C <sub>L</sub> = 1nF, T <sub>J</sub> = 25°C		50	300	μ S
<b>TOTAL STANDBY CURRENT</b>						
Supply Current	I <sub>CC</sub>			17	21	mA

(Note)

1. Parameter measured at trip point at latch with V<sub>5</sub> = V<sub>REF</sub>, V<sub>6</sub> = 0V2. R<sub>T</sub> = 10KΩ, C<sub>T</sub> = 4.7nF3. Amplifier gain define as:  $G = \frac{\Delta V_7}{\Delta V_4}$ ; Δ V<sub>4</sub> = 0 to 1.0V

4. Current into Pin 1 guaranteed to latch circuit in shutdown state.

5. Current into Pin 1 guaranteed not to latch circuit in shutdown state.

6. These parameters, although guaranteed over the recommended operating conditions, are not 100% tested in production.

Fig. 1. KA3846 OSCILLATOR CIRCUIT

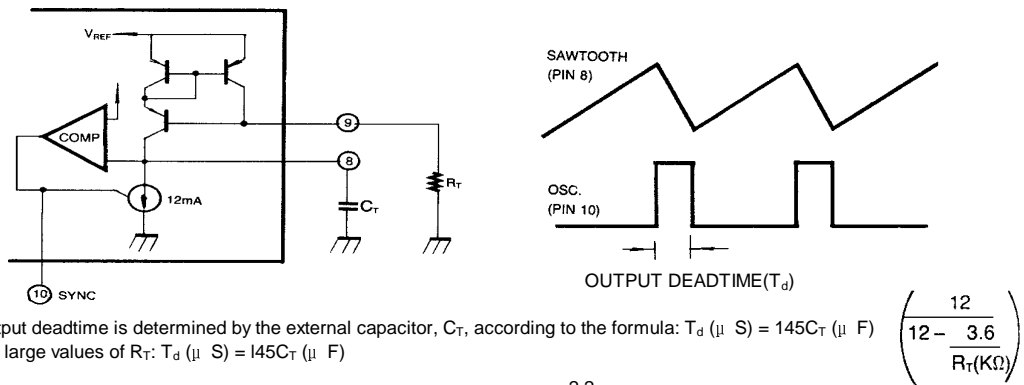

Fig. 2. ERROR AMPLIFIER OUTPUT CONFIGURATION

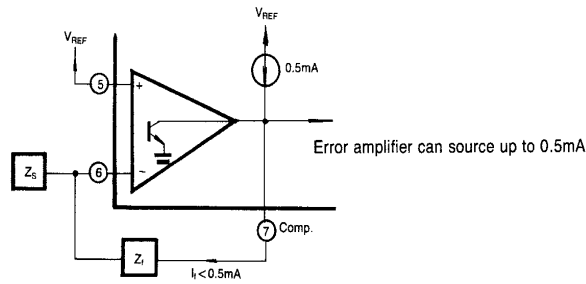

Fig. 3. PARALLEL OPERATION

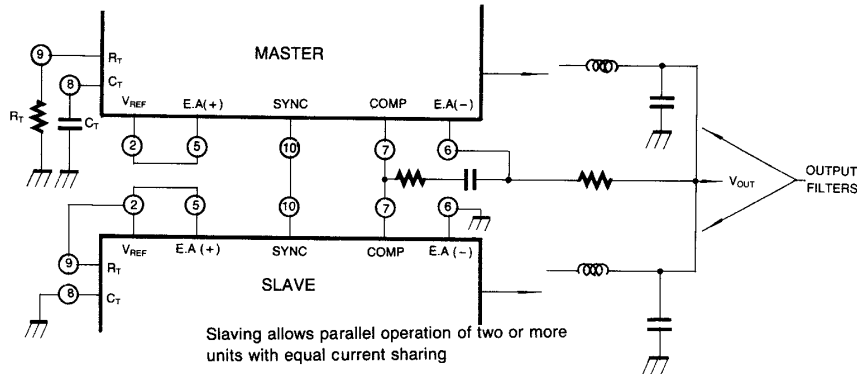

Fig. 4. PULSE BY

Fig. 4. PULSE CURRENT LIMITING

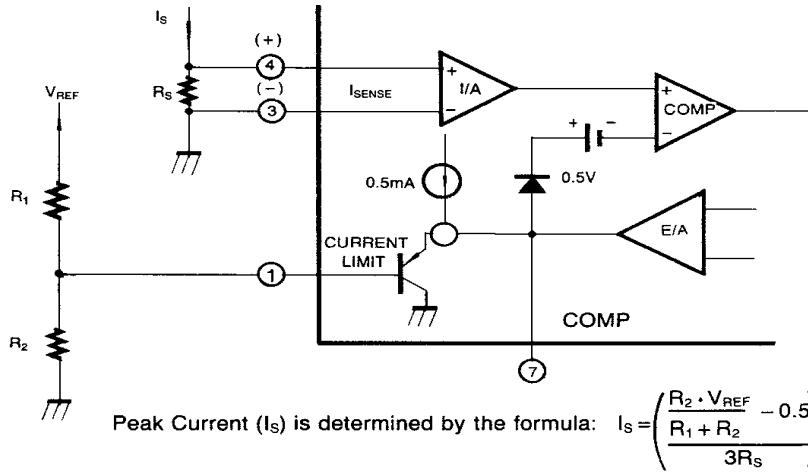
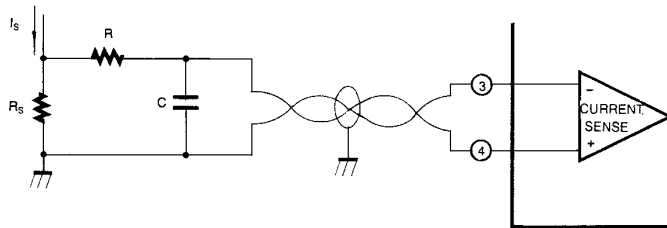

Fig. 5. CURRENT SENSE AMP CONNECTIONS



A small PC filter may be required in some applications to reduce switch transients  
Differential input allows remote, noise free sensing.

## TRADEMARKS

The following are registered and unregistered trademarks Fairchild Semiconductor owns or is authorized to use and is not intended to be an exhaustive list of all such trademarks.

ACEx™	ISOPLANAR™	UHC™
CoolFET™	MICROWIRE™	VCX™
CROSSVOLT™	POP™	
E <sup>2</sup> CMOS™	PowerTrench™	
FACT™	QST™	
FACT Quiet Series™	Quiet Series™	
FAST®	SuperSOT™-3	
FASTr™	SuperSOT™-6	
GTO™	SuperSOT™-8	
HiSeC™	TinyLogic™	

## DISCLAIMER

FAIRCHILD SEMICONDUCTOR RESERVES THE RIGHT TO MAKE CHANGES WITHOUT FURTHER NOTICE TO ANY PRODUCTS HEREIN TO IMPROVE RELIABILITY, FUNCTION OR DESIGN. FAIRCHILD DOES NOT ASSUME ANY LIABILITY ARISING OUT OF THE APPLICATION OR USE OF ANY PRODUCT OR CIRCUIT DESCRIBED HEREIN; NEITHER DOES IT CONVEY ANY LICENSE UNDER ITS PATENT RIGHTS, NOR THE RIGHTS OF OTHERS.

## LIFE SUPPORT POLICY

FAIRCHILD'S PRODUCTS ARE NOT AUTHORIZED FOR USE AS CRITICAL COMPONENTS IN LIFE SUPPORT DEVICES OR SYSTEMS WITHOUT THE EXPRESS WRITTEN APPROVAL OF FAIRCHILD SEMICONDUCTOR CORPORATION. As used herein:

1. Life support devices or systems are devices or systems which, (a) are intended for surgical implant into the body, or (b) support or sustain life, or (c) whose failure to perform when properly used in accordance with instructions for use provided in the labeling, can be reasonably expected to result in significant injury to the user.
2. A critical component is any component of a life support device or system whose failure to perform can be reasonably expected to cause the failure of the life support device or system, or to affect its safety or effectiveness.

## PRODUCT STATUS DEFINITIONS

### Definition of Terms

Datasheet Identification	Product Status	Definition
Advance Information	Formative or In Design	This datasheet contains the design specifications for product development. Specifications may change in any manner without notice.
Preliminary	First Production	This datasheet contains preliminary data, and supplementary data will be published at a later date. Fairchild Semiconductor reserves the right to make changes at any time without notice in order to improve design.
No Identification Needed	Full Production	This datasheet contains final specifications. Fairchild Semiconductor reserves the right to make changes at any time without notice in order to improve design.
Obsolete	Not In Production	This datasheet contains specifications on a product that has been discontinued by Fairchild semiconductor. The datasheet is printed for reference information only.