

FIXED MULTI-OUTPUT REGULATOR

The KA7630/1 is a multi-output positive voltage regulator designed to provide fixed precision output voltages of 5.1V, 8V (7630) / 9V (7631) at current up to 0.5A and 12V at current up to 1A with external PNP transistor. An internal reset circuit generates a reset pulse when the output 1 decrease below the regulated value.

Output 2 & 3 can be disabled by TTL input. Protection features include over voltage protection, short circuit protection and thermal shut down.

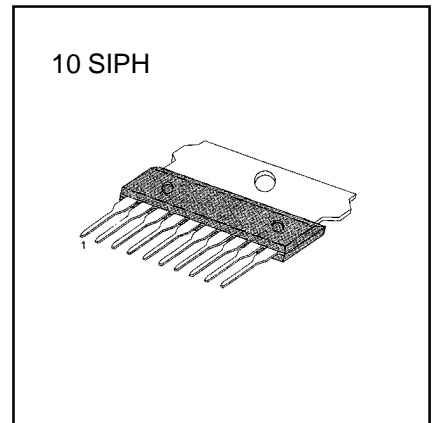

FEATURES

- Output Currents up to 0.5A (output 1 & 2)
- Output Current up to 1A with External Transistor (output 3)
- Fixed Precision Output 1 voltage $5.1V \pm 2\%$
- Fixed Precision Output 2 voltage $8V \pm 2\%$ (KA7630)
- Fixed Precision Output 2 voltage $9V \pm 2\%$ (KA7631)
- Control Signal Generator for Output 3 voltage ($12V \pm 2\%$)
- Reset Facility for Output Voltage 1
- Output 2,3 with Disable by TTL Input
- Current Limit Protection at Each Output
- Thermal Shut Down

ORDERING INFORMATION

Device	Package	Operating Temperature
KA7630/1	10 SIPH	0 ~ 125°C

BLOCK DIAGRAM

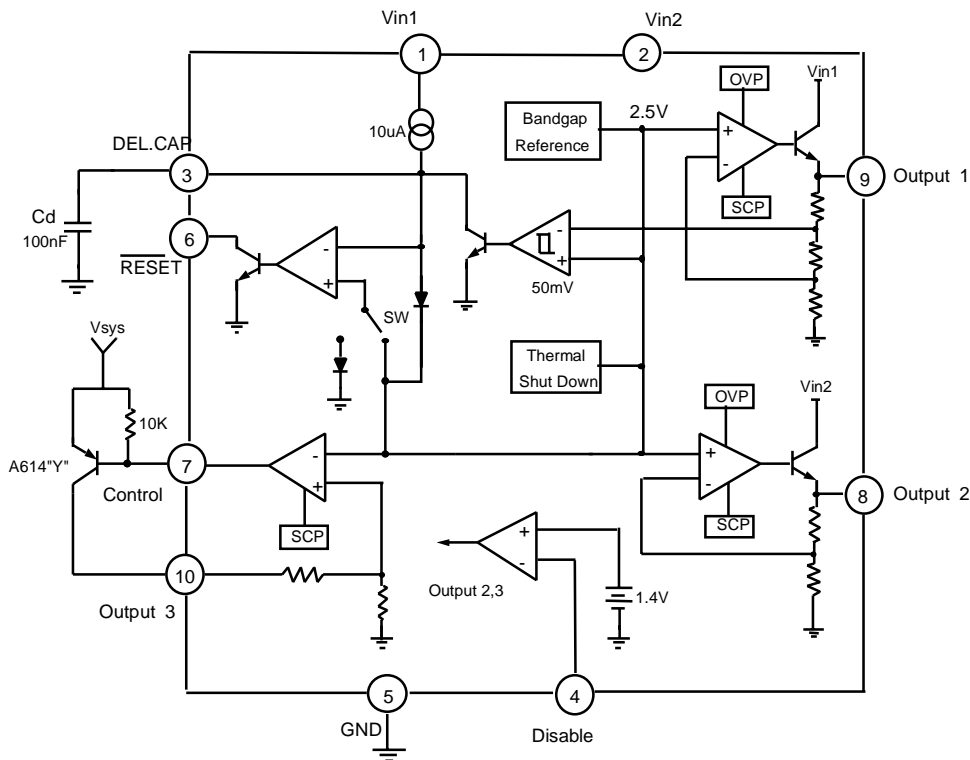

ABSOLUTE MAXIMUM RATINGS (Ta = 25 °C)

Characteristics	Symbol	Value	Unit	Remark
DC Input Voltage	Vin	20	V	-
Disable Input Voltage	Vc	20	V	-
Output Current	Io	0.5	A	-
Power Dissipation	Pd	1.5	W	No Heat sink
Junction Temperature	Tj	150	°C	-
Operating Temperature	Topr	0 ~ 125	°C	-

KA7630, ELECTRICAL CHARACTERISTICS

(Refer to test circuit Vin1=7.5V , Vin2=10.5V , Tj=25°C unless otherwise specified)

Characteristics	Symbol	Test Conditions	Min	Typ	Max	Unit
Output Voltage 1	Vo1	Io1=10mA 7.5V < Vin1 < 14V 5mA < Io1 < 500mA	5 4.9	5.1 5.1	5.2 5.3	V
Output Voltage 2	Vo2	Io2 = 10mA 10.5V < Vin2 < 18V 5mA < Io2 < 500mA	7.84 7.7	8 8	8.16 8.3	V
Dropout Output Voltage 1,2	Vd1,2	Io1,2=500mA			2.5	V
Line Regulation 1,2	ΔVo1,2	7.5V < Vin1 < 14V 10.5V < Vin2 < 18V Io1,2 = 200mA			50 80	mV
Load Regulation 1,2	ΔVo1,2	5mA < Io1 < 500mA 5mA < Io2 < 500mA			100 160	mV
Output Voltage 3	Vo3	Vsys =13V, Io3 =100mA	11.7	12	12.3	V
Line Regulation 3	ΔVo3	13V < Vin2 < 18V, Io3 =100mA			120	mV
Load Regulation 3	ΔVo3	5mA < Io3 < 1A			250	mV

KA7630, ELECTRICAL CHARACTERISTICS

(Refer to test circuit $V_{in1}=7.5V$, $V_{in2}=10.5V$, $T_j=25^\circ C$ unless otherwise specified)

Characteristics	Symbol	Test Conditions	Min	Typ	Max	Unit
Reset Pulse Delay	Trd	Cd = 100nF, Note1		25		ms
Saturation Voltage in Reset Condition	VrL	I6 = 5mA			0.4	V
Leakage Current at Pin 6	IrH	V6 = 10V			10	μA
Output Voltage Thermal Drift	STt	$0^\circ C \leq T_j \leq 125^\circ C$, Note 2		100		ppm/ $^\circ C$
Short Circuit Output Current	Isc1,2	$V_{in1}=7.5V$, $V_{in2} =10.5V$			1.6	A
Disable Voltage High	VdisH	Output 2 Active	2			V
Disable Voltage Low	VdisL	Output 2 Disabled			0.8	V
Disable Bias Current	Idis	$0V < V_{dis} < 7V$	-100		2	μA
Junction Temperature for TSD	Ttsd	Note 2		145		$^\circ C$
Quiescent Current	Iq	Io1=10mA, Output2 Disabled			2	mA
Reset Threshold Voltage	Vr	K=Vo1	K-0.4	K-0.25	K-0.1	V
Reset Threshold Hysteresis	Vrth	Note 1	20	50	100	mV

Note 1. To check the reset circuit ,the reset output is low to discharge the delay capacitor(=Cd). if it's less than $V_{o1}-0.25V$. And the reset output is high when the delay capacitor voltage linearly increased by the interal current source($10\mu A$) if it's more than $V_{o1}-0.2V$. The equations of delay time is same as below.

$$Trd = (Cd \times 2.5) / 10\mu A$$

2. These parameters, although guaranteed, are not 100% tested in production.

KA7631, ELECTRICAL CHARACTERISTICS

(Refer to test circuit $V_{in1}=7.5V$, $V_{in2}=11.5V$, $T_j=25^\circ C$ unless otherwise specified)

Characteristics	Symbol	Test Conditions	Min	Typ	Max	Unit
Output Voltage 1	V_{o1}	$I_{o1}=10mA$ $7.5V < V_{in1} < 14V$ $5mA < I_{o1} < 500mA$	5 4.9	5.1 5.1	5.2 5.3	V
Output Voltage 2	V_{o2}	$I_{o2} = 10mA$ $11.5V < V_{in2} < 18V$ $5mA < I_{o2} < 500mA$	8.82 8.65	9 9	9.18 9.35	V
Dropout Output Voltage 1,2	$V_{d1,2}$	$I_{o1,2}=500mA$			2.5	V
Line Regulation 1,2	$\Delta V_{o1,2}$	$7.5V < V_{in1} < 14V$ $11.5V < V_{in2} < 18V$ $I_{o1,2}=200mA$			50 80	mV
Load Regulation 1,2	$\Delta V_{o1,2}$	$5mA < I_{o1} < 500mA$ $5mA < I_{o2} < 500mA$			100 160	mV
Output Voltage 3	V_{o3}	$V_{sys} = 13V$, $I_{o3} = 100mA$	11.7	12	12.3	V
Line Regulation 3	ΔV_{o3}	$13V < V_{in2} < 18V$, $I_{o3} = 100mA$			120	mV
Load Regulation 3	ΔV_{o3}	$5mA < I_{o3} < 1A$			250	mV
Reset Pulse Delay	Trd	$C_d=100nF$, Note1		25		ms
Saturation Voltage in Reset Condition	V_{rL}	$I_6 = 5mA$			0.4	V
Leakage Current at Pin 6	I_{rH}	$V_6 = 10V$			10	μA
Output Voltage Thermal Drift	STt	$0^\circ C \leq T_j \leq 125^\circ C$, Note 2		100		ppm/ $^\circ C$
Short Circuit Output Current	$I_{sc1,2}$	$V_{in1}=7.5V$, $V_{in2} = 11.5V$			1.6	A

KA7631, ELECTRICAL CHARACTERISTICS(Refer to test circuit $V_{in1}=7.5V$, $V_{in2}=11.5V$, $T_j=25^{\circ}C$ unless otherwise specified)

Characteristic	Symbol	Test Conditions	Min	Typ	Max	Unit
Disable Voltage High	VdisH	Output 2 Active	2			V
Disable Voltage Low	VdisL	Output 2 Disabled			0.8	V
Disable Bias Current	Idis	$0V < V_{dis} < 7V$	-100		2	μA
Junction Temperature for TSD	Ttsd	Note 2		145		$^{\circ}C$
Quiescent Current	Iq	$I_{o1}=10mA$, Output2 Disabled			2	mA
Reset Threshold Voltage	Vr	$K=V_{o1}$	K-0.4	K-0.25	K-0.1	V
Reset Threshold Hysteresis	Vrth	Note 1	20	50	100	mV

Note 1. To check the reset circuit , the reset output is low to discharge the delay capacitor(=Cd) if it is less than $V_{o1}-0.25V$. And the reset output is high when the delay capacitor voltage linearly increased by the intercurrent source($10\mu A$) if it is more than $V_{o1}-0.2V$.

The equations of delay time is same as below.

$$Trd = (Cd \times 2.5) / 10\mu A$$

2. These parameters, although guaranteed, are not 100% tested in production.

TRADEMARKS

The following are registered and unregistered trademarks Fairchild Semiconductor owns or is authorized to use and is not intended to be an exhaustive list of all such trademarks.

ACEx™	ISOPLANAR™	UHC™
CoolFET™	MICROWIRE™	VCX™
CROSSVOLT™	POP™	
E ² CMOS™	PowerTrench™	
FACT™	QST™	
FACT Quiet Series™	Quiet Series™	
FAST®	SuperSOT™-3	
FASTr™	SuperSOT™-6	
GTO™	SuperSOT™-8	
HiSeC™	TinyLogic™	

DISCLAIMER

FAIRCHILD SEMICONDUCTOR RESERVES THE RIGHT TO MAKE CHANGES WITHOUT FURTHER NOTICE TO ANY PRODUCTS HEREIN TO IMPROVE RELIABILITY, FUNCTION OR DESIGN. FAIRCHILD DOES NOT ASSUME ANY LIABILITY ARISING OUT OF THE APPLICATION OR USE OF ANY PRODUCT OR CIRCUIT DESCRIBED HEREIN; NEITHER DOES IT CONVEY ANY LICENSE UNDER ITS PATENT RIGHTS, NOR THE RIGHTS OF OTHERS.

LIFE SUPPORT POLICY

FAIRCHILD'S PRODUCTS ARE NOT AUTHORIZED FOR USE AS CRITICAL COMPONENTS IN LIFE SUPPORT DEVICES OR SYSTEMS WITHOUT THE EXPRESS WRITTEN APPROVAL OF FAIRCHILD SEMICONDUCTOR CORPORATION. As used herein:

1. Life support devices or systems are devices or systems which, (a) are intended for surgical implant into the body, or (b) support or sustain life, or (c) whose failure to perform when properly used in accordance with instructions for use provided in the labeling, can be reasonably expected to result in significant injury to the user.
2. A critical component is any component of a life support device or system whose failure to perform can be reasonably expected to cause the failure of the life support device or system, or to affect its safety or effectiveness.

PRODUCT STATUS DEFINITIONS

Definition of Terms

Datasheet Identification	Product Status	Definition
Advance Information	Formative or In Design	This datasheet contains the design specifications for product development. Specifications may change in any manner without notice.
Preliminary	First Production	This datasheet contains preliminary data, and supplementary data will be published at a later date. Fairchild Semiconductor reserves the right to make changes at any time without notice in order to improve design.
No Identification Needed	Full Production	This datasheet contains final specifications. Fairchild Semiconductor reserves the right to make changes at any time without notice in order to improve design.
Obsolete	Not In Production	This datasheet contains specifications on a product that has been discontinued by Fairchild semiconductor. The datasheet is printed for reference information only.