

DUAL OPERATIONAL AMPLIFIER

The KF353 is a JFET input operational amplifier with an internally compensated input offset voltage. The JFET input device provides with bandwidth, low input bias currents and offset currents.

FEATURES

- Internally trimmed offset voltage: 10mV
- Low input bias current: 50pA
- Wide gain bandwidth: 4MHz
- High slew rate: 13V/ μ s
- High Input impedance: $10^{12}\Omega$

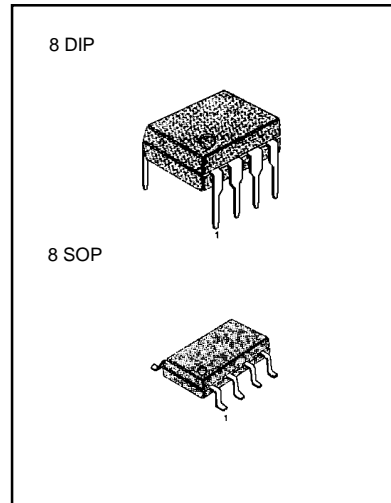

BLOCK DIAGRAM

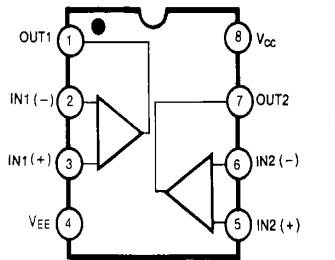

ORDERING INFORMATION

Device	Package	Operating Temperature
KF353	8 DIP	0 ~ + 70 °C
KF353D	8 SOP	
KF353S	9 SIP	

SCHEMATIC DIAGRAM (One Section Only)

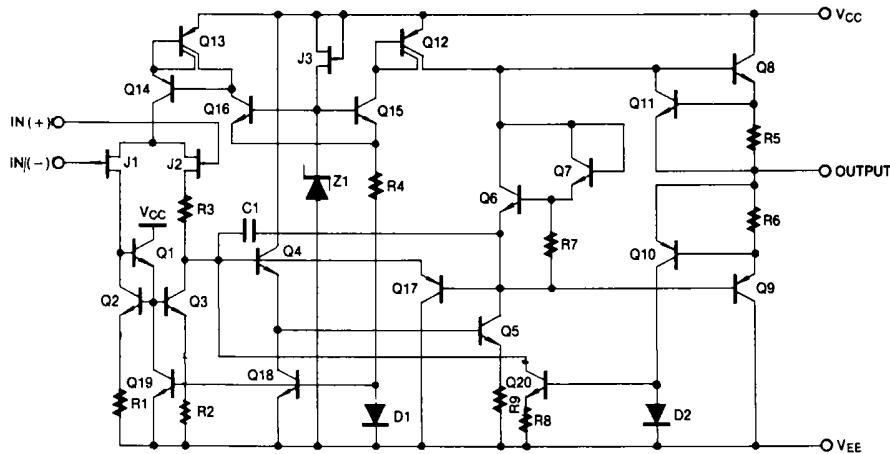

ABSOLUTE MAXIMUM RATINGS

Characteristics	Symbol	Value	Unit
Power Supply Voltage	V_{CC}	± 18	V
Differential Input Voltage	$V_{I(DIFF)}$	± 30	V
Input Voltage Range	V_I	± 15	V
Output Short Circuit Duration		Continuous	
Power Dissipation	P_D	500	mW
Operating Temperature Range	T_{OPR}	0 ~ +70	°C
Storage Temperature Range	T_{STG}	-65 ~ +150	°C

ELECTRICAL CHARACTERISTICS

(V_{CC} = +15V, V_{EE} = -15V, T_A = 25°C, unless otherwise specified)

Characteristic	Symbol	Test Conditions	Min	Typ	Max	Unit
Input Offset Voltage	V_{IO}	$R_S = 10K\Omega$ $0^\circ C \geq T_A \geq +70^\circ C$		5.0	10	mV
Input Offset Voltage Drift	$\Delta V_{IO}/\Delta T$	$R_S = 10K\Omega$ $0^\circ C \geq T_A \geq +70^\circ C$		10		$\mu V/^\circ C$
Input Offset Current	I_{IO}	$0^\circ C \geq T_A \geq +70^\circ C$		25	100	pA
Input Bias Current	I_{BIAS}	$0^\circ C \geq T_A \geq +70^\circ C$		50	200	pA
Input Resistance	R_I			10^{12}		Ω
Large Signal Voltage Gain	G_V	$V_{O(P-P)} = \pm 10V$ $R_L = 2K\Omega$ $0^\circ C \geq T_A \geq +70^\circ C$	25 15	100		V/mV
Output Voltage Swing	$V_{O(P,P)}$	$R_L = 10K\Omega$	± 12	± 13.5		V
Input Voltage Range	$V_{I(R)}$		± 11	$\pm 15/-12$		V
Common Mode Rejection Ratio	CMRR	$R_S \geq 10K\Omega$	70	100		dB
Power Supply Rejection Ratio	PSRR	$R_S \geq 10K\Omega$	70	100		dB
Power Supply Current	I_{CC}			3.6	6.5	mA
Slew Rate	SR	$G_V = 1$		13		V/ μ S
Gain-Bandwidth Product	GBM			4		MHz
Channel Separation	CS	$f = 1Hz \sim 20KHz$ (Input referenced)	120	120		dB
Equivalent Input Noise Voltage	V_{NI}	$R_S = 100\Omega$ $f = 1KHz$	16	16		$nV\sqrt{Hz}$
Equivalent Input Noise Current	I_{NI}	$f = 1KHz$	0.01	0.01		$pA\sqrt{Hz}$

TRADEMARKS

The following are registered and unregistered trademarks Fairchild Semiconductor owns or is authorized to use and is not intended to be an exhaustive list of all such trademarks.

ACEx™	ISOPLANAR™	UHC™
CoolFET™	MICROWIRE™	VCX™
CROSSVOLT™	POP™	
E ² CMOS™	PowerTrench™	
FACT™	QST™	
FACT Quiet Series™	Quiet Series™	
FAST®	SuperSOT™-3	
FASTr™	SuperSOT™-6	
GTO™	SuperSOT™-8	
HiSeC™	TinyLogic™	

DISCLAIMER

FAIRCHILD SEMICONDUCTOR RESERVES THE RIGHT TO MAKE CHANGES WITHOUT FURTHER NOTICE TO ANY PRODUCTS HEREIN TO IMPROVE RELIABILITY, FUNCTION OR DESIGN. FAIRCHILD DOES NOT ASSUME ANY LIABILITY ARISING OUT OF THE APPLICATION OR USE OF ANY PRODUCT OR CIRCUIT DESCRIBED HEREIN; NEITHER DOES IT CONVEY ANY LICENSE UNDER ITS PATENT RIGHTS, NOR THE RIGHTS OF OTHERS.

LIFE SUPPORT POLICY

FAIRCHILD'S PRODUCTS ARE NOT AUTHORIZED FOR USE AS CRITICAL COMPONENTS IN LIFE SUPPORT DEVICES OR SYSTEMS WITHOUT THE EXPRESS WRITTEN APPROVAL OF FAIRCHILD SEMICONDUCTOR CORPORATION. As used herein:

1. Life support devices or systems are devices or systems which, (a) are intended for surgical implant into the body, or (b) support or sustain life, or (c) whose failure to perform when properly used in accordance with instructions for use provided in the labeling, can be reasonably expected to result in significant injury to the user.
2. A critical component is any component of a life support device or system whose failure to perform can be reasonably expected to cause the failure of the life support device or system, or to affect its safety or effectiveness.

PRODUCT STATUS DEFINITIONS

Definition of Terms

Datasheet Identification	Product Status	Definition
Advance Information	Formative or In Design	This datasheet contains the design specifications for product development. Specifications may change in any manner without notice.
Preliminary	First Production	This datasheet contains preliminary data, and supplementary data will be published at a later date. Fairchild Semiconductor reserves the right to make changes at any time without notice in order to improve design.
No Identification Needed	Full Production	This datasheet contains final specifications. Fairchild Semiconductor reserves the right to make changes at any time without notice in order to improve design.
Obsolete	Not In Production	This datasheet contains specifications on a product that has been discontinued by Fairchild semiconductor. The datasheet is printed for reference information only.