

## 28 CHANNEL INK JET DRIVER

ADVANCE DATA

- 40V DMOS OUTPUT BREAKDOWN
- PRECISE OUTPUT ENERGY
- ESD OUTPUT PROTECTION WITH CLAMPING DIODES
- VERY LOW QUIESCENT CURRENT
- PLCC44 OR PQFP44 (10 x 10mm)

### DESCRIPTION

The L6451 is realized in Multipower BCD Technology which combines isolated DMOS power transistors with CMOS and Bipolar circuits on the same IC. By using mixed technology it has been possible to optimize the logic circuitry and the power stage to achieve the best possible performances.

Intended to be used in ink jet Printer Applications as 4 to 28 (2 x 14) lines selectable decoder/driver, the L6451 device driver has the advantages of low power CMOS inputs and logic, with 28 high current and high voltage DMOS outputs capable of sustaining a maximum of 40V.

On system power up the output drivers are locked out using the chip enable function; two enable inputs are available for the different driver banks.

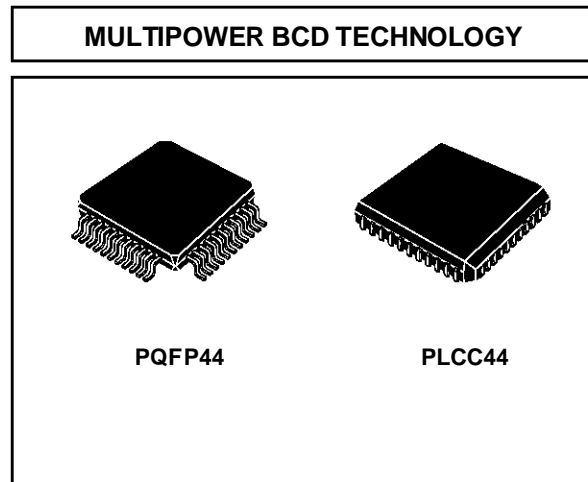

An internal power-on system is implemented in order to avoid wrong output commutation during the supply voltage transients.

Using a mask option during manufacturing allows a different decoding.

Control of the energy delivered to the print head is made by means of a special circuitry.

All driver outputs are capable of withstanding a contact discharge of  $\pm 8\text{kV}$  with the IC biased.

### BLOCK DIAGRAM (case of 4 bit)

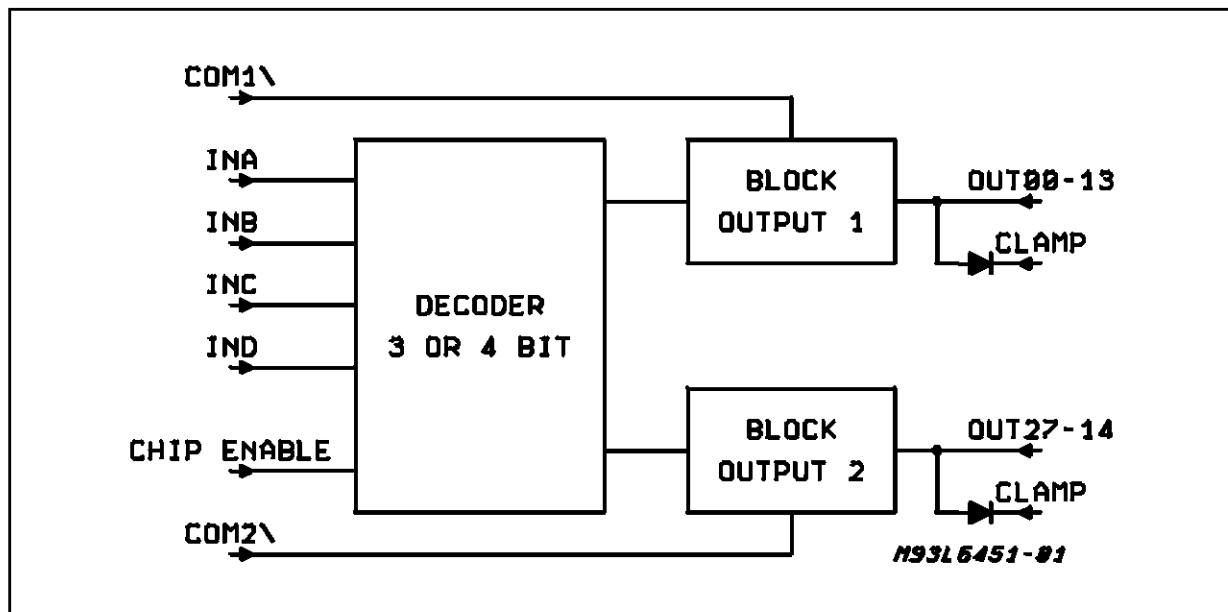

PLCC44 PIN CONNECTION (Top view)

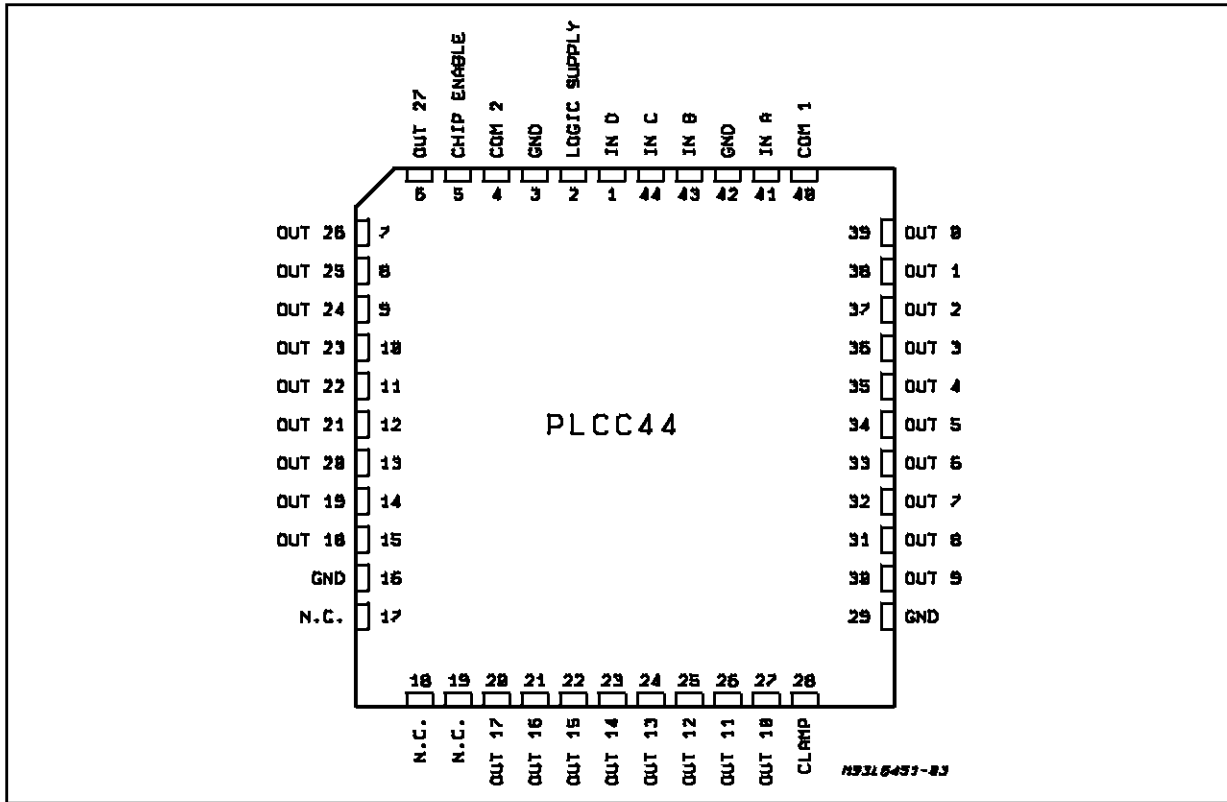

PQFP44 PIN CONNECTION (Top view)

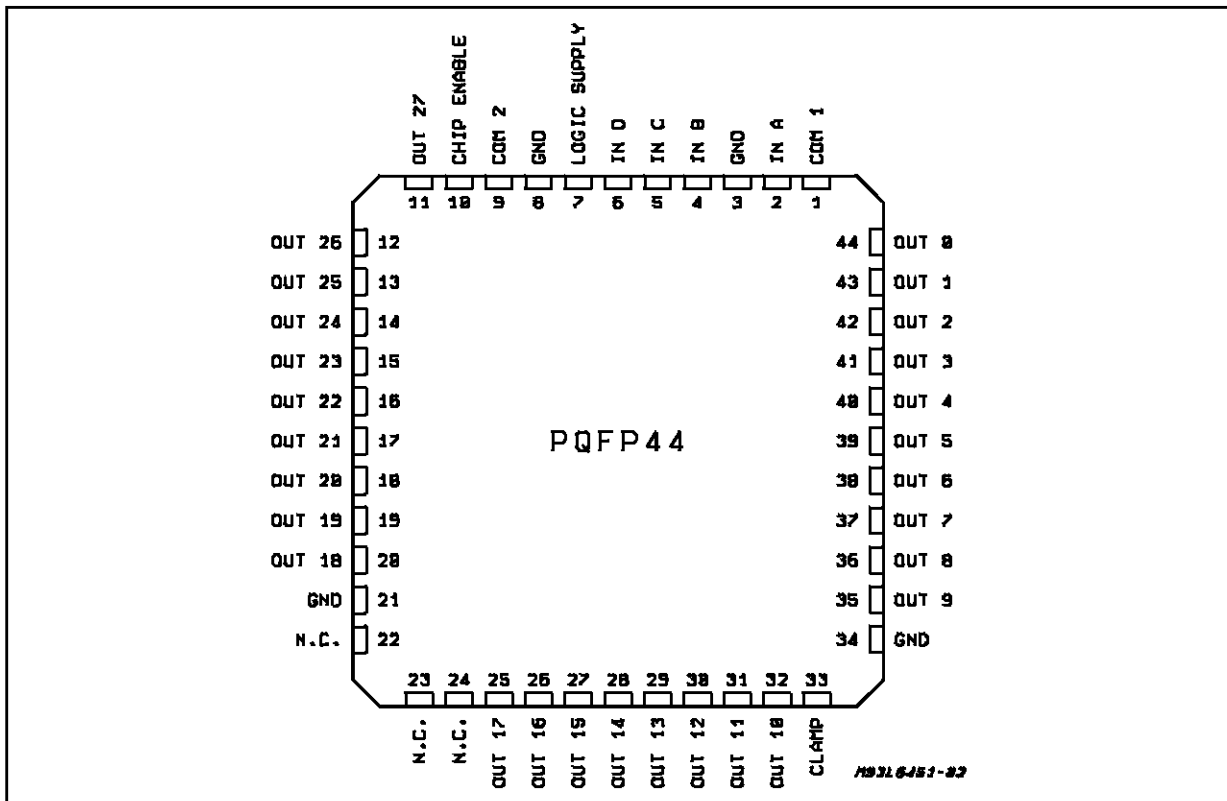

**ABSOLUTE MAXIMUM RATINGS**

Symbol	Parameter	Value	Unit
V <sub>OUT</sub>	Output Voltage	40	V
V <sub>CLAMP</sub>	Output Clamping Voltage	40	V
I <sub>OUT</sub>	Output Continuous Current	0.8	A
I <sub>PEAK</sub>	Output Peak Current (with duty cycle = 10% T <sub>ON</sub> = 4μs)	2	A
T <sub>J</sub>	Junction Temperature	150	°C
V <sub>DD</sub>	Logic Supply Voltage	7	V
V <sub>IN</sub>	Input Voltage Range	-0.3V to V <sub>S</sub> +0.3	V
T <sub>amb</sub>	Operating Temperature Range	0 to 70	°C
T <sub>stg</sub>	Storage Temperature Range	-55 to 150	°C

**PIN FUNCTIONS**

Name	Function
V <sub>DD</sub>	5V Logic Supply.
GND	Logic and Power Ground.
OUT0 to OUT27	DMOS Outputs.
CLAMP	This pin has to be connected to the power supply voltage of the head resistors. Each of the output DMOS have their drain connected with the anode of a protection diode, all the cathodes of the protection diodes are connected to the clamp pin. In order to have the device supplied, the CLAMP pin needs to be connected to the power..
INA, INB, INC, IND	Decoder inputs.
COM1, COM2	A low logic input on these pins enables the outputs selected by the decoder inputs.
CHIP ENABLE	A logic high enable the chip.

**THERMAL DATA**

Symbol	Parameter		PQFP44	PLCC44	Unit
R <sub>th j-amb</sub>	Thermal Resistance Junction-Ambient	Max.	55 (*)	65 (*)	°C/W

(\*) device mounted on PCB.

**D.C. ELECTRICAL CHARACTERISTICS** at  $T_{amb} = 25^{\circ}\text{C}$ ,  $V_{DD} = 5\text{V}$ ,  $V_{clamp} = 18\text{V}$  (unless otherwise specified).

Symbol	Parameter	Test Condition	Min.	Typ.	Max.	Unit
$V_{DD}$	Logic Supply Voltage		4.75	5	5.25	V
$V_{CLAMP}$	Clamping Voltage		9		38	V
$V_{IL}$	Low Level Input Voltage				1.2	V
$V_{IH}$	High Level Input Current		$V_{DD} - 1.2$			V
$I_{LL}$	Low Level Input Current	$V_{IN} = V_{IL}$			-200	$\mu\text{A}$
$I_{LH}$	High Level Input Current	$V_{IN} = V_{IH}$			10	$\mu\text{A}$
$I_{DD}$	Logic Supply Current	(Independent from the output conditions)			5	mA
$V_{OUT}$	Output Saturation Voltage	$T_j = 25^{\circ}\text{C}$ D.C. 0.4A $T_j = 25^{\circ}\text{C}$ D.C. 0.5A $T_j = 90^{\circ}\text{C}$ D.C. 0.4A $T_j = 90^{\circ}\text{C}$ D.C. 0.5A		0.9 1.1 1.4 1.7		V V V V
$\Delta V_{CE}$	Output saturation absolute voltage variation around the typ. values for extended temperature ranges	$T_j = 25^{\circ}\text{C}$ to $90^{\circ}\text{C}$ D.C.: 0.4A $T_j = 25^{\circ}\text{C}$ to $90^{\circ}\text{C}$ D.C.: 0.5A			$\pm 0.2$ $\pm 0.25$	V V
$R_{DS\ ON}$				2.2		$\Omega$

**A.C. ELECTRICAL CHARACTERISTICS** at  $T_{amb} = 25^{\circ}\text{C}$ ,  $V_{DD} = 5\text{V}$ .

Symbol	Signal Name	Parameter	Test Condition	Min.	Typ.	Max.	Unit
$T_S$	INA, INB, INC, IND Vs COMn	SET - UP Time		30			ns
$T_H$	INA, INB, INC, IND Vs COMn	HOLD Time		0			ns
$T_{on}$	COM1,2,3,4 Vs OUT 0 to N	TURN - ON Time	$I_{OUT} = 0.5\text{A}$ , $R_L = 39\Omega$ $T_j = 25$ to $90^{\circ}\text{C}$		150		ns
$T_{off}$	COM1,2,3,4 Vs OUT 0 to N	TURN - OFF Time	$I_{OUT} = 0.5\text{A}$ , $R_L = 39\Omega$ $T_j = 25$ to $90^{\circ}\text{C}$		150		ns
$t_r$		Rise Time			100		ns
$t_f$		Fall Time			100		ns
$T_{wout}$		Output Pulse Width	$T_{win} = 3.5\mu\text{s}$ $R_L = 40\Omega$ $I_{OUT} = 0.5\text{A}$	- 20	$T_{win}$	+ 80	ns
$\Delta P_D$		Maximum allowable variation of the output power transmitted by each driver to the resistive load	$R_L = 39\Omega$ $V_{CLAMP} = 18\text{V}$			$\pm 4$	%
$\Delta P_D$	Maximum allowable variation of the output power transmitted by each driver to the resistive load	$R_L = 40\Omega$ $V_{clamp} = 18\text{V}$			$\approx 4$	%	

Figure 1: Timing Waveforms

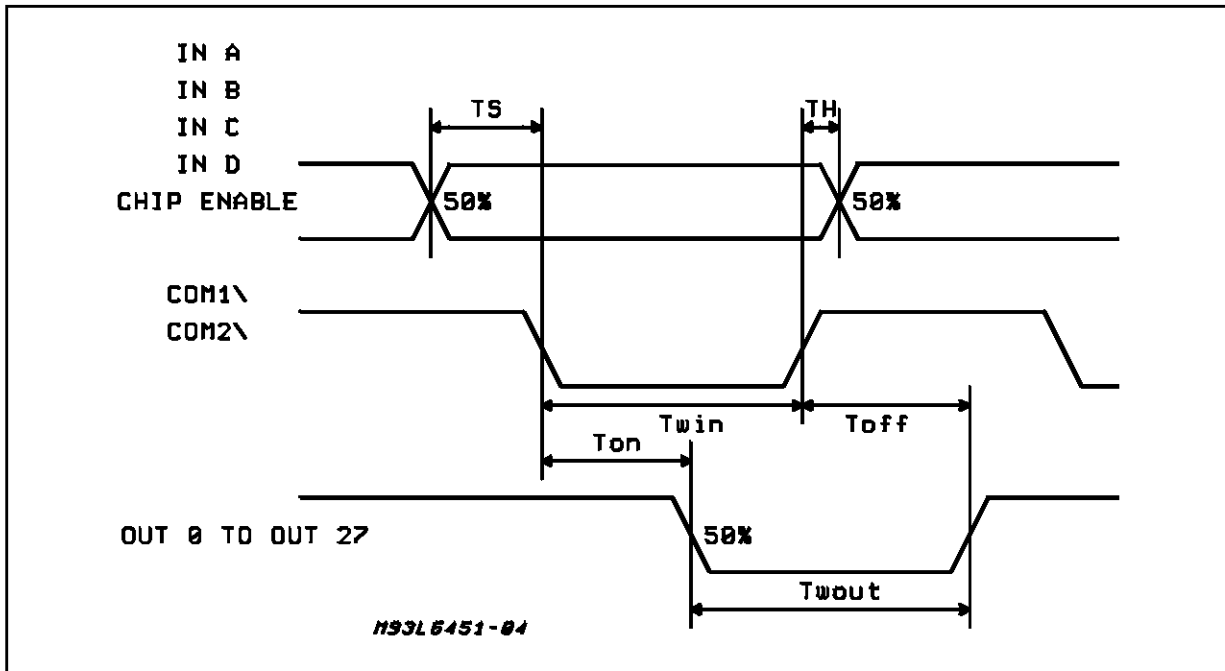

## OUTPUT SELECTION

Decoder Truth Table

IND	INC	INB	INA (LSB)	OUTPUTS
0	0	0	0	0.27
0	0	0	1	1.26
0	0	1	0	2.25
0	0	1	1	3.24
0	1	0	0	4.23
0	1	0	1	5.22
0	1	1	0	6.21
0	1	1	1	7.20
1	0	0	0	8.19
1	0	0	1	9.18
1	0	1	0	10.17
1	0	1	1	11.16
1	1	0	0	12.15
1	1	0	1	13.14
1	1	1	0	ALL OFF
1	1	1	1	ALL OFF

Figure 2: Application Circuit

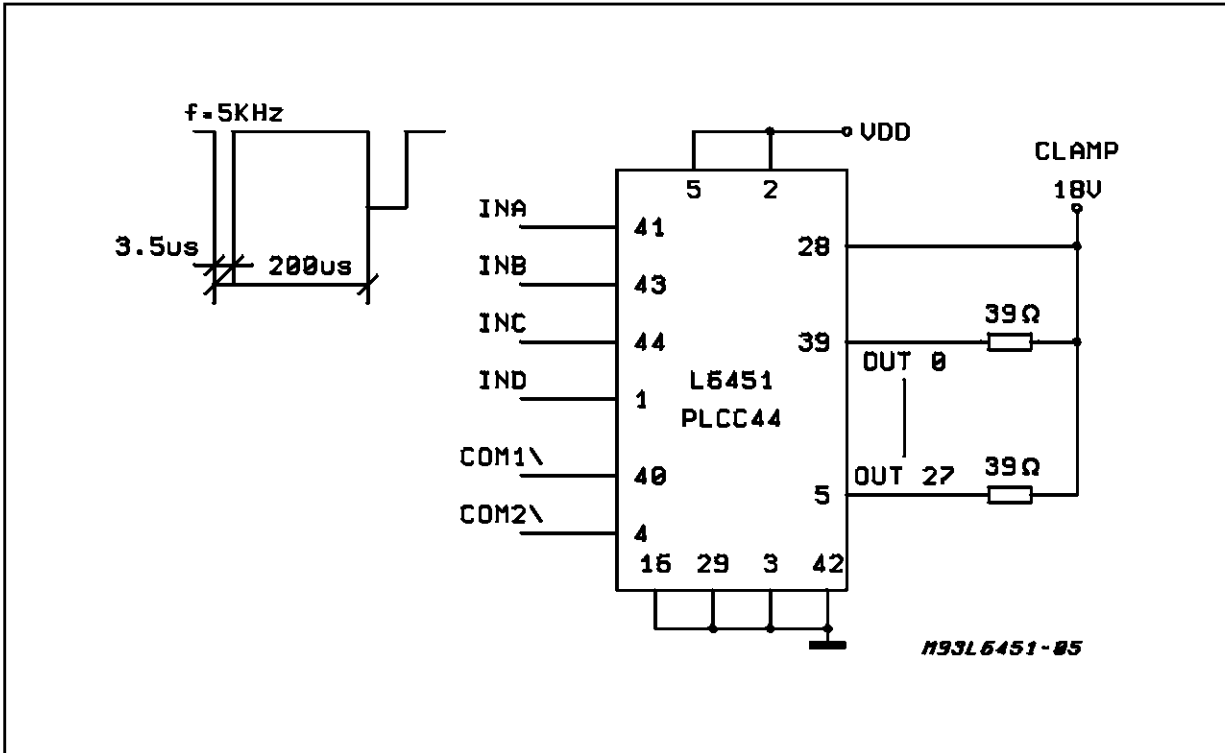

Information furnished is believed to be accurate and reliable. However, SGS-THOMSON Microelectronics assumes no responsibility for the consequences of use of such information nor for any infringement of patents or other rights of third parties which may result from its use. No license is granted by implication or otherwise under any patent or patent rights of SGS-THOMSON Microelectronics. Specifications mentioned in this publication are subject to change without notice. This publication supersedes and replaces all information previously supplied. SGS-THOMSON Microelectronics products are not authorized for use as critical components in life support devices or systems without express written approval of SGS-THOMSON Microelectronics.

© 1993 SGS-THOMSON Microelectronics - Printed in Italy - All Rights Reserved

**SGS-THOMSON Microelectronics GROUP OF COMPANIES**

Australia - Brazil - France - Germany - Hong Kong - Italy - Japan - Korea - Malaysia - Malta - Morocco - The Netherlands - Singapore - Spain - Sweden - Switzerland - Taiwan - United Kingdom - U.S.A.

## PQFP44 (14 x 14) PACKAGE MECHANICAL DATA

DIM.	mm			inch		
	MIN.	TYP.	MAX.	MIN.	TYP.	MAX.
A			3.40			0.134
A1	0.25			0.0098		
A2	2.55	2.80	3.05	0.100	0.110	0.120
B	0.35		0.50	0.0138		0.0197
C	0.13		0.23	0.005		0.009
D	16.95	17.20	17.45	0.667	0.677	0.687
D1	13.90	14.00	14.10	0.547	0.551	0.555
D3		10.00			0.394	
e		1.00			0.039	
E	16.95	17.20	17.45	0.667	0.677	0.687
E1	13.90	14.00	14.10	0.547	0.551	0.555
E3		10.00			0.394	
L	0.65	0.80	0.95	0.025	0.0315	0.0374
L1		1.60			0.063	
K	0°(min.), 7°(max.)					

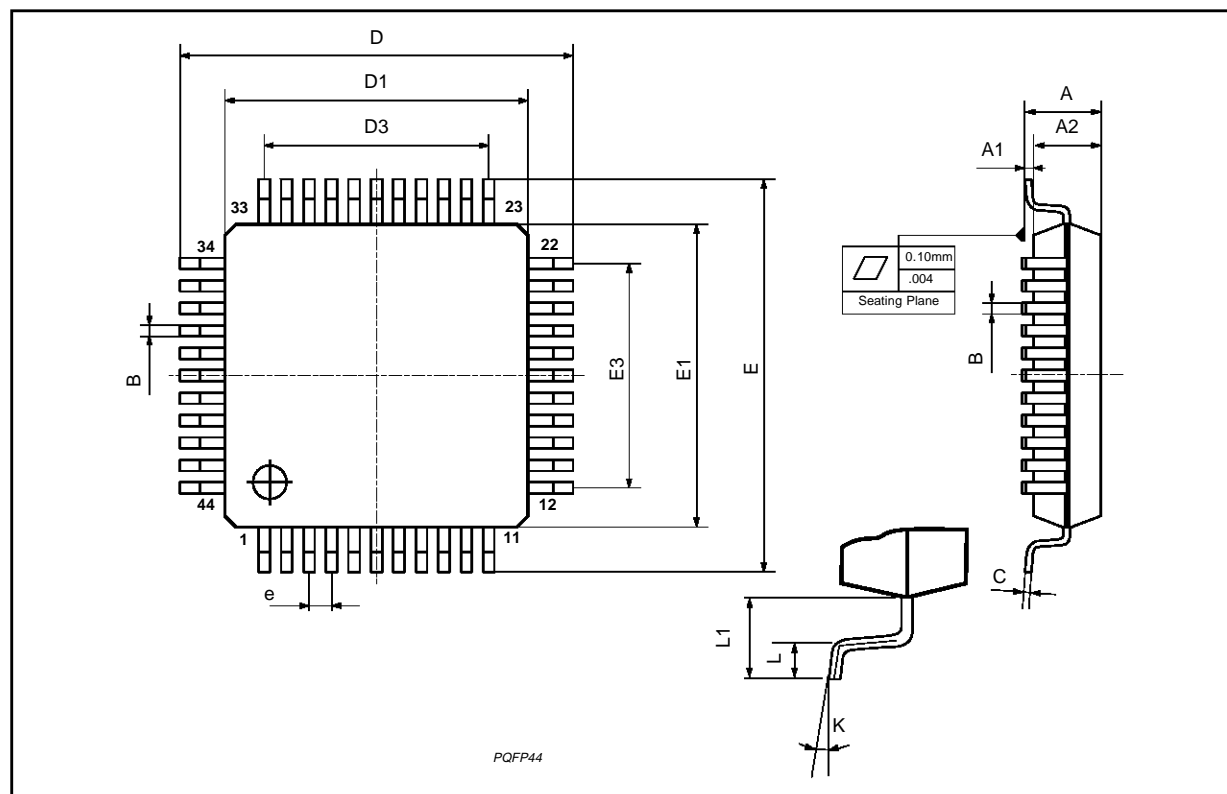

## PLCC44 PACKAGE MECHANICAL DATA

DIM.	mm			inch		
	MIN.	TYP.	MAX.	MIN.	TYP.	MAX.
A	17.4		17.65	0.685		0.695
B	16.51		16.65	0.650		0.656
C	3.65		3.7	0.144		0.146
D	4.2		4.57	0.165		0.180
d1	2.59		2.74	0.102		0.108
d2		0.68			0.027	
E	14.99		16	0.590		0.630
e		1.27			0.050	
e3		12.7			0.500	
F		0.46			0.018	
F1		0.71			0.028	
G			0.101			0.004
M		1.16			0.046	
M1		1.14			0.045	

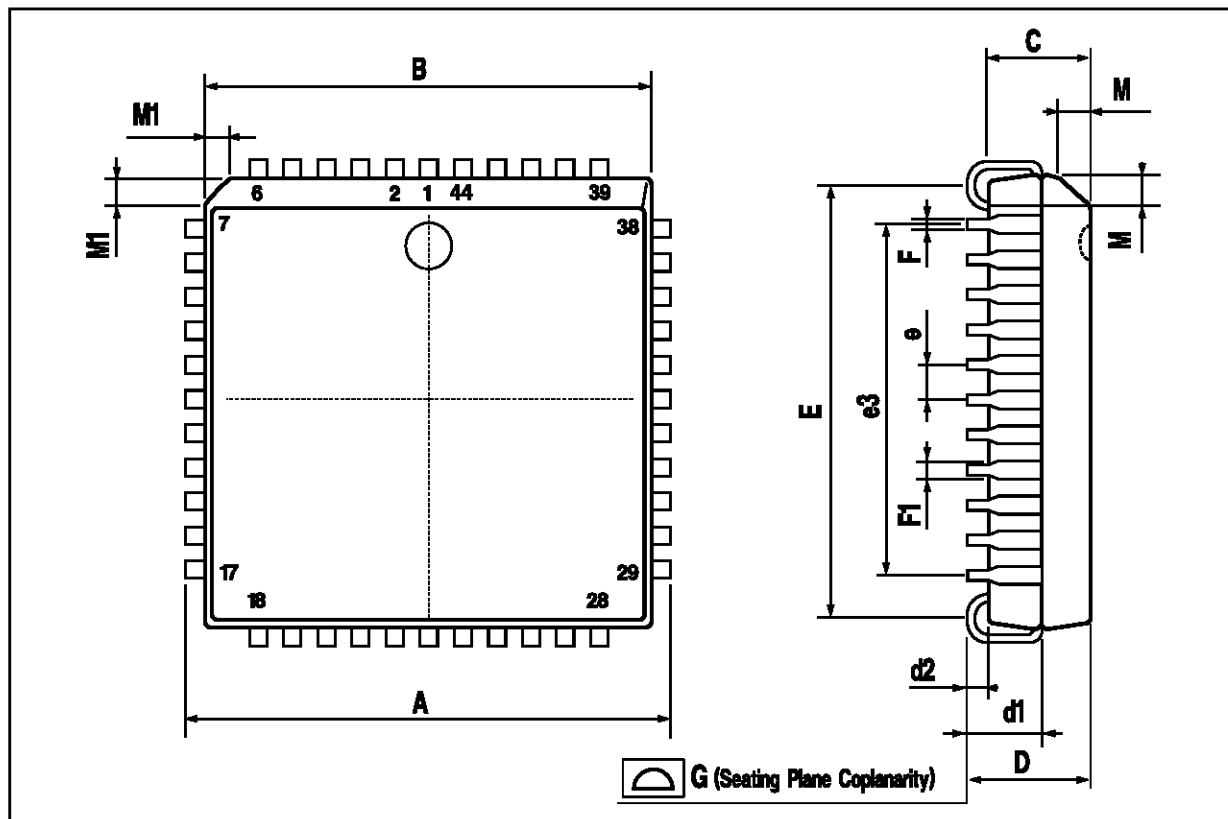

Information furnished is believed to be accurate and reliable. However, SGS-THOMSON Microelectronics assumes no responsibility for the consequences of use of such information nor for any infringement of patents or other rights of third parties which may result from its use. No license is granted by implication or otherwise under any patent or patent rights of SGS-THOMSON Microelectronics. Specifications mentioned in this publication are subject to change without notice. This publication supersedes and replaces all information previously supplied. SGS-THOMSON Microelectronics products are not authorized for use as critical components in life support devices or systems without express written approval of SGS-THOMSON Microelectronics.

© 1995 SGS-THOMSON Microelectronics - All Rights Reserved

SGS-THOMSON Microelectronics GROUP OF COMPANIES

Australia - Brazil - France - Germany - Hong Kong - Italy - Japan - Korea - Malaysia - Malta - Morocco - The Netherlands - Singapore - Spain - Sweden - Switzerland - Taiwan - Thailand - United Kingdom - U.S.A.