

**SOLENOID CONTROLLER**

PRELIMINARY DATA

- SWITCH MODE CURRENT REGULATION
- TTL COMPATIBLE LOGIC INPUTS
- DRIVES ONE OR TWO EXTERNAL POWER TRANSISTORS
- VERY PRECISE ON-CHIP REFERENCE
- ANALOG CURRENT CONTROL INPUT
- ADJUSTABLE CURRENT RISE AND FALL TIME CONTROL INDEPENDENT OF SOLENOID SUPPLY VOLTAGE
- UNDERVOLTAGE LOCKOUT

**DESCRIPTION**

Designed for use with one external power transistor, the L6504 drives the hammer solenoid in daisy-wheel printers and typewrites. The device is controlled by three logic inputs and features switchmode regulation of the load current. A key feature of the device is that the rise and fall time of the load current can be set by external components. Additionally an analog input allows the load current to be set by an external DC voltage. An undervoltage lockout circuit guarantees the output off state for switch on phase.

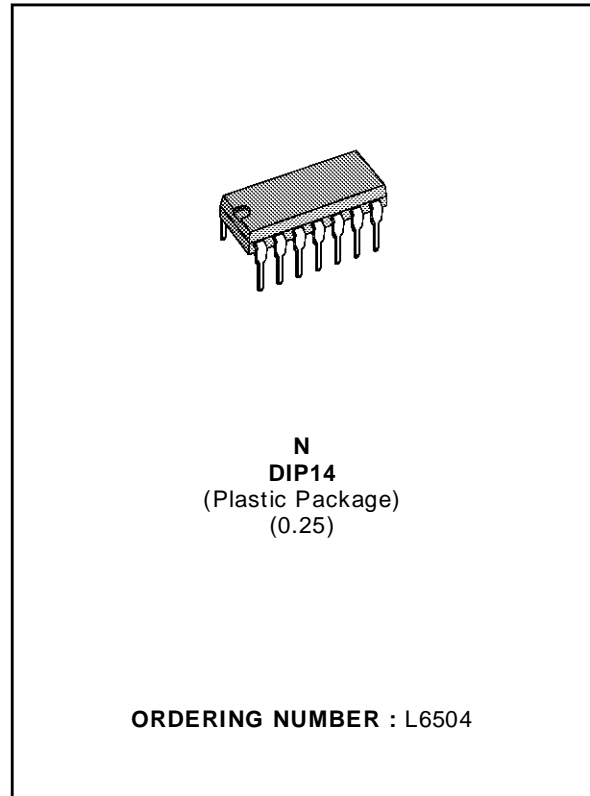

**PIN CONNECTION (top view)**

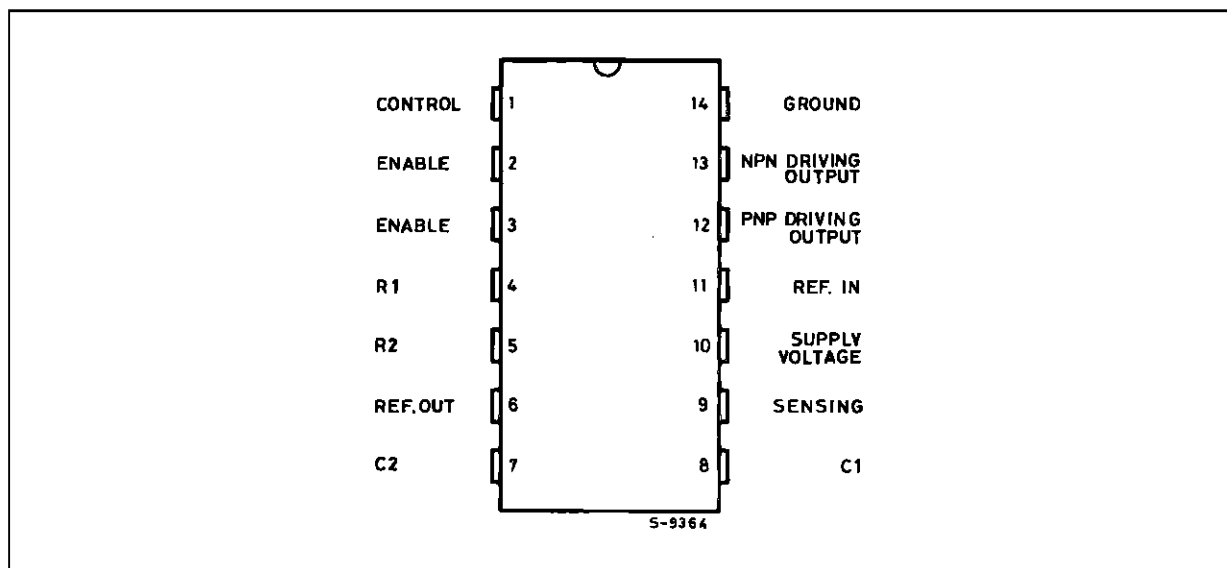

**PIN FUNCTION**

N°	Name	Function
1	CONTROL	TTL Compatible Control Input. A low level activates the output, driving the load. Internal Pull-up Resistor.
2	ENABLE	TTL Compatible Enable Input. A low level disables the output stage.
3	ENABLE	TTL Compatible Enable Input. A high level disables the output stage.
4	R1	The value of this resistor (*) sets slope of trailing edge of load current.
5	R2	The value of this resistor (*) sets slope of leading edge of load current.
6	REFERENCE OUT	Output for Internal Reference Voltage.
7	C2	The value of this capacitor set the duration of power transistor switch off time.
8	C1	The value of this capacitor sets slope of leading and trailing edge of load current.
9	SENSING	Connection for Load Current Sense Resistor. Value sets the maximum load current : $I = V_{ref}/R_s$ .
10	SUPPLY VOLTAGE	Supply Voltage Input.
11	REFERENCE IN	Input for External Reference Voltage to Control Load Current by DC-level.
12	PNP DRIVING OUTPUT	Output to Control External PNP-transistor for Fast Current Discharge.
13	NPN DRIVING OUTPUT	Output for Basecharge and Discharge of External Power Transistor.
14	GROUND	Ground

(\*) Value between 10 kΩ and 200 kΩ (or open).

**BLOCK DIAGRAM**

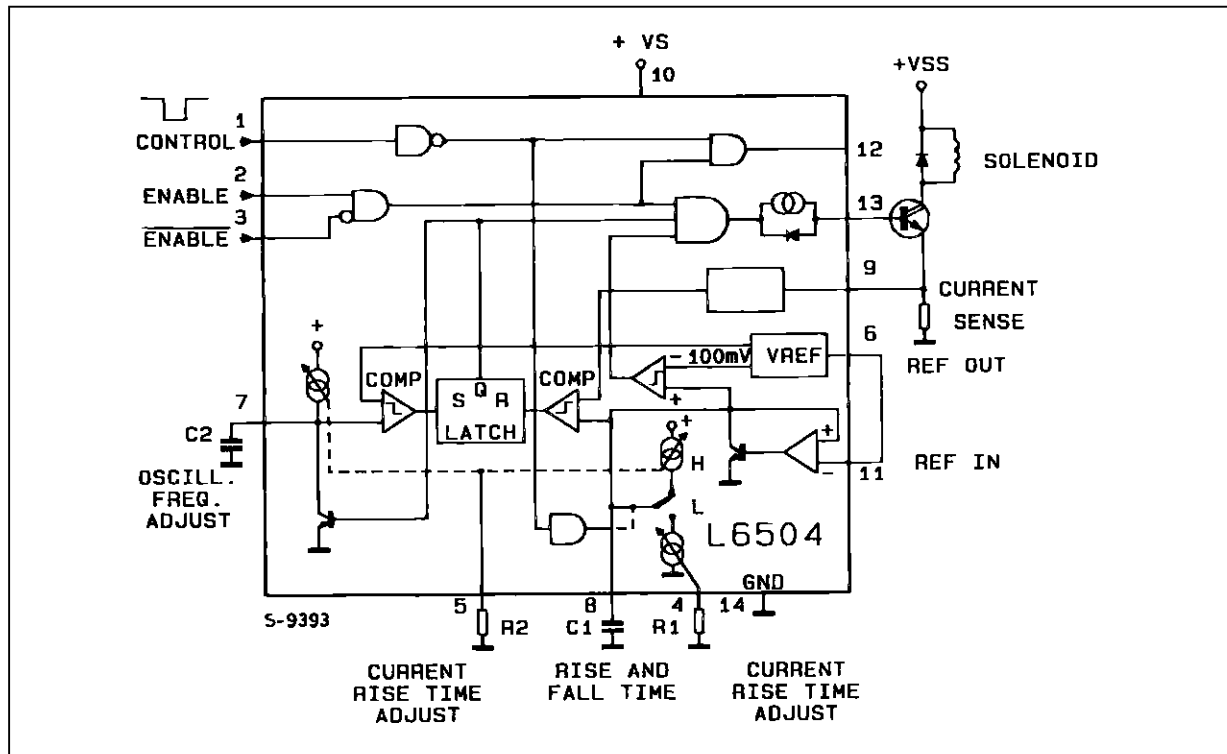

**ABSOLUTE MAXIMUM RATINGS**

Symbol	Parameter	Test Conditions	Unit
V <sub>S</sub>	DC Supply Voltage	10	V
V <sub>2,3</sub>	Enable Input Voltage Range	-0.3 to 7	V
V <sub>1</sub>	Control Input Voltage Range	-0.3 to 7	V
V <sub>9</sub>	Sense Voltage	-0.3 to 2	V
I <sub>6</sub>	Reference Output Current	2	mA
V <sub>11</sub>	External Reference Voltage	2	V
T <sub>stg</sub>	Storage Temperature	-55 to 150	°C
T <sub>j</sub>	Junction Temperature	-55 to 150	°C
T <sub>op</sub>	Operating Temperature	0 to 85	°C

**THERMAL DATA**

Symbol	Parameter	Test Conditions	Unit
R <sub>th j-amb</sub>	Thermal Resistance Junction-ambient	Max. 100	°C/W

**ELECTRICAL CHARACTERISTICS**

N°	Symbol	Parameter	Pin	Test Conditions	Min.	Typ.	Max.	Unit
1	V <sub>s</sub>	Operating Supply Voltage	10		4.5		10	V
2	V <sub>sth</sub>	Supply Voltage Threshold For Output Switch-off	10	V <sub>CH</sub> = LOW, V <sub>E</sub> = HIGH	2.96	3.7	4.45	V
3	I <sub>s</sub>	Quiescent Current	10	Pin1 Highstate		7	12	mA
4	V <sub>CL</sub>	Control Voltage	1	Low State			1.5	V
5	V <sub>CH</sub>	Control Voltage	1	High State	2.3			V
6	I <sub>CL</sub>	Control Input Current	1	V <sub>1</sub> Low State	-1		0	mA
7	I <sub>CH</sub>	Control Input Current	1	V <sub>1</sub> High State	-0.6		5	uA
8	V <sub>EL</sub>	Enable Voltage	2/3	Low State			1.5	V
9	V <sub>EH</sub>	Enable Voltage	2/3	High State	2.3			V
10	I <sub>IN</sub>	Input Current	2/3	V <sub>2,3</sub> Low State	-10		1	μA
11	I <sub>IN</sub>	Input Current	2/3	V <sub>2,3</sub> High State	-1		5	μA
12	V <sub>DL</sub>	Driving Voltage Low	13	R <sub>13,14</sub> = 5kΩ, Low State			0.5	V
13	I <sub>D</sub>	Driving Current	13	V <sub>13</sub> = 2V	6.5	10	16	mA
14	V <sub>SE</sub>	Sense Voltage	9		0		2	V
15	V <sub>ref</sub>	Reference Voltage	6	I <sub>6</sub> = 0...2mA	1.28	1.33	1.38	V
16	I <sub>ref</sub>	Reference Current	6				2	mA
17	V <sub>RIN</sub>	Reference Input	11		0.3		2	V
18	I <sub>C8</sub>	Charge Current	8	R <sub>2</sub> (Pin5) = 20kΩ, Pin1L	58	65	72	μA
19	I <sub>D8</sub>	Discharge Current	8	R <sub>1</sub> (Pin4) = 20kΩ, Pin1H	28	32.5	37	μA
20	I <sub>SD</sub>	Source Current	12	V <sub>12</sub> = 2V	0.5	1	1.6	mA
21	V <sub>sats</sub>	Source Saturation Voltage	12	I <sub>SOURCE</sub> = 0.5mA			1.2	V
22	V <sub>sats</sub>	Sink Saturation Voltage	12	I <sub>SINK</sub> = 2mA			0.4	V
23	V <sub>V-I</sub>	VI-Converter Voltage	4/5	10kΩ < R <sub>1,2</sub> < 200kΩ, R <sub>1</sub> = R <sub>2</sub>	1.26	1.32	1.4	V
24	t <sub>r</sub>	Recirculation Time of Load Current	7	C <sub>2</sub> = 1.5ns, R <sub>2</sub> = 20kΩ	27	30	33	μs
25	t <sub>D</sub>	Current Sense Delay Time	9		0.3	1	2.5	μs

Figure 1 : Timing Diagram Start Phase

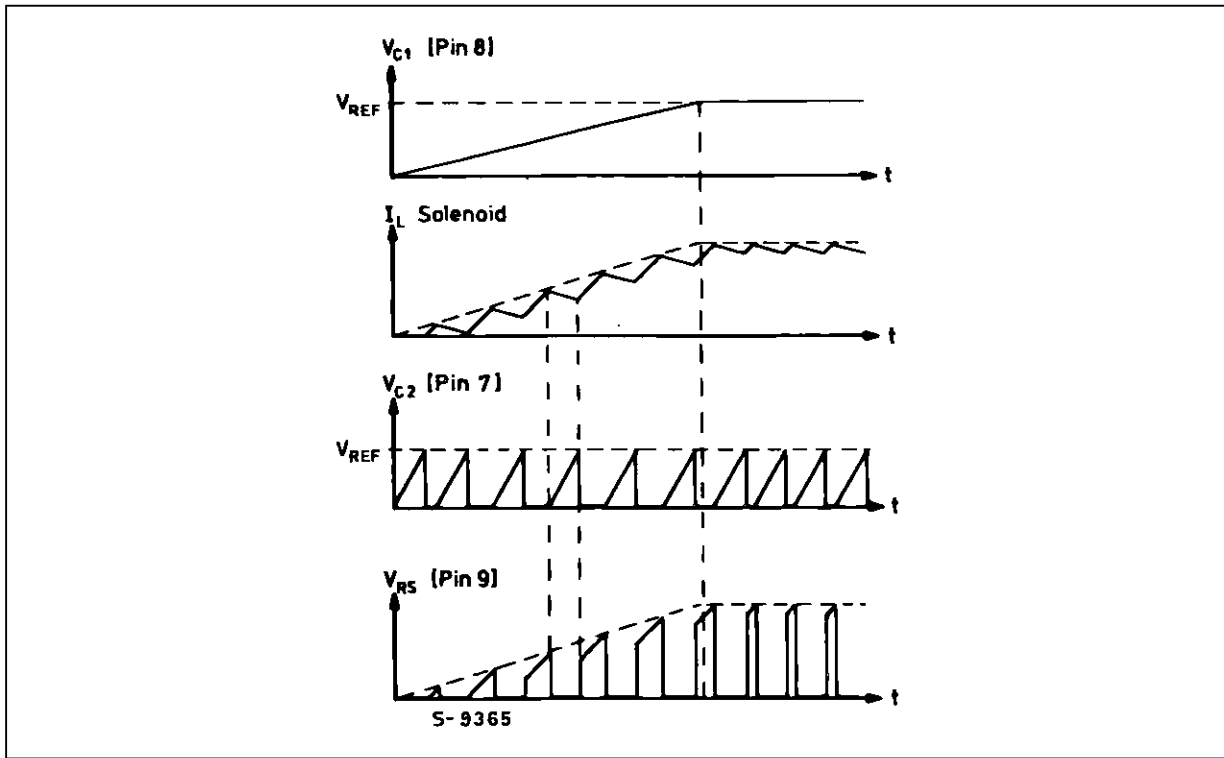

APPLICATION INFORMATION

Figure 2 : Free Running Load Current Leading and Trailing Edge

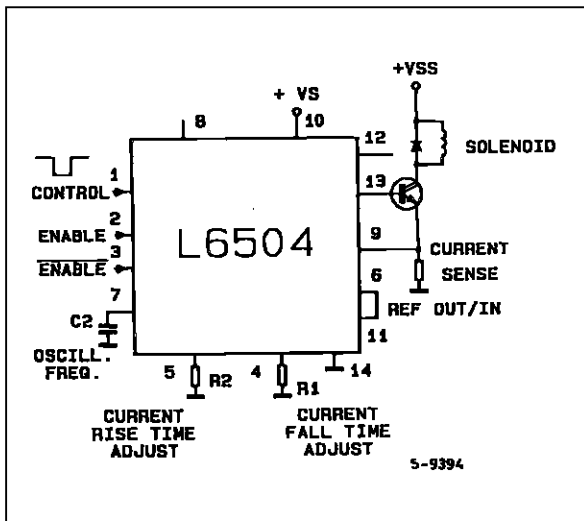

Figure 3 :

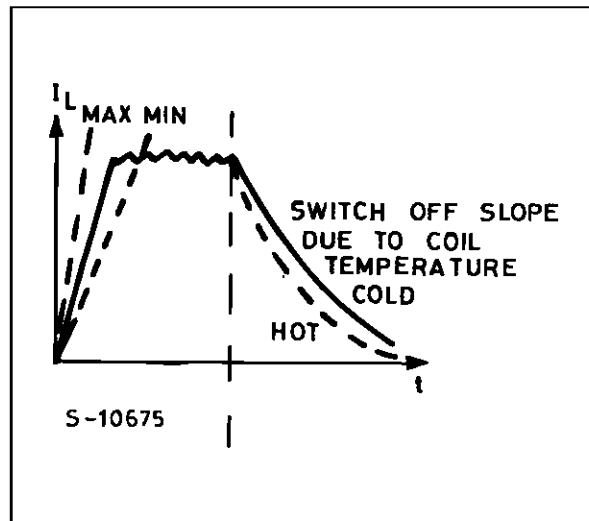

Figure 4 : Slew Rate of Loading Edge Controlled

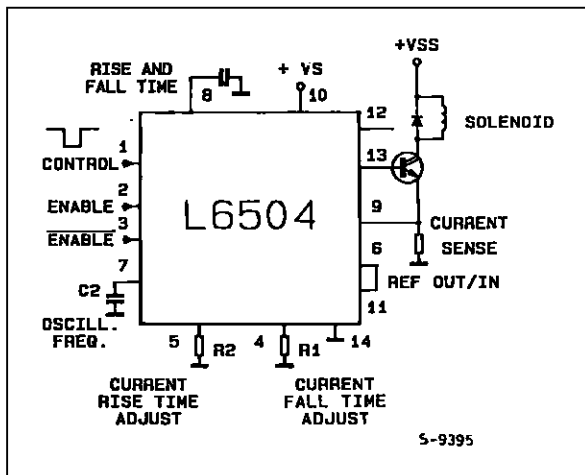

Figure 5 :

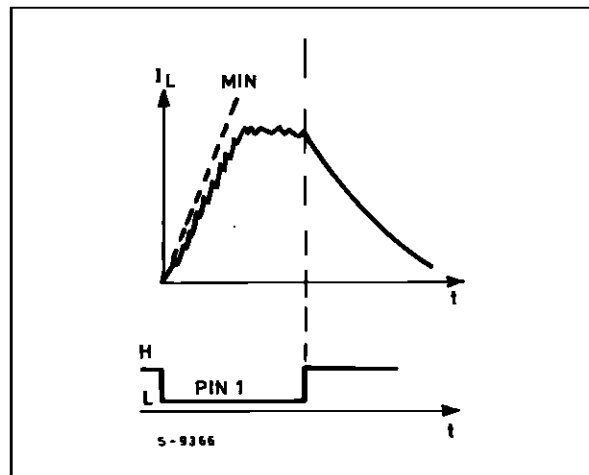

Figure 6 : Slew Rate Leading and Trailing Edge Controlled

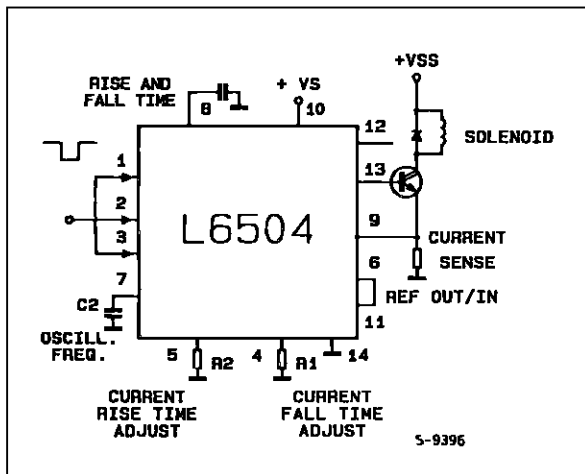

Figure 7 :

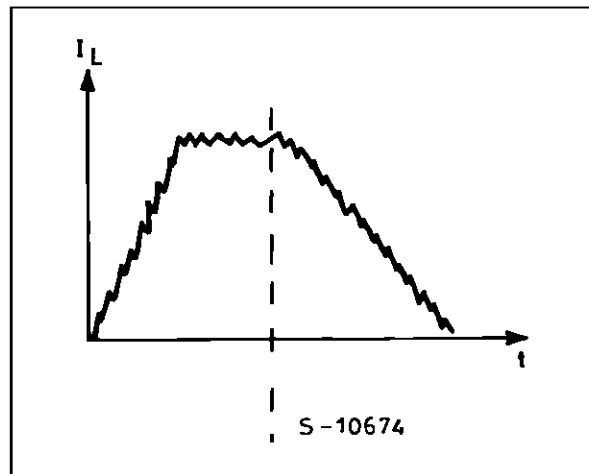

Figure 8 : Free Running Leading Edge Fast Current Slope at Trailing Edge

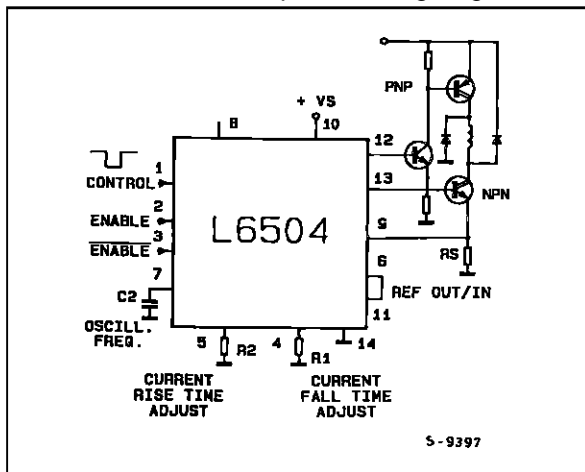
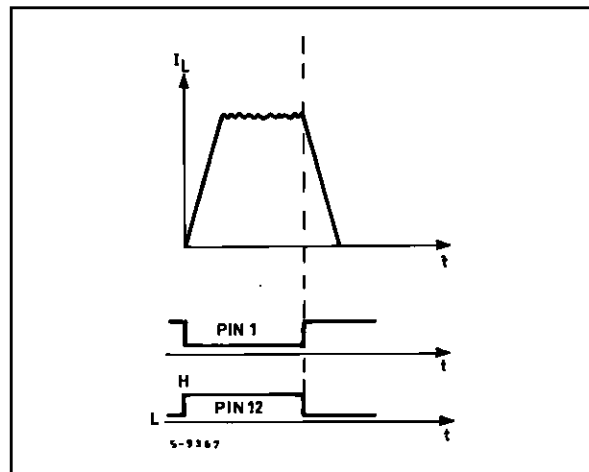
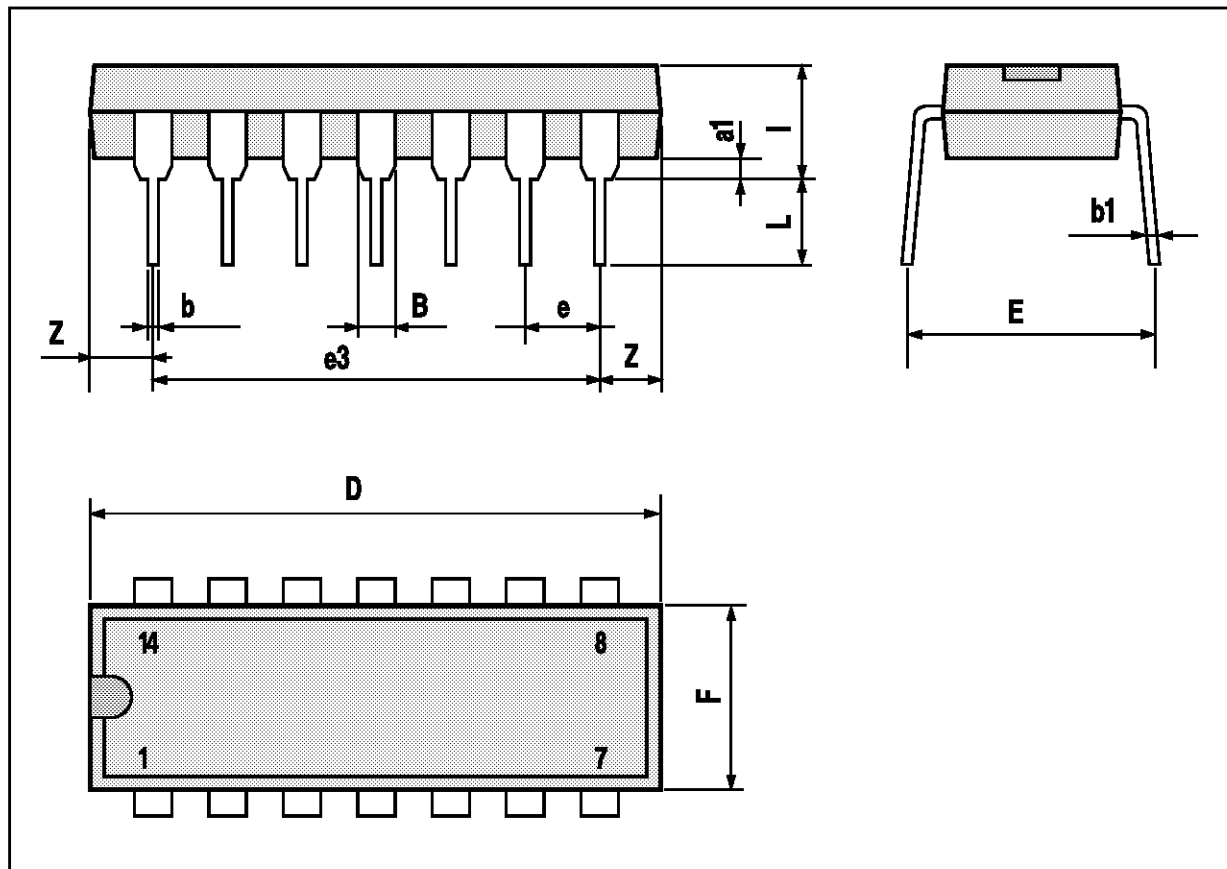

Figure 9 :



DIP14 PACKAGE MECHANICAL DATA

DIM.	mm			inch		
	MIN.	TYP.	MAX.	MIN.	TYP.	MAX.
a1	0.51			0.020		
B	1.39		1.65	0.055		0.065
b		0.5			0.020	
b1		0.25			0.010	
D			20			0.787
E		8.5			0.335	
e		2.54			0.100	
e3		15.24			0.600	
F			7.1			0.280
I			5.1			0.201
L		3.3			0.130	
Z	1.27		2.54	0.050		0.100



Information furnished is believed to be accurate and reliable. However, SGS-THOMSON Microelectronics assumes no responsibility for the consequences of use of such information nor for any infringement of patents or other rights of third parties which may result from its use. No license is granted by implication or otherwise under any patent or patent rights of SGS-THOMSON Microelectronics. Specifications mentioned in this publication are subject to change without notice. This publication supersedes and replaces all information previously supplied. SGS-THOMSON Microelectronics products are not authorized for use as critical components in life support devices or systems without express written approval of SGS-THOMSON Microelectronics.

© 1994 SGS-THOMSON Microelectronics - All Rights Reserved

SGS-THOMSON Microelectronics GROUP OF COMPANIES

Australia - Brazil - France - Germany - Hong Kong - Italy - Japan - Korea - Malaysia - Malta - Morocco - The Netherlands - Singapore - Spain - Sweden - Switzerland - Taiwan - Thailand - United Kingdom - U.S.A.