

HIGH VOLTAGE HALF BRIDGE DRIVER WITH OSCILLATOR

PRELIMINARY DATA

- TECHNOLOGY: BCD "OFF-LINE"
- FLOATING SUPPLY VOLTAGE UP TO 600V
- GND REFERRED SUPPLY VOLTAGE UP TO 18V
- DRIVER CURRENT CAPABILITY:
 - SINK CURRENT = 270mA
 - SOURCE CURRENT = 170mA
- VERY LOW START UP CURRENT: 150µA
- VERY LOW OPERATING CURRENT: <2mA
- UNDERVOLTAGE LOCKOUT
- PROGRAMMABLE OSCILLATOR FREQUENCY
- dV/dt IMMUNITY UP TO ± 50V/ns

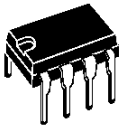

Minidip

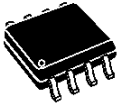

SO8

ORDERING NUMBERS:

L6569/L6569A	L6569D/L6569AD
--------------	----------------

DESCRIPTION

The device is a high voltage half bridge driver with built-in oscillator. The frequency of the oscillator can be programmed using external resistor

and capacitor.

The output drivers are designed to drive external n-channel power MOSFET and IGBT. The internal logic assures a minimum dead time to avoid cross-conduction of the power devices.

BLOCK DIAGRAM

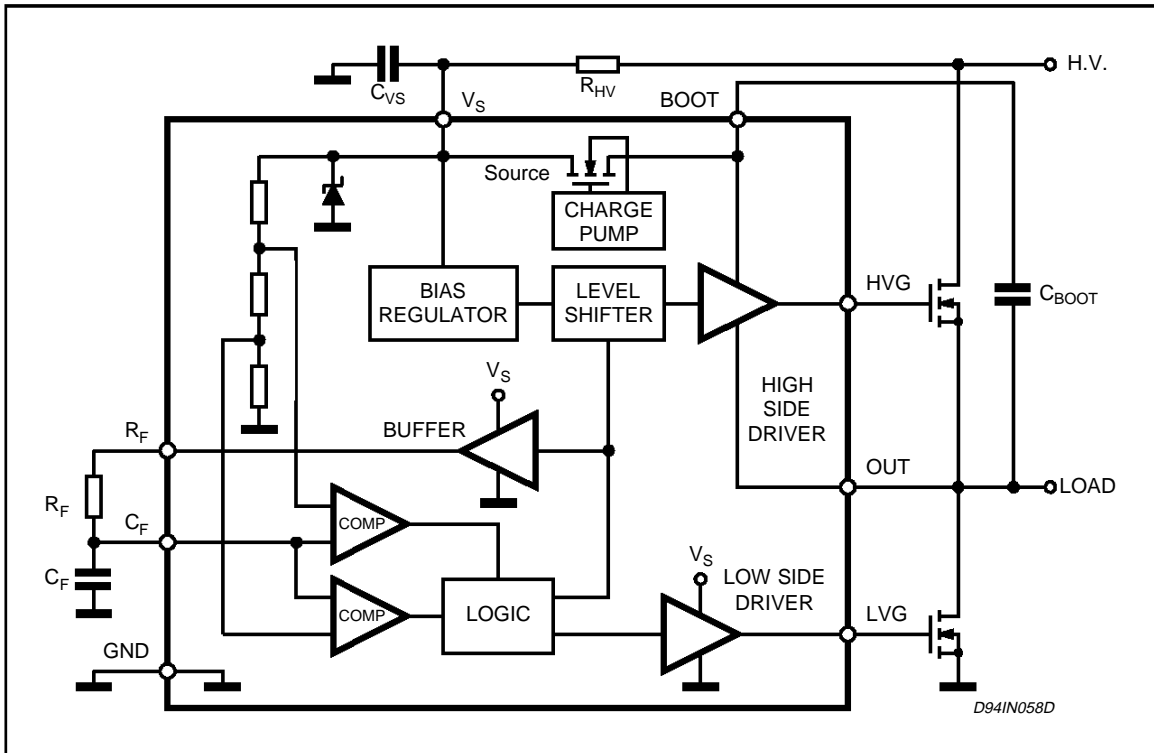

ABSOLUTE MAXIMUM RATINGS

Symbol	Parameter	Value	Unit
I_S (*)	Supply Current	25	mA
V_{CF}	Oscillator Resistor Voltage	18	V
V_{LVG}	Low Side Switch Gate Output	14.6	V
V_{OUT}	High Side Switch Source Output	-1 to $V_{BOOT} - 18$	V
V_{HVG}	High Side Switch Gate Output	-1 to V_{BOOT}	V
V_{BOOT}	Floating Supply Voltage	618	V
V_{BOOT}/OUT	Floating Supply vs OUT Voltage	18	V
dV_{BOOT}/dt	V_{BOOT} Slew Rate (Repetitive)	± 50	V/ns
dV_{OUT}/dt	V_{OUT} Slew Rate (Repetitive)	± 50	V/ns
T_{stg}	Storage Temperature	-40 to 150	°C
T_j	Junction Temperature	-40 to 150	°C
T_{amb}	Ambient Temperature (Operative)	-40 to 125	°C

(*)The device has an internal zener clamp between GND and V_S (typical 15.6V).
Therefore the circuit should not be driven by a DC low impedance power source.

Note: ESD immunity for pins 6, 7 and 8 is guaranteed up to 900 V (Human Body Model)

THERMAL DATA

Symbol	Parameter	Minidip	SO8	Unit
$R_{th\ j-amb}$	Thermal Resistance Junction-Ambient	Max	150	°C/W

RECOMMENDED OPERATING CONDITIONS

Symbol	Parameter	Min.	Max.	Unit
V_S	Supply Voltage	10	V_{CL}	V
V_{BOOT}	Floating Supply Voltage	-	500	V
V_{OUT}	High Side Switch Source Output	-1	$V_{BOOT} - V_{CL}$	V
f_{out}	Oscillation Frequency		200	kHz

PIN CONNECTION

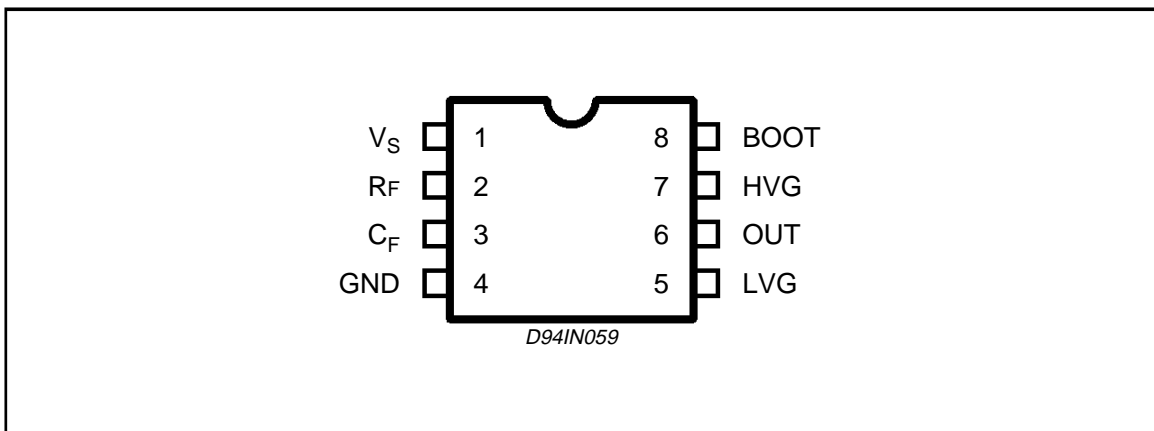

ELECTRICAL CHARACTERISTICS ($V_S = 12V$; $V_{BOOT} - V_{OUT} = 12V$; $T_j = 25^\circ C$; unless otherwise specified.)

Symbol	Pin	Parameter	Test Condition	Min.	Typ.	Max.	Unit
V_{SUVp}	1	V_S Turn On Threshold		8.3	9	9.7	V
V_{SUVN}		V_S Turn Off Threshold		7.3	8	8.7	V
V_{SUVH}		V_S Hysteresis		0.7	1	1.3	V
V_{CL}		V_S Clamping Voltage	$I_S = 5mA$	14.6	15.6	16.6	V
I_{SU}		Start Up Current	$V_S < V_{SUVN}$		150	250	μA
I_q		Quiescent Current	$V_S > V_{SUVp}$		500	700	μA
I_{BOOTLK}		8	Leakage Current BOOT pin vs GND	$V_{BOOT} = 580V$			5
I_{OUTLK}	6	Leakage Current OUT pin vs GND	$V_{OUT} = 562V$			5	μA
$I_{HVG SO}$	7	High Side Driver Source Current	$V_{HVG} = 6V$	110	175		mA
$I_{HVG SI}$		High Side Driver Sink Current	$V_{HVG} = 6V$	190	275		mA
$I_{LVG SO}$	5	Low Side Driver Source Current	$V_{LVG} = 6V$	110	175		mA
$I_{LVG SI}$		Low Side Driver Sink Current	$V_{LVG} = 6V$	190	275		mA
V_{RFON}	2	RF High Level Output Voltage	$I_{RF} = 1mA$	$V_S - 0.05$		$V_S - 0.2$	V
V_{RFOFF}		RF Low Level Output Voltage	$I_{RF} = -1mA$	50		200	mV
V_{CFU}	3	CF Upper Threshold		7.7	7.95	8.2	V
V_{CFL}		CF Lower Threshold		3.80	4.05	4.3	V
t_d		Internal Dead Time		0.85	1.25	1.65	μs
D_C		Duty Cycle, Ratio Between Dead Time + Conduction Time of High Side and Low Side Drivers		0.45	0.5	0.55	
R_{ON}		On resistance of Bootstrap LDMOS			120		Ω
V_{BC}		Bootstrap Voltage before UVLO	$V_S = 8.2$	2.5	3.6		V
I_{AVE}	1	Average Current from V_S	No Load, $f_s = 60KHz$		1.2	1.5	mA
f_{out}	6	Oscillation Frequency	$R_T = 12k$ $C_T = 1nF$	57	60	63	kHz

OSCILLATOR FREQUENCY

The frequency of the internal oscillator can be programmed using external resistor and capacitor. The nominal oscillator frequency can be calculated using the following equation:

$$f_{OSC} = \frac{1}{2 \cdot R_F \cdot C_F \cdot \ln 2} = \frac{1}{1.3863 \cdot R_F \cdot C_F}$$

where R_F and C_F are the external resistor and capacitor

Bootstrap Function

The L6569 has an internal Bootstrap structure that enables the user to avoid the external diode needed, in similar devices, to perform the charge of the bootstrap capacitor that, in turns, provide an appropriate driving to the Upper External Mosfet. The operation is achieved with an unique structure (patent pending) that uses a High Voltage Lateral DMOS driven by an internal charge

pump (see Block Diagram) and synchronized, with a 50 nsec delay, with the Low Side Gate driver (LVG pin), actually working as a synchronous rectifier. The charging path for the Bootstrap capacitor is closed via the Lower External Mosfet that is driven ON (i.e. LVG High) for a time interval:

$$T_C = R_F \cdot C_F \cdot \ln 3 \cong 1.1 R_F \cdot C_F$$

starting from the time the Supply Voltage V_S has reached the Turn On Voltage ($V_{sup} = 9V$ typical value).

After time T_1 (see Waveform Diagram) the LDMOS that charges the Bootstrap Capacitor, is saturated with a $R_{on} = 120 \text{ ohm}$ (typical value).

In the L6569A a different start up procedure is followed (see Waveform Diagram). The Lower External Mosfet is drive OFF until V_S has reached the Turn On Threshold (V_{sup}), then again the T_C time interval starts as above.

L6569/L6569A

Being the LDMOS used to implement the bootstrap operation a "bidirectional" switch the current flowing into the Vboot pin can lead an undue stress to the LDMOS itself if a ZERO VOLTAGE SWITCHING operations not ensured, and then an high voltage is applied to the Vboot pin. This condition can occur, for example, when the load is removed or when an high resistive value is placed in series with the gate of the external Power Mos. To help the user to secure his design a SAFE OPERATING AREA for the Bootstrap LDMOS is provided (fig. 6). Let's consider the steps that should be taken.

- 1) Calculate the Turn on delay (td) of your Lower Power MOS:

$$t_d = (R_g + R_{id}) \cdot C_{iss} \ln(1/(1-V_{TH}/V_S))$$

- 2) Calculate the Fall time (tf) of your Lower Power MOS:

$$t_f = (V_S - V_{TH}) / (R_g + R_{id}) \cdot Q_{gd}$$

where:

R_g = External gate resistor

R_{id} = 50 ohm , typical equivalent output resistance of the driving buffer (when sourcing current)

V_{TH}, C_{iss} and Q_{gd} are Power MOS parameters

V_S = Low Voltage Supply.

- 3) Sketch the Vboot waveform (using log-log scales) starting from the Drain Voltage of the

Lower Power MOS (remember to add the V_s, your Low Voltage Supply, value) on the Bootstrap LDMOS SOA . On fig. 7 an example is given where:

$$V_s = \text{Low Voltage Supply}$$

$$V_{HV} = \text{High Voltage Supply Rail}$$

The Vboot voltage swing must fall below the curve identified by the actual operating frequency of your application.

DEMO BOARD

To allow an easy evaluation of the device, a P.C. board dedicated to lamp ballast application has been designed.

Fig.10 shows the electrical schematic of a typical ballast application, while the PC and component layout is given in Fig11. This application has been designed to work with both the 110+/-20%V and the 220 +/- 20%V mains by means of a voltage doubler configuration at the bulk capacitor. The ballast inductance and the operating frequency are especially designed for a 18 W Sylvania Deluxe T/E type bulb. The PTC for preheat at the start up and the two back to back synchronization diodes, makes this application easy to implement and safe in operation.

Figure 1: WAVEFORMS (L6569)

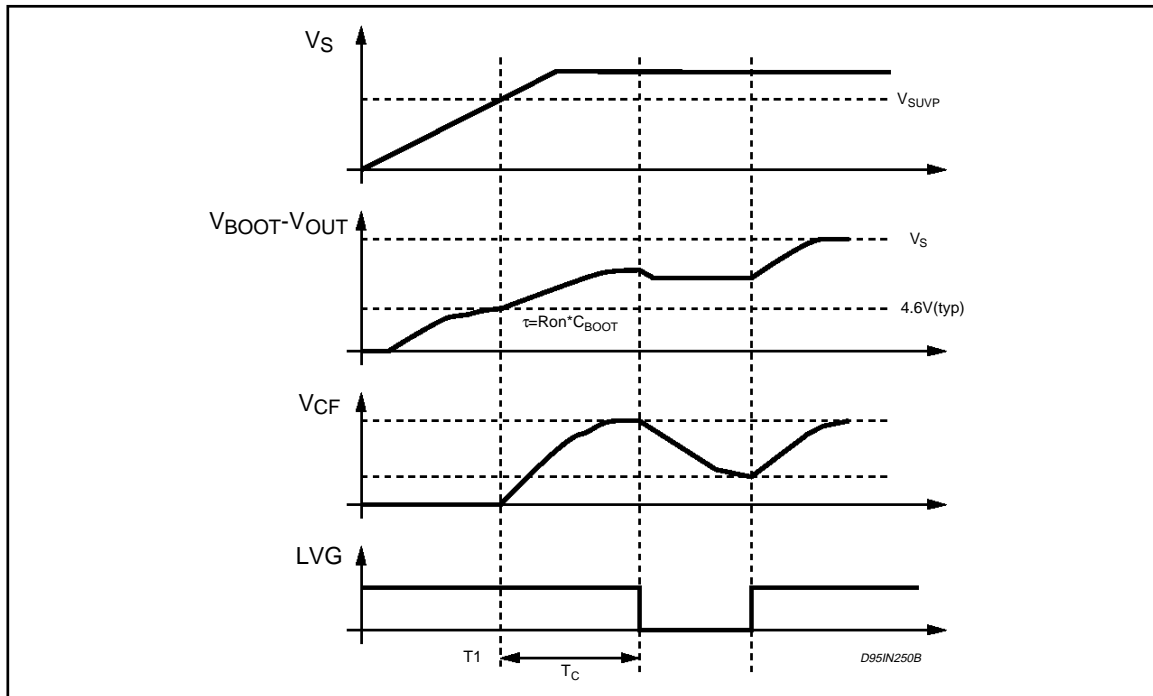

Figure 2: WAVEFORMS (L6569A)

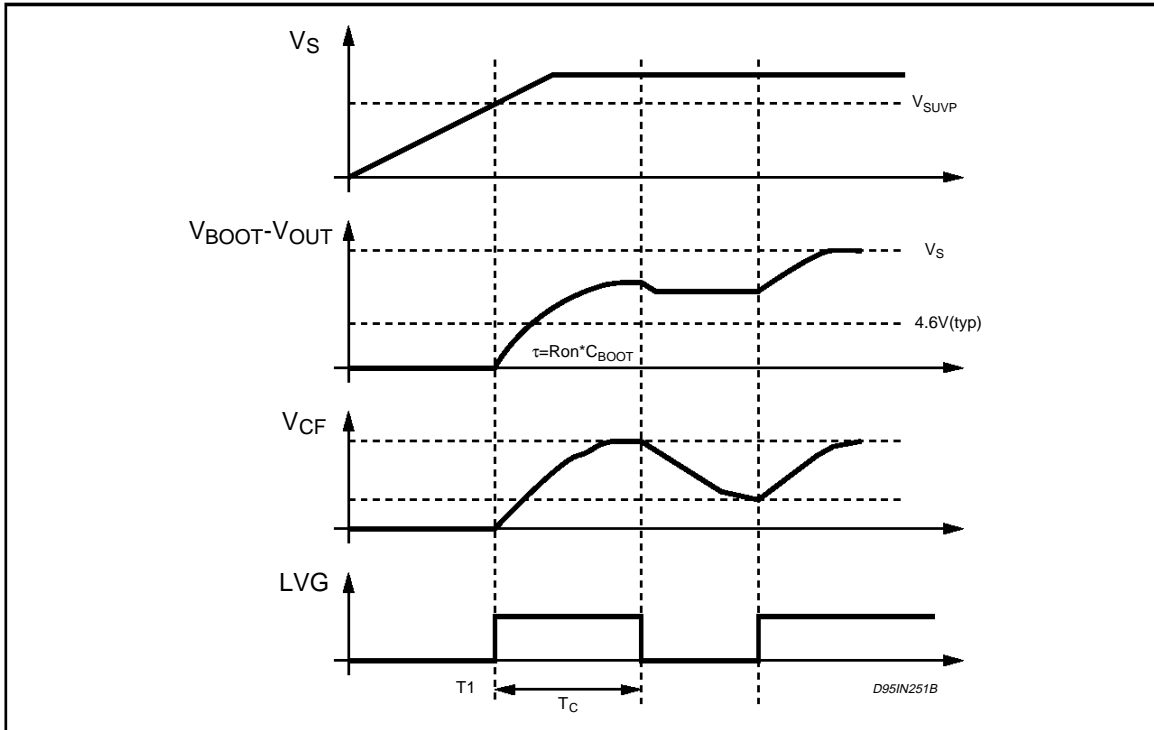

Figure 3: Typical Dead Time vs. Temperature Dependency

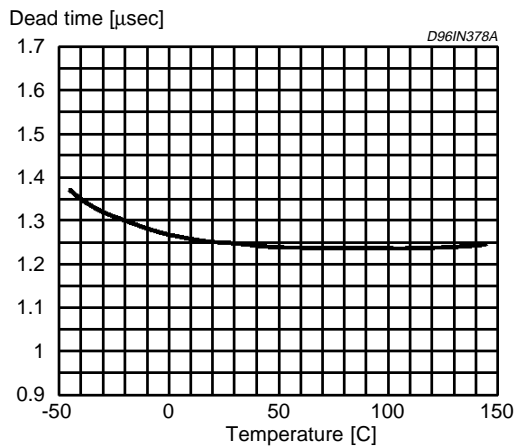

Figure 4: Typical Frequency vs. Temperature Dependency

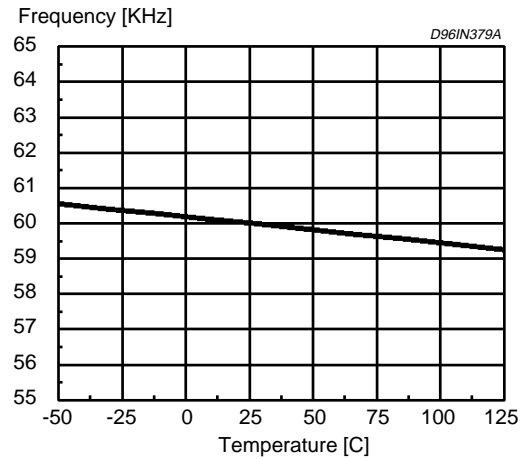

Figure 5: Typical and Theoretical Oscillator Frequency vs Resistor Value

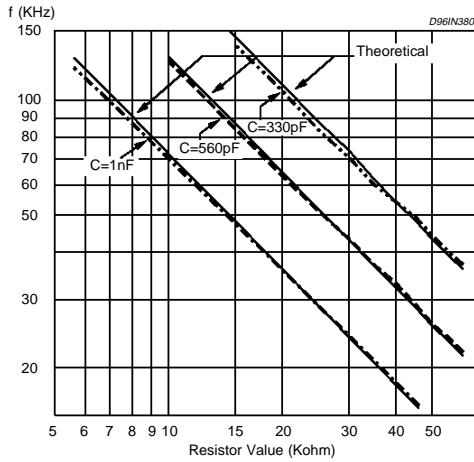

Figure 6: V_{boot} pin SOA for different Operating Frequency @ $T_j = 125^\circ C$

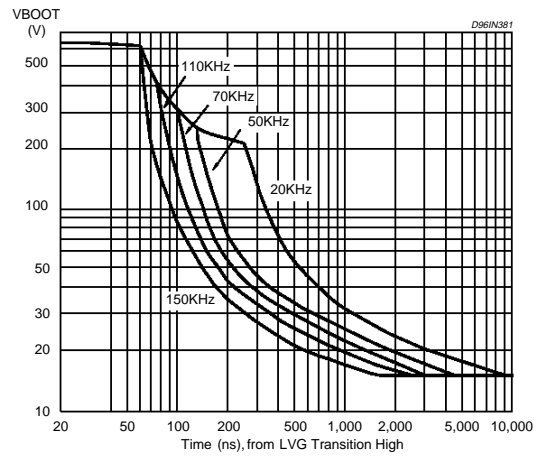

Figure 7: V_{boot} pin SOA for different Operating Frequency @ $T_j = 125^\circ C$

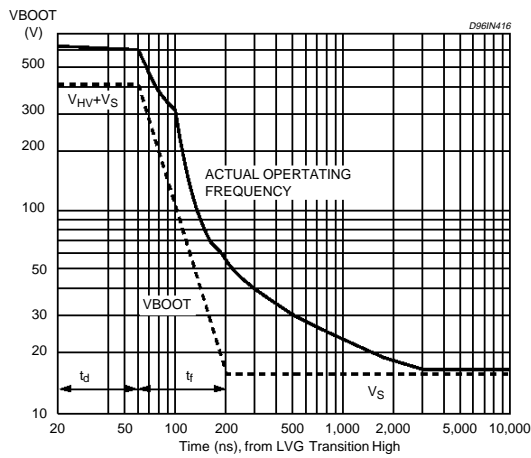

Figure 8: Typical Rise and Fall Times vs. Load Capacitance

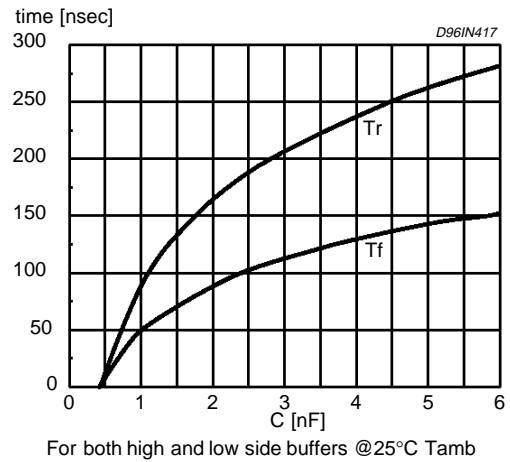
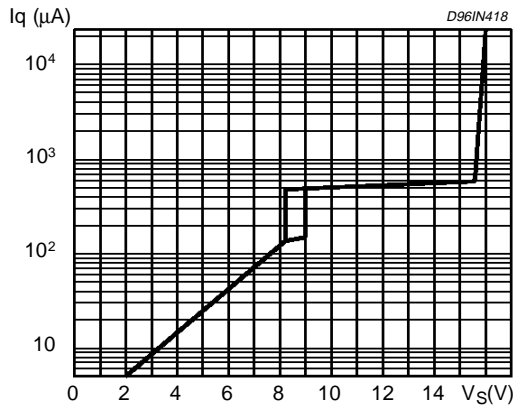
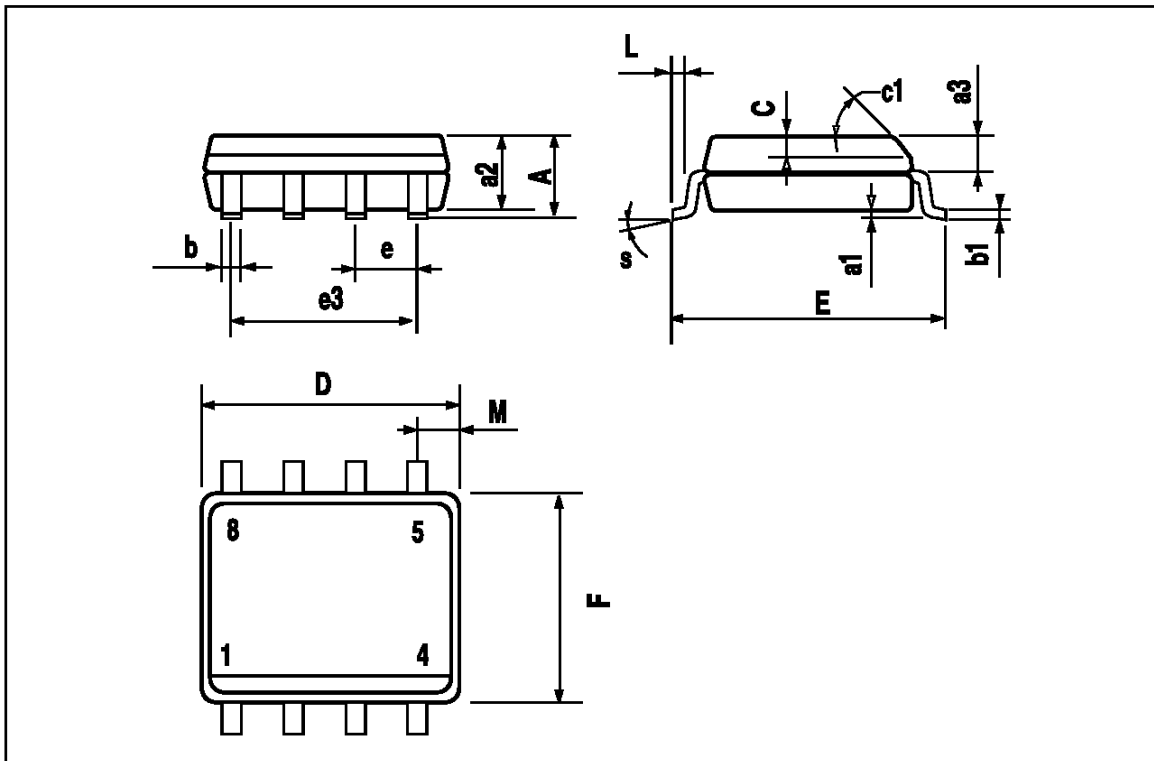

Figure 9: Quiescent Current vs. Supply Voltage.



SO8 PACKAGE MECHANICAL DATA

DIM.	mm			inch		
	MIN.	TYP.	MAX.	MIN.	TYP.	MAX.
A			1.75			0.069
a1	0.1		0.25	0.004		0.010
a2			1.65			0.065
a3	0.65		0.85	0.026		0.033
b	0.35		0.48	0.014		0.019
b1	0.19		0.25	0.007		0.010
C	0.25		0.5	0.010		0.020
c1	45° (typ.)					
D	4.8		5.0	0.189		0.197
E	5.8		6.2	0.228		0.244
e		1.27			0.050	
e3		3.81			0.150	
F	3.8		4.0	0.15		0.157
L	0.4		1.27	0.016		0.050
M			0.6			0.024
S	8° (max.)					



MINIDIP PACKAGE MECHANICAL DATA

DIM.	mm			inch		
	MIN.	TYP.	MAX.	MIN.	TYP.	MAX.
A		3.32			0.131	
a1	0.51			0.020		
B	1.15		1.65	0.045		0.065
b	0.356		0.55	0.014		0.022
b1	0.204		0.304	0.008		0.012
D			10.92			0.430
E	7.95		9.75	0.313		0.384
e		2.54			0.100	
e3		7.62			0.300	
e4		7.62			0.300	
F			6.6			0.260
I			5.08			0.200
L	3.18		3.81	0.125		0.150
Z			1.52			0.060

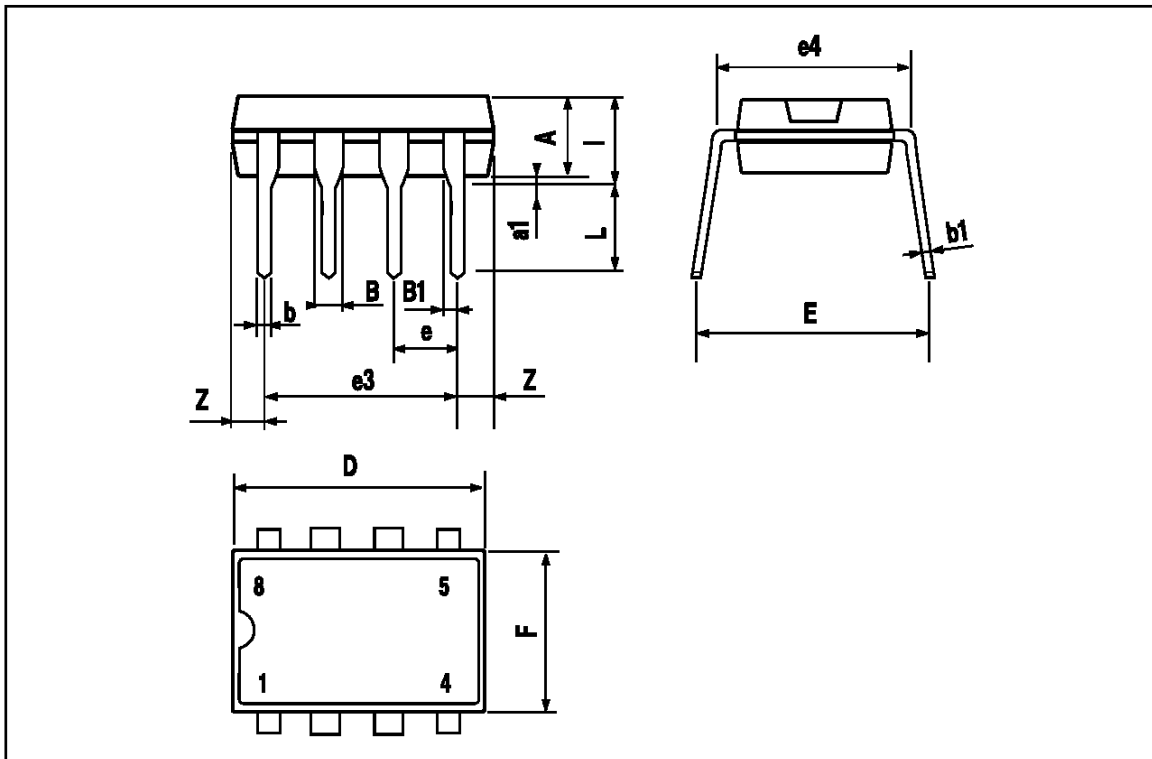

Information furnished is believed to be accurate and reliable. However, SGS-THOMSON Microelectronics assumes no responsibility for the consequences of use of such information nor for any infringement of patents or other rights of third parties which may result from its use. No license is granted by implication or otherwise under any patent or patent rights of SGS-THOMSON Microelectronics. Specifications mentioned in this publication are subject to change without notice. This publication supersedes and replaces all information previously supplied. SGS-THOMSON Microelectronics products are not authorized for use as critical components in life support devices or systems without express written approval of SGS-THOMSON Microelectronics.

© 1996 SGS-THOMSON Microelectronics - All Rights Reserved

SGS-THOMSON Microelectronics GROUP OF COMPANIES

Australia - Brazil - France - Germany - Hong Kong - Italy - Japan - Korea - Malaysia - Malta - Morocco - The Netherlands - Singapore - Spain - Sweden - Switzerland - Taiwan - Thailand - United Kingdom - U.S.A.