

DOUBLE QUAD CONTACT INTERFACE CIRCUIT

ADVANCE DATA

- OPERATING DC SUPPLY VOLTAGE RANGE 5V TO 25V
- SUPPLY OVERVOLTAGE PULSE UP TO 40V
- VERY LOW STAND-BY QUIESCENT CURRENT, MAX 50 μ A
- INTERNAL CLAMPING DIODES AT CONTACT INPUTS TO V_s AND gnd WITH PULSE CURRENT CAPABILITY UP TO +50mA, -75mA
- CHIP ENABLE FUNCTION AND TRISTATE OUTPUTS FOR PARALLEL BUS CONNECTION
- NOMINAL CONTACT CURRENTS OF 10mA DEFINED WITH EXTERNAL CONTACT SERIES RESISTORS R_{IN1-8}
- CONTACT STATUS MONITORING BY MEANS OF COMPARING THE RESISTANCE AT CONTACT SENSE INPUTS WITH THE INTERNAL REFERENCE RESISTOR VALUE
- RESISTANCE COMPARING WITH HYSTERESIS FOR HIGH NOISE IMMUNITY AND IMMUNITY TO GROUND AND BATTERY POTENTIAL DIFFERENCES

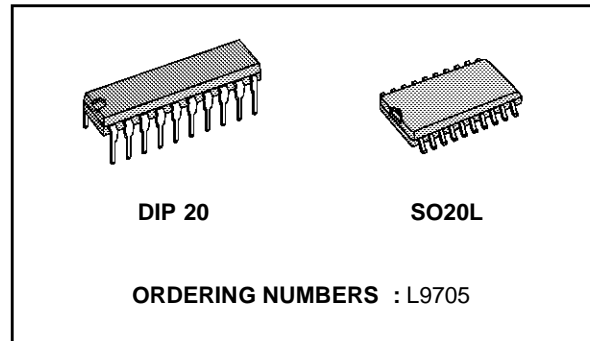

DESCRIPTION

The L9705 is a bipolar monolithic integrated circuit for monitoring the status of up to four contacts connected to GND and up to four contacts connected to the battery. The contact sense input supply the contact current and perform the contact resistance comparison function.

At the output the contact status is translated into a logical LOW level (contact closed) or logical HIGH level (contact open).

BLOCK DIAGRAM

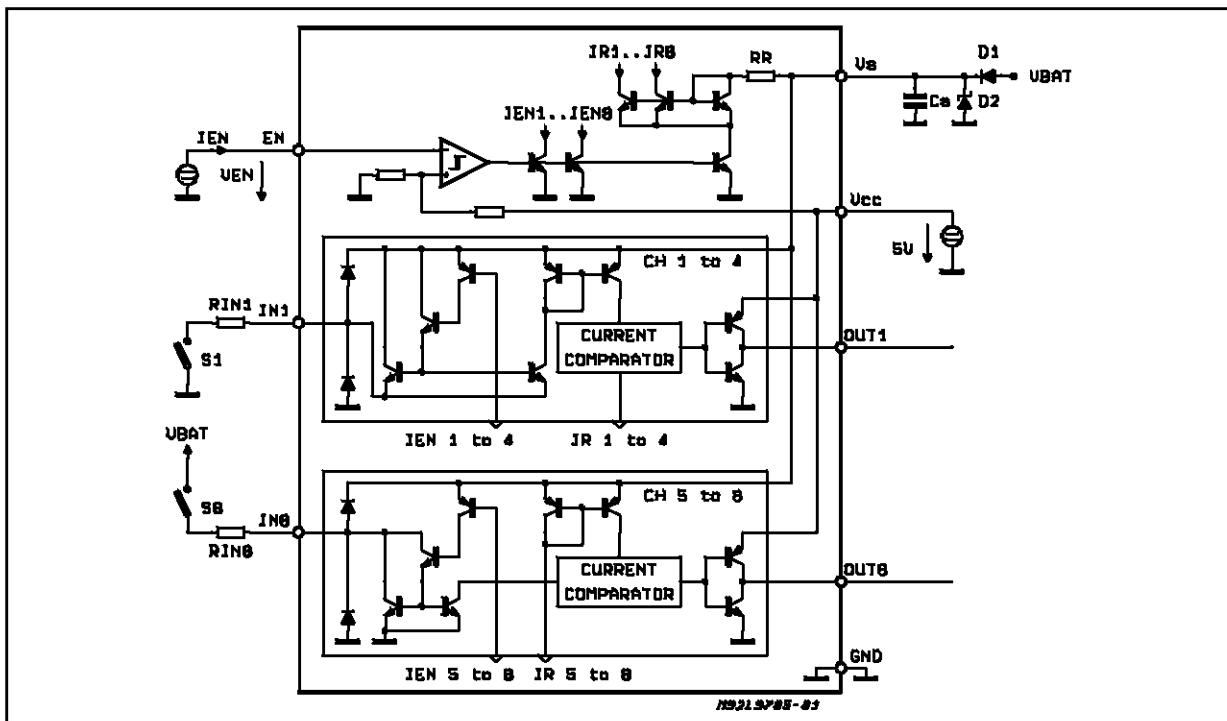

ABSOLUTE MAXIMUM RATINGS

Symbol	Parameter	Value	Unit
V _{SDC}	DC Supply Voltage	+26	V
V _{SP}	Peak Transient Supply Voltage (t ≤ 400ms)	+40	V
V _{CC}	Logic Supply Voltage	7	V
I _{INDC}	Input DC Current	±40	mA
I _{INP}	Input Pulse (t _p = 0 to 2ms; f ≤ 0.2Hz; n = 25000)	-75 to 50	mA
I _{OUT}	Output Current (V _O = 0 to 5.5V)	internally limited	
V _{EN}	Enable Input Voltage	V _{CC} +0.3V;-0.3V	V
P _{tot}	Total Power Dissipation (T _{amb} = 80°C) DIP 20 SO 20	875 420	mW mW
T _j	Junction Temperature Range	max150	°C

PIN CONNECTION (top view)

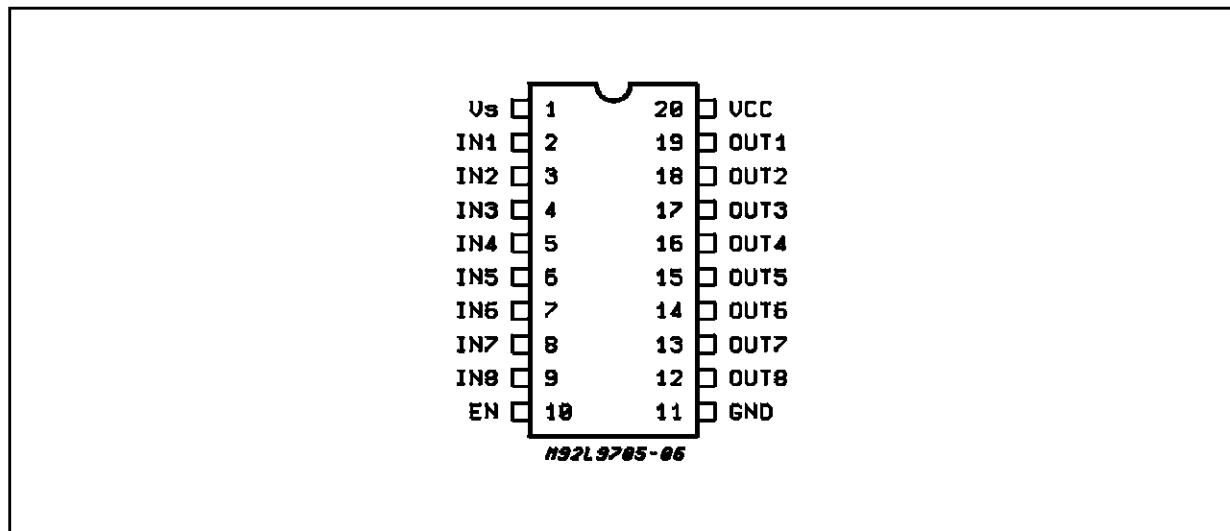

THERMAL DATA

Symbol	Description	DIP20	SO20L	Unit
R _{th j-amb}	Thermal Resistance Junction-ambient	80		°C/W
R _{th j-amb}	Thermal Resistance Junction-ambient		165	°C/W

ELECTRICAL CHARACTERISTICS ($V_S = 5$ to $25V$, $V_{CC} = 4.75$ to $5.25V$, $V_{bat} - 0.5V \leq V_S \leq V_{bat} - 1V$, $T_j = -40$ to $150^\circ C$ unless otherwise specified.)

Symbol	Parameter	Test Condition	Min.	Typ.	Max.	Unit
V_{ENL}	Enable Input Voltage LOW (device activated)		-0.3		0.8	V
V_{ENH}	Enable Input Voltage HIGH		2.4		V_{CC}	V
V_{ENh}	Enable Input Threshold Hysteresis		200	420	800	mV
I_{EN}	Enable Input Current	$2.4V < V_{EN} < V_{CC}$ $0V < V_{EN} < 0.8V$	-5	-1	5	μA μA
V_{OUTH}	Output Voltage HIGH	$0 < I_{OUT} < 100\mu A$	4	$V_{CC} - 0.1$	V_{CC}	V
I_{OUT}	Output Current	OUT status = HIGH; $V_{OUT} = 0$		0.5	2	mA
V_{OUTL}	Output Voltage LOW	$I_{OUT} = -1mA$	0.05	0.2	0.4	V
I_{OUT}	Output Current	OUT status = LOW; $V_{OUT} = 5.5V$		-5	-20	mA
$I_{OUT TS}$	Output Tristate Current	$0 < V_{OUT} < V_{CC}$			0.5	μA
$V_{IN 1,4}$	Input Voltage (device active)	EN = LOW; $R_{IN} = 1K\Omega$	$V_S - 2$	$V_S - 1.5$	$V_S - 0.4$	V
$V_{IN 5,8}$	Input Voltage (device active)	EN = LOW; $R_{IN} = 1K\Omega$	0.4	1.5	2	V
V_{IN}	Input Voltage During Clamp (device disabled)	EN = HIGH; $I_{IN} = 30mA$ $I_{IN} = -30mA$	$V_S + 0.3$ -2	$V_S + 1$ -1	$V_S + 2$ -0.3	V V
$R_{IL 1,4}$	Input Resistor LOW Threshold (note 1)	$5V < V_S < 16V$; $ \Delta V_{GND} \leq 0.1V_S$ $ \Delta V_{BAT} \leq 0.1V_{BAT}$	1.8	4		$K\Omega$
$R_{IL 5,8}$	Input Resistor LOW Threshold (note 1)	$5V < V_S < 16V$; $ \Delta V_{GND} \leq 0.1V_S$ $ \Delta V_{BAT} \leq 0.1V_{BAT}$	1.8	4.8		$K\Omega$
$R_{IH 1,4}$	Input Resistor HIGH Threshold (note 1)	$5V < V_S < 16V$; $ \Delta V_{GND} \leq 0.1V_S$ $ \Delta V_{BAT} \leq 0.1V_{BAT}$		5.3	20	$K\Omega$
$R_{IH 5,8}$	Input Resistor HIGH Threshold (note 1)	$5V < V_S < 16V$; $ \Delta V_{GND} \leq 0.1V_S$ $ \Delta V_{BAT} \leq 0.1V_{BAT}$		6.5	29	$K\Omega$
R_{IL}	Input Resistor Threshold Ratio (note 1)	$5V < V_S < 16V$; $ \Delta V_{GND} \leq 0.1V_S$ $ \Delta V_{BAT} \leq 0.1V_{BAT}$	0.65	0.75	0.85	
R_{IH}	Input Resistor Threshold Ratio (note 1)	$5V < V_S < 16V$; $ \Delta V_{GND} \leq 0.1V_S$ $ \Delta V_{BAT} \leq 0.1V_{BAT}$	0.65	0.75	0.85	
I_{QC}	Quiescent Current	EN = HIGH ($t_{ENH} \geq 20\mu s$) $V_S = 5$ to $16V$; $T_j = -40$ to $85^\circ C$		20	40	μA
I_{QS}	Quiescent Current	all contact open			10	μA
I_{QS}	Quiescent Current	all contact closed			35	μA
$\Sigma I_{IN} (2)$	Quiescent Current	$ \Delta V_{BAT} \leq 0.1V_{BAT}$			25	μA
I_{QC}	Quiescent Current	EN = LOW			5	mA
I_{QS}	Quiescent Current	EN = LOW			8	mA
t_{do}	Delay Time/Output (EN LOW to Output Data Ready) (note 3)	$C_{OUT} \leq 50pF$			15+ $3R_{IN} * C_{IN}$	μs
t_{dTS}	Delay Time/Tristate (EN HIGH to Output Tristate) (note 3)	$C_{OUT} \leq 50pF$			10	μs
t_{dIO}	Delay Time Input-Output (note 3)	EN = LOW; $C_{OUT} = 50pF$			6	ms

NOTES:

- 1) The input resistor threshold value is a resistor value from the IN-pin to ground at which the corresponding output changes its status (fig.4)
- 2) ΣI_{IN} is the sum of the IN5 to IN8 input currents.
- 3) The delay times are defined from the crossing point of 50% initiating signal amplitude to the crossing point of 50% output signal amplitude

Figure 1: Typical application diagram for the L9705 circuit. The current flowing in the arrow direction is assumed positive. The external capacitors C_{IN} and C_{OUT} represent the total wiring capacitance at the corresponding pins.

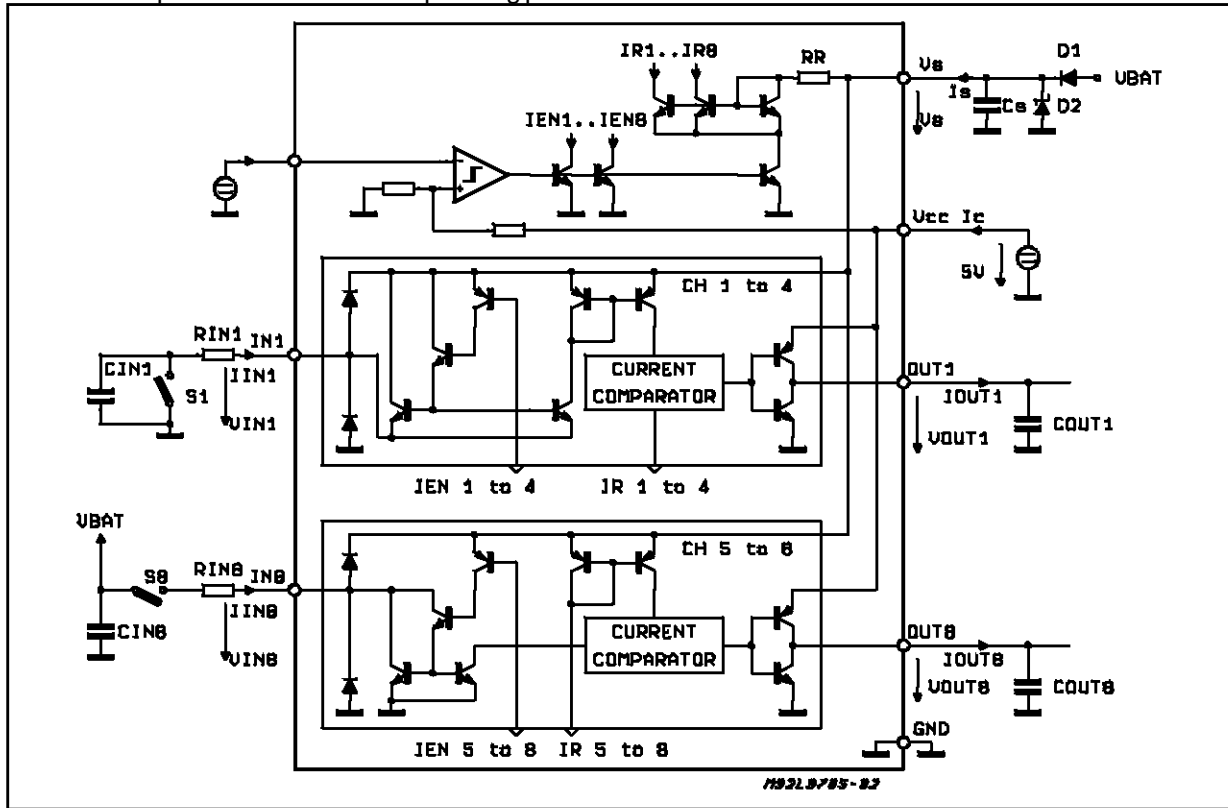

FUNCTIONAL DESCRIPTION

The L9705 circuit monitors the status of the contacts which are connected through the series external resistors R_{IN} to the contact sense input

pins. The contacts equivalent circuit is supposed to be as shown in fig.2 for GND connected contacts (IN 1 to 4) and as shown in fig. 3 for V_{BAT} connected contacts (IN 5 to 8).

Figure 2: The contact sense input connection with the contact equivalent circuit for GND connected contacts.

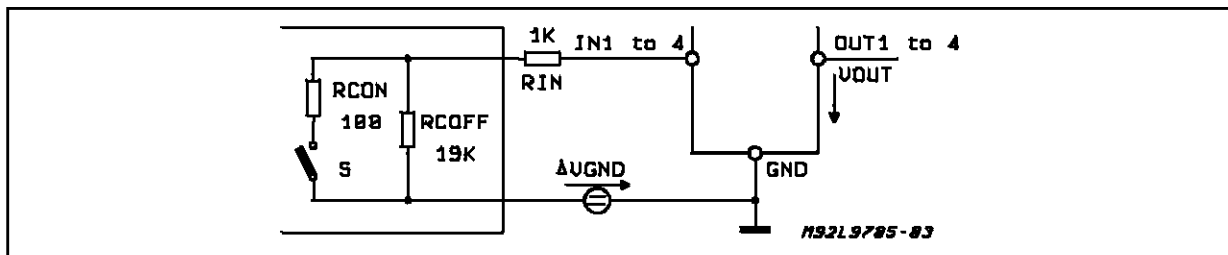
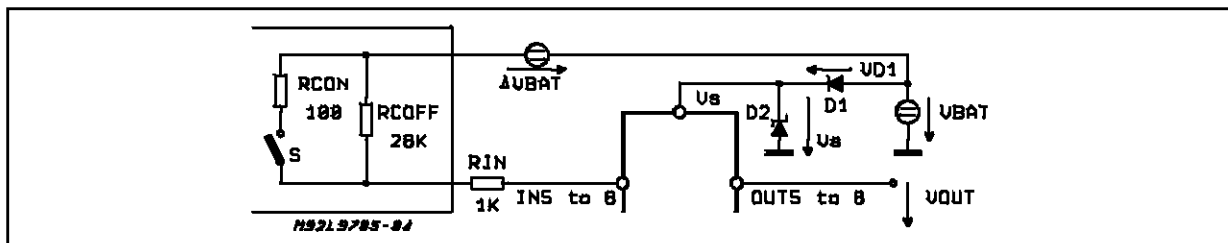

Figure 3: The contact sense input connection with the contact equivalent circuit for V_{BAT} connected contacts.



The L9705 circuit compares the input current with the current through the internal reference resistor. The device is designed to work with an external input series resistor of $R_{IN1-8} = 1K\Omega$. With this input resistor the contact current, when the contact is closed and the device activated (EN =LOW) is:

$$I_{IN} = \frac{V_S - 2V}{1K\Omega}, \text{ for GND contacts, (1)}$$

$$I_{IN} = \frac{V_{BAT} + \Delta V_{BAT} - 2V}{1K\Omega}, \text{ for } V_{BAT} \text{ contacts, (2)}$$

For this calculation the limit value of the V_S to V_{IN} and V_{IN} saturation voltage of 2V was considered so that the lowest limit value of I_{IN} is calculated in (1) and (2)

Figure 4: The output voltage as a function of the input resistance at the corresponding sense input.

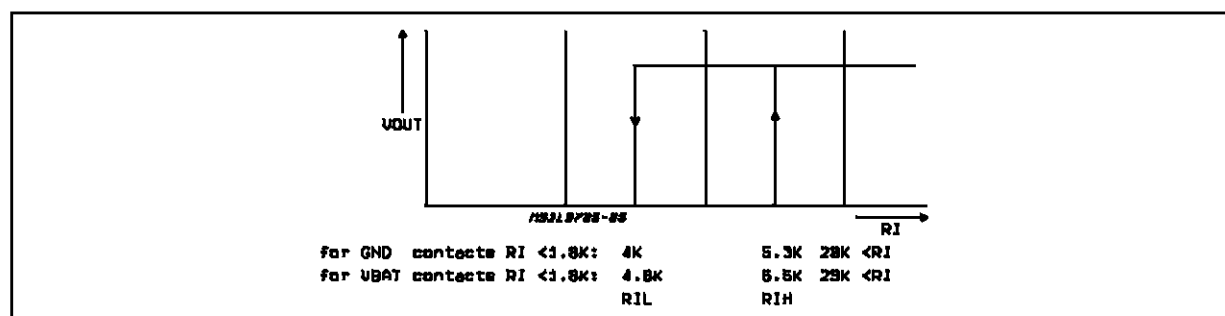

The function of the circuit can be demonstrated with the transfer characteristics, showing the output status as a function of the input resistor R_I , shown in figure 4. The input resistor is a sum of the R_{IN} and the contact resistance R_{CON} or R_{COFF} , for the closed contact:

$$R_I = R_{IN} + R_{CON}, \text{ (3)}$$

and for the open contact:

$$R_I = R_{IN} + R_{COFF}, \text{ (4)}$$

The output goes HIGH when the input resistance increases above $5.3K\Omega$ (GND contacts) or $6.5K\Omega$ (V_{BAT} contacts) and goes LOW, when the input resistance decreases below $4K\Omega$ (GND contacts) or $4.8K\Omega$ (V_{BAT} contacts); these values are typical values for the switching thresholds. The limit values of $R_I = 1.8K\Omega$ (GND contacts) and $R_I = 1.8K\Omega$ (V_{BAT} contacts) for LOW and $R_I = 20K\Omega$ (GND contacts) and $29K\Omega$ (V_{BAT} contacts) for HIGH implies that a contact with $R_{CON} = 100\Omega$ (at $I_{IN} = 10mA$) will be recognized as ON = LOW and a contact with $R_{COFF} = 19K\Omega$ (GND contacts) or $28K\Omega$ (V_{BAT} contact) will be recognized as OFF = HIGH.

These limits are valid within the supply voltage range $6V \leq V_S \leq 16V$, the ground potential difference of $\Delta V_{GND} = 0.1V_S$, the battery voltage potential difference of $\Delta V_{BAT} \leq 0.1V_{BAT}$ and the variation of the reverse battery protection diode $D1$ voltage from 0.5V to 1V.

The internal clamping diodes at the contact monitoring inputs together with the external contacts series resistors R_{IN} allows to withstand the transients at the contact connection. The contact series resistor R_{IN} limits the input current at the transient.

The dynamic behaviour of the circuit is defined with the times t_{do} and t_{dts} . When the contact is open, the input capacitor C_{IN} must be charged through the resistor R_{IN} . In this case the total delay time t_{do} may be influenced also with the time constant $R_{IN}C_{IN}$.

The delay time t_{dts} , when disabling the device, is defined only with the internal circuitry. In both cases, output external capacitance less than 50pF is assumed, the internal output capacitance of the tristate buffers are less than 5pF.

DIP20 PACKAGE MECHANICAL DATA

DIM.	mm			inch		
	MIN.	TYP.	MAX.	MIN.	TYP.	MAX.
a1	0.51			0.020		
B	0.85		1.40	0.033		0.055
b		0.50			0.020	
b1	0.38		0.50	0.015		0.020
D			24.80			0.976
E		8.80			0.346	
e		2.54			0.100	
e3		22.86			0.900	
F			7.10			0.280
I			5.10			0.201
L		3.30			0.130	
Z			1.27			0.050

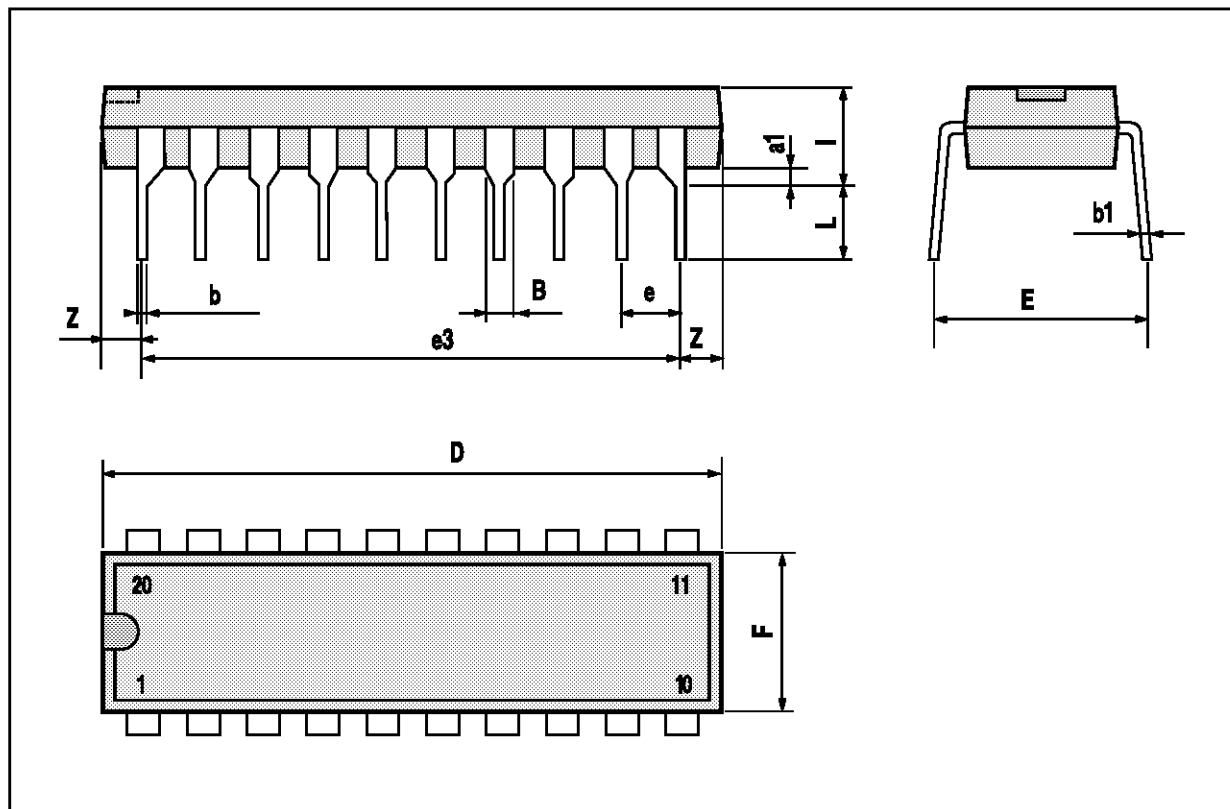

SO20 PACKAGE MECHANICAL DATA

DIM.	mm			inch		
	MIN.	TYP.	MAX.	MIN.	TYP.	MAX.
A			2.65			0.104
a1	0.1		0.3	0.004		0.012
a2			2.45			0.096
b	0.35		0.49	0.014		0.019
b1	0.23		0.32	0.009		0.013
C		0.5			0.020	
c1	45 (typ.)					
D	12.6		13.0	0.496		0.512
E	10		10.65	0.394		0.419
e		1.27			0.050	
e3		11.43			0.450	
F	7.4		7.6	0.291		0.299
L	0.5		1.27	0.020		0.050
M			0.75			0.030
S	8 (max.)					

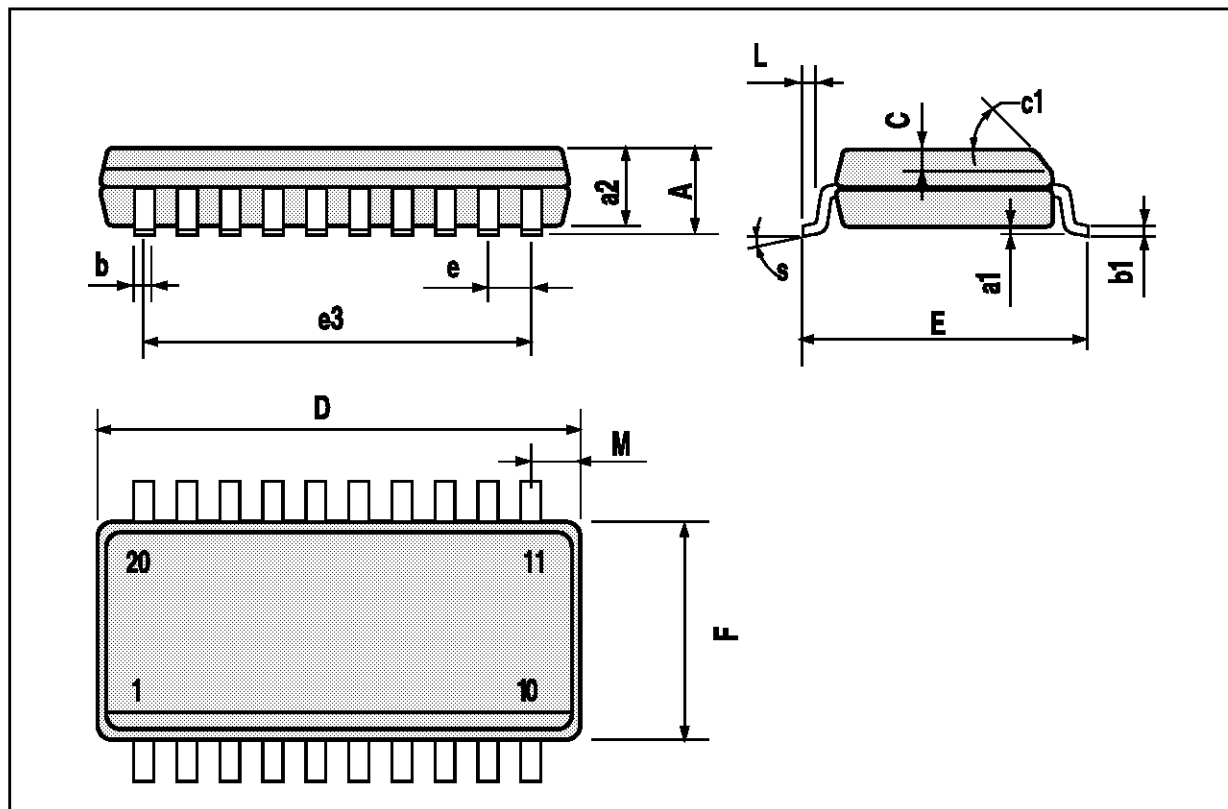

Information furnished is believed to be accurate and reliable. However, SGS-THOMSON Microelectronics assumes no responsibility for the consequences of use of such information nor for any infringement of patents or other rights of third parties which may result from its use. No license is granted by implication or otherwise under any patent or patent rights of SGS-THOMSON Microelectronics. Specifications mentioned in this publication are subject to change without notice. This publication supersedes and replaces all information previously supplied. SGS-THOMSON Microelectronics products are not authorized for use as critical components in life support devices or systems without express written approval of SGS-THOMSON Microelectronics.

© 1994 SGS-THOMSON Microelectronics - All Rights Reserved

SGS-THOMSON Microelectronics GROUP OF COMPANIES

Australia - Brazil - France - Germany - Hong Kong - Italy - Japan - Korea - Malaysia - Malta - Morocco - The Netherlands - Singapore - Spain - Sweden - Switzerland - Taiwan - Thailand - United Kingdom - U.S.A.