

SANYO

No. 4922C

LC72146, 72146M**PLL Frequency Synthesizer
for Electronic Tuning****Overview**

The LC72146 is a PLL frequency synthesizer LSI circuit for electronic tuning in car stereo systems. The LC72146 supports the construction of high-performance, multi-functional electronic tuning systems for the VHF MW, and LW bands.

Features

- High-speed programmable dividers for
 - 10 to 160 MHz on FMIN using pulse swallower
 - 0.5 to 40.0 MHz on AMIN using pulse swallower and direct division
- General-purpose counters
 - HCTR for 0.4 to 25.0 MHz frequency measurement
 - LCTR for 10 to 500 kHz frequency measurement and 1.0 Hz to 20×10^3 kHz period measurement
- Reference frequencies: Twelve selectable reference frequencies (4.5 or 7.2 MHz crystal) 1, 3, 5, 9, 10, 3.125, 6.25, 12.5, 25, 30, 50 and 100 kHz
- Phase comparator
 - Insensitive band control
 - Unlock detection
 - Sub-charge pump for high-speed locking
 - Deadlock clear circuit
- CCB input/output data interface
- Power-on reset circuit
- Built-in MOS transistor for a low-pass filter
- Inputs/outputs (using five general-purpose input/output ports)
 - Maximum of seven inputs (max)
 - Maximum of seven outputs (max/four n-channel open-drain and three CMOS outputs)
 - Time-base output for clock (8 Hz)
- Operating ranges
 - Supply voltage4.5 to 5.5 V
 - Operating temperature-40 to 85°C
- Package
 - DIP24S, MFP24S

- CCB is a trademark of SANYO ELECTRIC CO., LTD.
- CCB is SANYO's original bus format and all the bus addresses are controlled by SANYO.

Package Dimensions

unit: mm

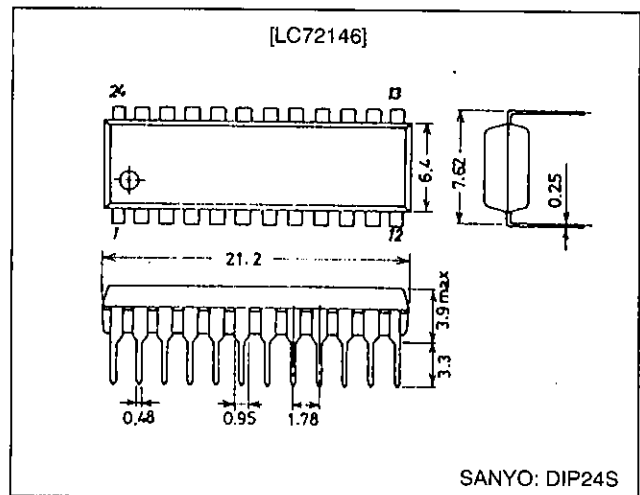
3067-DIP24S

unit: mm

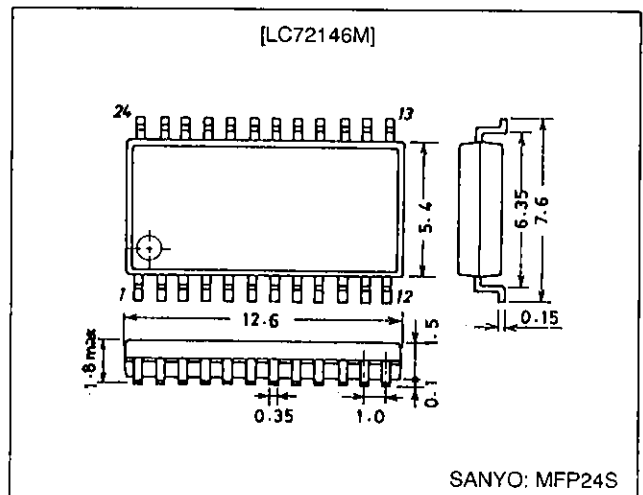
3112-MFP24S**SANYO Electric Co., Ltd. Semiconductor Business Headquarters**

TOKYO OFFICE Tokyo Bldg., 1-10, 1 Chome, Ueno, Taito-ku, TOKYO, 110 JAPAN

Specifications

Absolute Maximum Ratings at Ta = 25°C, VSS = 0 V

Parameter	Symbol	Conditions	Ratings	Unit
Maximum supply voltage	V _{DD} max	V _{DD}	-0.3 to +7.0	V
Maximum input voltage	V _{IN1} max	CE, CL, DI	-0.3 to +7.0	V
	V _{IN2} max	XIN, FMIN, AIN, AMIN, HCTR/I-6, LCTR/I-7, I/O-4, I/O-5	-0.3 to V _{DD} + 0.3	V
	V _{IN3} max	I/O-1 to I/O-3	-0.3 to +15	V
Maximum output voltage	V _{O1} max	DO	-0.3 to +7.0	V
	V _{O2} max	XOUT, I/O-4, I/O-5, O-6, PD0, PF1, AIN	-0.3 to V _{DD} + 0.3	V
	V _{O3} max	I/O-1 to I/O-3, AOUT, O-7	-0.3 to +15	V
Maximum output current	I _{O1} max	I/O-4, I/O-5, O-6, O-7	0 to 3.0	mA
	I _{O2} max	DO, AOUT	0 to 6.0	mA
	I _{O3} max	I/O-1 to I/O-3	0 to 10	mA
Allowable power dissipation	Pd max	DIP24S: Ta ≤ 85°C	350	mW
		MFP24S: Ta ≤ 85°C	220	mW
Operating temperature	T _{opr}		-40 to +85	°C
Storage temperature	T _{stg}		-55 to +125	°C

Allowable Operating Ranges at Ta = -40 to 85°C, VSS = 0 V

Parameter	Symbol	Conditions	min	typ	max	Unit
Supply voltage	V _{DD1}	V _{DD}	4.5		5.5	V
	V _{DD2}	V _{DD} : Serial data retain voltage	2.0			V
Input high-level voltage	V _{IH1}	CE, CL, DI, I/O-1 to I/O-3	2.2		6.5	V
	V _{IH2}	I/O-4, I/O-5, HCTR/I-6 and LCTR/I-7	2.2		V _{DD}	V
Input low-level voltage	V _{IL1}	CE, CL, DI and I/O-1 to I/O-5, HCTR/I-6, LCTR/I-7	0		0.8	V
Input high-level voltage	V _{IH3}	LCTR/I-7, Pulse wave*1	2.2		V _{DD}	V
Input low-level voltage	V _{IL2}	LCTR/I-7, Pulse wave*1	0		0.8	V
Output voltage	V _{O1}	DO	0		6.5	V
	V _{O2}	I/O-1 to I/O-3, AOUT, O-7	0		13	V
Input frequency	f _{IN1}	XIN; Sine wave, capacitive coupling	1.0		8.0	MHz
	f _{IN2}	FMIN; Sine wave, capacitive coupling	10		160	MHz
	f _{IN3}	AMIN; Sine wave, capacitive coupling	0.5		40	MHz
	f _{IN4}	HCTR/I-6; Sine wave, capacitive coupling	0.4		25	MHz
	f _{IN5}	LCTR/I-7; Sine wave, capacitive coupling	10		500	kHz
	f _{IN6}	LCTR/I-7; Pulse wave, DC coupling*1	1.0		20 × 10 ³	Hz
Guaranteed oscillator element frequencies	Xtal	XIN, XOUT; CI ≤ 120 Ω	4.0		8.0	MHz
Input amplitude	V _{IN1}	XIN	200		1500	mVrms
	V _{IN2-1}	FMIN; 50 ≤ f < 130 MHz*2	40		1500	mVrms
	V _{IN2-2}	FMIN; 10 ≤ f < 50 MHz*2, 130 ≤ f < 160 MHz	70		1500	mVrms
	V _{IN3-1}	AMIN; 2 ≤ f < 25 MHz*2	40		1500	mVrms
	V _{IN3-2}	AMIN; 25 ≤ f < 40 MHz*2	70		1500	mVrms
	V _{IN3-3}	AMIN; 0.5 ≤ f < 2.5 MHz*2	40		1500	mVrms
	V _{IN3-4}	AMIN; 2.5 ≤ f < 10 MHz*2	70		1500	mVrms
	V _{IN4-1}	HCTR/I-6; 0.4 ≤ f < 25 MHz*3	40		1500	mVrms
	V _{IN4-2}	HCTR/I-6; 8 ≤ f < 12 MHz*4	70		1500	mVrms
	V _{IN5-1}	LCTR/I-7; 10 ≤ f < 400 kHz*3	40		1500	mVrms
	V _{IN5-2}	LCTR/I-7; 400 ≤ f < 500 kHz*3	20		1500	mVrms
	V _{IN5-3}	LCTR/I-7; 400 ≤ f < 500 kHz*4	70		1500	mVrms
	Data set up time	t _{SU}	DI, CL*5	0.45		
Data hold time	t _{HD}	DI, CL*5	0.45			μs

Continued on next page.

LC72146, 72146M

Continued from preceding page.

Parameter	Symbol	Conditions	min	typ	max	Unit
Clock low-level time	t_{CL}	CL*5	0.45			μs
Clock high-level time	t_{CH}	CL*5	0.45			μs
CE wait time	t_{EL}	CE, CL*5	0.45			μs
CE setup time	t_{ES}	CL, CE*5	0.45			μs
CE hold time	t_{EH}	CE, CL*5	0.45			μs
Chip enable to data latch time	t_{LC}	*5			0.45	μs
Data output time	t_{DC}	DO, CL; Depends on pull-up resistor			0.2	μs

- Note: 1. Period measurement
 2. See the description of the structure of the programmable divider.
 3. With the CTC bit in the serial data set to 0
 4. With the CTC bit in the serial data set to 1
 5. See the description of the serial data timing.

Electrical Characteristics at $T_a = -40$ to $+85^\circ C$, $V_{SS} = 0$ V

Parameter	Symbol	Conditions	min	typ	max	Unit
Internal feedback resistance	Rf1	XIN		1.0		$m\Omega$
	Rf2	FMIN		500		$k\Omega$
	Rf3	AMIN		500		$k\Omega$
	Rf4	HCTR/I-6		250		$k\Omega$
	Rf5	LCTR/I-7		250		$k\Omega$
Sub charge pump internal resistance	R1S	AIN		100		Ω
Hysteresis	V_{HIS}	CE, CL, DI, LCTR/I-7		$0.1 V_{DD}$		V
Output high-level voltage	V_{OH1}	PD0, PD1, I/O-4, I/O-5, O-6	$I_O = 0.5$ mA	$V_{DD} - 0.5$		V
			$I_O = 1$ mA	$V_{DD} - 1.0$		V
			$I_O = 2$ mA	$V_{DD} - 2.0$		V
V_{OH2}	AIN; $I_O = 1$ mA	$V_{DD} - 0.6$	$V_{DD} - 0.3$		V	
Output low-level voltage	V_{OL1}	PD0, PD1, I/O-4, I/O-5, O-6, O-7	$I_O = 0.5$ mA		0.5	V
			$I_O = 1$ mA		1.0	V
			$I_O = 2$ mA		2.0	V
	V_{OL2}	AIN; $I_O = 1$ mA		0.3	0.6	V
	V_{OL3}	I/O-1 to I/O-3	$I_O = 1$ mA		0.2	V
			$I_O = 2.5$ mA		0.5	V
			$I_O = 5$ mA		1.0	V
V_{OL4}	DO; $I_O = 5$ mA			1.0	V	
V_{OL5}	AOUT; $I_O = 1$ mA, AIN = 1.3 V			0.5	V	
Input high-level current	I_{IH1}	CE, CL, DI; $V_I = 6.5$ V			5.0	μA
	I_{IH2}	I/O-1 to I/O-3; $V_I = 13$ V			5.0	μA
	I_{IH3}	I/O-4, I/O-5, HCTR/I-6, LCTR/I-7; $V_I = V_{DD}$			5.0	μA
	I_{IH4}	XIN; $V_I = V_{DD}$	2.0		11	μA
	I_{IH5}	FMIN, AMIN; $V_I = V_{DD}$	4.0		22	μA
	I_{IH6}	HCTR/I-6, LCTR/I-7; $V_I = V_{DD}$	8.0		44	μA
Input low-level current	I_{IL1}	CE, CL, DI; $V_I = 0$ V			5.0	μA
	I_{IL2}	I/O-1 to I/O-5; $V_I = 0$ V			5.0	μA
	I_{IL3}	HCTR/I-6, LCTR/I-7; $V_I = 0$ V			5.0	μA
	I_{IL4}	XIN; $V_I = 0$ V	2.0		11	μA
	I_{IL5}	FMIN, AMIN; $V_I = 0$ V	4.0		22	μA
	I_{IL6}	HCTR/I-6, LCTR/I-7; $V_I = 0$ V	8.0		44	μA

Continued on next page.

LC72146, 72146M

Continued from preceding page.

Parameter	Symbol	Conditions	min	typ	max	Unit
Output off leakage current	I_{OFF1}	I/O-1 to I/O3, AOUT, O-7; $V_O = 13\text{ V}$			5.0	μA
	I_{OFF2}	DO; $V_O = 6.5\text{ V}$			5.0	μA
High-level three state off leakage current	I_{OFFH}	PD0, PD1, AIN; $V_O = V_{DD}$		0.01	200	nA
Low-level three state off leakage current	I_{OFFL}	PD0, PD1, AIN; $V_O = 0\text{ V}$		0.01	200	nA
Input capacitance	C_{IN}	FMIN		6		pF
Pull-down transistor on resistance	R_{pd1}	FMIN	80	200	600	k Ω
	R_{pd2}	AMIN	80	200	600	k Ω
Supply current	I_{DD1}	V_{DD} : Xtal = 7.2 MHz, $f_{IN2} = 160\text{ MHz}$, $V_{IN2} = 70\text{ mVrms}$, $f_{IN4} = 25\text{ MHz}$		10	15	mA
		$V_{IN4} = 40\text{ mVrms}$				
		V_{DD} : PLL inhibited, crystal oscillator running (Xtal = 7.2 MHz)		0.5	1.5	mA
	I_{DD3}	V_{DD} : PLL inhibited, crystal oscillator stopped			10	μA

Pin Assignment

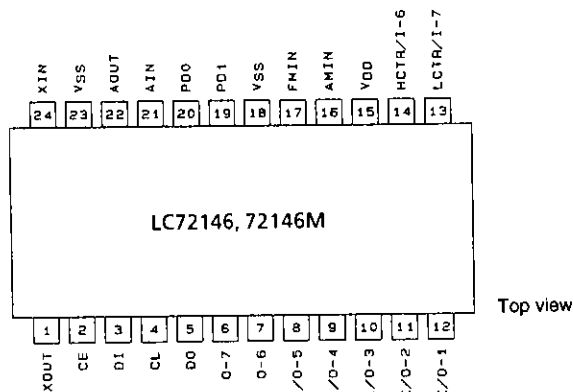

A02675

Block Diagram

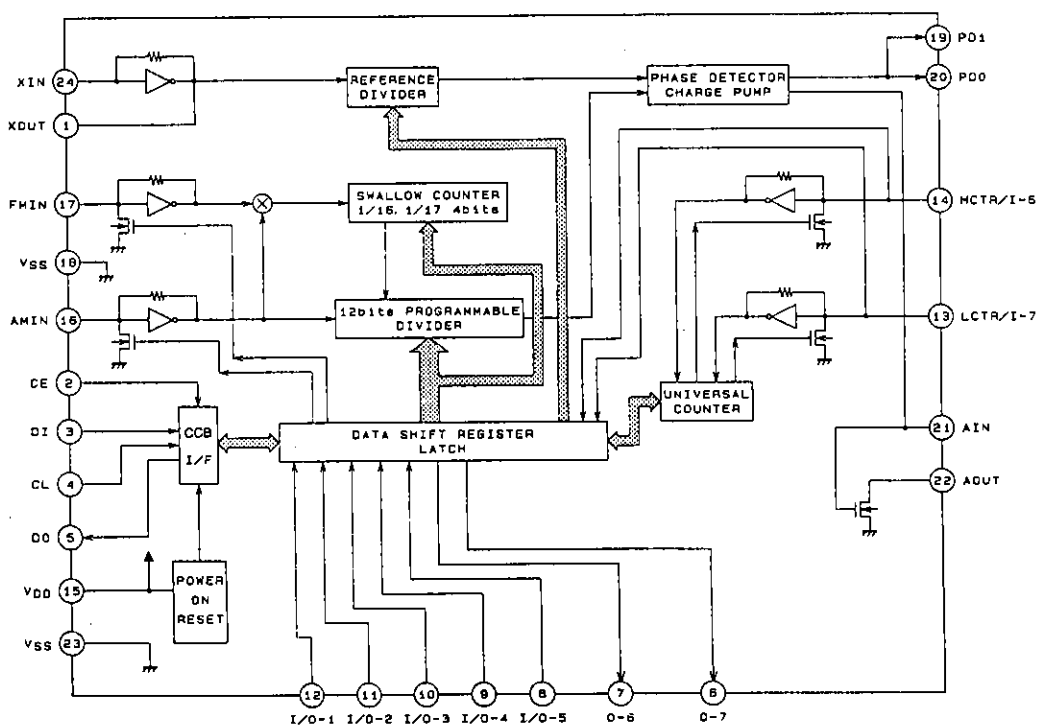

A03690

LC72146, 72146M

Pin Functions

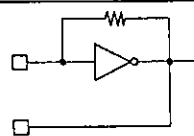
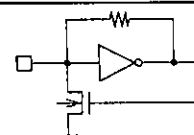
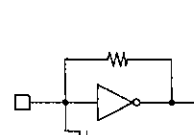
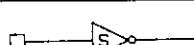
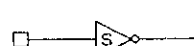
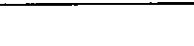
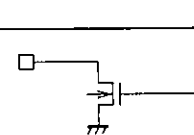
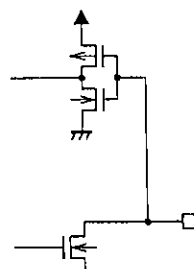
Number	Symbol	Type	Function	Equivalent circuit
24 1	XIN XOUT	Xtal OSC	Connection for crystal oscillator element (7.2 or 4.5 MHz)	 A02677
17	FMIN	Local oscillator signal input	<ul style="list-style-type: none"> Serial data input: FMIN is selected when DVS is set to 1. Input frequency range: 10 to 160 MHz The signal is transmitted directly to the swallow counter Divisor value range: 272 to 65535 	 A02678
16	AMIN	Local oscillator signal input	<ul style="list-style-type: none"> Serial data input: AMIN is selected when DVS is set to 0. Serial data Input: when SNS is set to 1. Input frequency range: 2 to 40 MHz The signal is transmitted directly to the swallow counter. Divisor value range: 272 to 65535 Serial data Input: when SNS is set to 0. Input frequency range: 0.5 to 10 MHz The signal is transmitted directly to the 12-bit programmable divider. Divisor value range: 4 to 4095 	 A02678
2	CE	Chip enable	<ul style="list-style-type: none"> This pin must be set high to input serial data to the LC72146 DI pin or to output serial data from the DO pin. 	 A02679
4	CL	Clock	<ul style="list-style-type: none"> Inputs the clock used for data synchronization when inputting serial data to the LC72146 DI pin or outputting serial data from the DO pin. 	 A02679
3	DI	Input data	<ul style="list-style-type: none"> Input pin for serial data transmitted to the LC72146 from a controller. 	 A02679
5	DO	Output data	<ul style="list-style-type: none"> Output pin for serial data transmitted from the LC72146 to a controller. 	 A02680
15	V _{DD}	Power supply	<ul style="list-style-type: none"> The LC72146 power supply connection. A voltage between 4.5 and 5.5 volts must be supplied when the PLL circuit is used. The power on reset circuit operates when power is first applied. 	
18 23	V _{DD}	Ground	<ul style="list-style-type: none"> The LC72146 ground connection. 	
12 11 10	I/O-1 I/O-2 I/O-3	General-purpose I/O port	<ul style="list-style-type: none"> General-purpose I/O ports Output mode circuit type: open drain Function after a power on reset: Input port Can be set up to function as output ports by bits I/O-1 to I/O-3 in the serial data sent from the controller. 	 A02681

Continued on next page.

LC72146, 72146M

Continued from preceding page.

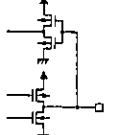
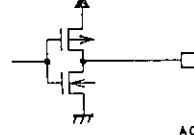
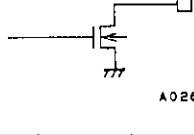
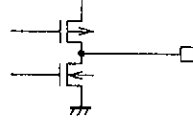
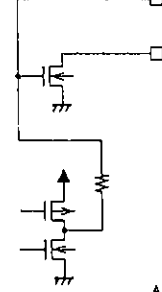
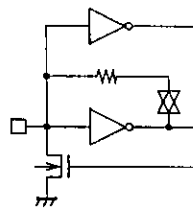
Number	Symbol	Type	Function	Equivalent circuit
9 8	I/O-4 I/O-5	General-purpose I/O port	<ul style="list-style-type: none"> General-purpose I/O ports Output mode circuit type: complementary Function after a power on reset: input port Can be set up to function as output ports by bits I/O-4 and I/O-5 in the serial data sent from the controller. 	 <p>A02682</p>
7	O-6	Output port	<ul style="list-style-type: none"> The LC72146 latches the OUT6 bit in the serial data and outputs it from pin O-6. 	 <p>A02683</p>
6	O-7	Output port	<ul style="list-style-type: none"> The LC72146 latches the OUT7 bit in the serial data and outputs it from pin O-7. Outputs a time base signal (8 Hz) when TBC is set to 1. Function after a power on reset: open circuit 	 <p>A02684</p>
20 19	PD0 PD1	Charge pump output	<ul style="list-style-type: none"> PLL charge pump output pin If the frequency generated by dividing the local oscillator frequency by N is higher than the reference frequency, a high level will be output from PD0, and if it is lower, a low level will be output. PD0 goes to the high-impedance state when the frequencies match. PD1 operates identically. 	 <p>A02685</p>
21 22	AIN AOUT	Connections for the low-pass filter transistor	<ul style="list-style-type: none"> Connections to the n-channel MOS transistor used for the PLL active low-pass filter. A high-speed locking circuit can be formed by using these pins with the built-in sub charge pump. See the item on the structure of the charge pump for details. 	 <p>A02686</p>
14	HCTR/I-6	General-purpose counter	<ul style="list-style-type: none"> HCTR is selected when CTS1 is set to 1. Input frequency range: 0.4 to 25 MHz The signal is passed through a divide-by-two circuit and then input to a general-purpose counter. This input also supports an integrating count function. The result is output from the DO output pin starting with the MSB of the general-purpose counter. See the item on the structure of the general-purpose counter for details. When the H/I-6 bit in the serial data is set to 0: This pin functions as an input port, and the value input is output from the DO pin. 	 <p>A02687</p>

Continued on next page.

LC72146, 72146M

Continued from preceding page.

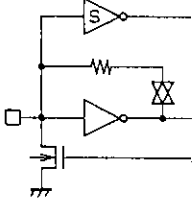
Number	Symbol	Type	Function	Equivalent circuit
13	LCTR/L-7	General-purpose counter	<ul style="list-style-type: none"> • LCTR is selected when CTS1 is set to 0. • If the CTS0 bit in the serial data is set to 1: • The circuit operates in frequency measurement mode. • Input frequency range: 10 to 500 kHz • The signal is directly transmitted to the general-purpose counter without passing through the divide-by-two circuit. • If the CTS0 bit in the serial data is set to 0: • The circuit operates in period measurement mode. • Input frequency range: 1 Hz to 20 kHz • The measurement period can be set to be either one or two periods of the input signal, and if two period measurement is selected, the input frequency range becomes 2 Hz to 40 kHz. • The result is output from the DO output pin starting with the MSB of the general-purpose counter. • See the item on the structure of the general-purpose counter for details. • When the L/L-7 bit in the serial data is set to 0: • This pin functions as an input port. The value input is output from the DO pin. 	 <p style="text-align: right;">A02666</p>

Functional Description

Serial Data Input

The LC72146/72146M operating parameters are initialized by two 40-bit data words on the serial data input, DI, as shown in Figure 1 and Figure 2 and Table 1.

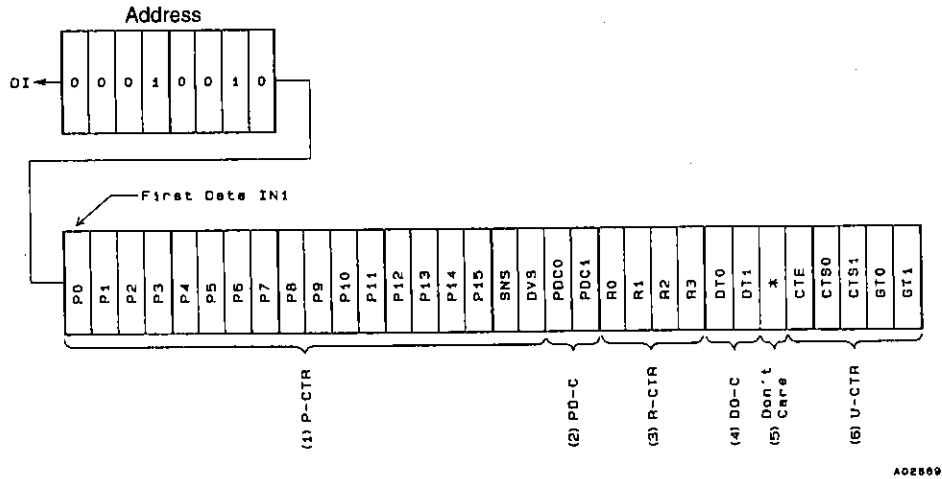

Figure 1 Input Data Word IN1

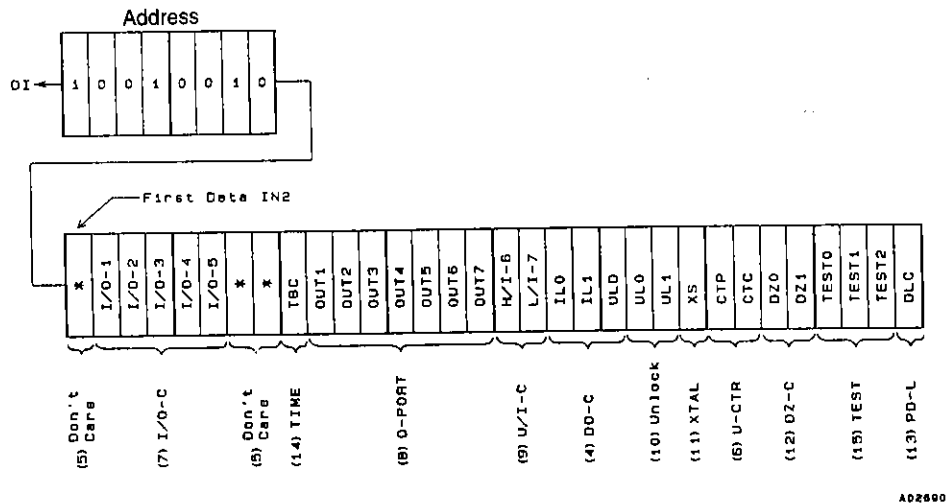

Figure 2 Input Data Word IN2

Table 1 Input Data Functions

No.	Name	Function	Related bits																																																																																					
(1)	P0 to P15, DVS, SNS	<p>Programmable divider ratio P15 is the MSB. The divider ratio, frequency range and lsb are determined by the setting of the DVS and SNS flags as shown in Table 2 and Table 3. P0 to P3 are ignored if P4 is the LSB.</p> <p>Table 2 Divider ratio settings</p> <table border="1"> <thead> <tr> <th>DVS</th> <th>SNS</th> <th>LSB</th> <th>Divider ratio (N)</th> </tr> </thead> <tbody> <tr> <td>1</td> <td>x</td> <td>P0</td> <td>272 to 65535</td> </tr> <tr> <td>0</td> <td>1</td> <td>P0</td> <td>272 to 65535</td> </tr> <tr> <td>0</td> <td>0</td> <td>P4</td> <td>4 to 4095</td> </tr> </tbody> </table> <p>Note: x = don't care</p> <p>Table 3 Frequency range settings</p> <table border="1"> <thead> <tr> <th>DVS</th> <th>SNS</th> <th>Input port</th> <th>Input frequency range (MHz)</th> </tr> </thead> <tbody> <tr> <td>1</td> <td>x</td> <td>FMIN</td> <td>10 to 160</td> </tr> <tr> <td>0</td> <td>1</td> <td>AMIN</td> <td>2 to 40</td> </tr> <tr> <td>0</td> <td>0</td> <td>AMIN</td> <td>0.5 to 10</td> </tr> </tbody> </table> <p>Note: x = don't care</p>	DVS	SNS	LSB	Divider ratio (N)	1	x	P0	272 to 65535	0	1	P0	272 to 65535	0	0	P4	4 to 4095	DVS	SNS	Input port	Input frequency range (MHz)	1	x	FMIN	10 to 160	0	1	AMIN	2 to 40	0	0	AMIN	0.5 to 10																																																						
DVS	SNS	LSB	Divider ratio (N)																																																																																					
1	x	P0	272 to 65535																																																																																					
0	1	P0	272 to 65535																																																																																					
0	0	P4	4 to 4095																																																																																					
DVS	SNS	Input port	Input frequency range (MHz)																																																																																					
1	x	FMIN	10 to 160																																																																																					
0	1	AMIN	2 to 40																																																																																					
0	0	AMIN	0.5 to 10																																																																																					
(2)	PDC0, PDC1	<p>Sub-charge pump control Bits PDC0 and PDC1 control the charge pump state as shown in Table 4. The sub-charge pump is connected to the gate of the low-pass filter transistor. This can be used in conjunction with PD0 and PD1 (main charge pump) to build a fast locking PLL.</p> <p>Table 4 Charge pump state selection</p> <table border="1"> <thead> <tr> <th>PDC0</th> <th>PDC1</th> <th>Charge pump state</th> </tr> </thead> <tbody> <tr> <td>0</td> <td>x</td> <td>High impedance</td> </tr> <tr> <td>1</td> <td>1</td> <td>Operating (operates continuously)</td> </tr> <tr> <td>1</td> <td>0</td> <td>Operating (when PLL is unlocked)</td> </tr> </tbody> </table> <p>Note: x = don't care * See the "Charge Pump" on page 16 for details.</p>	PDC0	PDC1	Charge pump state	0	x	High impedance	1	1	Operating (operates continuously)	1	0	Operating (when PLL is unlocked)	UL0, UL1, DLC																																																																									
PDC0	PDC1	Charge pump state																																																																																						
0	x	High impedance																																																																																						
1	1	Operating (operates continuously)																																																																																						
1	0	Operating (when PLL is unlocked)																																																																																						
(3)	R0 to R3	<p>Reference frequency select Bits R0 to R3 disable the PLL or select the reference frequency as shown in Table 5.</p> <p>Table 5 Reference frequency selection</p> <table border="1"> <thead> <tr> <th>R₃</th> <th>R₂</th> <th>R₁</th> <th>R₀</th> <th>Reference frequency (kHz)</th> </tr> </thead> <tbody> <tr><td>0</td><td>0</td><td>0</td><td>0</td><td>100</td></tr> <tr><td>0</td><td>0</td><td>0</td><td>1</td><td>50</td></tr> <tr><td>0</td><td>0</td><td>1</td><td>0</td><td>25</td></tr> <tr><td>0</td><td>0</td><td>1</td><td>1</td><td>25</td></tr> <tr><td>0</td><td>1</td><td>0</td><td>0</td><td>12.5</td></tr> <tr><td>0</td><td>1</td><td>0</td><td>1</td><td>6.25</td></tr> <tr><td>0</td><td>1</td><td>1</td><td>0</td><td>3.125</td></tr> <tr><td>0</td><td>1</td><td>1</td><td>1</td><td>3.125</td></tr> <tr><td>1</td><td>0</td><td>0</td><td>0</td><td>10</td></tr> <tr><td>1</td><td>0</td><td>0</td><td>1</td><td>9</td></tr> <tr><td>1</td><td>0</td><td>1</td><td>0</td><td>5</td></tr> <tr><td>1</td><td>0</td><td>1</td><td>1</td><td>1</td></tr> <tr><td>1</td><td>1</td><td>0</td><td>0</td><td>3</td></tr> <tr><td>1</td><td>1</td><td>0</td><td>1</td><td>30</td></tr> <tr><td>1</td><td>1</td><td>1</td><td>0</td><td>PLL inhibited and crystal oscillator stopped</td></tr> <tr><td>1</td><td>1</td><td>1</td><td>1</td><td>PLL inhibited</td></tr> </tbody> </table> <p>When the PLL is disabled, the programmable divider is stopped, AMIN and FMIN are pulled to ground, and the charge-pump outputs become high impedance.</p>	R ₃	R ₂	R ₁	R ₀	Reference frequency (kHz)	0	0	0	0	100	0	0	0	1	50	0	0	1	0	25	0	0	1	1	25	0	1	0	0	12.5	0	1	0	1	6.25	0	1	1	0	3.125	0	1	1	1	3.125	1	0	0	0	10	1	0	0	1	9	1	0	1	0	5	1	0	1	1	1	1	1	0	0	3	1	1	0	1	30	1	1	1	0	PLL inhibited and crystal oscillator stopped	1	1	1	1	PLL inhibited	
R ₃	R ₂	R ₁	R ₀	Reference frequency (kHz)																																																																																				
0	0	0	0	100																																																																																				
0	0	0	1	50																																																																																				
0	0	1	0	25																																																																																				
0	0	1	1	25																																																																																				
0	1	0	0	12.5																																																																																				
0	1	0	1	6.25																																																																																				
0	1	1	0	3.125																																																																																				
0	1	1	1	3.125																																																																																				
1	0	0	0	10																																																																																				
1	0	0	1	9																																																																																				
1	0	1	0	5																																																																																				
1	0	1	1	1																																																																																				
1	1	0	0	3																																																																																				
1	1	0	1	30																																																																																				
1	1	1	0	PLL inhibited and crystal oscillator stopped																																																																																				
1	1	1	1	PLL inhibited																																																																																				

Continued on next page.

Continued from preceding page.

No.	Name	Function	Related bits																																																						
(4)	ULD, DT0, DT1, IL0, IL1	<p>DO and I/O5 output control data Bits ULD, DT0, DT1, IL0 and IL1 control the mode of outputs DO and I/O5 as shown in Table 6 and Table 7.</p> <p>Table 6 DO and I/O5 output flag selection</p> <table border="1"> <thead> <tr> <th>ULD</th> <th>DT1</th> <th>DT0</th> <th>DO</th> <th>I/O5</th> </tr> </thead> <tbody> <tr> <td>0</td> <td>0</td> <td>0</td> <td>Unlock flag</td> <td rowspan="4">OUT5 flag*2.</td> </tr> <tr> <td>0</td> <td>0</td> <td>1</td> <td>Open</td> </tr> <tr> <td>0</td> <td>1</td> <td>0</td> <td>End-UC flag*1.</td> </tr> <tr> <td>0</td> <td>1</td> <td>1</td> <td>IN. See table 7.</td> </tr> <tr> <td>1</td> <td>0</td> <td>0</td> <td>Open</td> <td rowspan="4">Unlock flag*2.</td> </tr> <tr> <td>1</td> <td>0</td> <td>1</td> <td>Open</td> </tr> <tr> <td>1</td> <td>1</td> <td>0</td> <td>End-UC flag</td> </tr> <tr> <td>1</td> <td>1</td> <td>1</td> <td>IN. See table 7.</td> </tr> </tbody> </table> <p>Note: *1. End-UC flags that general-purpose counter operation has finished. *2. Applicable only if I/O5 is set to be an output port.</p> <p>Figure 3 DO output state</p> <p>Table 7 IN state selection</p> <table border="1"> <thead> <tr> <th>IL1</th> <th>IL0</th> <th>IN state</th> </tr> </thead> <tbody> <tr> <td>0</td> <td>0</td> <td>Open</td> </tr> <tr> <td>0</td> <td>1</td> <td>I1 input</td> </tr> <tr> <td>1</td> <td>0</td> <td>I2 input</td> </tr> <tr> <td>1</td> <td>1</td> <td>DO goes low when I1 changes.</td> </tr> </tbody> </table> <p>Note: 1. If I/O1 or I/O2 is set to be an output port, IN becomes open. 2. DO does not go low when the crystal oscillator has stopped. [When reference frequencies are as these: R3 = R2 = R1 = 1; R0 = 0]</p>	ULD	DT1	DT0	DO	I/O5	0	0	0	Unlock flag	OUT5 flag*2.	0	0	1	Open	0	1	0	End-UC flag*1.	0	1	1	IN. See table 7.	1	0	0	Open	Unlock flag*2.	1	0	1	Open	1	1	0	End-UC flag	1	1	1	IN. See table 7.	IL1	IL0	IN state	0	0	Open	0	1	I1 input	1	0	I2 input	1	1	DO goes low when I1 changes.	OUT5, I/O1, I/O2, I/O5
ULD	DT1	DT0	DO	I/O5																																																					
0	0	0	Unlock flag	OUT5 flag*2.																																																					
0	0	1	Open																																																						
0	1	0	End-UC flag*1.																																																						
0	1	1	IN. See table 7.																																																						
1	0	0	Open	Unlock flag*2.																																																					
1	0	1	Open																																																						
1	1	0	End-UC flag																																																						
1	1	1	IN. See table 7.																																																						
IL1	IL0	IN state																																																							
0	0	Open																																																							
0	1	I1 input																																																							
1	0	I2 input																																																							
1	1	DO goes low when I1 changes.																																																							
(5)	*	Don't care.																																																							
(6)	CTS0, CTS1, CTE, GT0, GT1 CTP, CTC	<p>Counter control Bits CTS0 and CTS1 select the counter input as shown in Table 8.</p> <p>Table 8 Counter Input and measurement mode selection</p> <table border="1"> <thead> <tr> <th>CTS1</th> <th>CTS0</th> <th>Input</th> <th>Measurement mode</th> </tr> </thead> <tbody> <tr> <td>1</td> <td>x</td> <td>HCTR</td> <td>Frequency</td> </tr> <tr> <td>0</td> <td>1</td> <td>LCTR</td> <td>Frequency</td> </tr> <tr> <td>0</td> <td>0</td> <td>LCTR</td> <td>Period</td> </tr> </tbody> </table> <p>Note: x = don't care</p> <p>Bit CTE starts the counter when 1, and resets the counter, when 0. Bits GT0 and GT1 select the measurement time in frequency measurement mode or the number of periods to count in period measurement mode as shown in Table 9.</p> <p>Table 9 Measurement duration selection</p> <table border="1"> <thead> <tr> <th rowspan="2">GT1</th> <th rowspan="2">GT0</th> <th colspan="2">Frequency measurement</th> <th>Period measurement</th> </tr> <tr> <th>Measurement duration (ms)</th> <th>Wait time (ms)</th> <th>Cycles</th> </tr> </thead> <tbody> <tr> <td>0</td> <td>0</td> <td>4</td> <td rowspan="2">3 to 4</td> <td rowspan="2">1</td> </tr> <tr> <td>0</td> <td>1</td> <td>8</td> </tr> <tr> <td>1</td> <td>0</td> <td>32</td> <td rowspan="2">7 to 8</td> <td rowspan="2">2</td> </tr> <tr> <td>1</td> <td>1</td> <td>64</td> </tr> </tbody> </table> <p>When CTE is 0 the input is pulled down, and when CTP is 1 it is not. (Wait time: 1 to 2 ms.) CTP must be set to 1 at least 4 ms before CTE is set to 1. The input sensitivity can be reduced by setting CTC to 1. (Sensitivity: 10 to 30 mV rms)</p>	CTS1	CTS0	Input	Measurement mode	1	x	HCTR	Frequency	0	1	LCTR	Frequency	0	0	LCTR	Period	GT1	GT0	Frequency measurement		Period measurement	Measurement duration (ms)	Wait time (ms)	Cycles	0	0	4	3 to 4	1	0	1	8	1	0	32	7 to 8	2	1	1	64	H/I6, L/I7														
CTS1	CTS0	Input	Measurement mode																																																						
1	x	HCTR	Frequency																																																						
0	1	LCTR	Frequency																																																						
0	0	LCTR	Period																																																						
GT1	GT0	Frequency measurement		Period measurement																																																					
		Measurement duration (ms)	Wait time (ms)	Cycles																																																					
0	0	4	3 to 4	1																																																					
0	1	8																																																							
1	0	32	7 to 8	2																																																					
1	1	64																																																							

Continued on next page.

Continued from preceding page.

No.	Name	Function	Related bits																				
(7)	I/O1 to I/O5	Input/output port control Bits I/O1 to I/O5 set the direction of the ports. Each pin is an input when the corresponding bit is 0, and an output, when the bit is 1. All ports are set to be inputs after power-on reset.	OUT1 to OUT5, ULD																				
(8)	OUT1 to OUT7	Output port data Bits OUT1 to OUT7 set the output values of the O-1 to O-7 output ports. Each output is open or high when the corresponding bit is 1, and low, when the bit is 0. A bit is ignored if the corresponding port is an input port or the unlock output.	I/O1 to I/O5, ULD																				
(9)	H/I6, L/I7	Counter input control Bits H/I-6 and L/I-7 select the operation of the HCTR/I-6 and LCTR/I-7 pins. When H/I-6 is 0, HCTR/I-6 is an input port, and when H/I-6 is 1, HCTR/I-6 is the HCTR input. When L/I-7 is 0, LCTR/I-7 is an input port, and when L/I-7 is 1, LCTR/I-7 is the LCTR input.	CTS0, CTS1																				
(10)	UL0, UL1	<p>PLL unlock detect control Bits UL0 and UL1 select the phase error threshold and extension (ϕE) used to detect the PLL unlocked state as shown in Table 10 and Figure 4. When the phase error is greater than the selected error, the PLL unlock detector output goes low.</p> <p>Table 10 Unlock detection and extension selection</p> <table border="1"> <thead> <tr> <th>UL1</th> <th>UL0</th> <th>Phase error</th> <th>Detector output</th> </tr> </thead> <tbody> <tr> <td>0</td> <td>0</td> <td>Stopped</td> <td>Open</td> </tr> <tr> <td>0</td> <td>1</td> <td>0</td> <td>ϕE output</td> </tr> <tr> <td>1</td> <td>0</td> <td>$\pm 0.56 \mu s$</td> <td>ϕE with 1 to 2 ms extension</td> </tr> <tr> <td>1</td> <td>1</td> <td>$\pm 1.11 \mu s$</td> <td>ϕE with 1 to 2 ms extension</td> </tr> </tbody> </table> <p style="text-align: center;">Figure 4 Phase-error extension</p>	UL1	UL0	Phase error	Detector output	0	0	Stopped	Open	0	1	0	ϕE output	1	0	$\pm 0.56 \mu s$	ϕE with 1 to 2 ms extension	1	1	$\pm 1.11 \mu s$	ϕE with 1 to 2 ms extension	ULD, DT0, DT1
UL1	UL0	Phase error	Detector output																				
0	0	Stopped	Open																				
0	1	0	ϕE output																				
1	0	$\pm 0.56 \mu s$	ϕE with 1 to 2 ms extension																				
1	1	$\pm 1.11 \mu s$	ϕE with 1 to 2 ms extension																				
(11)	XS	Crystal oscillator control Bit XS selects the oscillator frequency. When XS is 1, the frequency is 7.2 MHz, and when XS is 0, 4.5 MHz. 4.5 MHz is selected after power-on reset.																					
(12)	DZ0, DZ1	<p>Phase comparator control Bits DZ0 and DZ1 select the phase comparator insensitive band, or dead zone.</p> <p>Table 11 Insensitive band mode selection</p> <table border="1"> <thead> <tr> <th>DZ1</th> <th>DZ0</th> <th>Insensitive band (dead zone) mode</th> </tr> </thead> <tbody> <tr> <td>0</td> <td>0</td> <td>DZA</td> </tr> <tr> <td>0</td> <td>1</td> <td>DZB</td> </tr> <tr> <td>1</td> <td>0</td> <td>DZC</td> </tr> <tr> <td>1</td> <td>1</td> <td>DZD</td> </tr> </tbody> </table> <p>DZA is selected after power-on reset.</p>	DZ1	DZ0	Insensitive band (dead zone) mode	0	0	DZA	0	1	DZB	1	0	DZC	1	1	DZD						
DZ1	DZ0	Insensitive band (dead zone) mode																					
0	0	DZA																					
0	1	DZB																					
1	0	DZC																					
1	1	DZD																					
(13)	DLC	Charge pump control Bit DLC controls the charge pump operation. When DLC is 1, the charge pump outputs are forced to low, and when DLC is 0, the charge pump operates normally. This feature can be useful to remove the PLL from a deadlock state. The PLL can deadlock if its VCO control voltage V_{tune} becomes 0 V, halting the VCO. Setting DLC to 1 sets V_{tune} to V_{CC} , restarting the VCO. Normal operating mode is selected after power-on reset.																					
(14)	TBC	An 8 Hz 40% duty clock time base signal can be output from pins 0 to 7 by setting TBC to 1. When TBC is 1 the OUT7 data will be invalid. TBC is set to 0 by the power-on reset.	OUT7																				
(15)	TEST0 to TEST2	Test data Bits TEST0 to TEST2 are used for in-factory device testing. Set them all to 0. They are set to zero after a power-on reset.																					

Serial Data Output

The 40-bit data word output on DO has the format and functions as shown in Figure 5 and Table 12, respectively.

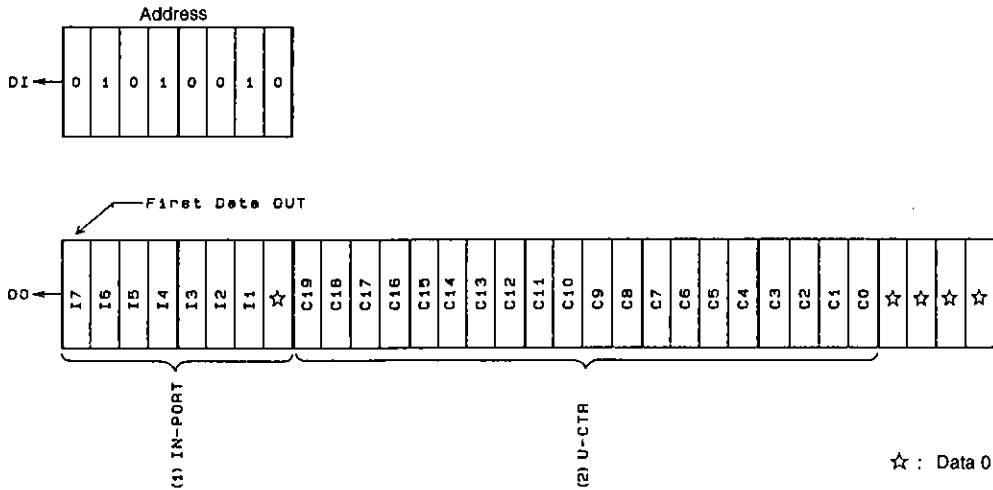

Figure 5 Output Data Word Out

A02683

Table 12 Input Data Functions

No.	Name	Function	Related bits
(1)	I1 to I7	Input port data Bits I-1 to I-7 reflect the data latched into each input port when the device changes to data output mode. I6 and I7 are zero when the corresponding port is a counter input. I1 to I5 correspond to the I/O1 to I/O5 ports, and I6 and I7, to the HCTR/I6 and LCTR/I7 inputs, respectively.	I/O-1 to I/O-5, H/I-6, L/I-7 OUT1 to OUT5
(2)	C0 to C19	Counter contents Bits C0 to C19 are the latched contents of the 20-bit binary counter. C19 is the msb. C0 is the lsb.	CTS0, CTS1, CTE

Serial Data Input/Output Mode Selection

The LC72146/M use the CCB (computer control bus) serial data format. The first eight bits form the address, shown in Figure 6, used to select the mode of operation as shown in Table 13.

Table 13 Serial Data Input/Output Mode Selection

Input/output mode	Address								Function
	B0	B1	B2	B3	A0	A1	A2	A3	
IN1	0	0	0	1	0	0	1	0	32-bit control data input
IN2	1	0	0	1	0	0	1	0	32-bit control data input
OUT	0	1	0	1	0	0	1	0	Output data. Data is output if the clock is active.

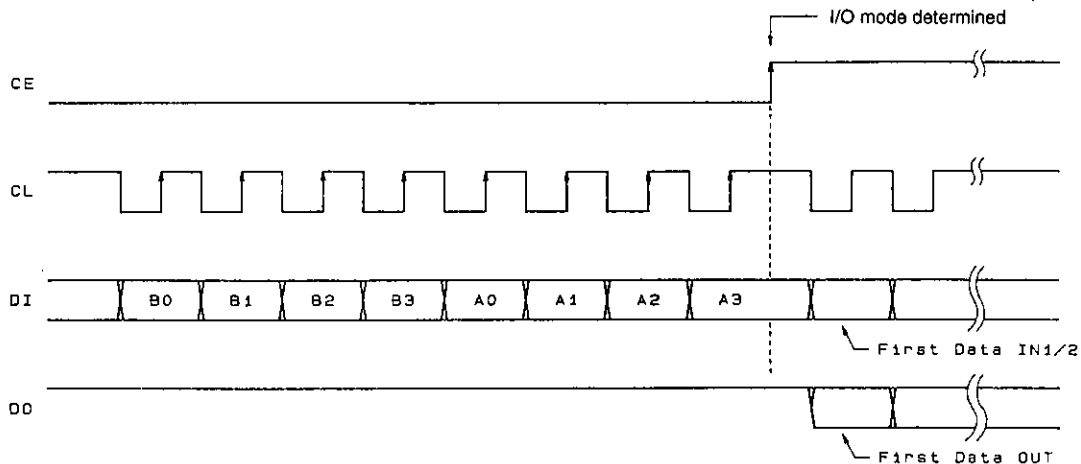
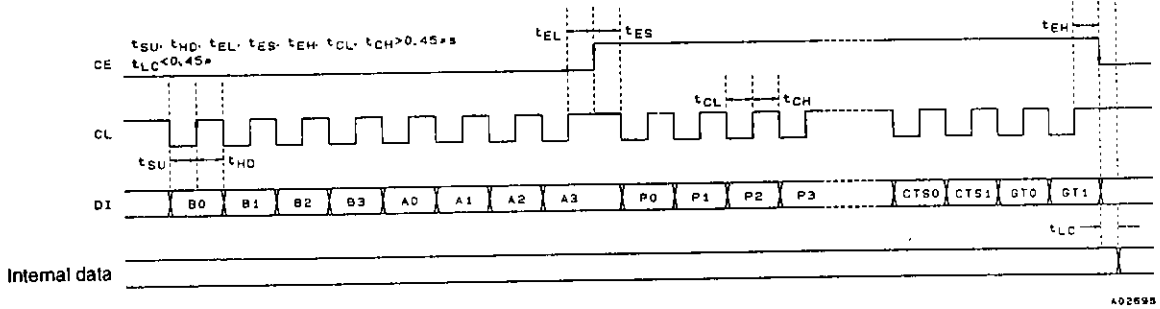

Figure 6 Mode Selection Address Bits

A02694

1. Serial data input (IN1/IN2)



2. Serial data output (OUT)

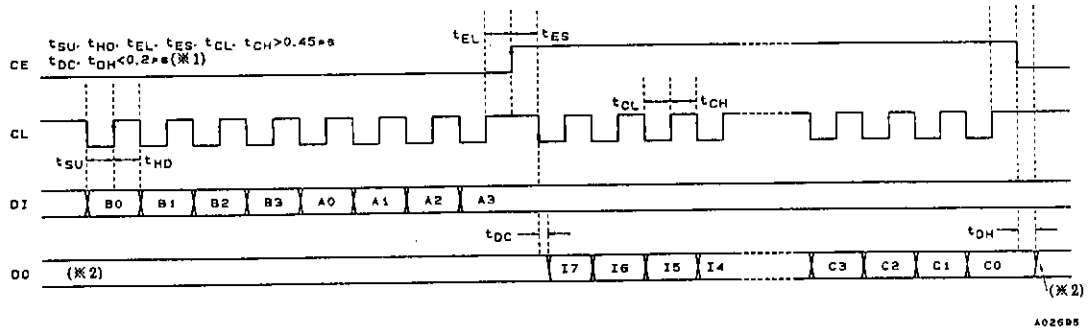

Note: 1. The data conversion time varies with the value of the pull-up resistor, since the DO pin is an n-channel open drain circuit.
 2. The DO pin is normally open.

Programmable Divider

The configuration of the programmable divider is shown in Figure 7. The input mode selection is shown in Table 14, and the input sensitivity, in Table 15.

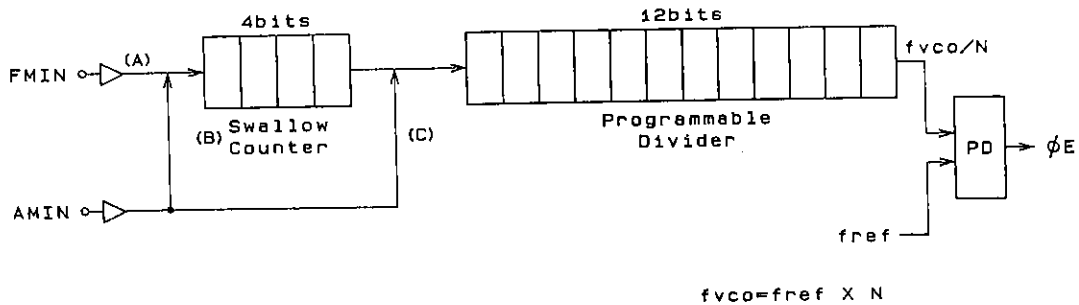

Figure 7 Programmable Divider

Table 14 Programmable Divider Selection

DVS	SNS	Divisor setting (NO)	Input frequency range	Input port
1	x	272 to 65535	10 to 160 MHz	FMIN
0	1	272 to 65535	2 to 40 MHz	AMIN
0	0	4 to 4095	0.5 to 10 MHz	AMIN

Note: x = don't care

Table 15 Input Sensitivity (Target Sensitivity)

	Minimum input sensitivity (f [MHz])		
	$10 \leq f < 50$	$50 \leq f < 130$	$130 \leq f < 160$
(A) FMIN	70 mVrms	40 mVrms	70 mVrms
(B) AMIN	40 mVrms	70 mVrms	—
(C) AMIN	40 mVrms	70 mVrms	—

CTC: Input sensitivity switching data. When CTC is 1 the input sensitivity is degraded. However, the actual values will be:

HCTR → 30 to 40 mVrms (frequency: 10.7 MHz)

LCTR → 10 to 15 mVrms (frequency: 450 kHz)

CTP: The input pull-down resistor (when CTE is 0) can be disabled by setting CTP to 1.

CTP must be set to 1 at least 4 ms before CTE is set to 1. CTP should be set to 0 if the counter is not used.

When CTP is set to 1 wait time is reduced at 1 to 2 ms.

The LC72146 includes a general-purpose 20-bit binary counter whose value can be read out from the DO pin, msb first. When using this counter for frequency measurement, one of four measurement times (4, 8, 32, or 64 ms) is selected by GT0 and GT1. The frequency input to either the HCTR or the LCTR pin can be measured by determining the number of pulses input to the counter during the measurement period.

This counter can be used to measure the period of the signal input to the LCTR pin by determining how many cycles of a reference signal (900 kHz) are input to the counter during one or two periods of the LCTR pin signal.

The counter is started by setting the serial data CTE bit to 1. While serial data is latched in the LC72146 when CE falls from high to low, input to the HCTR or the LCTR pin must be provided within the waiting period that follows CE being set low.

Next, after the measurement completes, the value of the counter must be read out during the period that CTE is 1. (The general-purpose counter is reset when CTE is set to 0.)

It should be emphasized here that the counter should be reset before measurement by setting CTE to 0.

Also note that although the signal input to the LCTR pin is input to the counter directly, the signal input to the HCTR pin is divided by two internally before being input to the counter. Accordingly, the value of the counter will be 1/2 the actual frequency input to the HCTR pin.

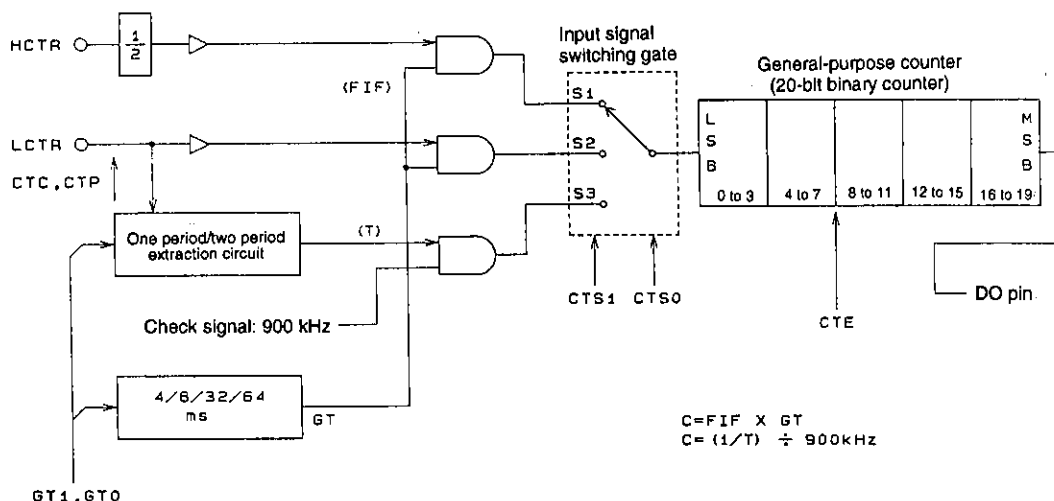

Figure 8 General-Purpose Counter

A02698

LC72146, 72146M

	CTS1	CTS0	Input pin	Measurement mode	Frequency range	Input sensitivity
S1	1	—	HCTR	Frequency	0.4 to 25.0 MHz	40 mVrms*
S2	0	1	LCTR	Frequency	10 to 500 kHz	40 mVrms*
S3	0	0	LCTR	Period	1.0 to 20 × 10 ³ Hz	(pulse)

Note: * CTC = 0: 40 mVrms
 CTC = 1: 70 mVrms
 However, the frequency ranges will be as follows when CTC is 1.
 HCTR: 8 to 12 MHz, LCTR: 400 to 500 kHz

GT1	GT0	Frequency measurement mode		Period measurement mode
		Measurement time (ms)	Wait time (ms)	
0	0	4	3 to 4	One period
0	1	8		
1	0	32	7 to 8	Two periods
1	1	64		

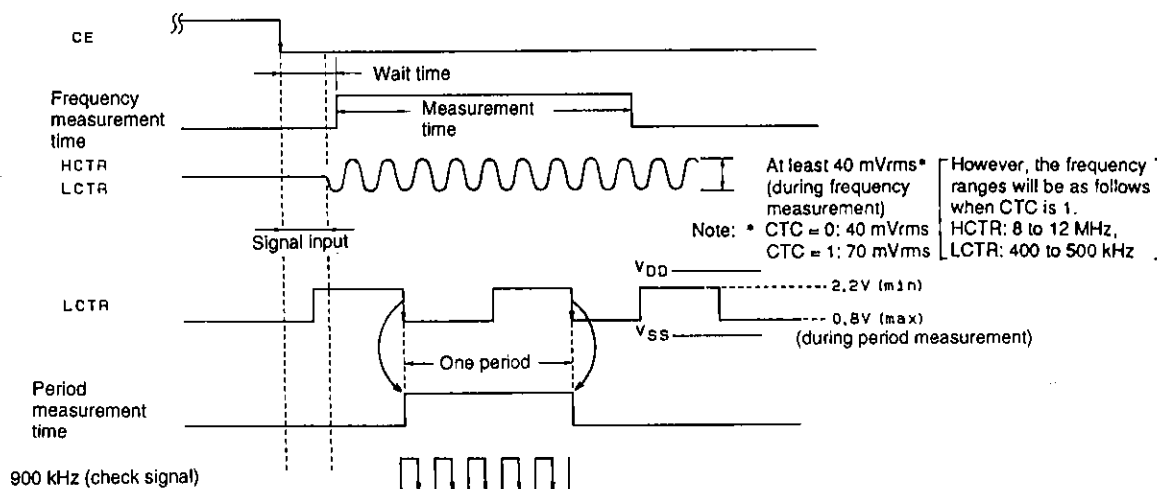

A02699

Integrating Count

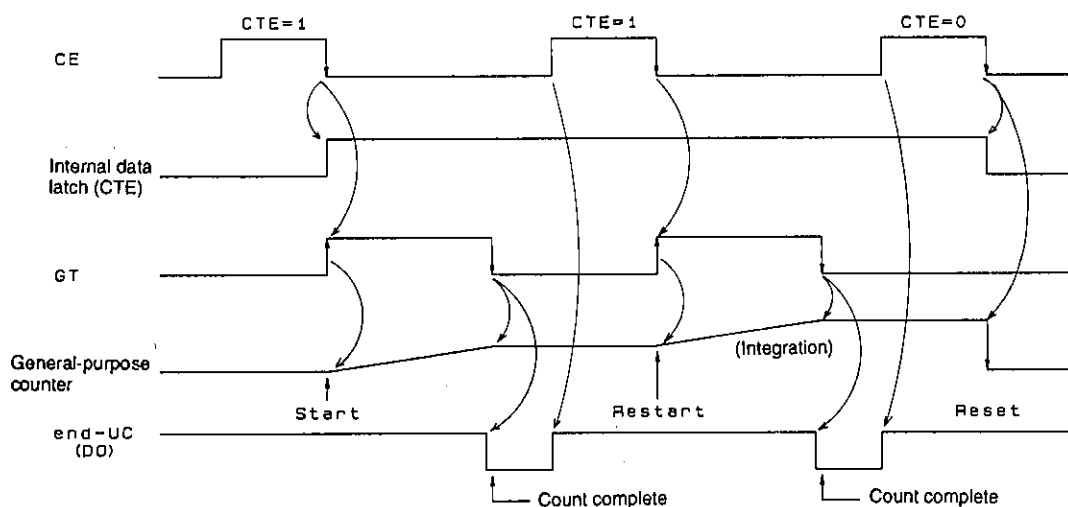

A02700

Note: CTE: 0 → • General-purpose counter reset
 1 → { • General-purpose counter start
 • Restarts on a new 1 setting

In integrated count mode, the count value is accumulated in the general-purpose counter.

Care is required to handle counter overflow.

Counter values: 0_H to FFFF_H (1,048,575)

To implement the integrating count operation leave CTE set to 1. When the serial data (IN1) is transmitted again, the general-purpose counter will start to measure the input again and the result will be added to the count.

Charge Pump

The charge pump configuration is shown in Figure 9.

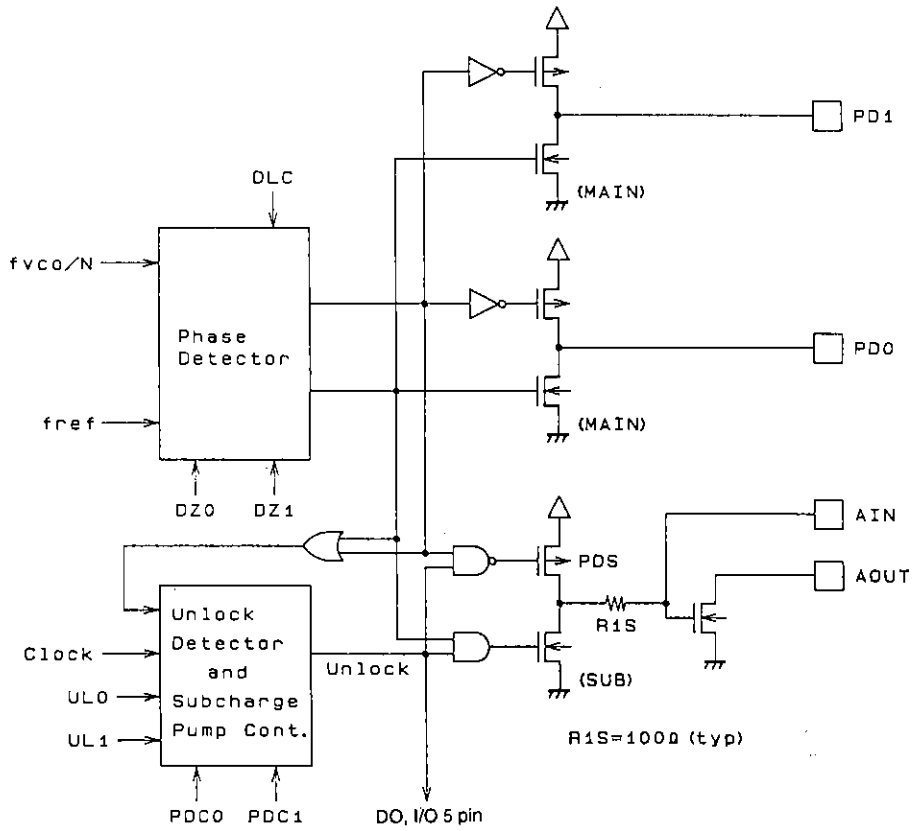

A02701

Figure 9 Charge Pump

PDC1	PDC0	PDS (sub-charge pump state)
0	—	High Impedance
1	1	Charge pump operates (normal operation)
1	0	Charge pump operates (when unlocked)

DLC	PD1, PD0, PDS
0	Normal operation
1	Forced to low

When unlock is detected following a channel change, PDS (the sub-charge pump) operates. The value of R1 changes to $R1M \parallel R1S$ ($R1S \approx 100 \Omega$), as shown in Figure 10, decreasing the low-pass filter time-constant and accelerating PLL locking.

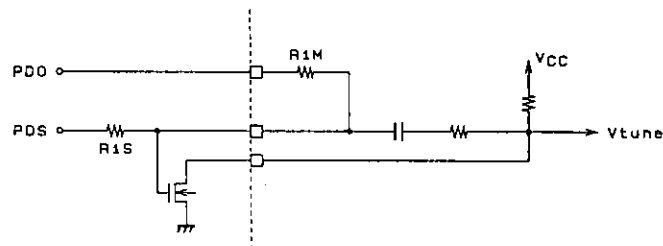

A02702

Figure 10 Charge Pump Connections

The unlock detection data UL1 must be set to 1. The unlock detection range will be set to $\pm 0.56 \mu\text{s}$ or $\pm 1.11 \mu\text{s}$. If a phase difference in excess of these values is detected the circuit will go to the unlock state and the sub-charge pump will operate. When the circuit approaches the lock state and the phase difference falls under the unlock detection range, the sub-charge pump operation will stop, i.e., the sub-charge pump will go to the high impedance state.

Note: 1. Notes on the phase comparator dead zone

DZ1	DZ0	Dead zone mode	Charge pump	Dead zone
0	0	DZA	ON/ON	-- -0 s
0	1	DZB	ON/ON	-0 s
1	0	DZC	OFF/OFF	+0 s
1	1	DZD	OFF/OFF	+ +0 s

Cases where the charge pump is in the ON/ON state require special care during system design since the charge pump outputs correction pulses even when the PLL is locked and it is easy for the loop to become unstable. The following problems may occur in the ON/ON state.

- ① Sidebands may be generated by reference frequency leakage.
 - ② Sidebands may be generated by low frequency leakage due to the correction pulse envelope.
- The settings that have a dead zone (the OFF/OFF settings) provide good loop stability, but it is hard to achieve a good S/N ratio with these settings. Inversely, the settings with no dead zone (the ON/ON settings) allow a high S/N ratio to be achieved but it is hard to achieve good loop stability with these settings. Therefore, it can be effective to select either the DZA or DXB setting, i.e., a setting which has no dead zone, when an S/N ratio of between 90 and 100 dB or higher is required in FM mode, or when the AM stereo pilot margin needs to be increased. However, in cases where such a high FM S/N ratio is not required and where an adequate AM stereo pilot margin can be achieved or AM stereo is not used, either the DZC or DZD setting, i.e., a setting which has a dead zone, should be selected.

Dead Zone Definition

The phase comparator compares f_p with a reference frequency (f_r) as shown in Figure 11. Figure 12 shows the characteristics of an ideal phase comparator, which outputs an output voltage (A) that is proportional to the phase difference ϕ . However, in an actual IC, a region (dead zone) in which minute phase differences cannot be detected occurs due to internal circuit delays and other factors. To implement an end product with a high S/N ration, the dead zone should be as small as possible.

However, there are cases where a larger dead zone can make a popularly-priced model easier to use. This is because it is possible for RF leakage from the mixer to the VCO to modulate the VCO in popularly-priced models when a strong RF input is applied. When the dead zone is small an output that compensates for this problem is generated, and this output may itself modulate the VCO and generate beating with the RF frequency.

Application System Example

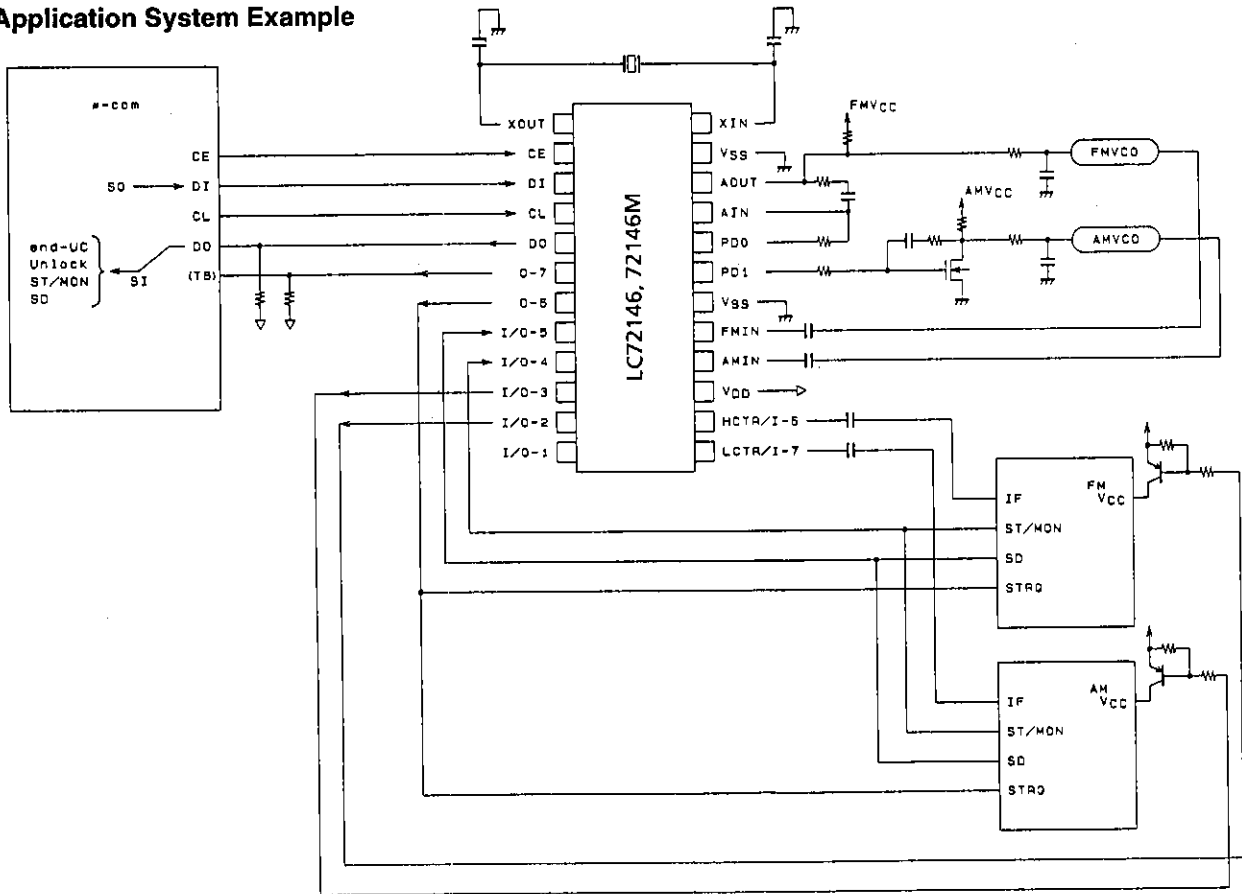

A02704

Note on Clock Time Base Usage

A resistor of at least 100 kΩ must be used as the clock time base output pin (O-7) pull-up resistor. Also, the use of a Schmitt circuit is recommended in the controller (microprocessor) input circuit to prevent chattering. Forming a loop filter with the built-in low-pass filter transistor will also serve to prevent degradation of the VCO C/N characteristics. Since the grounding points for the clock time base output pin and the low-pass filter transistor are a common point within the IC, current fluctuations in the clock time base output pin must be kept to a minimum to limit influencing the low-pass filter.

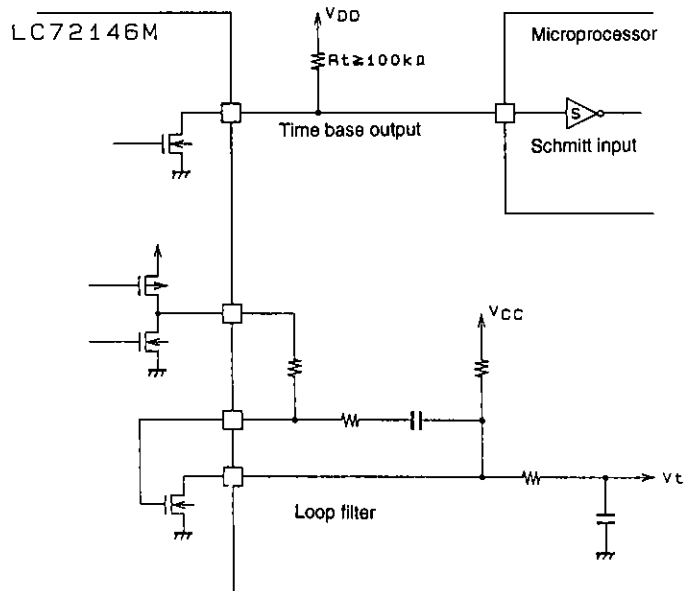

A02705

Serial Data Timing

When CL is stopped at the low level

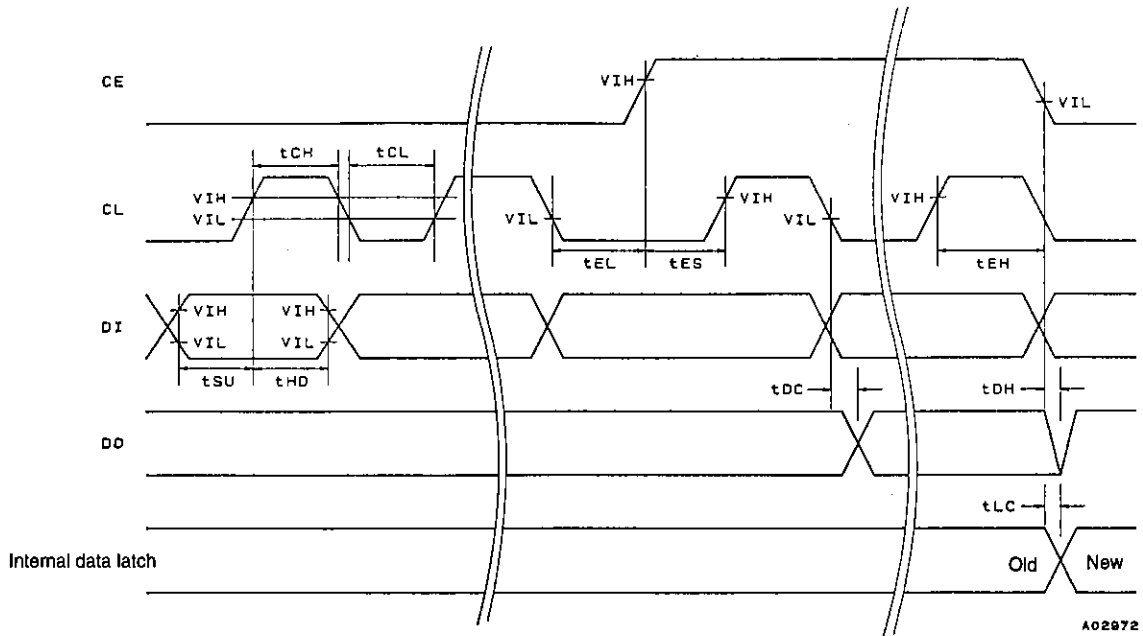

A02872

When CL is stopped at the high level

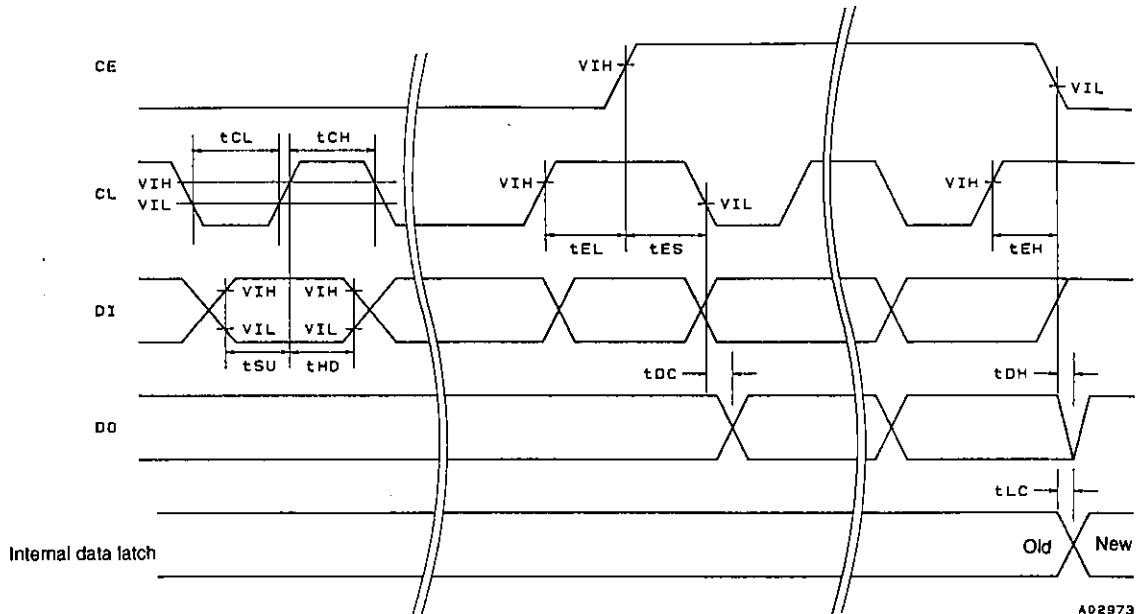

A02873

- No products described or contained herein are intended for use in surgical implants, life-support systems, aerospace equipment, nuclear power control systems, vehicles, disaster/crime-prevention equipment and the like, the failure of which may directly or indirectly cause injury, death or property loss.
- Anyone purchasing any products described or contained herein for an above-mentioned use shall:
 - ① Accept full responsibility and indemnify and defend SANYO ELECTRIC CO., LTD., its affiliates, subsidiaries and distributors and all their officers and employees, jointly and severally, against any and all claims and litigation and all damages, cost and expenses associated with such use:
 - ② Not impose any responsibility for any fault or negligence which may be cited in any such claim or litigation on SANYO ELECTRIC CO., LTD., its affiliates, subsidiaries and distributors or any of their officers and employees jointly or severally.
- Information (including circuit diagrams and circuit parameters) herein is for example only; it is not guaranteed for volume production. SANYO believes information herein is accurate and reliable, but no guarantees are made or implied regarding its use or any infringements of intellectual property rights or other rights of third parties.

This catalog provides information as of July, 1996. Specifications and information herein are subject to change without notice.