

## LM388 1.5W Audio Power Amplifier

### General Description

The LM388 is an audio amplifier designed for use in medium power consumer applications. The gain is internally set to 20 to keep external part count low, but the addition of an external resistor and capacitor between pins 2 and 6 will increase the gain to any value up to 200.

The inputs are ground referenced while the output is automatically biased to one half the supply voltage.

### Features

- Minimum external parts
- Wide supply voltage range
- Excellent supply rejection
- Ground referenced input
- Self-centering output quiescent voltage
- Variable voltage gain
- Low distortion
- Fourteen pin dual-in-line package
- Low voltage operation, 4V

### Applications

- AM-FM radio amplifiers
- Portable tape player amplifiers
- Intercoms
- TV sound systems
- Lamp drivers
- Line drivers
- Ultrasonic drivers
- Small servo drivers
- Power converters

### Equivalent Schematic and Connection Diagrams

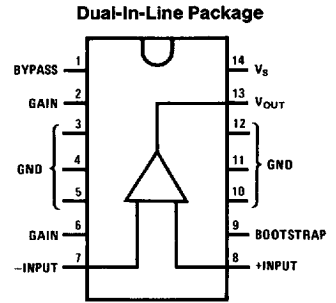
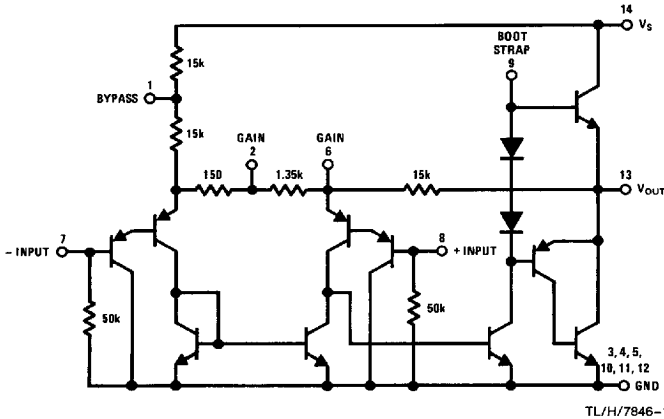

Top View

Order Number LM388N-1  
See NS Package Number N14A

## Absolute Maximum Ratings

If Military/Aerospace specified devices are required, please contact the National Semiconductor Sales Office/Distributors for availability and specifications.

Supply Voltage	15V
Package Dissipation 14-Pin DIP (Note 1)	8.3W
Input Voltage	$\pm 0.4V$
Storage Temperature	$-65^{\circ}C$ to $+150^{\circ}C$

Operating Temperature	$0^{\circ}C$ to $+70^{\circ}C$
Junction Temperature	$150^{\circ}C$
Lead Temperature (Soldering, 10 sec.)	$260^{\circ}C$
Thermal Resistance	
$\theta_{JC}$	$30^{\circ}C/W$
$\theta_{JA}$	$79^{\circ}C/W$

## Electrical Characteristics $T_A = 25^{\circ}C$ , (Figure 1)

Symbol	Parameter	Conditions	Min	Typ	Max	Units
$V_S$	Operating Supply Voltage LM388		4		12	V
$I_Q$	Quiescent Current LM388	$V_{IN} = 0$ $V_S = 12V$		16	23	mA
$P_{OUT}$	Output Power (Note 2) LM388N-1	$R_1 = R_2 = 180\Omega$ , THD = 10% $V_S = 12V$ , $R_L = 8\Omega$ $V_S = 6V$ , $R_L = 4\Omega$	1.5 0.6	2.2 0.8		W W
$A_V$	Voltage Gain	$V_S = 12V$ , $f = 1$ kHz $10 \mu F$ from Pins 2 to 6	23	26 46	30	dB dB
BW	Bandwidth	$V_S = 12V$ , Pins 2 and 6 Open		300		kHz
THD	Total Harmonic Distortion	$V_S = 12V$ , $R_L = 8\Omega$ , $P_{OUT} = 500$ mW, $f = 1$ kHz, Pins 2 and 6 Open		0.1	1	%
PSRR	Power Supply Rejection Ratio (Note 3)	$V_S = 12V$ , $f = 1$ kHz, $C_{BYPASS} = 10 \mu F$ , Pins 2 and 6 Open, Referred to Output		50		dB
$R_{IN}$	Input Resistance		10	50		k $\Omega$
$I_{BIAS}$	Input Bias Current	$V_S = 12V$ , Pins 7 and 8 Open		250		nA

Note 1: Pins 3, 4, 5, 10, 11, 12 at  $25^{\circ}C$ . Derate at  $15^{\circ}C/W$  above  $25^{\circ}C$  case.

Note 2: The amplifier should be in high gain for full swing on higher supplies due to input voltage limitations.

Note 3: If load and bypass capacitor are returned to  $V_S$  (Figure 2), rather than ground (Figure 1), PSRR is typically 30 dB.

## Typical Performance Characteristics

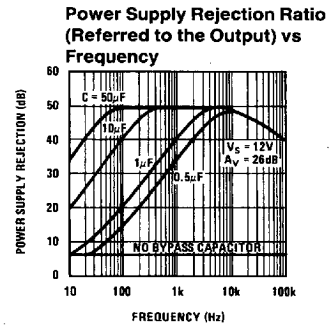
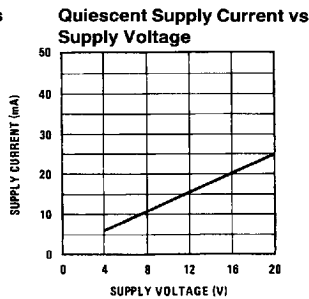
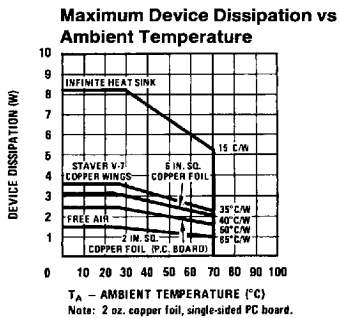

TL/H/7846-5

## Typical Performance Characteristics (Continued)

**Peak-to-Peak Output Voltage Swing vs Supply Voltage**

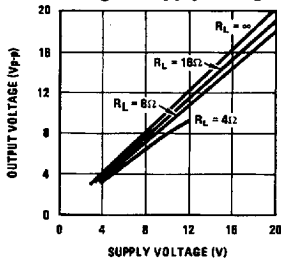

**Voltage Gain vs Frequency**

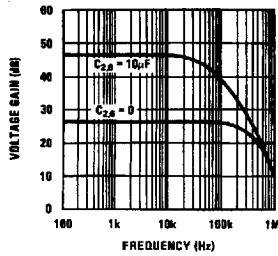

**Distortion vs Frequency**

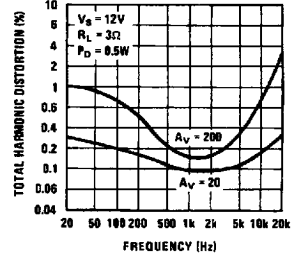

**Distortion vs Output Power**

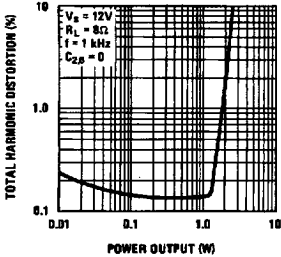

**Device Dissipation vs Output Power—4 Ohm Load**

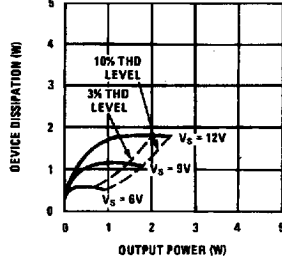

**Device Dissipation vs Output Power—8 Ohm Load**

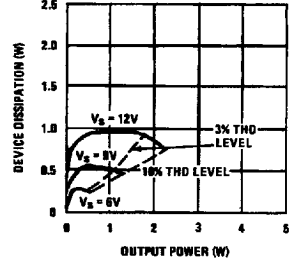

**Device Dissipation vs Output Power—16 Ohm Load**

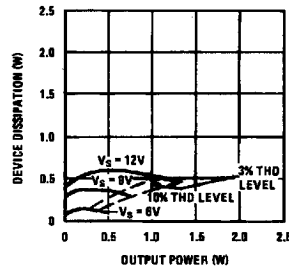

TL/H/7846-6

## Application Hints

### GAIN CONTROL

To make the LM388 a more versatile amplifier, two pins (2 and 6) are provided for gain control. With pins 2 and 6 open, the 1.35 k $\Omega$  resistor sets the gain at 20 (26 dB). If a capacitor is put from pins 2 to 6, bypassing the 1.35 k $\Omega$  resistor, the gain will go up to 200 (46 dB). If a resistor is placed in series with the capacitor, the gain can be set to any value from 20 to 200. A low frequency pole in the gain response is caused by the capacitor working against the external resistor in series with the 150 $\Omega$  internal resistor. If the capacitor is eliminated and a resistor connects pins 2 to 6 then the

output dc level may shift due to the additional dc gain. Gain control can also be done by capacitively coupling a resistor (or FET) from pin 6 to ground, as in Figure 7.

Additional external components can be placed in parallel with the internal feedback resistors to tailor the gain and frequency response for individual applications. For example, we can compensate poor speaker bass response by frequency shaping the feedback path. This is done with a series RC from pin 6 to 13 (paralleling the internal 15 k $\Omega$  resistor). For 6 dB effective bass boost:  $R \approx 15$  k $\Omega$ , the lowest value for good stable operation is  $R = 10$  k $\Omega$  if pin 2

## Application Hints (Continued)

is open. If pins 2 and 6 are bypassed then R as low as 2 k $\Omega$  can be used. This restriction is because the amplifier is only compensated for closed-loop gains greater than 9 V/V.

### INPUT BIASING

The schematic shows that both inputs are biased to ground with a 50 k $\Omega$  resistor. The base current of the input transistors is about 250 nA, so the inputs are at about 12.5 mV when left open. If the dc source resistance driving the LM388 is higher than 250 k $\Omega$  it will contribute very little additional offset (about 2.5 mV at the input, 50 mV at the output). If the dc source resistance is less than 10 k $\Omega$ , then shorting the unused input to ground will keep the offset low (about 2.5 mV at the input, 50 mV at the output). For dc source resistances between these values we can eliminate excess offset by putting a resistor from the unused input to ground, equal in value to the dc source resistance. Of course all offset problems are eliminated if the input is capacitively coupled.

When using the LM388 with higher gains (bypassing the 1.35 k $\Omega$  resistor between pins 2 and 6) it is necessary to bypass the unused input, preventing degradation of gain and possible instabilities. This is done with a 0.1  $\mu$ F capacitor or a short to ground depending on the dc source resistance on the driven input.

### BOOTSTRAPPING

The base of the output transistor of the LM388 is brought out to pin 9 for Bootstrapping. The output stage of the amplifier during positive swing is shown in *Figure 3* with its external circuitry.

R1 + R2 set the amount of base current available to the output transistor. The maximum output current divided by

beta is the value required for the current in R1 and R2:

$$(R1 + R2) = \beta_O \frac{(V_S/2) - V_{BE}}{I_{O\text{ MAX}}}$$

Good design values are  $V_{BE} = 0.7\text{V}$  and  $\beta_O = 100$ .

Example: 1 watt into 8 $\Omega$  load with  $V_S = 12\text{V}$ .

$$I_{O\text{ MAX}} = \sqrt{\frac{2 P_O}{R_L}} = 500\text{ mA}$$

$$(R1 + R2) = 100 \left( \frac{(12/2) - 0.7}{0.5} \right) = 1060\Omega$$

To keep the current in R2 constant during positive swing capacitor  $C_B$  is added. As the output swings positive  $C_B$  lifts R1 and R2 above the supply, maintaining a constant voltage across R2. To minimize the value of  $C_B$ ,  $R1 = R2$ . The pole due to  $C_B$  and R1 and R2 is usually set equal to the pole due to the output coupling capacitor and the load. This gives:

$$C_B \approx \frac{4C_C}{\beta_O} \approx \frac{C_C}{25}$$

Example: for 100 Hz pole and  $R_L = 8\Omega$ ;  $C_C = 200\ \mu\text{F}$  and  $C_B = 8\ \mu\text{F}$ , if R1 is made a diode and R2 increased to give the same current,  $C_B$  can be decreased by about a factor of 4, as in *Figure 4*.

For reduced component count the load can replace R1. The value of (R1 + R2) is the same, so R2 is increased. Now  $C_B$  is both the coupling and the bootstrapping capacitor (see *Figure 2*).

## Typical Applications

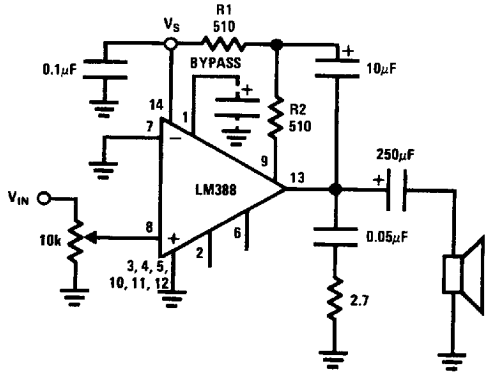

TL/H/7846-3

FIGURE 1. Load Returned to Ground  
(Amplifier with Gain = 20)

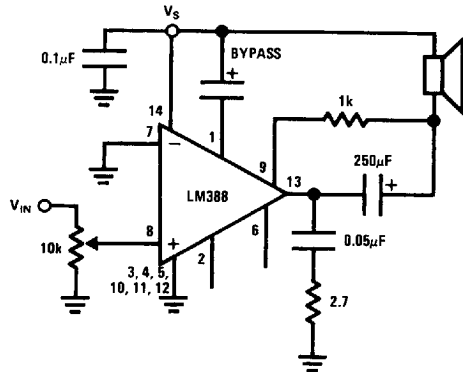

TL/H/7846-4

FIGURE 2. Load Returned to  $V_S$   
(Amplifier with Gain = 20)

Typical Applications (Continued)

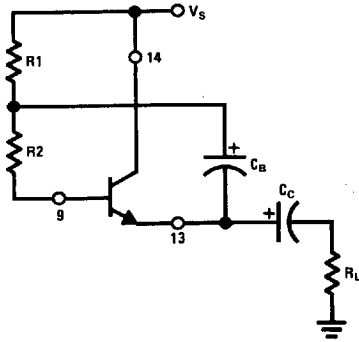

FIGURE 3

TL/H/7846-7

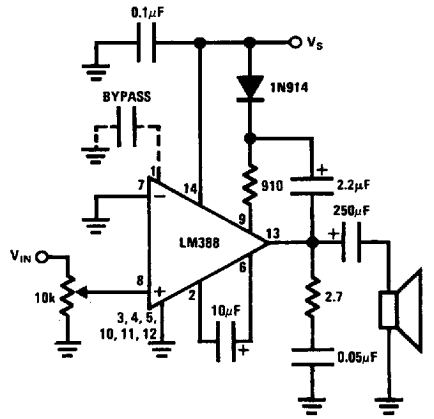
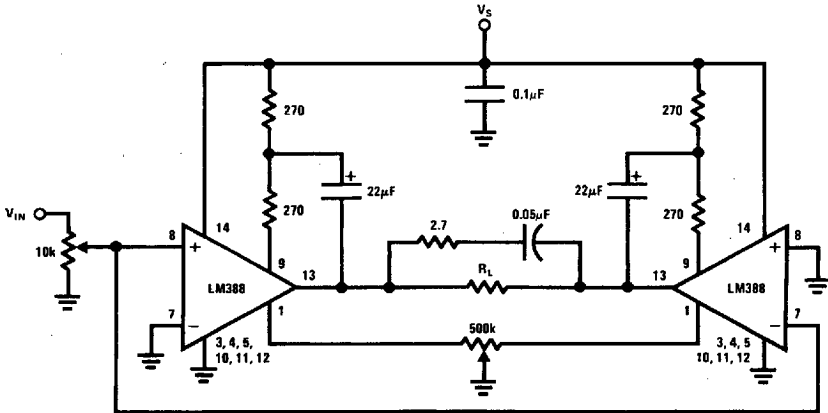

FIGURE 4. Amplifier with Gain = 200 and Minimum  $C_B$

TL/H/7846-8



$V_S = 6V$   
 $V_S = 12V$

$R_L = 4\Omega$   
 $R_L = 8\Omega$

$P_O = 1.0W$   
 $P_O = 4W$

TL/H/7846-9

FIGURE 5. Bridge Amp

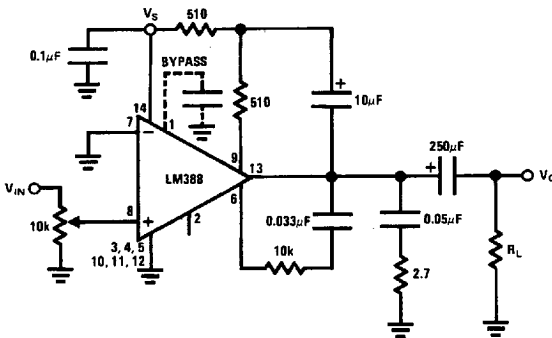
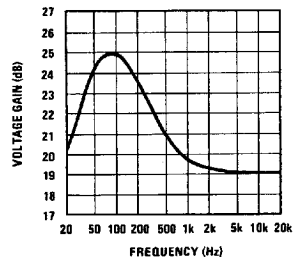

FIGURE 6a. Amplifier with Bass Boost

TL/H/7846-10



TL/H/7846-11

FIGURE 6b. Frequency Response with Bass Boost

Typical Applications (Continued)

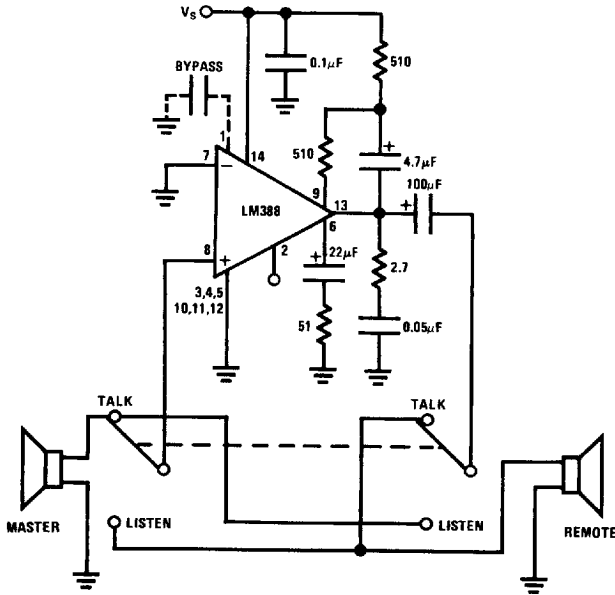

FIGURE 7. Intercom

TL/H/7846-12

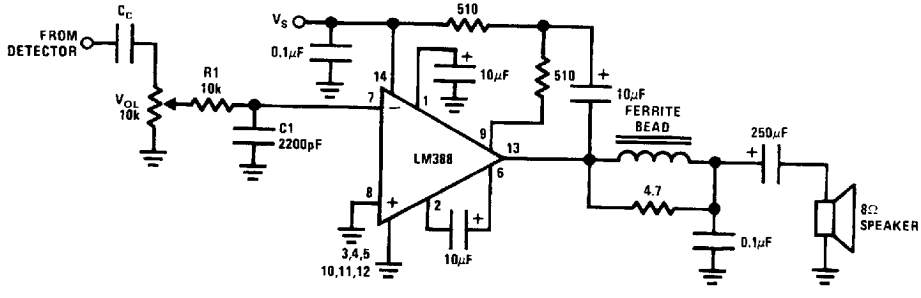

FIGURE 8. AM Radio Power Amplifier

TL/H/7846-13

- Note 1: Twist supply lead and supply ground very tightly.
- Note 2: Twist speaker lead and ground very tightly.
- Note 3: Ferrite bead is Ferroxcube K5-001-001/3B with 3 turns of wire.

- Note 4: R1C1 band limits input signals.
- Note 5: All components must be spaced very close to IC.