

M5222L/P/FP

DUAL VCA FOR LOW VOLTAGE ELECTRONIC VOLUME CONTROL

DESCRIPTION

The M5222 is a dual VCA designed as an electronic volume control capable of operating in a wide supply voltage range between 1.8V to 20V.

The IC is an optimum device for electronic equipment requiring low voltage operation, such as video movie systems.

FEATURES

- Capable of operating at low voltage..... $V_{cc} = 1.8$ to 20V
- Two built-in channels
 - Simultaneous control of both channels is possible with V_c (control) at pin ⑤
- Logarithmic response VCA
 - Logarithmic response equivalent to A-curve volume
- Large ATT range..... 0dB($V_c \approx 0$) to -90dB ($V_c \approx -270mV$)(typ)
- High maximum input voltage
 - $V_i = 1.0V_{rms}$ (typ)(@ $V_{cc} = 3V$)
- Low distortion ratio..... THD = 0.05 %
- Similar characteristics between 2 channels



Outline 8P5(L)

2.54mm pitch 340mil SIP
(2.8mm × 19.0mm × 6.4mm)



Outline 8P4(P)

2.54mm pitch 300mil DIP
(6.3mm × 8.9mm × 3.3mm)



Outline 8P2S-A(FP)

1.27mm pitch 225mil SOP
(4.4mm × 5.0mm × 1.5mm)

RECOMMENDED OPERATING CONDITIONS

Supply voltage range..... $V_{cc} = 1.8$ to 20V

Rated dissipation voltage

..... 800(L), 625(P), 440(FP)mW

SYSTEM CONFIGURATION

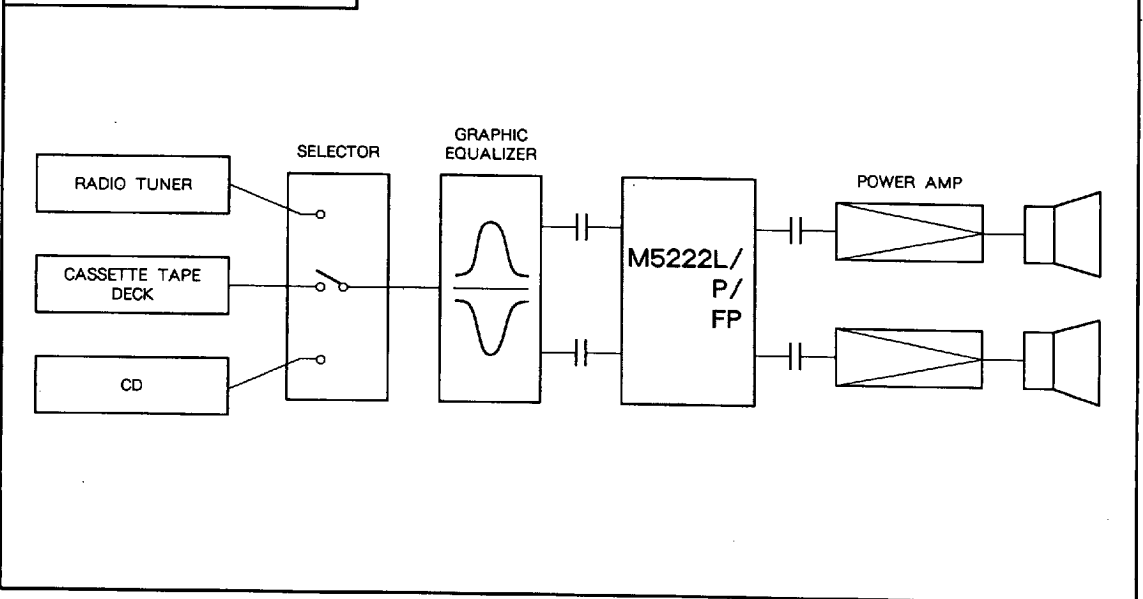

6249826 0022322 717



M5222L/P/FP

DUAL VCA FOR LOW VOLTAGE ELECTRONIC VOLUME CONTROL

PIN CONFIGURATION (TOP VIEW)

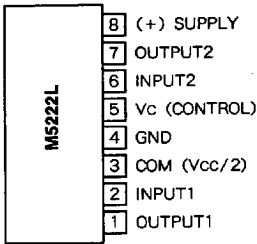

Outline 8P5 (L)



Outline 8P4(P)
8P2S-A(FP)

IC INTERNAL BLOCK DIAGRAM

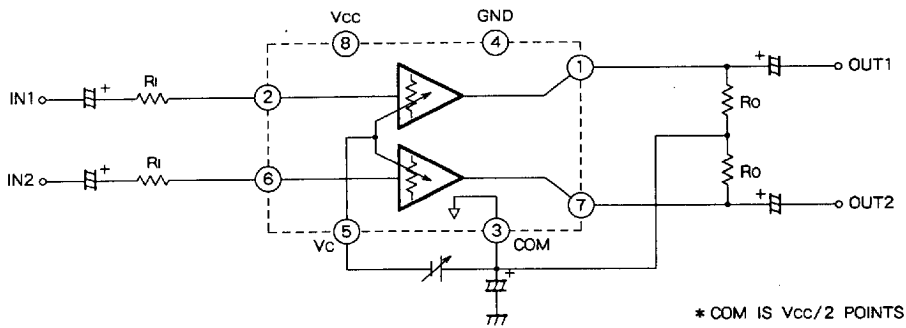

Note 1. R_i is used to convert input voltage to current.

2. R_o is an output resistor used to convert the current output signal to voltage. Connect this output with COM pin 3 to fix the DC output potential.

3. The COM pin is used for making a 1/2 pint supply voltage within the IC. It is used in connecting R_o and in Vc control.

6249826 0022323 653



DUAL VCA FOR LOW VOLTAGE ELECTRONIC VOLUME CONTROL

ABSOLUTE MAXIMUM RATINGS (Ta = 25 °C, unless otherwise noted)

Symbol	Parameter	Ratings	Unit
V _{cc}	Supply voltage	20	V
P _d	Power dissipation	800 (SIP)/625 (DIP)/440 (FP)	mW
K _θ	Thermal derating (Ta ≥ 25 °C)	8 (SIP)/6.25 (DIP)/4.4 (FP)	mW/°C
T _{opr}	Operating temperature	- 20 to + 75	°C
T _{stg}	Storage temperature	- 55 to + 125	°C

ELECTRICAL CHARACTERISTICS (Ta = 25 °C, unless otherwise noted)

Symbol	Parameter	Test conditions	V _{cc}	Limits			Unit
				Min	Typ	Max	
I _{cc}	Circuit current	V _i = 0, V _c = 0	3V	2.5	3.6	5.5	mA
V _{iM1}	Maximum input voltage	f = 1kHz V _c = 0	3V	0.7	1.0	-	V _{rms}
V _{iM2}	Maximum input voltage	THD = 1 % R _i = 50k Ω R _o = 100k Ω	9V	2.3	3.4	-	V _{rms}
ATT _M	Maximum attenuation	R _i = 10k Ω, R _o = 20k Ω V _c = - 270mV	3V	80	90	-	dB
ATT ₀₁	Attenuation error	f = 1kHz V _c = 0	3V	- 4.4	- 1.4	+ 1.6	dB
ATT ₀₂	Attenuation error	V _i = 0dBm R _i = 50k Ω R _o = 100k Ω	9V	- 5.0	- 2.0	+ 1.0	dB
Δ ATT	Attenuation deviation between channels	f = 1kHz, V _c = 0, V _i = 0dBm R _i = 10k Ω, R _o = 20k Ω	3V	-	0.1	3.0	dB
V _{NO1}	Noise output voltage	V _c = 0, R _i = 10k Ω R _o = 20k Ω, BW = 20Hz to 20kHz	3V	-	30	60	μ V _{rms}
V _{NO2}	Noise output voltage	ATT = - 40dB, R _i = 10k Ω R _o = 20k Ω, BW = 20Hz to 20kHz	3V	-	5	-	μ V _{rms}

TEST CIRCUIT

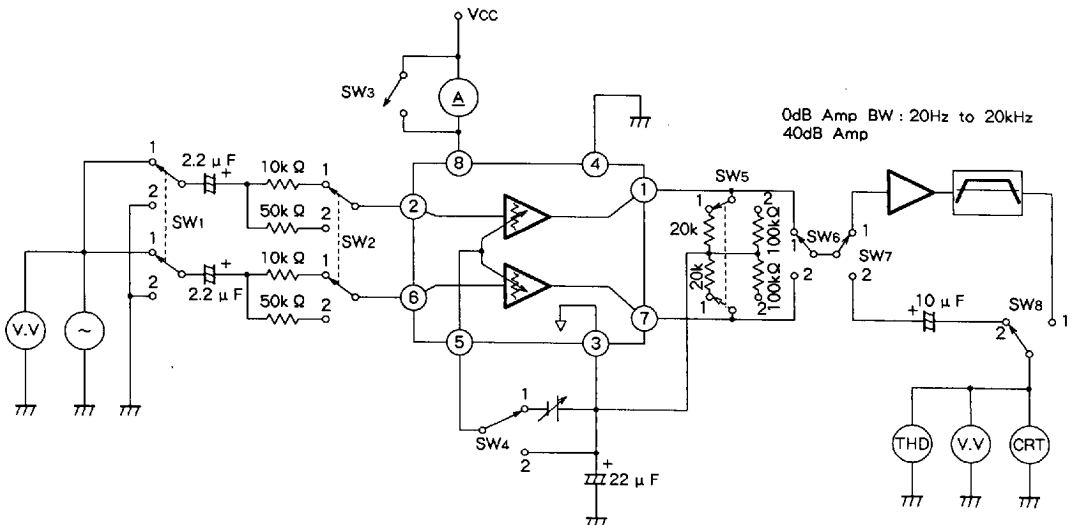

6249826 0022324 59T



DUAL VCA FOR LOW VOLTAGE ELECTRONIC VOLUME CONTROL

SWITCH MATRIX

Parameter	SW ₁	SW ₂	SW ₃	SW ₄	SW ₅	SW ₆	SW ₇	SW ₈
I _{cc}	2	1	OFF	2	1	1/2	2	2
V _{IM}	1	1	ON	2	1	1/2	1	1
	2	1	ON	2	2	1/2	1	1
ATTM	1	1	ON	1	1	1/2	2	2
ATT	01	1	ON	2	1	1/2	2	2
	02	1	ON	2	2	1/2	2	2
V _{No}	1	2	ON	2	1	1/2	1	1
	2	2	ON	1	1	1/2	1	1

- Note 1. Use 0dB amplification when measuring V_{IM}
- 2. Use 40dB amplification when measuring V_{No}
- 3. V_{No} = measurement value/100 (40dB) [μ Vrms]

TYPICAL CHARACTERISTICS

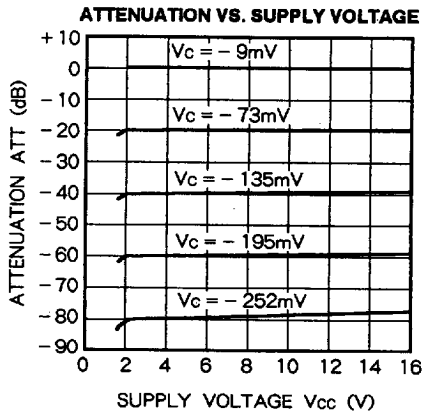
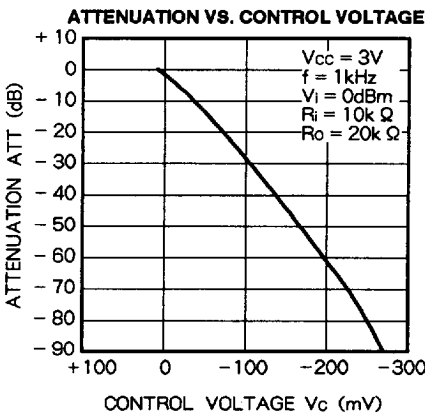
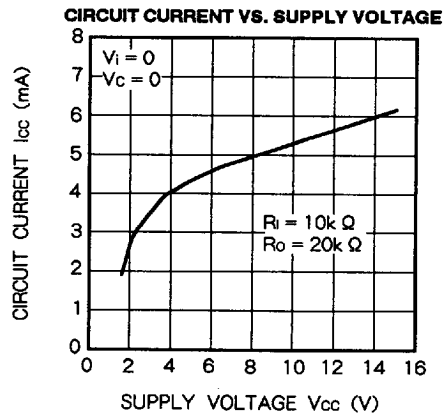
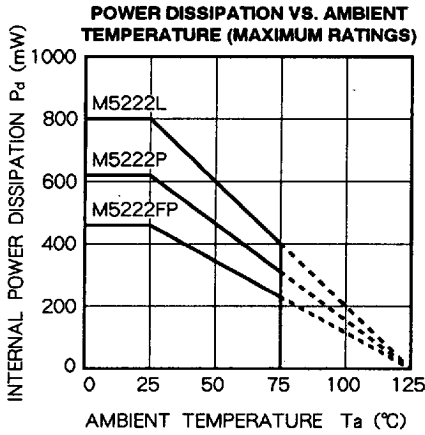

6249826 0022325 426



DUAL VCA FOR LOW VOLTAGE ELECTRONIC VOLUME CONTROL

CONTROL VOLTAGE VS. SUPPLY VOLTAGE

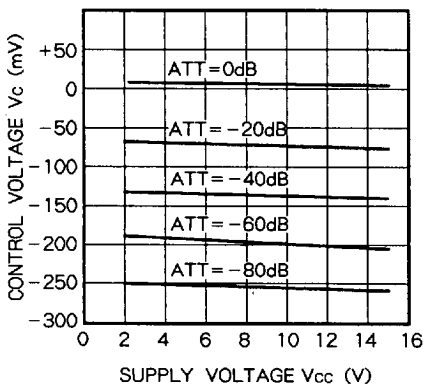

TOTAL HARMONIC DISTORTION VS. INPUT VOLTAGE

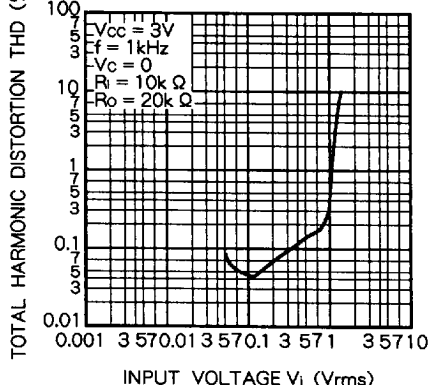

TOTAL HARMONIC DISTORTION VS. INPUT VOLTAGE

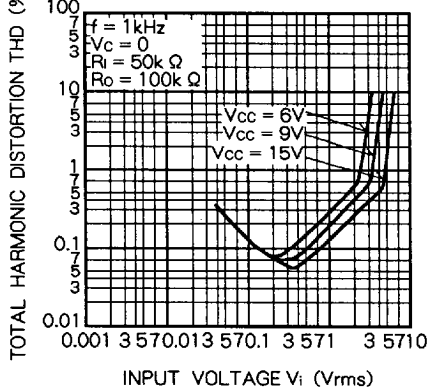

NOISE OUTPUT VOLTAGE VS. ATTENUATION

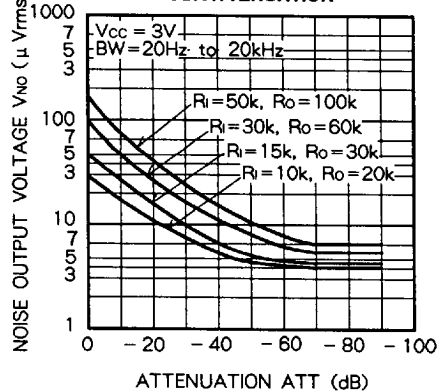

ATTENUATION VS. FREQUENCY

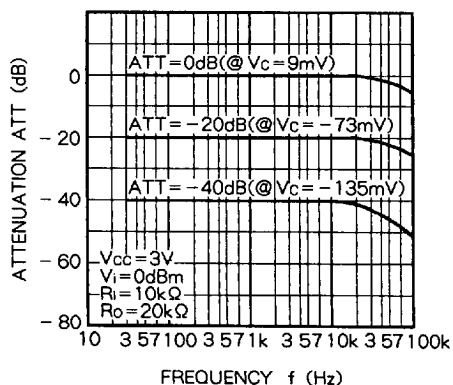

ATTENUATION VS. AMBIENT TEMPERATURE

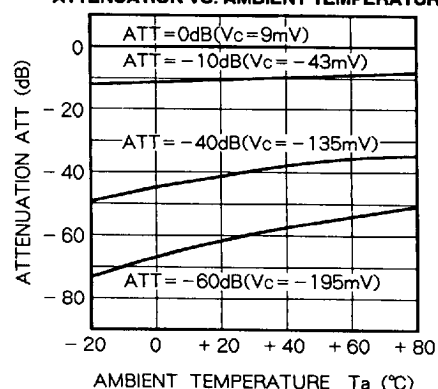

6249826 0022326 362



DUAL VCA FOR LOW VOLTAGE ELECTRONIC VOLUME CONTROL

BASIC PRINCIPLE OF OPERATION

The M5222 is a current input, current output type of VCA IC. This amplifier uses the principle by which changing the balance of the differential circuit with external control voltage

V_c will change gm. The circuit is also called a variable transconductance (variable gm) OP amp. The basic principle of operation will be simply explained below.

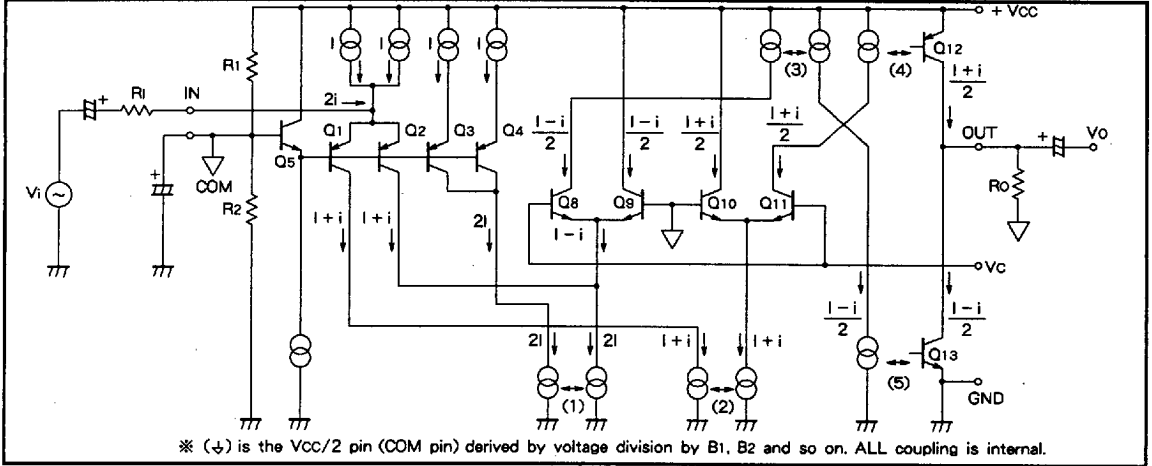

Fig. 1 M5222 Equivalent circuit

Basic voltage-current conversion mechanism for input and output

Applying the input signal V_i which flows through external input resistor R_i results in a change to a current signal at input terminal IN. The V_{BE} level shift of R_1 , R_2 , Q_5 , Q_1 , and Q_2 will cause input pin IN to become ground level by means of $V_{cc}/2$ in terms of direct current and to become ground level by means of the externally-connected capacitor in terms of alternating current. The signal input in this way will be sent to the output pin as a current signal by the current mirror and differential circuit. By taking this current signal through the externally-connected output resistor (load resistor), the signal can go through a current-to-voltage conversion and be obtained as output signal V_o .

The output transistors combine the currents by means of the joined PNP and NPN collector circuits. Basically, the DC potential floats and is not determined in this joining of currents. This is why one end of externally-connected resistor R_o is connected to the $V_{cc}/2$ pin and the DC level ($V_{cc}/2$) at the time of no signal is set.

Basic mechanism of attenuation

The output is controlled by means of changing the control voltage applied to the V_c pin with respect to the COM pin ($V_{cc}/2$ pin). By applying voltage from the COM pin to the base of one side of a differential circuit and applying voltage from the V_c pin to the other base, the current distribution of the differential circuit is changed and the gain of this circuit is changed.

Let us first consider when V_c equals zero ($V_c - COM$ is shorted). Input signal V_i is converted to current by input

resistor R_i and the i currents ($2i = V_i/R_i$) flow through the collectors of Q_1 and Q_2 . When the current flowing in Q_1 becomes $i+i$, the overall emitter current of the differential circuit consisting of Q_{10} and Q_{11} will also be determined as $i+i$ by means of current mirror (2). Since the base potential of Q_{10} and Q_{11} is the same, the current will be divided equally and current $(i+i)/2$ will flow in each of Q_{10} and Q_{11} . The current of current mirror (4) will also be determined as $(i+i)/2$ because of this.

Since the current of current mirror (1) is determined as $2i$ by the current flowing in Q_3 and Q_4 , the total of the current flowing in Q_2 and the current flowing in differential circuit Q_8 , Q_9 will also be $2i$. The current from Q_2 which will become $i+i$ flows here and as a result, the overall emitter current of the differential circuit will be $2i - (i+i) = i-i$. This current is divided the same way as in the differential circuit consisting of Q_{10} and Q_{11} with current $(i-i)/2$ flowing in each of Q_8 and Q_9 . From this, the current of current mirror (3) is determined as $(i-i)/2$ and the current of current mirror (5) becomes $(i+i)/2$.

Now, current $(i-i)/2$ from current mirror (4) flows in transistor Q_{12} of the output stage. Since the current flowing in transistor Q_{13} from current mirror (5) is held at $(i-i)/2$, connecting output resistor R_o between the output pin and the COM pin will result in current i flowing through R_o and providing a voltage signal $V_o = i \cdot R_o$.

Here, by selecting $R_o = 2R_i$, $V_o = i \cdot R_o = 2i \cdot R_i = V_i$ and the amplifier will have a gain of 1.

Next, we will consider case of when control voltage V_c is applied with regard to the selection of this resistance.

6249826 0022327 2T9



DUAL VCA FOR LOW VOLTAGE ELECTRONIC VOLUME CONTROL

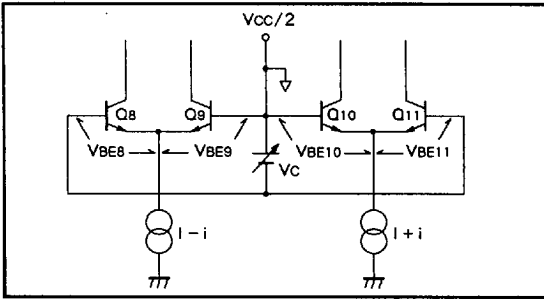

Fig. 2 Differential circuit

The values of V_{BE} of the differential stage will be as follows :

$$V_{BE8} \approx \frac{kT}{q} \ln \left(\frac{I_{C8}}{I_s} \right)$$

$$V_{BE9} \approx \frac{kT}{q} \ln \left(\frac{I_{C9}}{I_s} \right)$$

$$V_{BE10} \approx \frac{kT}{q} \ln \left(\frac{I_{C10}}{I_s} \right)$$

$$V_{BE11} \approx \frac{kT}{q} \ln \left(\frac{I_{C11}}{I_s} \right)$$

where, $\left(\begin{array}{l} I_s : \text{the saturation current} \\ k : \text{the Boltzmann constant} \\ q : \text{the amount of electric charge on the electrons} \\ T : \text{the absolute temperature} \end{array} \right)$

From this,

$$-V_c = V_{BE8} - V_{BE9} = \frac{kT}{q} \ln \frac{I_{C8}}{I_{C9}}$$

$$-V_c = V_{BE11} - V_{BE10} = \frac{kT}{q} \ln \frac{I_{C11}}{I_{C10}}$$

Here

$$I_{C8} + I_{C9} \approx I - i$$

$$I_{C10} + I_{C11} \approx I + i$$

$$-V_c = \frac{kT}{q} \ln \frac{I_{C8}}{I - i - I_{C8}}$$

$$-V_c = \frac{kT}{q} \ln \frac{I_{C11}}{I + i - I_{C11}}$$

The current flowing through Q_8 and Q_{11} will be

$$I_{C8} = \frac{(I - i) \exp\left(-\frac{q}{kT} V_c\right)}{1 + \exp\left(-\frac{q}{kT} V_c\right)} = \frac{I - i}{1 + \exp\left(\frac{q}{kT} V_c\right)}$$

$$I_{C11} = \frac{(I + i) \exp\left(-\frac{q}{kT} V_c\right)}{1 + \exp\left(-\frac{q}{kT} V_c\right)} = \frac{I - i}{1 + \exp\left(\frac{q}{kT} V_c\right)}$$

Current I_{C11} is the current of current mirror (4), and I_{C8} will be the same as the current of current mirror (5).

At this time, the current that will flow through the output pin will be the same as that in the explanation when V_c was equal to zero, and is expressed as

$$i_o = \frac{2i}{1 + \exp\left(\frac{q}{kT} \cdot V_c\right)}$$

The gain will be

$$\frac{V_o}{V_i} = \frac{i_o \cdot R_o}{2i \cdot R_i} = \frac{2}{1 + \exp\left(\frac{q}{kT} \cdot V_c\right)}$$

and when calculated in dB,

$$ATT = 20 \log \left(\frac{2}{1 + \exp\left(\frac{q}{kT} \cdot V_c\right)} \right)$$

As in the graph below, the attenuation will change logarithmically with respect to the change of V_c .

ATTENUATION VS. CONTROL VOLTAGE

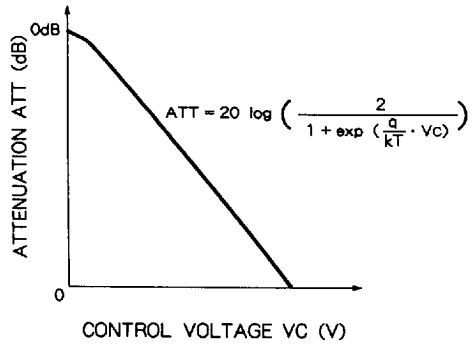

Setting and connection of input/output resistance

As explained above, the input signal is converted to current, but since the transistor of the input stage is biased at a fixed current of $I = 76 \mu A$, the maximum value of the input current is determined at the least upper bound of I (Fig.3). Accordingly, when a large signal is input it is necessary to select a large input/output resistance and decrease the input current. Note that increasing the resistance will also increase the noise distortion factor, so the value of the setting should be made to suit the particular application.

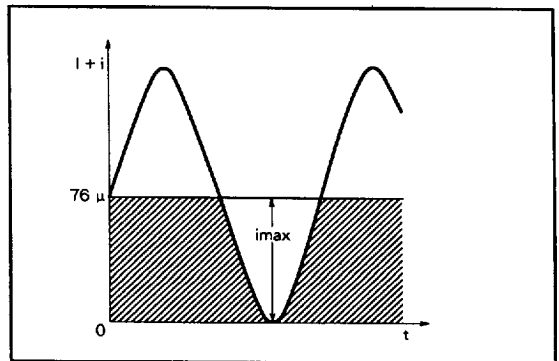

Fig. 3 Maximum current signal

6249826 0022328 135



DUAL VCA FOR LOW VOLTAGE ELECTRONIC VOLUME CONTROL

The M5222 has a floating-type output stage with the collectors of Q12 and Q13 joined as shown in FIG. 4. Here, the difference of the combined currents will become the output current that will flow through the load. Note that it is necessary to set the DC potential of this output pin by externally-connected resistor R_o and that it is generally DC-connected to the $V_{cc}/2$ pin (or to pin (3)).

In terms of AC, it is necessary to set the output pin to ground level so that capacitor C is required. Since the voltage gain (amount of attenuation) is determined by R_o , the value of the input impedance connected to the next stage is sometimes affected. (Placing Z_i in parallel with R_o will lower the impedance.) Generally, a buffer amplifier composed of a transistor or OP amp connected.

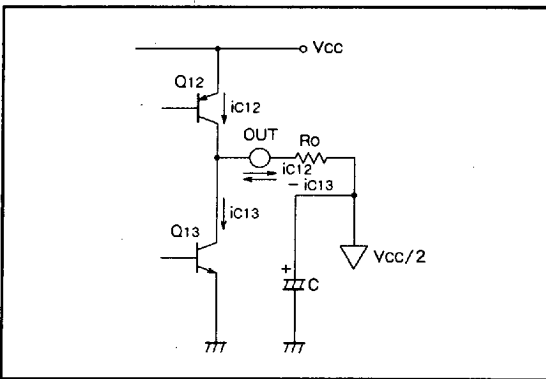

Fig. 4 Equivalent circuit of output stage

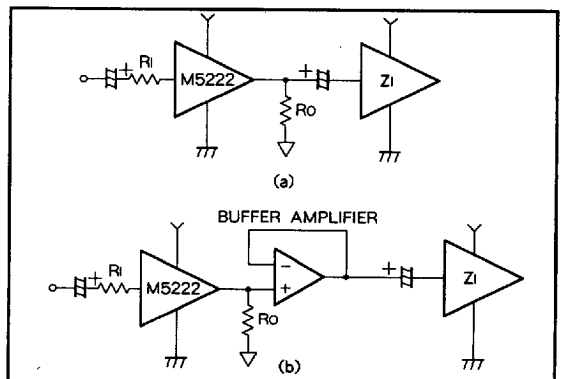
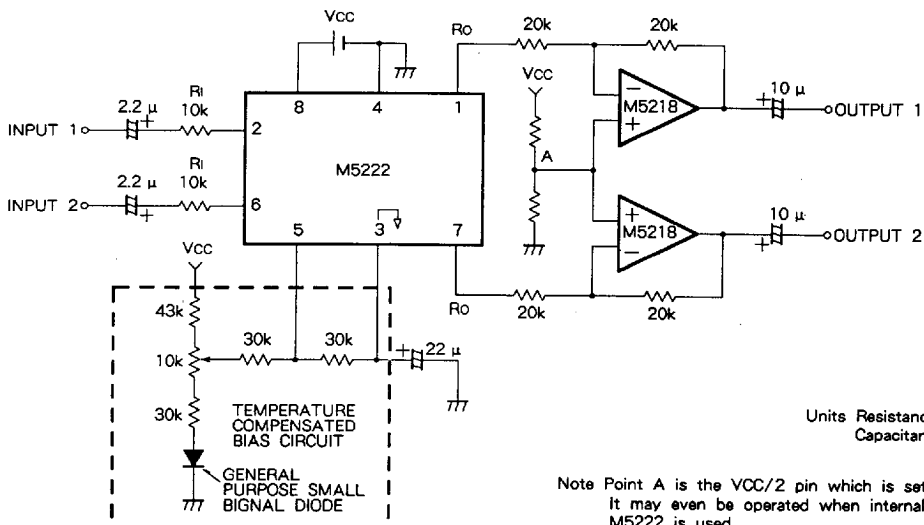

Fig. 5 Connection example

APPLICATION EXAMPLES

(1) TEMPERATURE COMPENSATED BIAS AND OUTPUT BUFFER CIRCUITS



Units Resistance : Ω
Capacitance : F

Note Point A is the $V_{cc}/2$ pin which is set externally. It may even be operated when internal pin 3 of M5222 is used.

6249826 0022329 071



M5222L/P/FP

DUAL VCA FOR LOW VOLTAGE ELECTRONIC VOLUME CONTROL

(2) PROGRAMMABLE ATTENUATION CIRCUIT

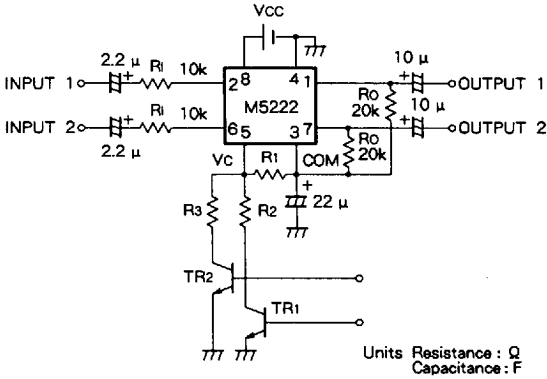

ATTENUATION VS. AMBIENT TEMPERATURE
(TEMPERATURE COMPENSATION)

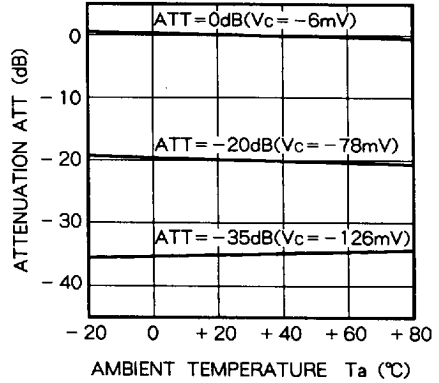

(3) CONTROL APPLICATION WITH EXISTING VOLTAGE CONTROL

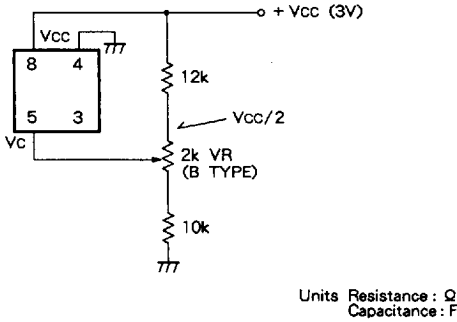

PRINTED CIRCUIT BOARD FOR CIRCUIT TESTING

PRINTED CIRCUIT BOARD WIRING DIAGRAM (COPPER FOIL SIDE)

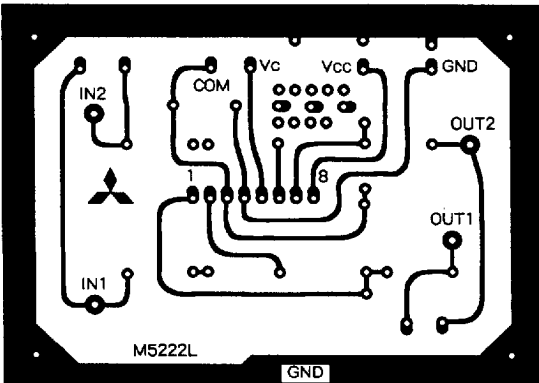

(PARTS SIDE)

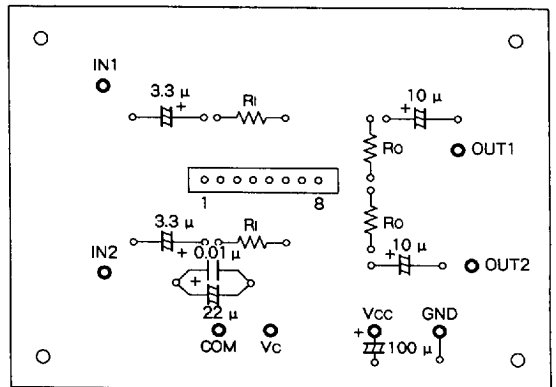

6249826 0022330 893

