

# M5229P/FP

## Hi-Fi 7-ELEMENT GRAPHIC EQUALIZER IC

### DESCRIPTION

The M5229 is a 7-element graphic equalizer IC best suited to Hi-Fi audio systems. It has 7-element resonance circuits with OP amp system and an output OP amp.

The IC can be used in compact sets of high-density assemblies, modules, and hybrid ICs. Its applications cover Hi-Fi stereo sets, radio cassette tape players, car audio systems, music centers, and electronic instruments.

### FEATURES

- High withstand voltage and wide supply voltage range  
.....  $V_{CC} = \pm 2$  to  $\pm 18V$  (4 to 36V)
- Low distortion ..... THD = 0.002% (typ)  
(@  $f = 1kHz$ , Flat,  $V_o = 5V_{rms}$ )
- Low noise .....  $V_{No} = 9 \mu V_{rms}$  (typ)  
(@ Flat, input short)
- Variable  $G_v$  by external resistance .....  $G_v = \pm 12dB$  (typ)
- Single power (use GND pin  $\oplus$  for  $V_{CC}/2$  pin)
- Large allowable input voltage .....  $V_{iM} = 9.5V_{rms}$  (typ)  
(@  $f = 1kHz$ , THD = 1%, Flat)

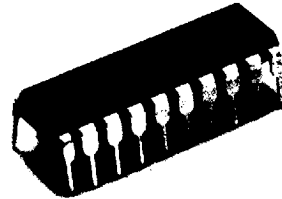

Outline 20P4(P)  
2.54mm pitch 300mil DIP  
(6.3mm x 24.0mm x 3.3mm)

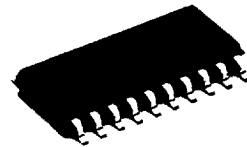

Outline 20P2N-A(FP)  
1.27mm pitch 300mil SOP  
(5.3mm x 12.6mm x 1.8mm)

### RECOMMENDED OPERATING CONDITIONS

- Supply voltage range .....  $V_{CC}, V_{EE} = \pm 2$  to  $\pm 18V$   
or  $V_{CC} = 4$  to 36V
- Rated supply voltage .....  $V_{CC}, V_{EE} = \pm 15V$  or  $V_{CC} = 30V$
- Rated power dissipation ..... 1000mW(DIP)  
550mW(FP)

### SYSTEM CONFIGURATION

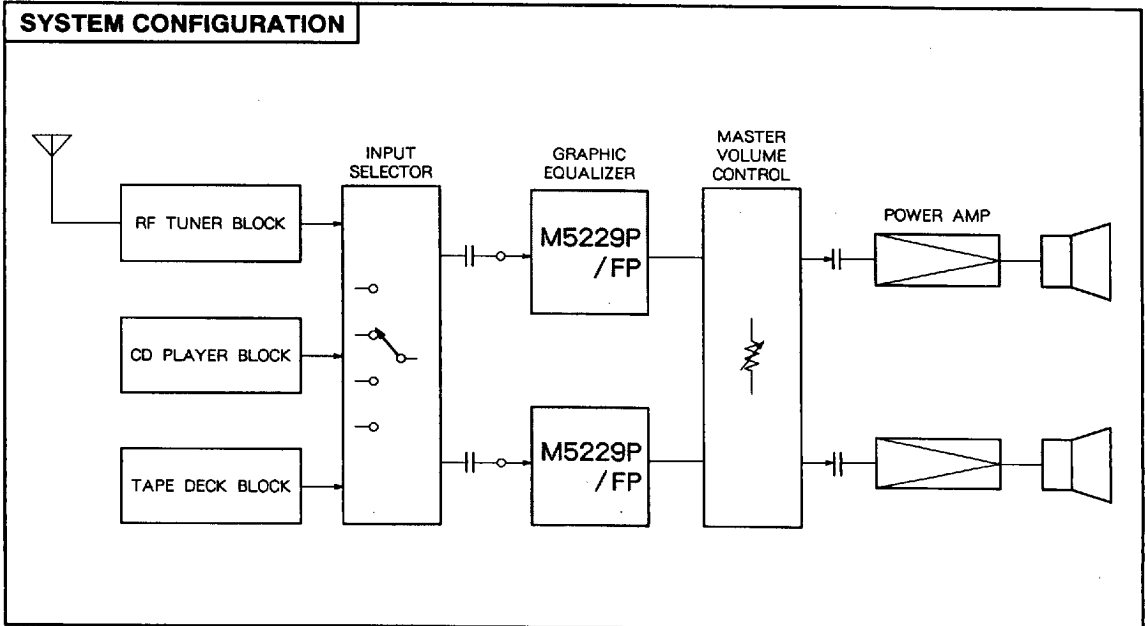

6249826 0022439 9T1



M5229P/FP

HI-FI 7-ELEMENT GRAPHIC EQUALIZER IC

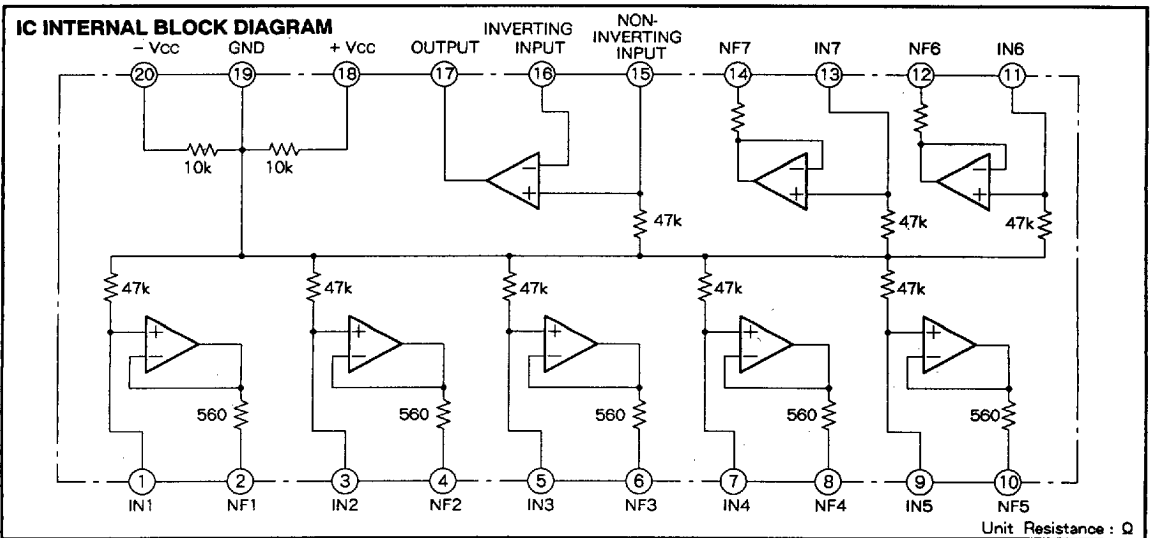
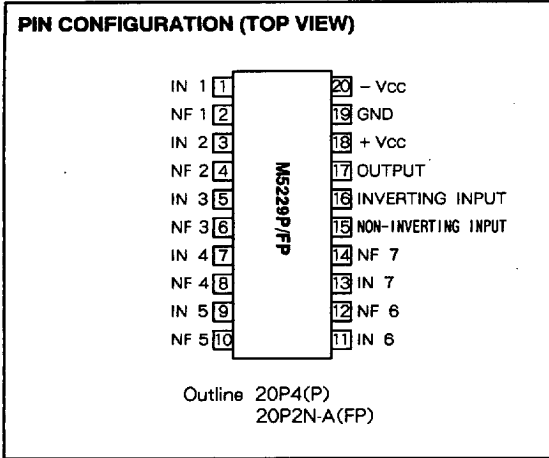

6249826 0022440 6J3



**ABSOLUTE MAXIMUM RATINGS** (Ta = 25 °C, unless otherwise noted)

Symbol	Parameter	Ratings	Unit
Vcc	Supply voltage	36 (± 18)	V
ILP	Load current	50	mA
Pd	Power dissipation	1000(P)/550(FP)	mW
Topr	Operating temperature	- 20 to + 75	°C
Tstg	Storage temperature	- 55 to + 125	°C

**ELECTRICAL CHARACTERISTICS** (Ta = 25 °C, Vcc = ± 15V)

Symbol	Parameter		f [Hz]	Test conditions	Limit			Unit
					Min	Typ	Max	
Icc	Circuit current		-	Vin = 0	8	12	16	mA
Gv (FLAT)	Voltage Gain	Flat	1k	Vin = - 10dBm Vo (FLAT) = 0dB	- 2.3	- 0.3	+ 1.7	dB
Gv(BOOST)			Boost (Response)		60	9.0	12.0	
		120			9.0	12.0	14.0	
		360			9.0	12.0	14.0	
		1k			9.0	12.0	14.0	
		2.5k			9.0	12.0	14.0	
		6.7k			9.0	12.0	14.0	
Gv (CUT)		Cut (Response)	15.7k		9.0	12.0	14.0	
			60		- 14.0	- 12.0	- 9.0	
			120		- 14.0	- 12.0	- 9.0	
			360		- 14.0	- 12.0	- 9.0	
			1k		- 14.0	- 12.0	- 9.0	
			2.5k		- 14.0	- 12.0	- 9.0	
Vom		Maximum output voltage			1k	THD = 1 %, Flat	7	9.5
	THD		1k	Vo = 5Vrms, Flat	-	0.002	0.1	%
Vno	Output noise voltage		Input short BM : 10Hz to 30kHz, Flat		-	9	35	µVrms

**TYPICAL CHARACTERISTICS**

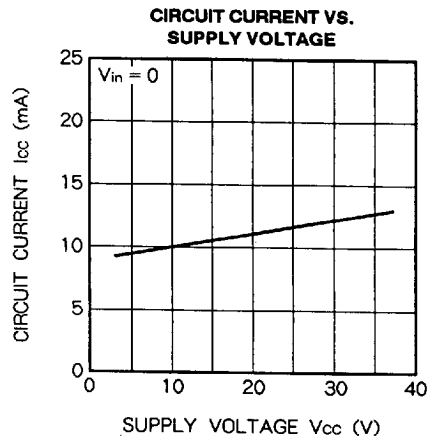
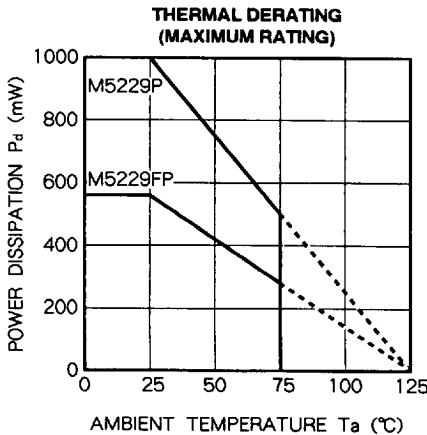

6249826 0022441 55T



# M5229P/FP

## HI-FI 7-ELEMENT GRAPHIC EQUALIZER IC

### APPLICATION EXAMPLE (STANDARD)

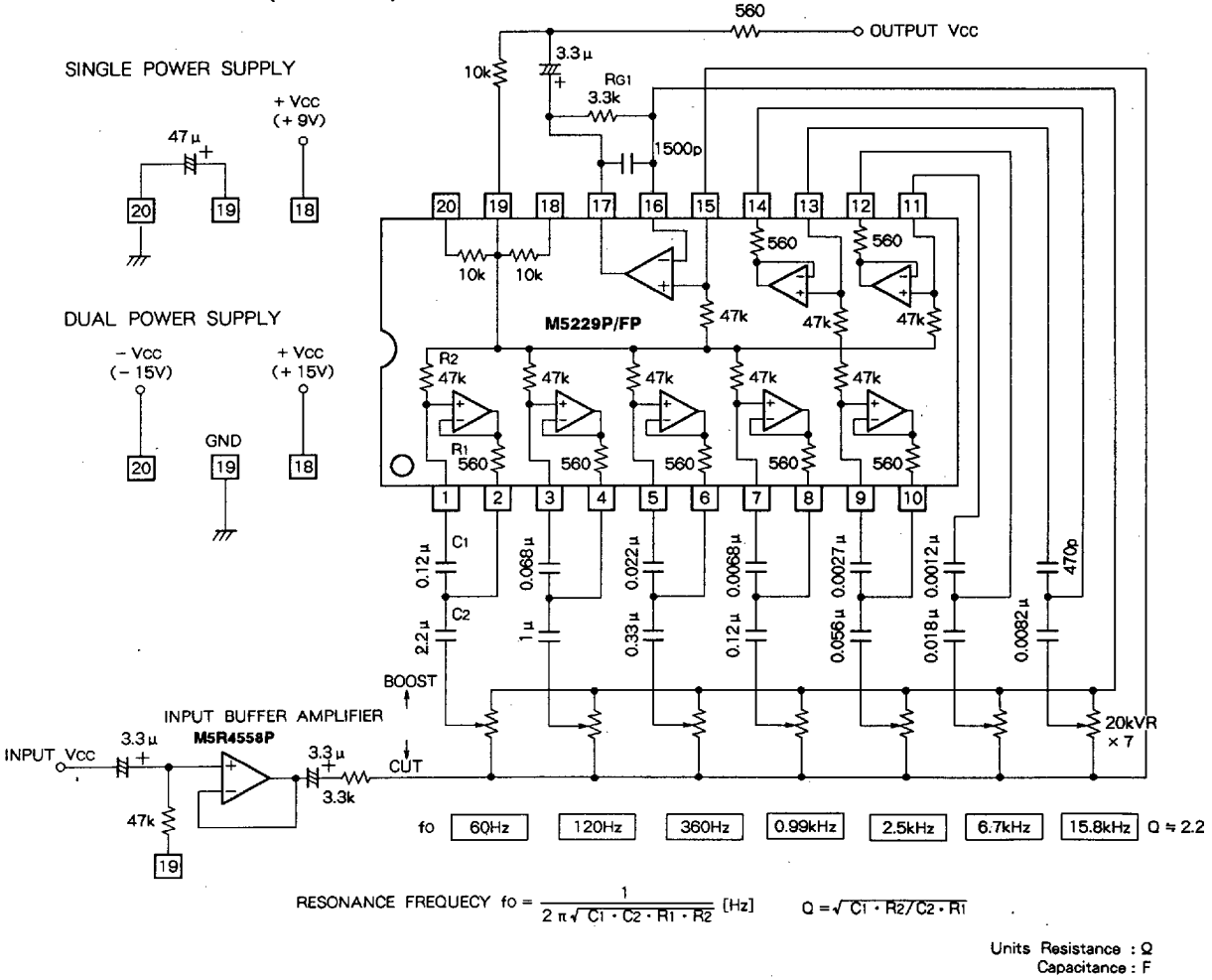

6249826 0022442 496



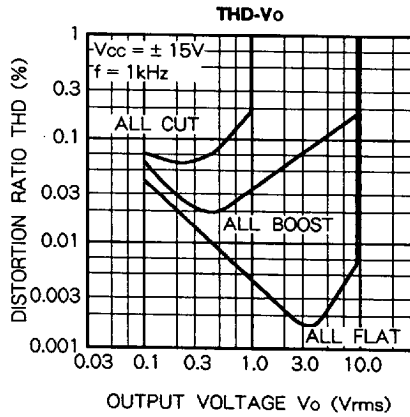
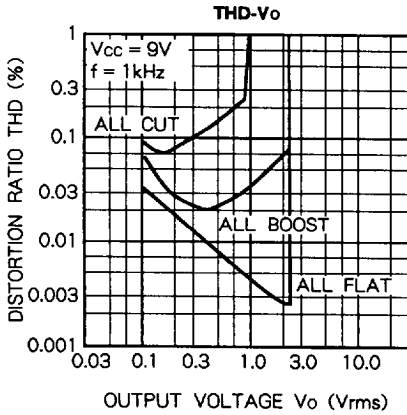
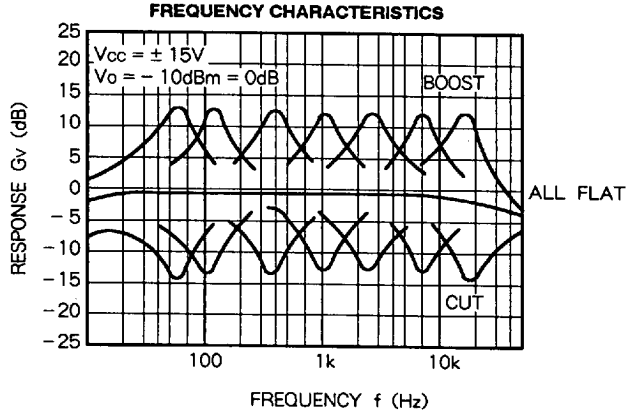

6249826 0022443 322



**OPERATION DESCRIPTION**

The M5229 consists of 7 resonance circuits and an output amplifier, and can also form a graphic equalizer, which has optional resonance frequency,  $f_0$ , by the externally connecting condenser  $C_1$ ,  $C_2$  of variable resistance and a resonance circuit. The impedance is minimized by resonating and the semiconductor inductor, which is adopted in the resonance circuit, can therefore vary the frequency gain.

**1. Flat boost cut**

The resonance frequency gain can be altered by varying the external variable register.

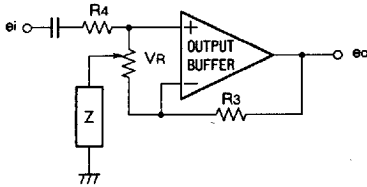

Z is an impedance in the resonance circuit

**(1) Flat**

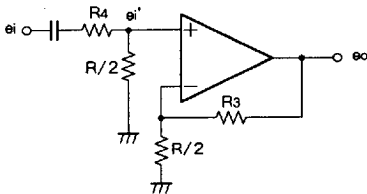

R/2 is resistance at the center of VR

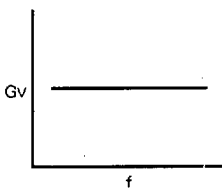

When the variable register is in center position, the equivalent circuit as in the above diagram can be obtained. At this stage if  $R_3$ ,  $R_4$  are set at the same level of resistance, then

$$e_i' = \frac{R/2}{R_4 + R/2} \cdot e_i, \quad A_v = \frac{R_3 + R/2}{R/2}$$

$$e_o = A_v \cdot e_i' = e_i$$

and, the frequency characteristics will be level regardless of the resonance circuit.

**(2) Boost**

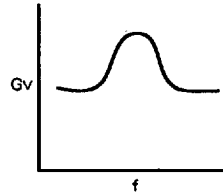
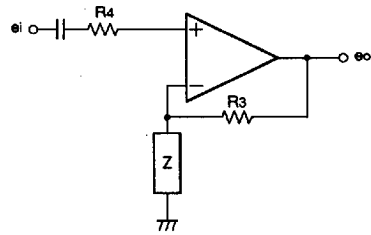

When the variable register is in boost position, the resonance circuit is connected to the NF loop of the output buffer amplifier. At this stage, R is much smaller than  $R_3$ ,  $R_4$ , so it can be disregarded.

The gain  $A_v$  is  $A_v = \frac{R_3 + Z}{Z}$  and,

$$\text{the output voltage } e_o \text{ is } e_o = A_v \cdot e_i = \frac{R_3 + Z}{Z} \cdot e_i$$

When Z is smallest, the gain in resonance is the greatest, and the optional frequency is then boosted.

**(3) Cut**

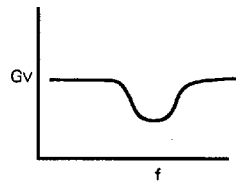
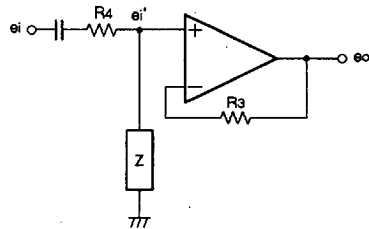

HI-FI 7-ELEMENT GRAPHIC EQUALIZER IC

When the variable register is in cut position, the resonance circuit is connected to the input side of the output buffer amplifier. When R is disregarded as the boost,

$$e_i' = \frac{Z}{R_4 + Z} \cdot e_i \cdot Av = 1 \text{ and,}$$

$$\text{the output voltage } e_o \text{ is } e_o = Av \cdot e_i' = \frac{Z}{R_4 + Z} \cdot e_i$$

When Z is smallest, the gain in resonance is the greatest, and the optional frequency is then cut.

**2. Resonance circuit**

The semiconductor inductor converts L in the R, L, C serial resonance circuit into a CR pin by the buffer functions of active pins such as registers, Operational amplifiers, and works in a almost the same way as the R, L, C serial resonance circuit.

The R, L, C resonance frequency fo is

$$f_o = 1/2 \pi \sqrt{LC} \dots\dots\dots \text{Equation No.1}$$

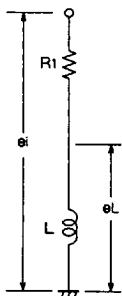

Fig. 1



Fig. 2

When the voltage ei is supplied to the resonance circuit as shown in Fig. 1.

$$e_L = j\omega L \cdot e_i / (R_1 + j\omega L)$$

If ei is then supplied to the pins C1, R2 as shown in Fig.2,

$$e_R = e_i \cdot j\omega C_1 \cdot R_2 / C_1 + j\omega C_1 \cdot R_2$$

$$= j\omega C_1 \cdot R_1 \cdot R_2 / CR_1 + j\omega C_1 \cdot R_1 \cdot R_2$$

$$\text{When } e_L = e_R, L = C_1 \cdot R_1 \cdot R_2 \dots\dots \text{Equation No.2}$$

But if eR is replaced by L of the R and L serial circuit, R1 and C1 are automatically connected in a parallel manner, and the value of eR will be changed. So, in order to keep the value of eR stable, a buffer amplifier should be used. The buffer amplifier is equivalent to an impedance.

By equations 1 and 2, the resonance frequency, fo is

$$f_o = 1/2 \pi \sqrt{C_1 \cdot C_2 \cdot R_1 \cdot R_2}$$

The buffer amplifier in the resonance circuit of the M5229 is composed of operational amplifiers.

**3. Angle of maximum resonance**

The angle of maximum resonance, Q, is defined by the ratio of  $\omega_0$  ( $\omega_0 = 2 f_o$ ) and the frequency band width,  $\omega_2 - \omega_1$ , ( $G_{max}/\sqrt{2}$ )

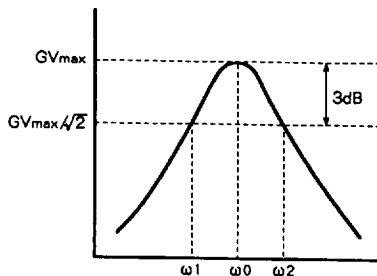

The value of Q is found by the following equation ;

$$Q = \sqrt{C_1 \cdot R_2 / C_2 \cdot R_1}$$

The greater the value of Q, the narrower the frequency band width, and vice versa.

The M5229 is composed of R1, R2, so Q is defined by selecting the external condensor.

6249826 0022445 1T5

