

M5265P

LOW SATURATION OUTPUT TYPE CURRENT DRIVER

DESCRIPTION

M5265P is quad Darlington current driver (semiconductor integrated circuit) which consists of PNP and NPN transistors with clamp diode and it can be driven directly by very small input current.

Low saturation output can be obtained by separating the output stage transistor's collector from the drive stage transistors.

CHARACTERISTICS

- High voltage resistance $BV_{CEO} \geq 80V$
- High input voltage resistance $V_I \geq 20V$
- Large current drive $I_{C(max)} = 2.0A^*$
- Low saturation output $0.25V$ (typ) ($I_C = 0.3A$)
- Contains a clamp diode.
- Operates by the "L" level input.
- Wide operating temperature range . . $T_a = -40^\circ C \sim +85^\circ C$
* PW = 10 ms, duty cycle $\leq 10\%$

APPLICATION

Motor drives for various relays or portable printers, digit drives for display elements such as LEDs and lamps, or power amplifiers

FUNCTION

Unlike the existing common-collector-type transistor arrays, M5265P realizes 0.25V of low saturation output voltage (typ, $I_C = 0.3A$) by separating the drive stage collector from the output stage collector. Therefore, the power dissipation which is determined by the product of the load current and the saturation output voltage can be greatly decreased.

The maximum output current is 2.0A and up to 80V can be applied as the output voltage.

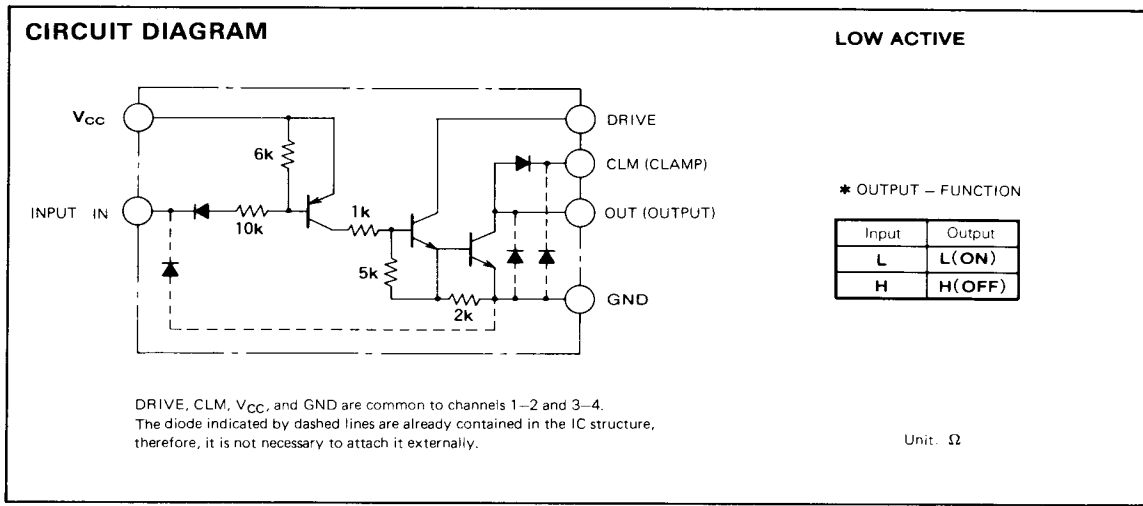
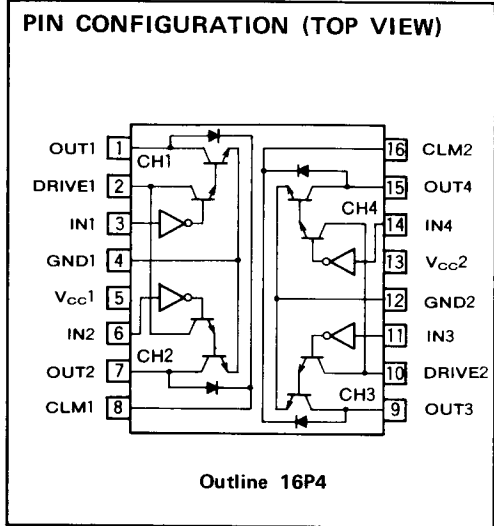

LOW SATURATION OUTPUT TYPE CURRENT DRIVER

ABSOLUTE MAXIMUM RATINGS (Ta = 25°C, unless otherwise noted)

Symbol	Parameter	Conditions	Rating	Unit
V _{CC}	Supply voltage		20	V
V _D	Drive stage applied voltage		80	V
V _{CE(D)}	Output voltage	When the output is "H"	80	V
V _I	Input voltage	V _{CC} = 5V	30	V
I _C	Output current	Current per circuit when the output is "L"	2.0*	A
V _R	Clamp diode reverse voltage		80	V
I _F	Clamp diode forward current		2.0	A
P _d	Power dissipation	Ta = 25°C	2.0(2.5)**	W
T _{opr}	Operating temperature		-40 ~ +85	°C
T _{stg}	Storage temperature		-55 ~ +150	°C

* : PW = 10ms, duty cycle ≤ 10%
 ** : 400mm² of copper film is added.

RECOMMENDED OPERATING CONDITIONS (Ta = 25°C, unless otherwise noted)

Symbol	Parameter	Condition	Limits			Unit
			Min	Typ	Max	
V _{CC}	Supply voltage		4	5	6	V
V _D	Drive stage applied voltage		4	5	70	V
V _{CE}	Output applied voltage		0		70	V
I _C	Output current	Current per circuit	0	0.3	1.25	A
V _R	Clamp diode reverse voltage		0		70	V
I _F	Clamp diode forward current		0		1.25	A
P _d	Operating temperature		0		1.0	W

ELECTRICAL CHARACTERISTICS (Ta = 25°C, value/circuit unless otherwise noted)

Symbol	Parameter	Test conditions	Limits			Unit	
			Min	Typ	Max		
V _{(BR)CEO}	Output breakdown voltage	I _{CEO} = 100 μA	80			V	
I _{OCH}	Output "H" supply current	V _{CC} = 6V, V _I = V _{CC}			10	μA	
I _{OCL}	Output "L" supply current	V _{CC} = 6V, V _I = 0, 5V			10	mA	
V _{CE(sat)}	Saturation output voltage	V _{CC} = 4V V _D = 4V V _I = 0.5V		I _C = 1.25A, R _D = 50 Ω I _C = 0.7A, R _D = 100 Ω I _C = 0.3A, R _D = 260 Ω	1.0 1.0 0.5	1.8 1.0 0.5	V
I _I	Input current	V _I = V _{CC} - 0.5V V _I = V _{CC} - 6V			-0.1 -0.1	mA	
I _{O(leak)}	Output lead current	V _{CE} = 80V			100	μA	
I _R	Clamp diode leak current	V _R = 80V			50	μA	
V _R	Clamp diode reverse voltage	I _R = 100 μA	80			V	
V _F	Clamp diode forward voltage	I _F = 1.25A			2.5	V	
V _{I(H)}	"H" input voltage	I _{O(leak)} = 50 μA	V _{CC} - 1.0			V	
V _{I(L)}	"L" input voltage	I _C = 1.25A			V _{CC} - 3.5	V	

TIMING DIAGRAM

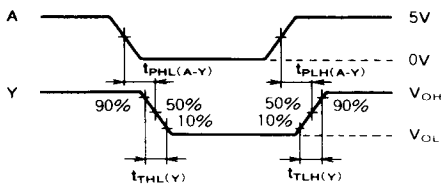

TYPICAL SPEED (Example)

t _{PHL(A-Y)}	t _{PLH(A-Y)}	t _{THL(Y)}	t _{TLH(Y)}
140ns	8.0 μs	100ns	650ns



LOW SATURATION OUTPUT TYPE CURRENT DRIVER

TEST CIRCUITS

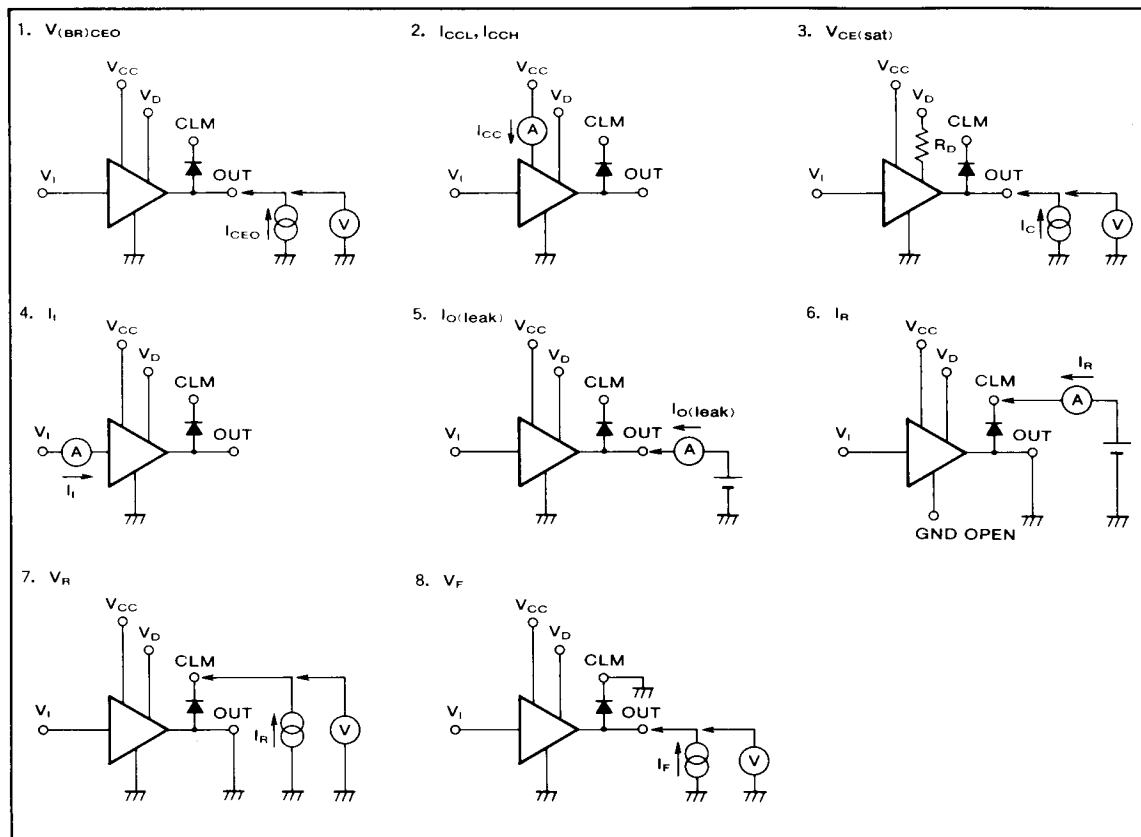

TYPICAL CHARACTERISTICS

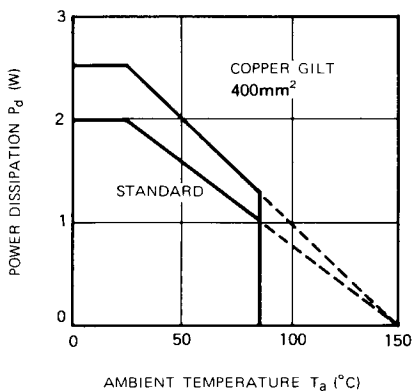

SAMPLE PCB LAYOUT

When you design a layout of a PCB, you have to consider the thermal derating. To improve the heat radiation of an IC, add a 400 mm² of copper film at the base of the GND pin. This will improve the thermal derating characteristics.

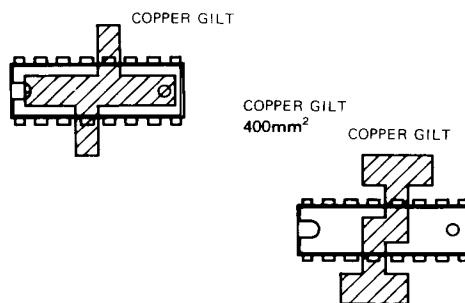

LOW SATURATION OUTPUT TYPE CURRENT DRIVER

SATURATION OUTPUT VOLTAGE VS. DRIVE STAGE RESISTANCE

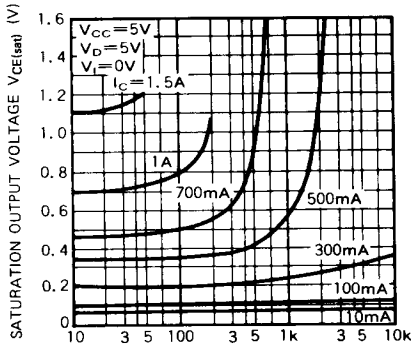

DRIVE STAGE RESISTANCE R_D (Ω)

DRIVE STAGE VIAS VOLTAGE VS. DRIVE STAGE RESISTANCE

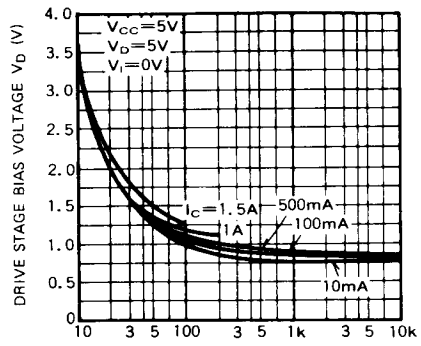

DRIVE STAGE RESISTANCE R_D (Ω)

SATURATION OUTPUT VOLTAGE VS. OUTPUT CURRENT

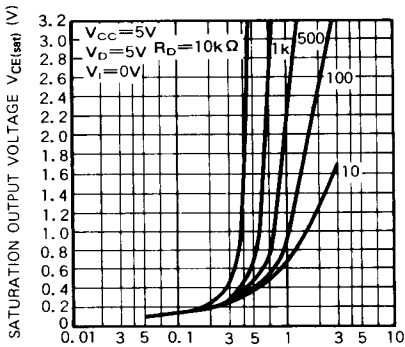

OUTPUT CURRENT I_C (A)

CLAMP DIODE FORWARD CURRENT VS. CLAMP DIODE FORWARD VOLTAGE

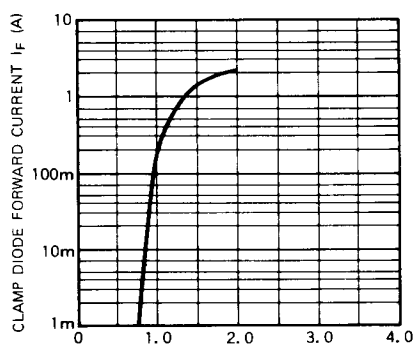

CLAMP DIODE FORWARD VOLTAGE V_F (V)

CIRCUIT CURRENT VS. SUPPLY VOLTAGE

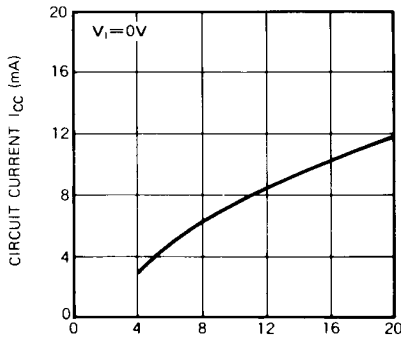

SUPPLY VOLTAGE V_{CC} (V)

OUTPUT VOLTAGE VS. INPUT VOLTAGE

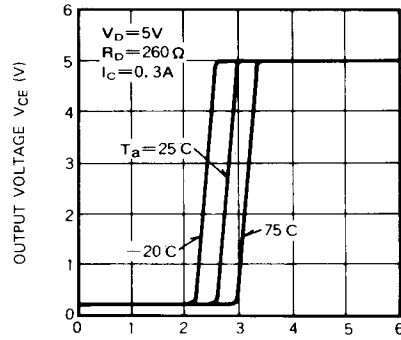

INPUT VOLTAGE V_i (V)



LOW SATURATION OUTPUT TYPE CURRENT DRIVER

INPUT CURRENT VS. AMBIENT TEMPERATURE

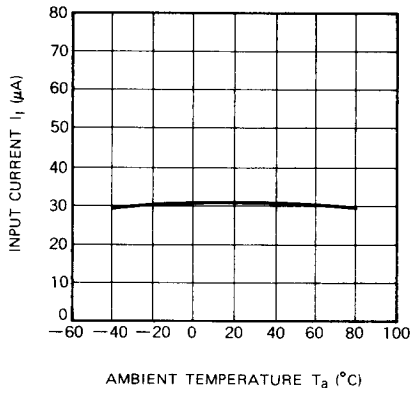

SATURATION OUTPUT VOLTAGE VS. AMBIENT TEMPERATURE

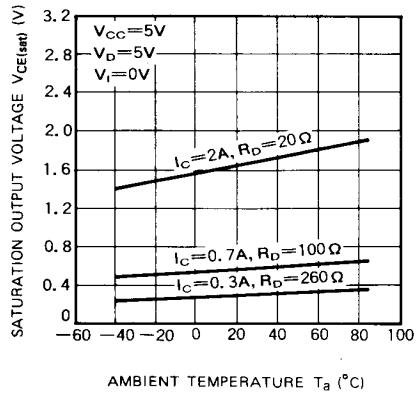

APPLICATION CIRCUIT (Stepping motor drive for a printer)

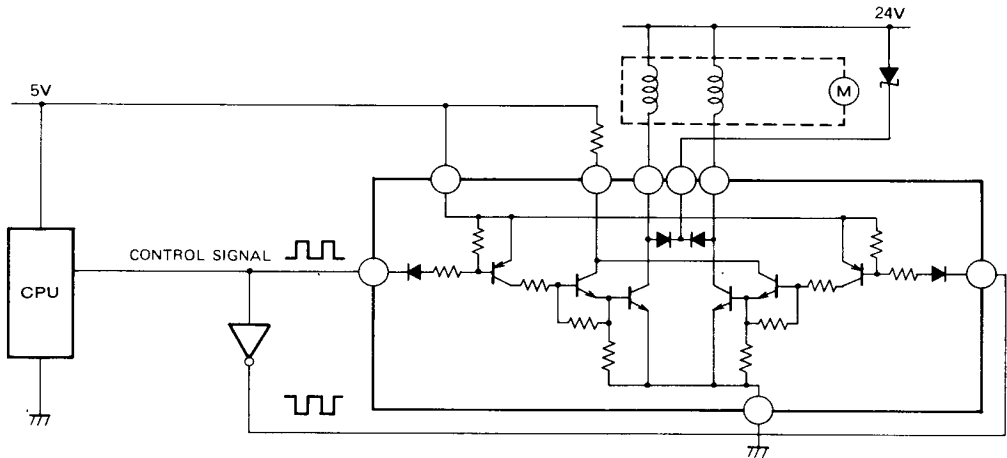

V_{CC} , DRIVE, CLAMP, AND GND ARE THE SAME FOR BOTH CIRCUITS.