

M5289P/FP

Hi-Fi 7-ELEMENT GRAPHIC EQUALIZER IC

DESCRIPTION

The M5289 is a 7-element graphic equalizer IC best suited to Hi-Fi audio systems. It has a built-in 7-element of transistor-based resonance circuits and an output OP amp. The IC can be used in compact sets of high-density assemblies, modules, and hybrid ICs. Its applications cover Hi-Fi stereo sets, portable radio cassette tape players, car audio systems, music centers, and electronic instruments.

FEATURES

- Low distortion
 THD = 0.001 % (M5289P), 0.003 % (M5289FP) (typ)
 (@ f = 1kHz, Flat)
- Low noise V_{no} Flat = $3.5 \mu V_{rms}$ (typ)
 High pressure proof ($V_{cc} = \pm 15V$)
- Dynamic range is large $V_{om} = 9.2V_{rms}$ (M5289P),
 $2.0V_{rms}$ (M5289FP) (typ)
- Capable of being driven by single power supply single
 power (use GND pin ⑩ for $V_{cc}/2$ pin)
- Variable G_v by external resistance

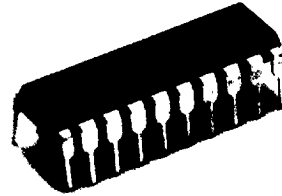

Outline 20P4(P)
 2.54mm pitch 300mil DIP
 (6.3mm × 24.0mm × 3.3mm)

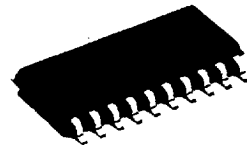

Outline 20P2N-A(FP)
 1.27mm pitch 300mil SOP
 (5.3mm × 12.6mm × 1.8mm)

RECOMMENDED OPERATING CONDITIONS

Supply voltage range... $V_{cc}, V_{EE} = \pm 2$ to $\pm 15V$ (4 to 30V)
 Rated supply voltage $V_{cc}, V_{EE} = \pm 15V$
 Rated power dissipation 1000mW(P)
 550mW(FP)

SYSTEM CONFIGURATION

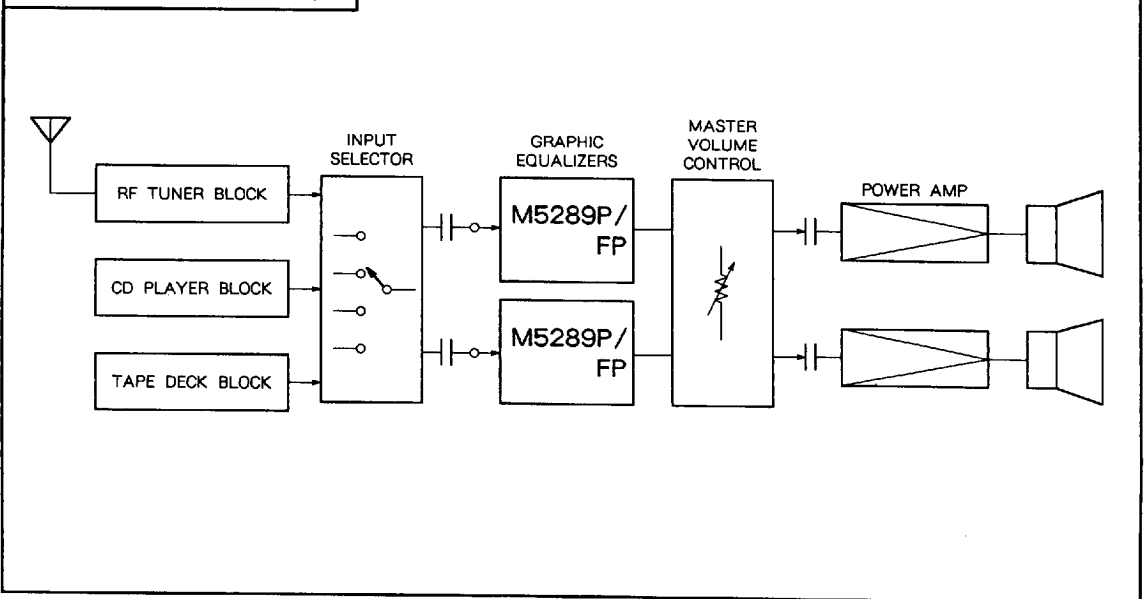

6249826 0022455 044



PIN CONFIGURATION (TOP VIEW)

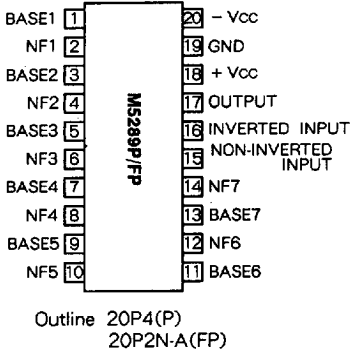

IC INTERNAL BLOCK DIAGRAM

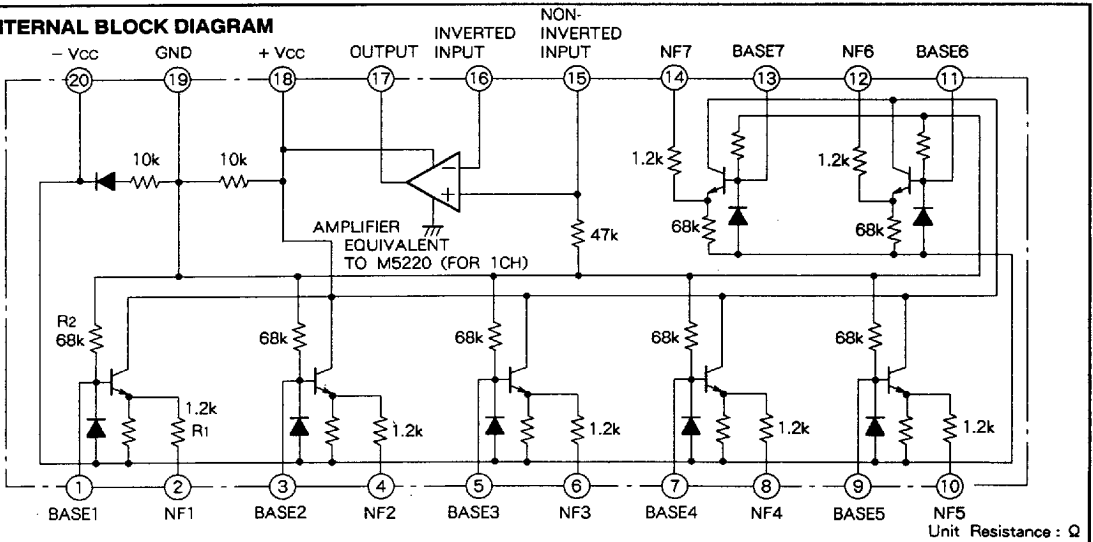

6249826 0022456 T80



ABSOLUTE MAXIMUM RATING (Ta = 25 °C, unless otherwise noted)

Symbol	Parameter	Rating	Unit
Vcc	Supply voltage	36 (± 18)	V
I _{LP}	Load current	50	mA
P _d	Power dissipation	1000(P)/550(FP)	mW
T _{opr}	Operating temperature	- 20 to + 75	°C
T _{stg}	Storage temperature	- 55 to + 125	°C

ELECTRICAL CHARACTERISTICS (Ta = 25 °C, Vcc = ± 15V (M5289P), + 9V (M5289FP), unless otherwise noted)

Symbol	Parameter	Test conditions	f = [Hz]	Limits			Unit	
				Min	Typ	Max		
I _{cc}	Circuit current	V _{in} = 0	Vcc = + 9V Vcc = ± 15V	-	4.4 11.3	6.8 17.8	10.5 24.5	mA
G _v (FLAT)	Voltage gain	Flat	V _{in} = - 10dBm	1k	- 3.0	- 0.5	+ 1.8	dB
G _v (BOOST)				Boost	V _{in} = - 10dBm V _o (FLAT) = 0dB	61.7	7.5	10.5
		156	7.5			10.5	13.1	
		412	7.5			10.5	13.1	
		1.08k	7.5			10.5	13.1	
		2.29k	7.5			10.5	13.1	
		6.17k	7.5			10.5	13.1	
G _v (CUT)		Cut	V _{in} = - 10dBm V _o (FLAT) = 0dB	15.6k	7.5	10.5	13.1	dB
				61.7	- 13.1	- 10.5	- 7.5	
				156	- 13.1	- 10.5	- 7.5	
	412			- 13.1	- 10.5	- 7.5		
V _{OM}	Maximum output voltage	THD = 1 %	M5289P M5289FP	1k	6.7	9.2	-	V _{rms}
					1.2	2.2	-	
THD	Total harmonic distortion	V _o = 1V _{rms}	M5289P M5289FP	1k	-	0.001	0.05	%
V _{NO}	Output noise voltage	Input short BM : 10Hz to 30kHz flat		-	-	3.5	13.0	μ V _{rms}

* Single power source Vcc = + 9V is standard for M5289FP because the power dissipation is limited to 550mW.

TYPICAL CHARACTERISTICS

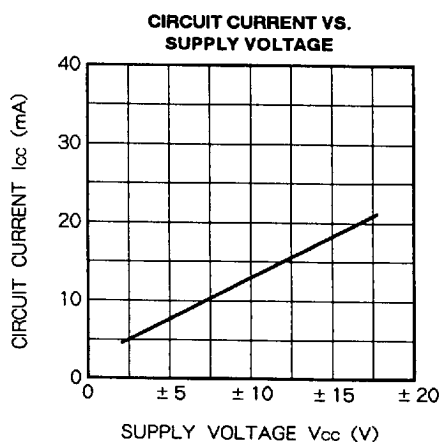
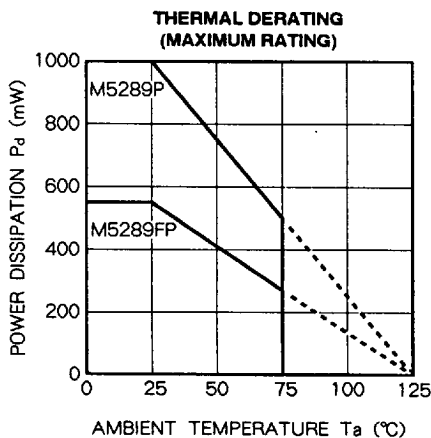

6249826 0022457 917



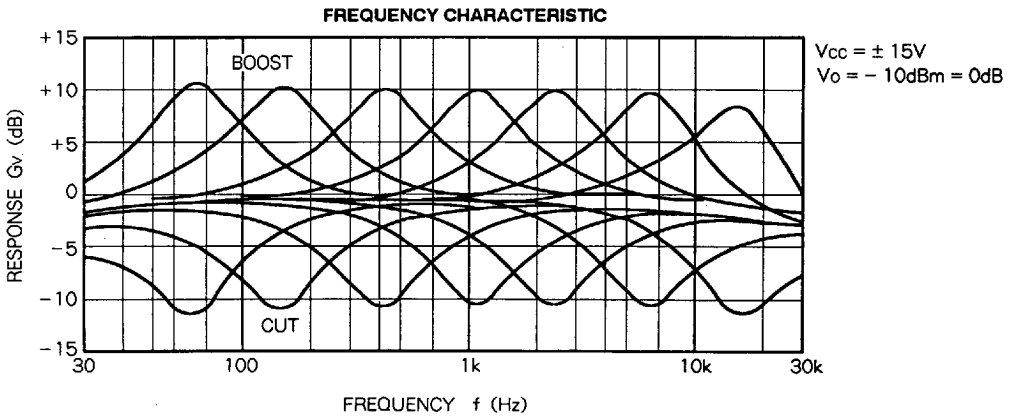
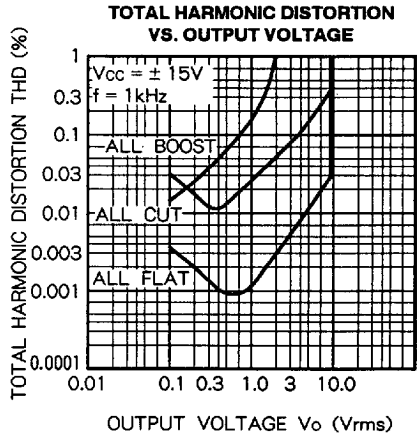
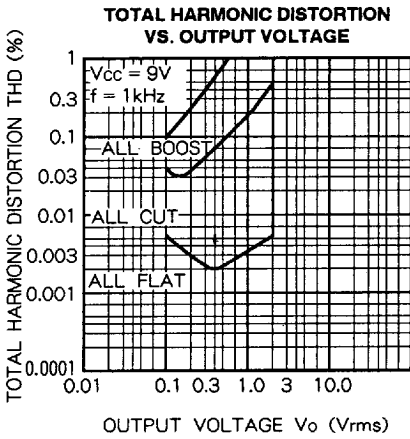
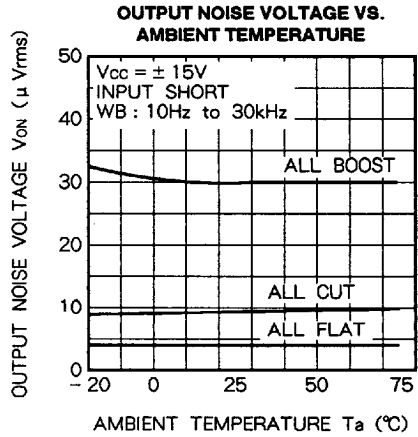
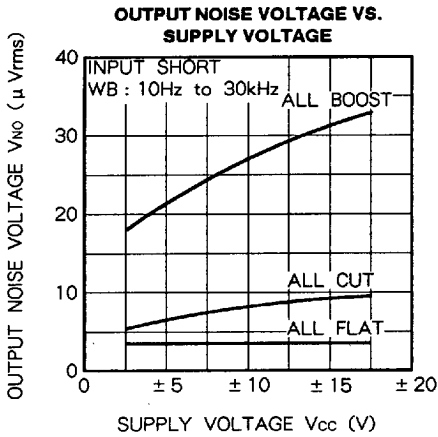

6249826 0022458 853



APPLICATION EXAMPLE

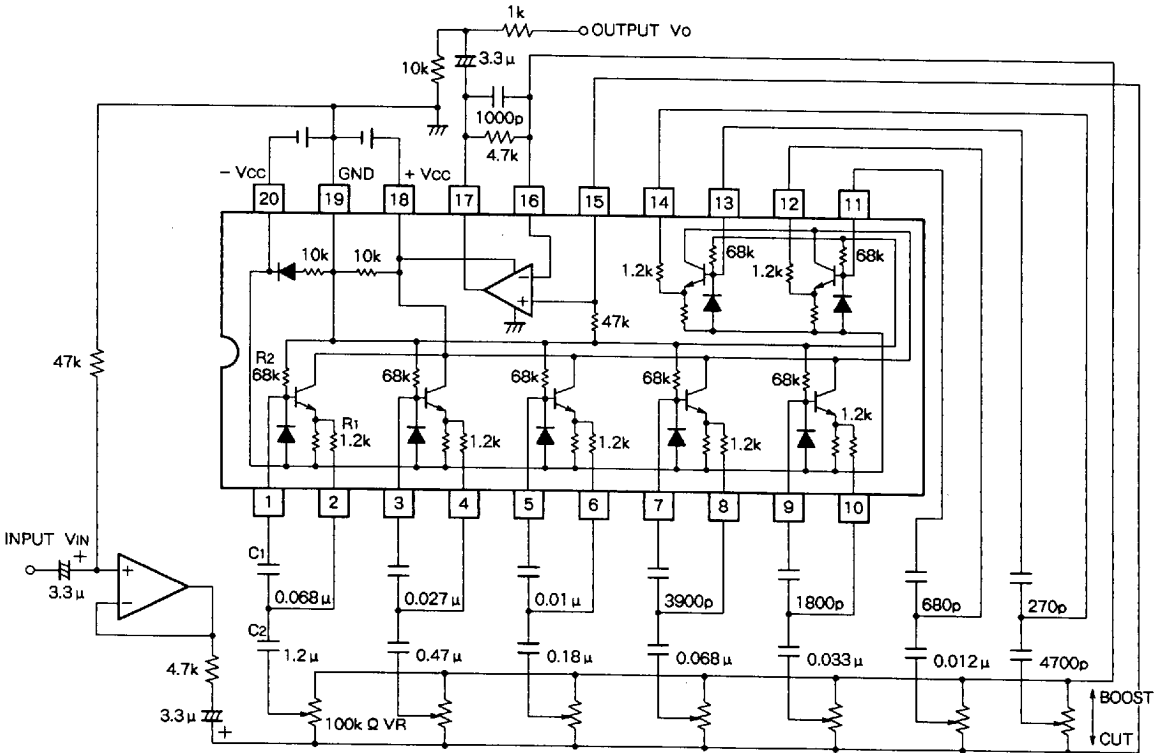

fo = 61.7Hz 156Hz 412Hz 1.08kHz 2.29kHz 6.17kHz 15.6kHz

$$\text{RESONANCE FREQUENCY } f_o = \frac{1}{2\pi\sqrt{C_1 \cdot C_2 \cdot R_1 \cdot R_2}} \text{ (Hz)}$$

Units Resistance : Ω
Capacitance : F

1. M5289FP

Maximum rating of power dissipation P_d for M5289FP is 550mW. We recommend that you take notice of thermal deration well for your application.

6249826 0022459 79T

