

MITSUBISHI (DGTL LOGIC)

M54530P**7-UNIT 400mA DARLINGTON TRANSISTOR ARRAY WITH CLAMP DIODE****DESCRIPTION**

The M54530P, 7-channel sink driver, consists of 14 NPN transistors connected to form seven high current gain driver pairs.

FEATURES

- High output sustaining voltage to 40V
- High output sink current to 400mA
- Integral diodes for transient suppression
- PMOS compatible input
- Wide operating temperature range ($T_a = -20 \sim +75^\circ\text{C}$)

APPLICATION

Relay and printer driver, LED or incandescent display digit driver, Interfacing for standard MOS/BIPOLAR logics

FUNCTION

The M54530P is comprised of seven NPN darlington driver pairs with $20\text{k}\Omega$ series input resistors. Between pin 9 and each output, there are integral diodes for inductive load transient suppression. All emitters and the substrate are connected together to pin 8. The outputs are capable of sinking 400mA and will withstand 40V in the OFF state.

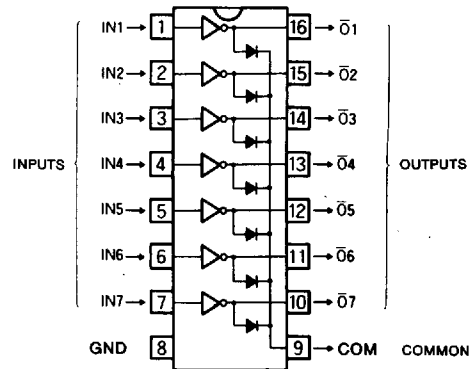
PIN CONFIGURATION (TOP VIEW)

Outline 16P4

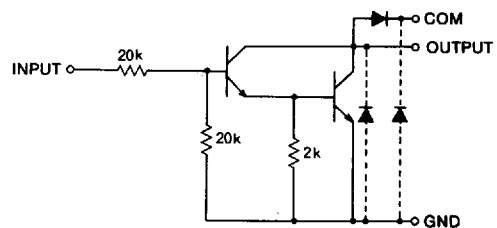
CIRCUIT SCHEMATIC

The diodes shown by broken line are parasite diodes and must not be used.

Unit : Ω **ABSOLUTE MAXIMUM RATINGS** ($T_a = -20 \sim +75^\circ\text{C}$, unless otherwise noted)

Symbol	Parameter	Conditions	Ratings	Unit
V_{CEO}	Output sustaining voltage	Transistor OFF	$-0.5 \sim +40$	V
I_C	Collector current per channel	Transistor ON	400	mA
V_i	Input voltage		$-0.5 \sim +40$	V
I_F	Clamp diode forward current		400	mA
V_R	Clamp diode reverse voltage		$-0.5 \sim +40$	V
P_d	Power dissipation	$T_a = 25^\circ\text{C}$	1.47	W
T_{opr}	Operating temperature		$-20 \sim +75$	$^\circ\text{C}$
T_{stg}	Storage temperature		$-55 \sim +125$	$^\circ\text{C}$

7-UNIT 400mA DARLINGTON TRANSISTOR ARRAY WITH CLAMP DIODE

RECOMMENDED OPERATIONAL CONDITIONS ($T_a = -20 \sim +75^\circ\text{C}$, unless otherwise noted)

Symbol	Parameter		Limits			Unit
			Min	Typ	Max	
V_O	Output voltage		0		40	V
I_C	Collector current per channel	Percent duty cycle less than 8%	0		400	mA
		Percent duty cycle less than 30%	0		200	
V_{IH}	"H" Input voltage	$I_C = 400\text{mA}$	8		35	V
		$I_C = 200\text{mA}$	5		35	
V_{IL}	"L" Input voltage	$I_{oleak} = 50\mu\text{A}$	0		0.5	V

ELECTRICAL CHARACTERISTICS ($T_a = -20 \sim +75^\circ\text{C}$, unless otherwise noted)

Symbol	Parameter	Test conditions	Limits			Unit
			Min	Typ*	Max	
$V_{(BR)CEO}$	Output sustaining voltage	$I_{CER} = 100\mu\text{A}$	40			V
$V_{CE(sat)}$	Output saturation voltage	$V_I = 8\text{V}, I_C = 400\text{mA}$		1.3	2.4	V
		$V_I = 5\text{V}, I_C = 200\text{mA}$		1	1.6	
I_i	Input current	$V_I = 17\text{V}$		0.85	1.8	mA
		$V_I = 35\text{V}$		2.0	3.8	
V_F	Clamp diode forward voltage	$I_{FDI} = 400\text{mA}$		1.5	2.4	V
V_R	Clamp diode reverse voltage	$V_{R(D)} = 100\mu\text{A}$	40			V
h_{FE}	DC forward current gain	$V_{CE} = 4\text{V}, I_C = 300\text{mA}, T_a = 25^\circ\text{C}$	1000	3500		—

* : Typical values are at $T_a = 25^\circ\text{C}$.

TYPICAL CHARACTERISTICS

ALLOWABLE AVERAGE POWER DISSIPATION

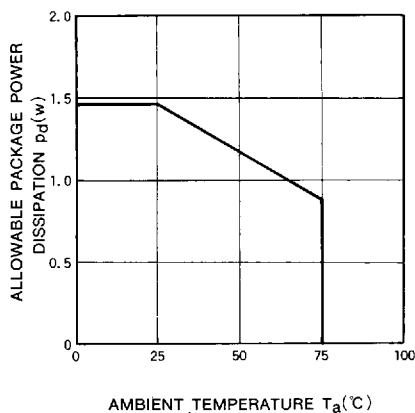

OUTPUT CURRENT CHARACTERISTICS

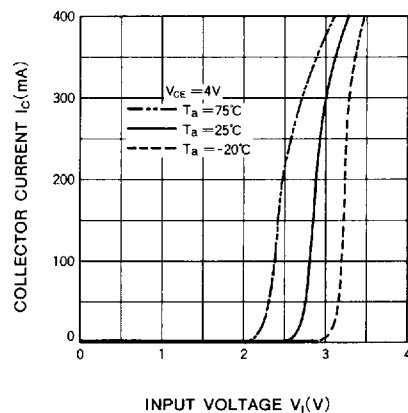

7-UNIT 400mA DARLINGTON TRANSISTOR ARRAY WITH CLAMP DIODE

ALLOWABLE COLLECTOR CURRENT AS A FUNCTION OF DUTY CYCLE

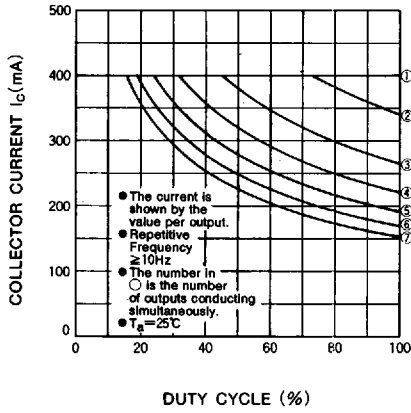

ALLOWABLE COLLECTOR CURRENT AS A FUNCTION OF DUTY CYCLE

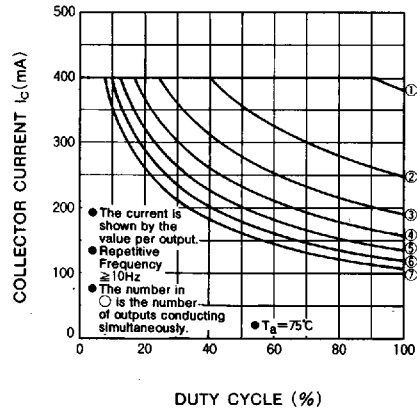

DC CURRENT GAIN CHARACTERISTICS

