

M62423FP

DIGITAL SOUND CONTROLLER FOR MINI-COMPONENT STEREO

DESCRIPTION

The M62423FP is a digital sound controller IC for miniature unit audio systems. The IC, with serial data sent from a microcomputer, makes it easy to realize karaoke functions (voice canceling) and tone quality/sound field control such as surround and 3-band tone control.

FEATURES

- 32-pin shrink DIP
- Capable of controlling each function by serial data
 - Bass/treble/Mid 0, ± 3 , ± 6 , ± 10 dB
 - Surround [ON/OFF]
 - Bass boost [ON/OFF]
 - Voice canceling [ON/OFF]
 - Mute [ON/OFF]

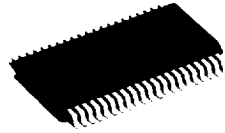

Outline 42P2R-A
0.8mm pitch 450mil SSOP
(8.4mm x 17.5mm x 2.0mm)

RECOMMENDED OPERATING CONDITIONS

- Supply voltage range V_{CC} , $V_{EE} = \pm 5.0$ to $\pm 8.0V$
- Rated supply voltage V_{CC} , $V_{EE} = \pm 7.0V$

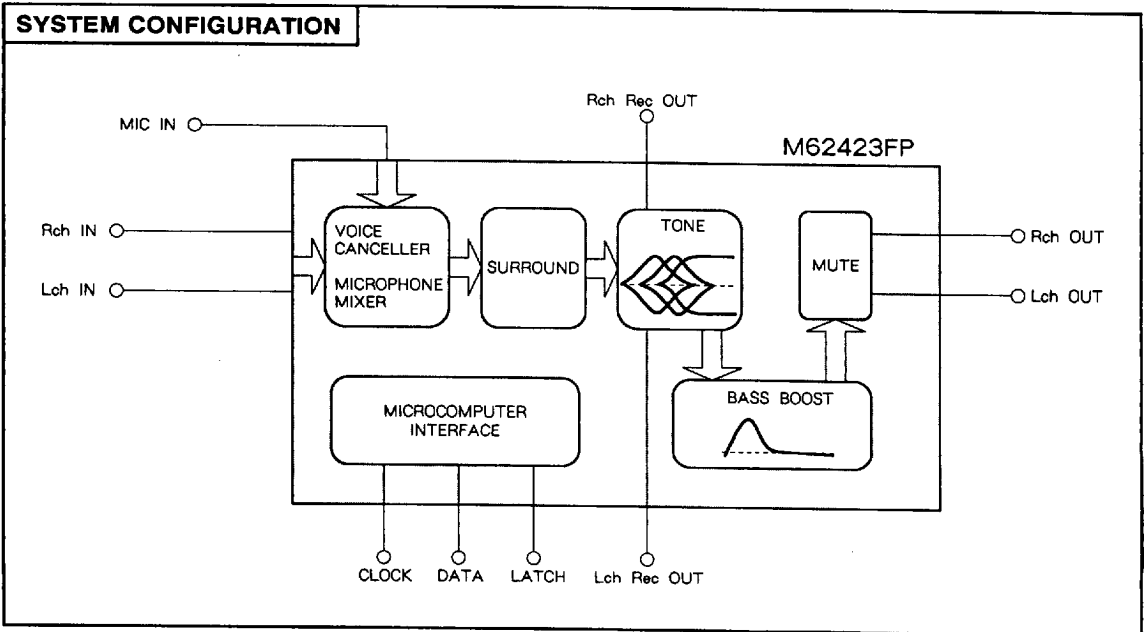

■ 6249826 0022234 558 ■



DIGITAL SOUND CONTROLLER FOR MINI-COMPONENT STEREO

PIN CONFIGURATION (TOP VIEW)

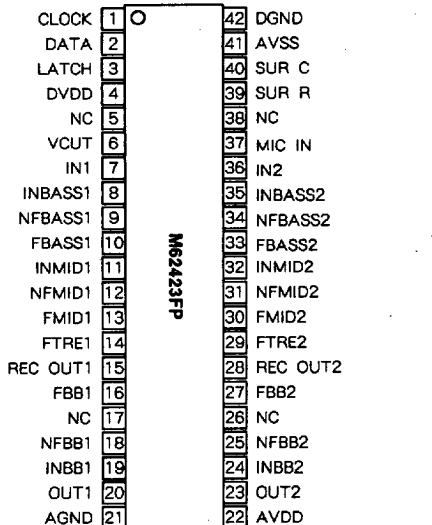

Outline 42P2R-A

NC: NO CONNECTION

IC INTERNAL BLOCK DIAGRAM

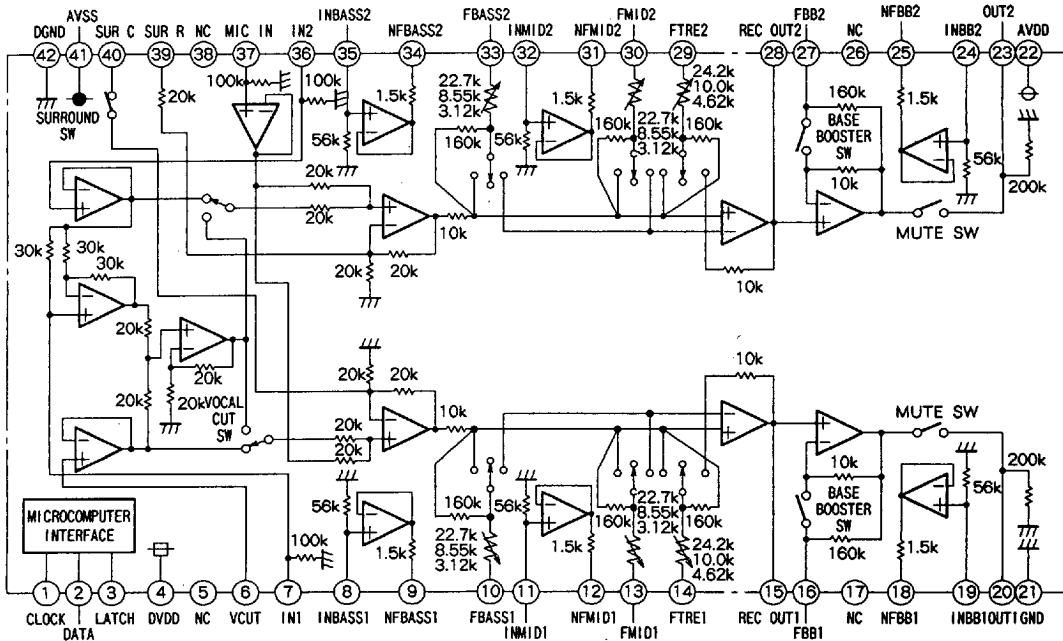

Unit Resistance : Ω

6249826 0022235 494



DIGITAL SOUND CONTROLLER FOR MINI-COMPONENT STEREO

ABSOLUTE MAXIMUM RATINGS

Symbol	Parameter	Ratings	Unit
AVDD, AVSS	Analog supply voltage	± 8.5	V
DVDD	Digital supply voltage	7.0	V
Pa	Power dissipation (Ta ≤ 25 °C)	1250	mW
Ke	Thermal derating (Ta > 25 °C)	9.5	mW/°C
ToPr	Operating temperature	-20 to +75	°C
Tstg	Storage temperature	-55 to +125	°C

ELECTRICAL CHARACTERISTICS (Ta = 25 °C, AVDD = 7V, AVSS = -7V, DVDD = 5V, unless otherwise noted.)

Tone control and bass boost are set to 0dB.)

(1) Power supply characteristics

Symbol	Parameter	Test conditions	Limits			Unit
			Min	Typ	Max	
AIDD	Circuit current of analog positive power supply	Current at pin ② with AVDD = 7V, AVSS = -7V No signal	-	22	-	mA
AISS	Circuit current of analog negative power supply	Circuit current at pin ① with AVDD = 7V, AVSS = -7V No signal	-	-22	-	mA
DIID	Circuit current of digital power supply	Current at pin ④ with DVDD = 5V No signal	-	0	-	μA

(2) Characteristics of the digital block

Symbol	Parameter	Test conditions	Limits			Unit
			Min	Typ	Max	
VIL	Input voltage ("L" level)	CLOCK, DATA, LATCH pins	0	-	0.3·DVDD	V
VIH	Input voltage ("H" level)		0.7·DVDD	-	DVDD	V
IIL	Output voltage ("L" level)	VIN = 0	-10	-	10	μA
IiH	Input current ("H" level)	VIN = DVDD	-	-	10	μA
FCLK	CLOCK frequency		-	-	250	kHz
twhc	CLOCK pulse width		4.0	-	-	μS
tSD	DATA setup time		1.0	-	-	μS
tHD	DATA hold time		1.0	-	-	μS
twhl	LATCH pulse width		2.0	-	-	μS
tSl	LATCH setup time		1.0	-	-	μS

6249826 0022236 320



DIGITAL SOUND CONTROLLER FOR MINI-COMPONENT STEREO

(3) Input/Output characteristics

Symbol	Parameter	Test conditions	Limits			Unit
			Min	Typ	Max	
R _{IN}	Input resistance	Pin ①, ②, T _a = 25 °C	50	100	200	kΩ
V _{IM}	Max. input voltage	Input to pin ①, ②, ③, output from pin ④, ⑤	3.0	4.0	-	V _{rms}
V _{ODC}	Output pin voltage	Pin ④, ⑤, no signal	-0.15	0	0.15	V
V _{REDC}		Pin ⑥, ⑦, no signal	-0.1	0	0.1	V
G _v	Pass gain	V _{IN} = 1V _{rms} , flat. pin ④, ⑤ - ①, ② gains	-1	0	1	dB
V _{ONO}	Output noise voltage	JIS-A filter, no signal	-	7.0	20	μV _{rms}
V _{RECNO}		R _g = 10kΩ	pin ④, ⑤	-	5.5	15
THD	Distortion factor	pin ④, ⑤. V _o = 0.5V _{rms} , R _L = 30kΩ	-	0.02	0.8	%
THD _{REC}		pin ⑥, ⑦. V _o = 0.5V _{rms} , R _L = 10kΩ	-	0.01	0.4	%
CT	Crosstalk between channels	Between pin ①, ② - ④, ⑤ lines	-60	-65	-	dB
CT _{REC}		Between pin ①, ② - ⑥, ⑦ lines	-60	-65	-	dB

(4) Tone control characteristics

Symbol	Parameter	Test conditions	Limits			Unit
			Min	Typ	Max	
G _{BOOST1}	Tone control voltage gain	3dB	2	3	4	dB
G _{BOOST2}		6dB	5	6	7	dB
G _{BOOST3}		10dB	8.5	10	11.5	dB
G _{CUT1}		-3dB	-4	-3	-2	dB
G _{CUT2}		-6dB	-7	-6	-5	dB
G _{CUT3}		-10dB	-11.5	-10	-8.5	dB
BALTON	Balance between channels	f = 1kHz, V _o = 1V _{rms} Each of boost and cut conditions	-1	0	+1	dB

(5) Bass boost characteristics

Symbol	Parameter	Test conditions	Limits			Unit
			Min	Typ	Max	
G _{DB}	Bass boost voltage gain	f = 1kHz, V _o = 1V _{rms} Pin ④, ⑤, R _L = 3.3k	8.5	10	11.5	dB
BALDD	Graphic equalizer balance between channels	f = 1kHz, V _o = 1V _{rms} Defference in pin ④ - ⑤ gain	-1	0	+1	dB

(6) Microphone amplifier input/output characteristics

Symbol	Parameter	Test conditions	Limits			Unit
			Min	Typ	Max	
R _{micin}	Input resistance	Pin ⑧	50	100	200	kΩ
V _{IMmic}	Max. input voltage	FLAT, R _L = 30kΩ, THD = 1% Measure input at pin ⑧, outputs at pin ④, ⑤	3.0	4.0	-	V _{rms}
G _{Vmic}	Pass gain	pin ④, ⑤ - ⑧ voltage gains V _o = 0.5V _{rms} , R _L = 30kΩ	-2	0	2	dB
THD _{mic}	Distortion factor	pin ④, ⑤ V _o = 0.5V _{rms} , R _L = 30kΩ	-	0.02	0.8	%
BAL _{mic}	Balance between channels	Difference in voltage gain between pin ④, ⑤	-1	0	1	dB

6249826 0022237 267



DIGITAL SOUND CONTROLLER FOR MINI-COMPONENT STEREO

DIGITAL CONTROL SPECIFICATIONS

Digital format

	D7	D6	D5	D4	D3	D2	D1	D0	
DATA 0 (MSB)	MODE SELECT 0	BASS BOOST OFF/ON	SURROUND OFF/ON	OUTPUT MUTE OFF/ON	VOCAL CUT OFF/ON	---	---	---	(LSB)
DATA 1 (MSB)	MODE SELECT 1	TONE CONTROL MODE 01: BASS 10: TREBLE 11: MID		---	---	BOOST/CUT VOLUME			(LSB)

Signal name	Function	Signal name	Function																																								
D0	Fixed to "0"	D0 Tone boosting/ cutting volume	<table border="1"> <thead> <tr> <th>D2</th> <th>D1</th> <th>D0</th> <th>Boosting / cutting volume</th> <th>D2</th> <th>D1</th> <th>D0</th> <th>Boosting / cutting volume</th> </tr> </thead> <tbody> <tr> <td>0</td> <td>0</td> <td>0</td> <td>+0dB</td> <td>1</td> <td>0</td> <td>0</td> <td>-0dB</td> </tr> <tr> <td>0</td> <td>0</td> <td>1</td> <td>+3dB</td> <td>1</td> <td>0</td> <td>1</td> <td>-3dB</td> </tr> <tr> <td>0</td> <td>1</td> <td>0</td> <td>+6dB</td> <td>1</td> <td>1</td> <td>0</td> <td>-6dB</td> </tr> <tr> <td>0</td> <td>1</td> <td>1</td> <td>+10dB</td> <td>1</td> <td>1</td> <td>1</td> <td>-10dB</td> </tr> </tbody> </table>	D2	D1	D0	Boosting / cutting volume	D2	D1	D0	Boosting / cutting volume	0	0	0	+0dB	1	0	0	-0dB	0	0	1	+3dB	1	0	1	-3dB	0	1	0	+6dB	1	1	0	-6dB	0	1	1	+10dB	1	1	1	-10dB
D2	D1			D0	Boosting / cutting volume	D2	D1	D0	Boosting / cutting volume																																		
0	0			0	+0dB	1	0	0	-0dB																																		
0	0			1	+3dB	1	0	1	-3dB																																		
0	1	0	+6dB	1	1	0	-6dB																																				
0	1	1	+10dB	1	1	1	-10dB																																				
D1	Fixed to "0"																																										
D2	Fixed to "0"																																										
D3	Vocal cut Vocal cut disabled by "0" Vocal cut enabled by "1"	D3	Fixed to "0"																																								
D4	Output mute Output mute disabled by "0" Output mute enabled by "1"	D4	Fixed to "0"																																								
D5	Sorround Sorround disabled by "0" Sorround enabled by "1"	D5 Tone control mode	<table border="1"> <thead> <tr> <th>D5</th> <th>D6</th> <th>Mode</th> </tr> </thead> <tbody> <tr> <td>0</td> <td>1</td> <td>Bass</td> </tr> <tr> <td>1</td> <td>0</td> <td>Treble</td> </tr> <tr> <td>1</td> <td>1</td> <td>MID</td> </tr> </tbody> </table>	D5	D6	Mode	0	1	Bass	1	0	Treble	1	1	MID																												
D5	D6			Mode																																							
0	1			Bass																																							
1	0	Treble																																									
1	1	MID																																									
D6	Bass boost Bass boost disabled by "0" Bass boost enabled by "1"																																										
D7	Mode select Data 0 is selected by "0"	D7	Mode select Data 1 is selected by "1"																																								

DATA TIMING (Recommended conditions)

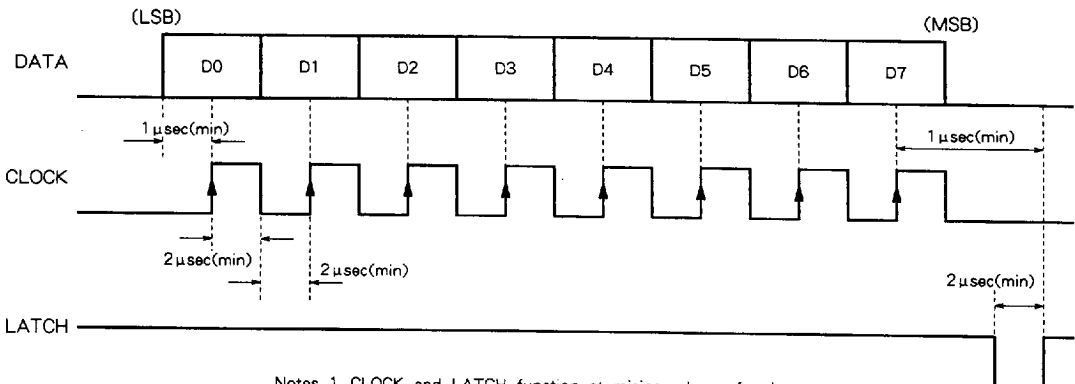

6249826 0022238 1T3



DIGITAL SOUND CONTROLLER FOR MINI-COMPONENT STEREO

FUNCTION DESCRIPTION

(1) Tone controller equivalent circuit

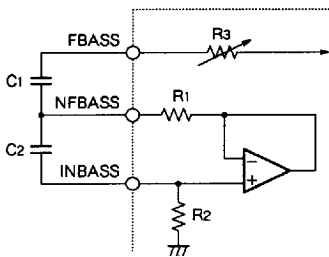

CENTER FREQUENCY

$$f_0 = 1/2\pi \sqrt{C1 \cdot C2 \cdot R1 \cdot R2} \text{ [Hz]}$$

$$Q = \sqrt{(C2 \cdot R2) / (C1 \cdot R1)}$$

EXAMPLE : BASS BAND (f = 150Hz)

R1 = 1.5k Ω , R2 = 56k Ω

C1 = 0.82 μ , C2 = 0.015 μ

Fig. 1 A circuit equivalent to the inside of the tone controller

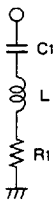
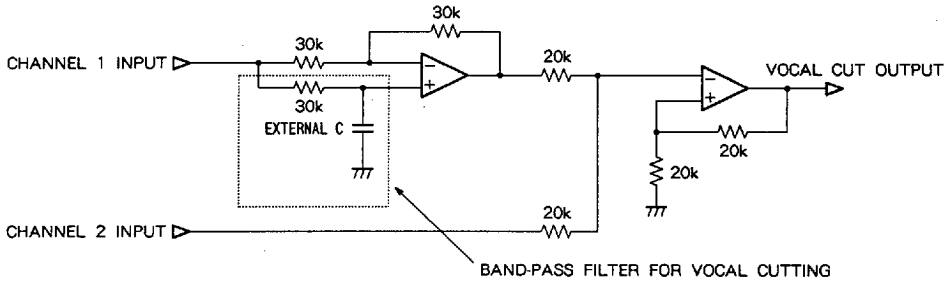

Fig. 2 is equivalent to Fig.1. To convert component constants, the equation below is used.

$$L = C2 \cdot R1 \cdot R2$$

Fig. 2 An equivalent circuit using L

(2) Vocal cut block equivalent circuit



Note. The vocal cut output is monaural.

(3) Surround block equivalent circuit

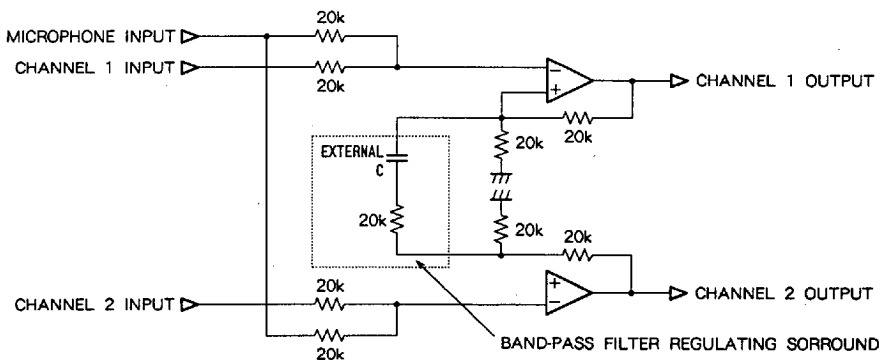

6249826 0022239 03T



DIGITAL SOUND CONTROLLER FOR MINI-COMPONENT STEREO

TYPICAL CHARACTERISTICS

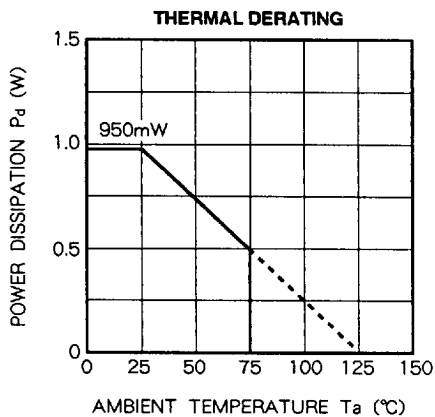

APPLICATION EXAMPLE

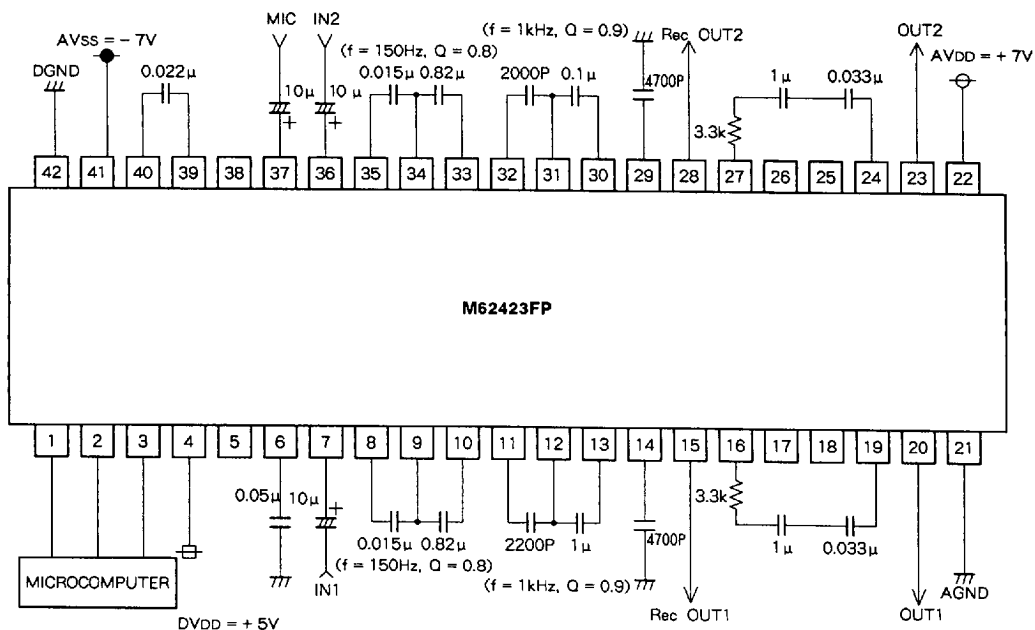

Unit Capacitance : F

6249826 0022240 851

