

LINEAR IC

FREQUENCY-TO-VOLTAGE CONVERTER

MB4206

FREQUENCY-TO-VOLTAGE CONVERTER WITH SINGLE POWER SUPPLY COMPARATOR

The Fujitsu MB4206 is a frequency-to-voltage converter with an on-chip comparator. The MB4206 uses a charge pump driven by a positive-edge Schmitt trigger/flip-flop input so stable operation is achieved against noise signal input. The output of the comparator is zener-clamped to a reference voltage; thus, a precise hysteresis output is obtained. The overall design makes the circuit fairly tolerant of imperfections in the input waveform.

- Conversion coefficient determined by RC pair:

$$V_{O(F)} = F_{IN} \cdot R_T \cdot C_T \cdot V_R$$
- Positive edge-triggered frequency input
- Equal internal reference high-level output and comparator high level output
- Package
 - 8-pin plastic SIP package (Suffix: -PS)

■ ABSOLUTE MAXIMUM RATINGS (see NOTE)

(Ta= 25°C)

Rating	Symbol	Value	Unit
Power Supply Voltage	VCC	24	V
Surge Voltage at VCC	VCC(S)	40 (t ≤ 50ms)	V
Zener Current	I _Z	20	mA
Power Dissipation	P _D	300 (Ta ≤ 85°C)	mW
Operating Temperature	T _{OP}	-30 to +85	°C
Storage Temperature	T _{STG}	-55 to +125	°C

NOTE: Permanent device damage may occur if the above **Absolute Maximum Ratings** are exceeded. Functional operation should be restricted to the conditions as detailed in the operational sections of this data sheet. Exposure to absolute maximum rating conditions for extended periods may affect device reliability.

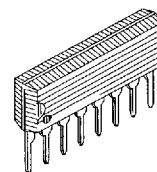

PLASTIC PACKAGE
(SIP-08P-M03)

PIN ASSIGNMENTS

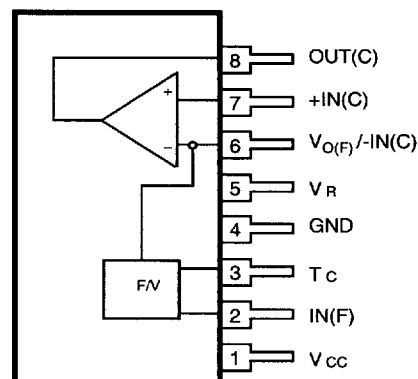

(Front View)

Fig. 1 — MB4206 BLOCK DIAGRAM

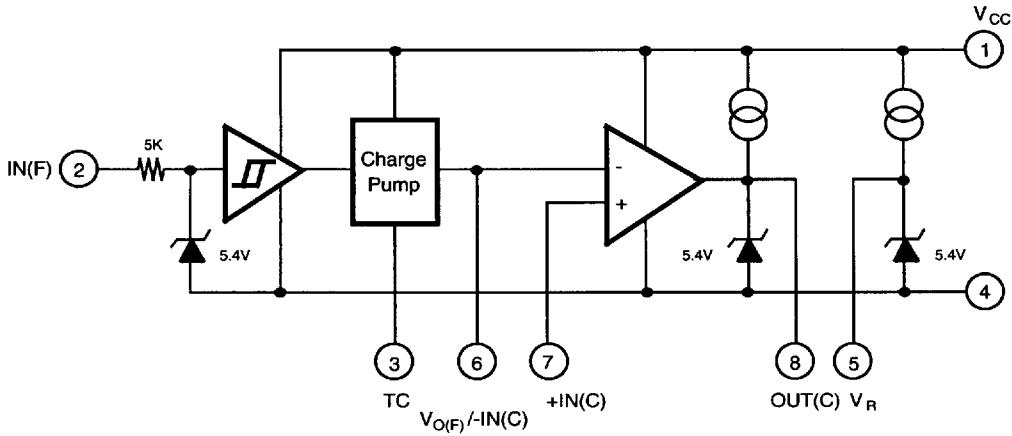
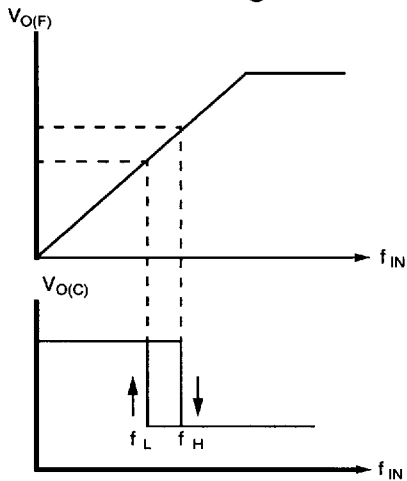
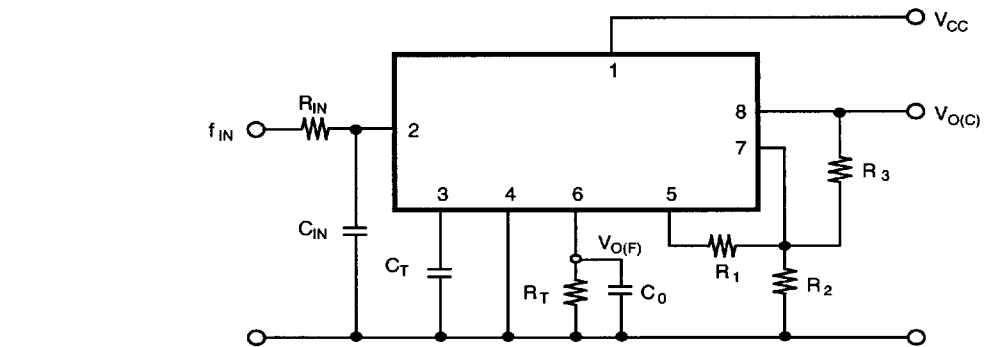

FIG. 2 — TYPICAL HOOKUP AND OPERATING PARAMETERS



The following equations define the operating frequency of the comparator.

$$f_H \doteq \frac{1}{C_T R_T} \cdot \frac{R_2}{R_2 + \frac{R_1 R_3}{R_1 + R_3}}$$

$$f_L \doteq \frac{1}{C_T R_T} \cdot \frac{R_2 R_3}{R_1 R_2 + R_1 R_3 + R_2 R_3}$$

R_{IN} and C_{IN} are needed when input noise is excessive.

■ ELECTRICAL CHARACTERISTICS

(Ta = 25°C, VCC = 12V)

Parameter	Symbol	Condition	Value			Unit	
			Min	Typ	Max		
Power Supplies	Power Supply Current	ICC	-	7.0	10.0	mA	
	Power Supply Voltage	VCC	6.5	-	24	V	
	Reference Voltage	VR	IL(R)=1mA	5.0	5.4	5.8	V
	Reference Voltage Temperature Coefficient		IL(R)=1mA	-	+1.4	-	mV/°C
F/V Converter	Input High Voltage	VIH		2.4	-	24	V
	Input Low Voltage	VIL		0	-	1.2	V
	Positive-edge			1	-	-	V/ms
	Negative-edge			0.1	-	-	V/ms
	Input Current	II	VIH(F)=24V	-	4	8	mA
			VIL(F)=1.2V	-	-	0.1	mA
	Output Current	IO	VTC=2.5V	0.26	0.4	0.58	mA
	F/V Coefficient ^{*1}	K	CT=0.1μF, RT=47kΩ, f=100Hz	0.9	1.0	1.1	-
Linearity ^{*2}		CT=0.1μF, RT=47kΩ	-	±0.3	-	%	
Comparator	Input Offset Voltage	VIO		-	2.0	10	mV
	Input Bias Current ^{*3}	II		-	0.5	3.0	μA
	Common Mode Input Voltage ^{*4}	VICM		0	-	VR	V
	Voltage Gain	AV	RL=10kΩ	-	100	-	dB
	Output Voltage	VOL	ISINK=3mA	-	0.1	0.2	V
		VOH	IL=0.5mA	5.0	5.4	5.8	V
	Sink Current	ISINK	VOL ≤ 1V	8	22	-	mA

Note: *1 $V_{O(F)} = K \cdot V_R \cdot C_T \cdot R_T \cdot f$

*2 With $f_{IN} = 100\text{Hz}$ as a reference, linearity is defined as the straight-line deviation over an input frequency range of 50- to - 150 Hz — see TYPICAL PERFORMANCE CHARACTERISTICS.

*3 The current flows from IC.

*4 If VCC is lower than VR, use (VCC-2).

Fig. 3 — TEST CIRCUIT

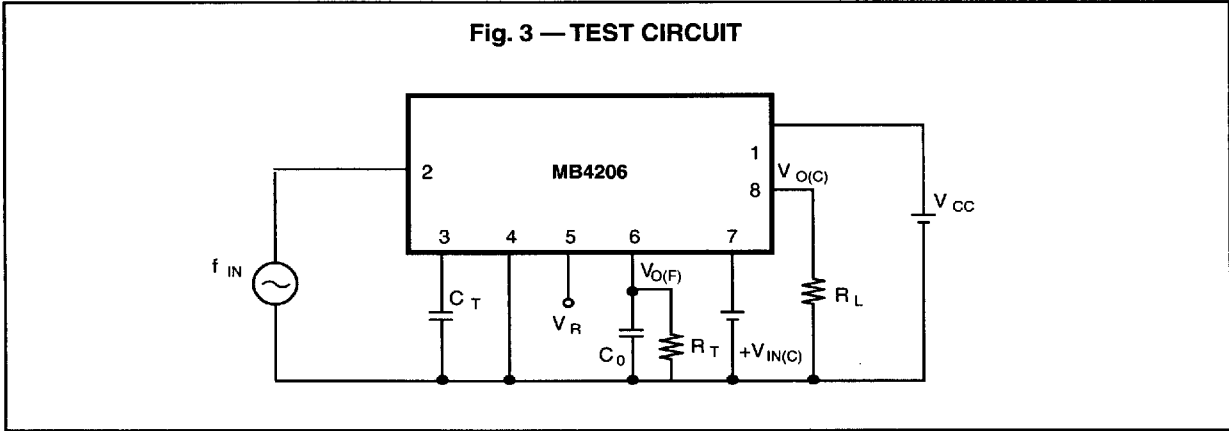

■ **TYPICAL PERFORMANCE CHARACTERISTICS**

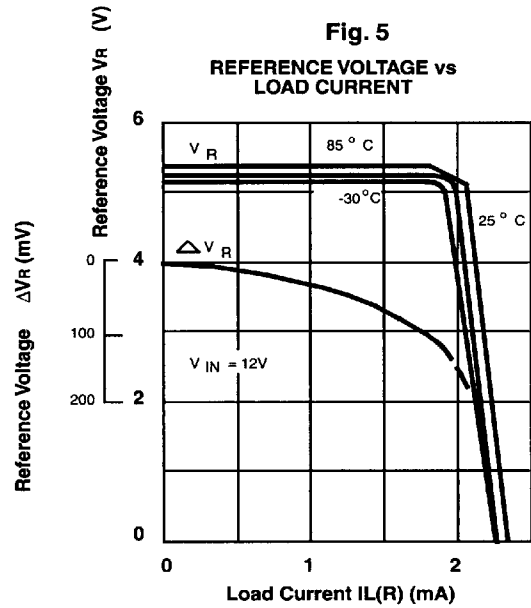
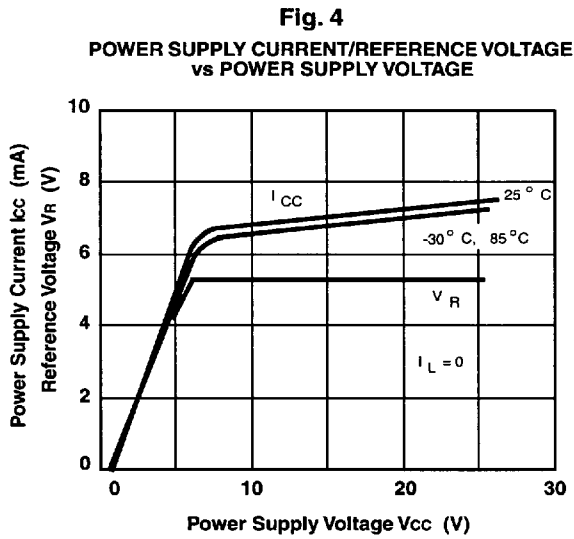

■ TYPICAL PERFORMANCE CHARACTERISTICS (Continued)

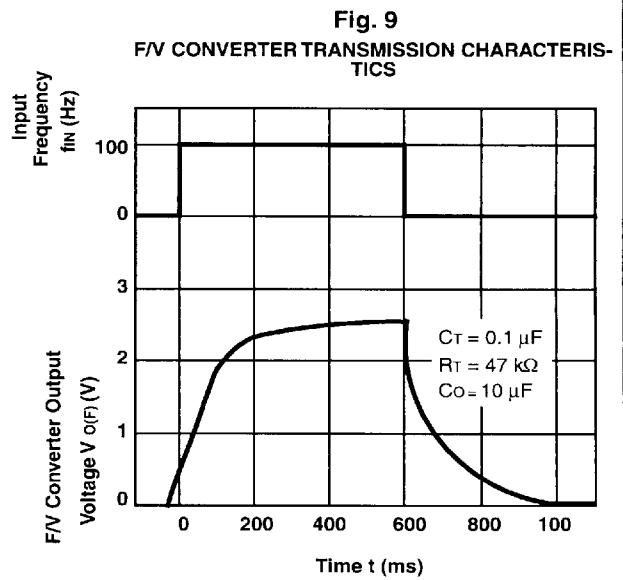
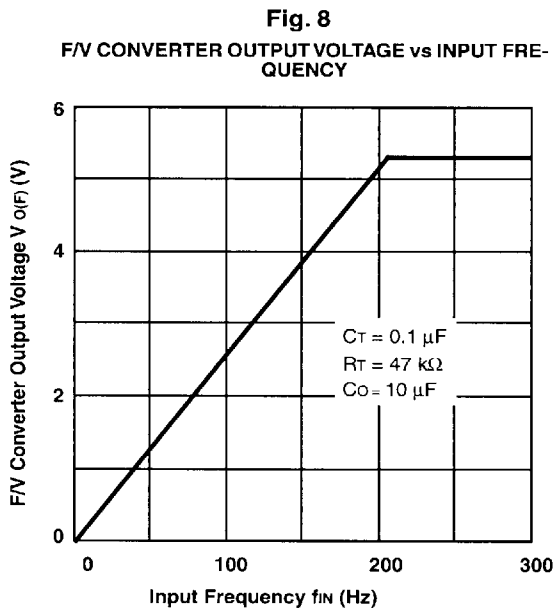
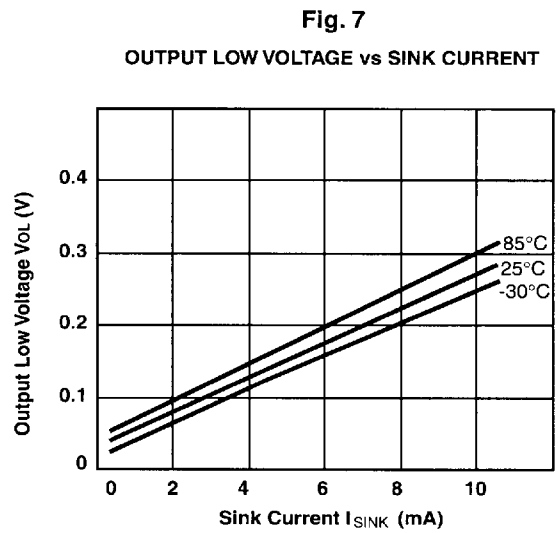
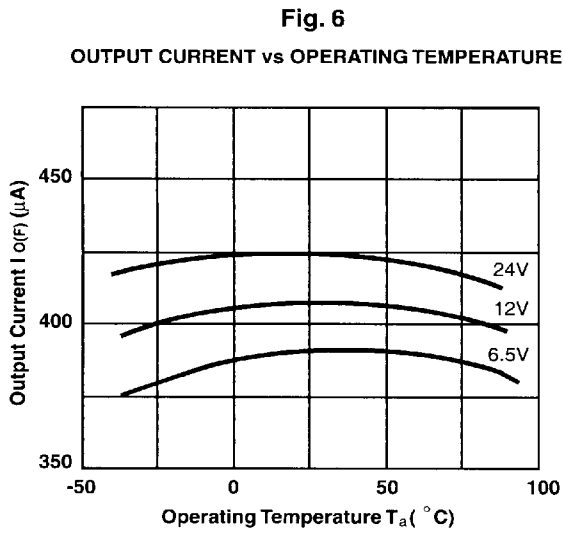

■ PACKAGE DIMENSIONS

