

## DUAL OPERATIONAL AMPLIFIERS

- LOW POWER CONSUMPTION
- LARGE INPUT VOLTAGE RANGE
- NO LATCH-UP
- HIGH GAIN
- SHORT-CIRCUIT PROTECTION
- NO FREQUENCY COMPENSATION REQUIRED

### DESCRIPTION

The MC1458 is a high performance monolithic dual operational amplifier constructed on a single silicon chip. It is intended for a wide range of analog applications.

- Summing amplifier
- Voltage follower
- Integrator
- Active filter
- Function generator

The high gain and wide range of operating voltages provide superior performance in integrator, summing amplifier, and general feedback applications.

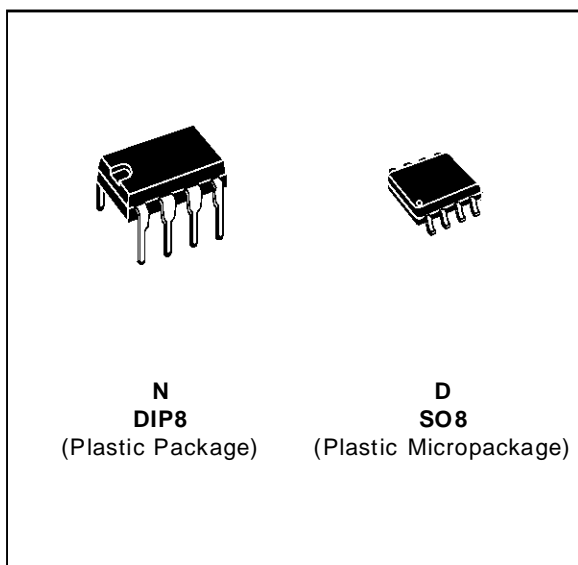

### ORDER CODES

Part Number	Temperature Range	Package	
		N	D
MC1458	0, +70°C	•	•
MC1458I	-40, +105°C	•	•
MC1558	-55, +125°C	•	•

**Example :** MC1458H

1458-01 TEL

### PIN CONNECTIONS (top view)

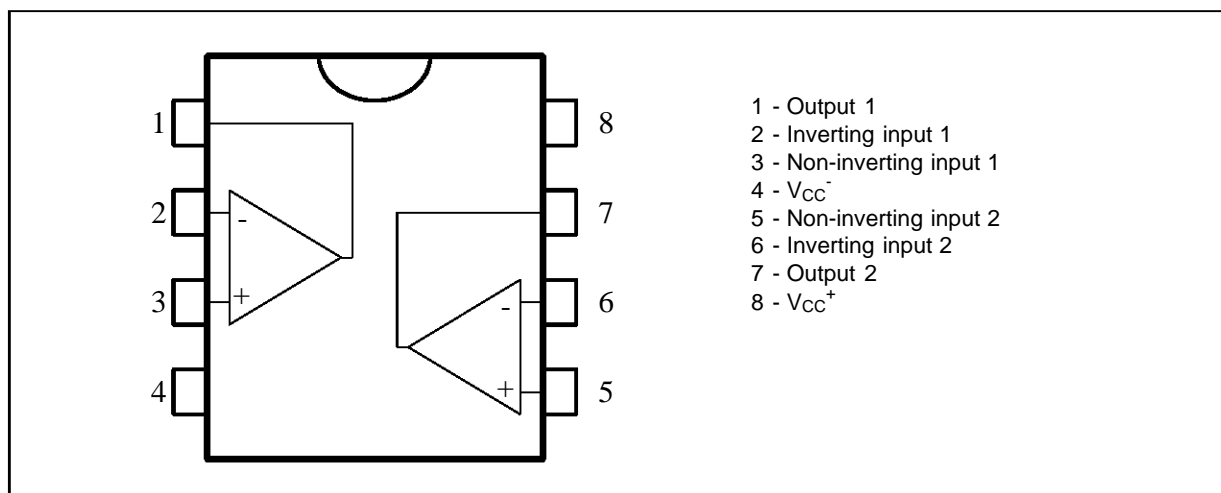

**SCHEMATIC DIAGRAM**

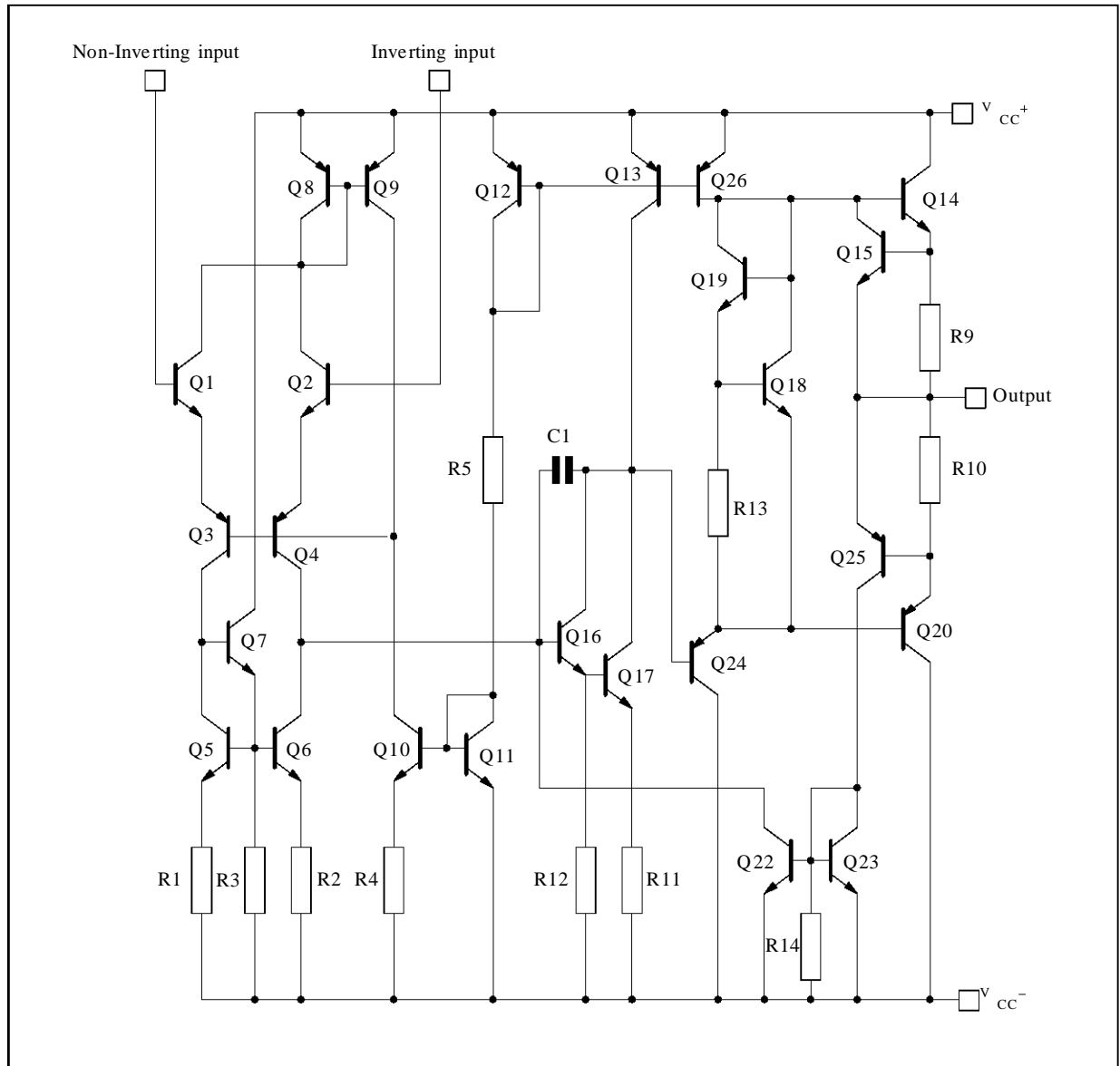

1458-03.EPS

**ABSOLUTE MAXIMUM RATINGS**

Symbol	Parameter	MC1458	MC1458I	MC1558	Unit
V <sub>CC</sub>	Supply Voltage	±22	±22	±22	V
V <sub>i</sub>	Input Voltage	±15	±15	±15	V
V <sub>id</sub>	Differential Input Voltage	±30	±30	±30	V
P <sub>tot</sub>	Power Dissipation	D Suffix N Suffix 300 500			mW
	Output Short-circuit Duration	Infinite			
T <sub>oper</sub>	Operating Free-air Temperature Range	0 to +70	-40 to +105	-55 to +125	°C
T <sub>stg</sub>	Storage Temperature Range	-65 to +150	-65 to +150	-65 to +150	°C

1458-02.TEL

**ELECTRICAL CHARACTERISTICS**V<sub>CC</sub> = ±15V, T<sub>amb</sub> = 25°C, (unless otherwise specified)

Symbol	Parameter	MC1458 - 1458I - 1558			Unit
		Min.	Typ.	Max.	
V <sub>io</sub>	Input Offset Voltage (R <sub>S</sub> ≤ 10kΩ) T <sub>amb</sub> = 25°C T <sub>min.</sub> ≤ T <sub>amb</sub> ≤ T <sub>max.</sub>		1	5 6	mV
I <sub>io</sub>	Input Offset Current T <sub>amb</sub> = 25°C T <sub>min.</sub> ≤ T <sub>amb</sub> ≤ T <sub>max.</sub>		2	200 300	nA
I <sub>ib</sub>	Input Bias Current T <sub>amb</sub> = 25°C T <sub>min.</sub> ≤ T <sub>amb</sub> ≤ T <sub>max.</sub>		30	500 800	nA
A <sub>vd</sub>	Large Signal Voltage Gain (V <sub>O</sub> = ±10V, R <sub>L</sub> = 2kΩ) T <sub>amb</sub> = 25°C T <sub>min.</sub> ≤ T <sub>amb</sub> ≤ T <sub>max.</sub>	50 25	200		V/mV
SVR	Supply Voltage Rejection Ratio (R <sub>S</sub> ≤ 10kΩ) T <sub>amb</sub> = 25°C T <sub>min.</sub> ≤ T <sub>amb</sub> ≤ T <sub>max.</sub>	77 77	90		dB
I <sub>CC</sub>	Supply Current, all Amp, no Load T <sub>amb</sub> = 25°C T <sub>min.</sub> ≤ T <sub>amb</sub> ≤ T <sub>max.</sub>		2.3	5 6	mA
V <sub>icm</sub>	Input Common Mode Voltage Range T <sub>amb</sub> = 25°C T <sub>min.</sub> ≤ T <sub>amb</sub> ≤ T <sub>max.</sub>	±12 ±12			V
CMR	Common-mode Rejection Ratio (R <sub>S</sub> ≤ 10 kΩ) T <sub>amb</sub> = 25°C T <sub>min.</sub> ≤ T <sub>amb</sub> ≤ T <sub>max.</sub>	70 70	90		dB
I <sub>OS</sub>	Output Short-circuit Current T <sub>amb</sub> = 25°C	10	20	35	mA
±V <sub>OPP</sub>	Output Voltage Swing T <sub>amb</sub> = 25°C T <sub>min.</sub> ≤ T <sub>amb</sub> ≤ T <sub>max.</sub>	12 10 12 10	14 13		V
SR	Slew Rate (V <sub>I</sub> = ±10V, R <sub>L</sub> = 2kΩ, C <sub>L</sub> = 100pF, T <sub>amb</sub> = 25°C, unity gain)	0.2	0.8		V/μs
t <sub>r</sub>	Rise Time (V <sub>I</sub> = 20mV, R <sub>L</sub> = 2kΩ, C <sub>L</sub> = 100pF, T <sub>amb</sub> = 25°C, unity gain)		0.3		μs
K <sub>OV</sub>	Overshoot (V <sub>I</sub> = 20mV, R <sub>L</sub> = 2kΩ, C <sub>L</sub> = 100pF, T <sub>amb</sub> = 25°C, unity gain)		5		%
R <sub>I</sub>	Input Resistance	0.3	2		MΩ
Z <sub>ic</sub>	Common-mode Input Impedance		200		MΩ
C <sub>I</sub>	Input Capacitance		1.4		pF
R <sub>O</sub>	Output Resistance		75		Ω
FPB	Full Power Bandwidth (R <sub>L</sub> = 2kΩ, V <sub>O</sub> ≥ ±10V, A <sub>VD</sub> = 1, THD ≤ 5%)		14		KHz
B	Unity Gain Bandwidth (V <sub>I</sub> = 10mV, R <sub>L</sub> = 2kΩ, C <sub>L</sub> = 100pF, T <sub>amb</sub> = 25°C)		1		MHz

1458-03 TEL

**ELECTRICAL CHARACTERISTICS** (continued)

Symbol	Parameter	MC1458 - 1458I MC1558			Unit
		Min.	Typ.	Max.	
GBP	Gain Bandwidth Product ( $V_i = 10\text{mV}$ , $R_L = 2\text{k}\Omega$ , $C_L = 100\text{pF}$ , $f = 100\text{kHz}$ , $T_{\text{amb}} = 25^\circ\text{C}$ )	0.4	1		MHz
THD	Total Harmonic Distortion ( $f = 1\text{kHz}$ , $A_V = 20\text{dB}$ , $R_L = 2\text{k}\Omega$ , $V_O = 2V_{\text{PP}}$ , $C_L = 100\text{pF}$ , $T_{\text{amb}} = 25^\circ\text{C}$ )		0.02		%
$e_n$	Equivalent Input Noise Voltage ( $f = \text{kHz}$ , $R_s = 100\Omega$ )		45		$\frac{\text{nV}}{\sqrt{\text{Hz}}}$
$\phi_m$	Phase Margin		65		Degrees
Am	Gain Margin		11		dB
$V_{O1}/V_{O2}$	Channel Separation		120		dB

1458-04 TEL

**OPEN LOOP VOLTAGE GAIN**

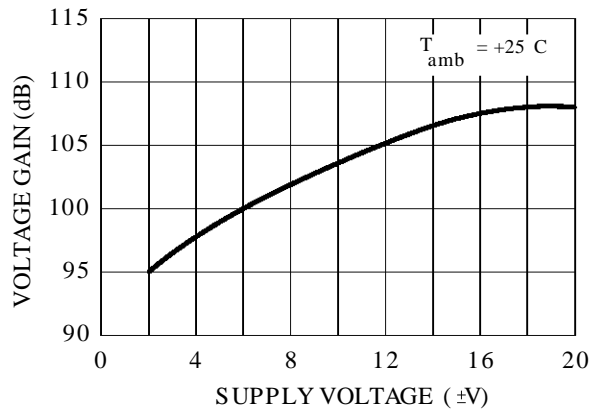

1458-04 EPS

**OPEN LOOP FREQUENCY RESPONSE**

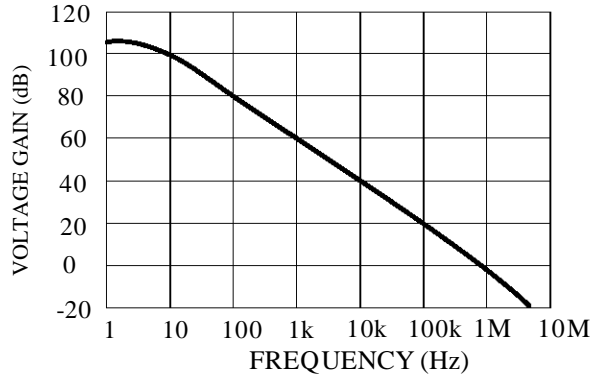

1458-05 EPS

**POWER BANDWIDTH  
(LARGE SIGNAL SWING)**

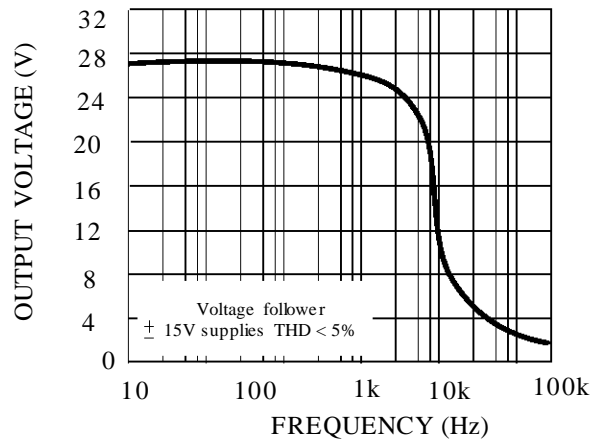

1458-06 EPS

**POWER CONSUMPTION**

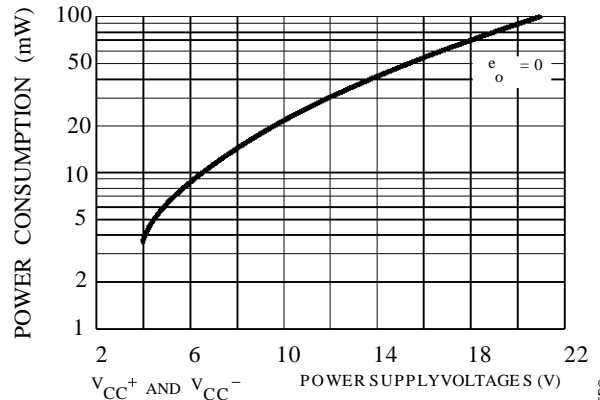

1458-07 EPS

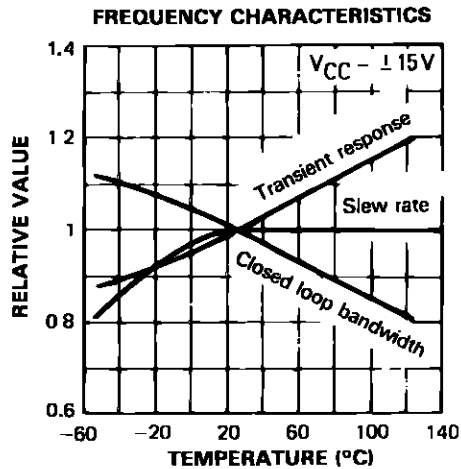
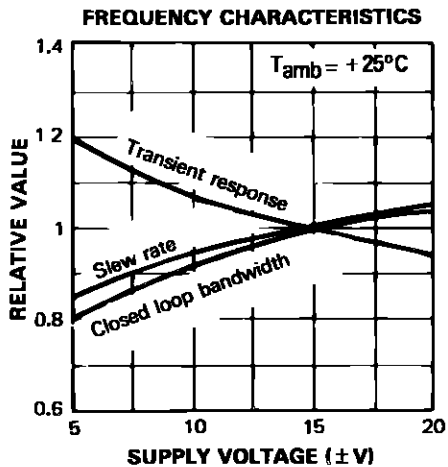
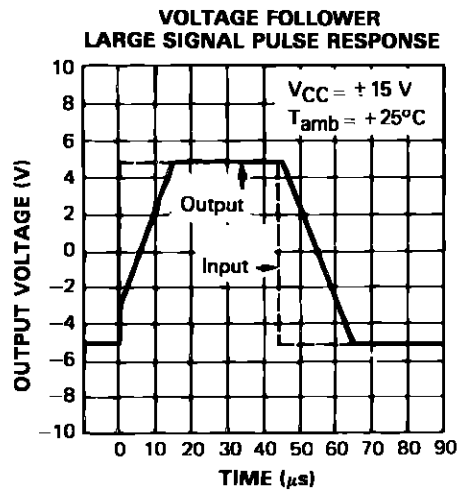
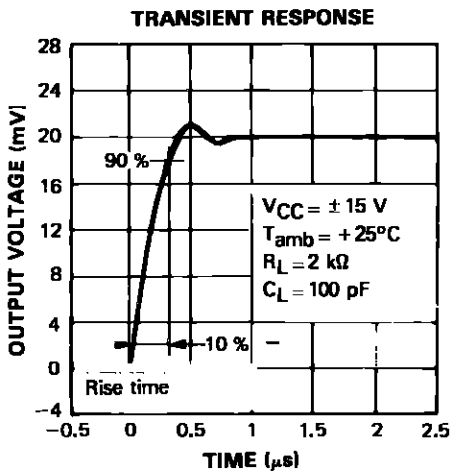
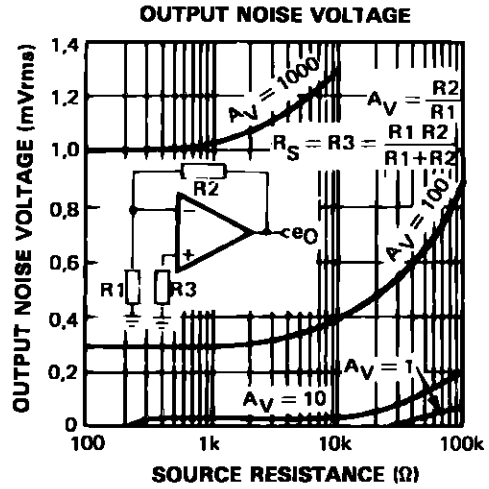
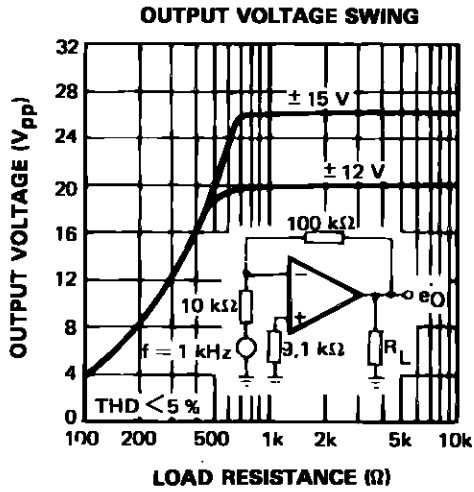

1458-08.EPS

1458-09.EPS

TYPICAL APPLICATIONS

LOW PASS FILTER

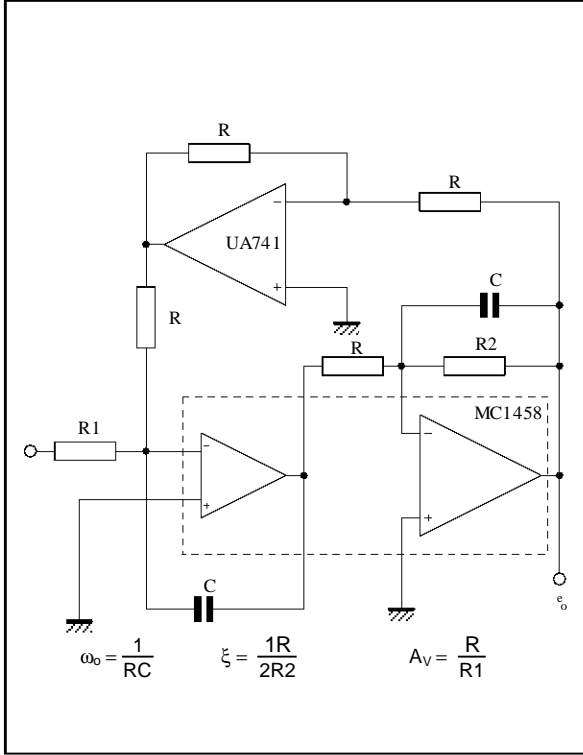

GIRATOR

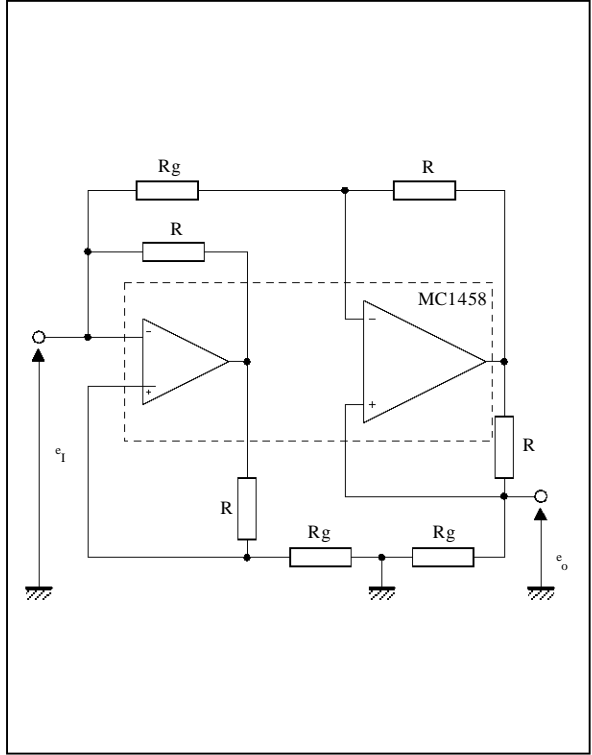

TURNABLE NOTCH FILTER

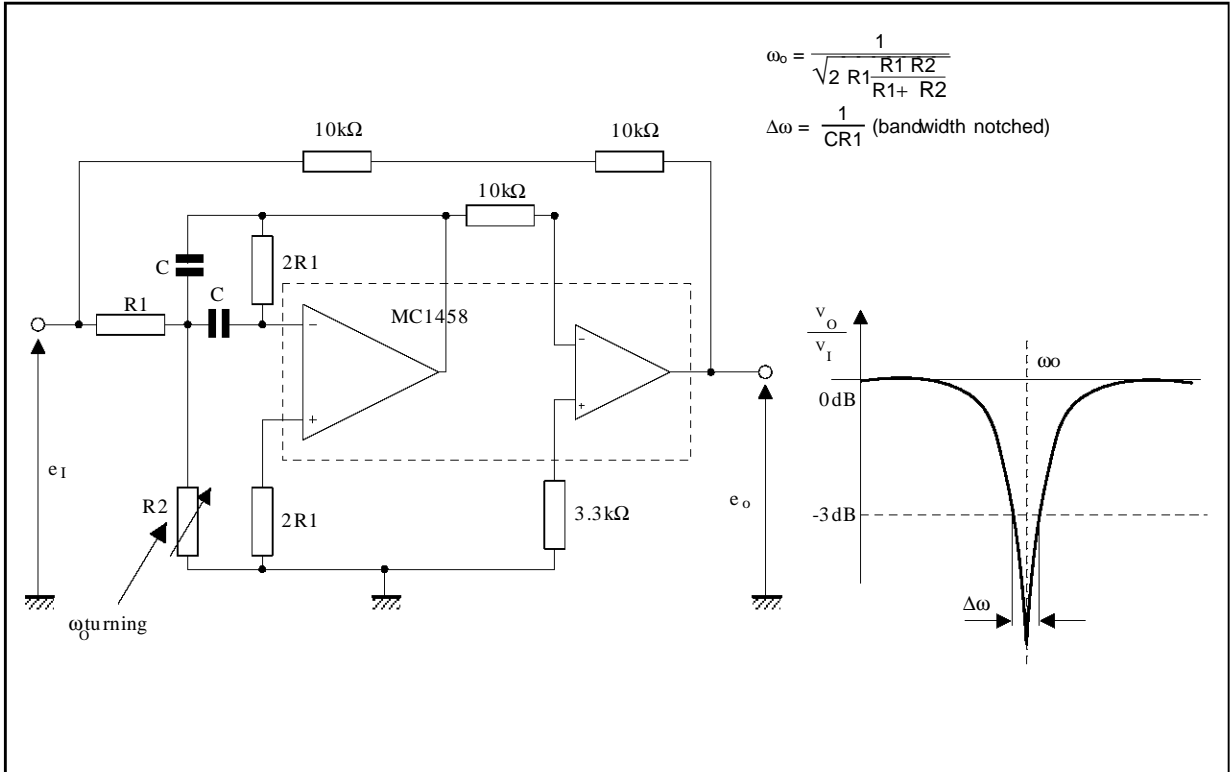

**PACKAGE MECHANICAL DATA**  
8 PINS - PLASTIC DIP OR CERDIP

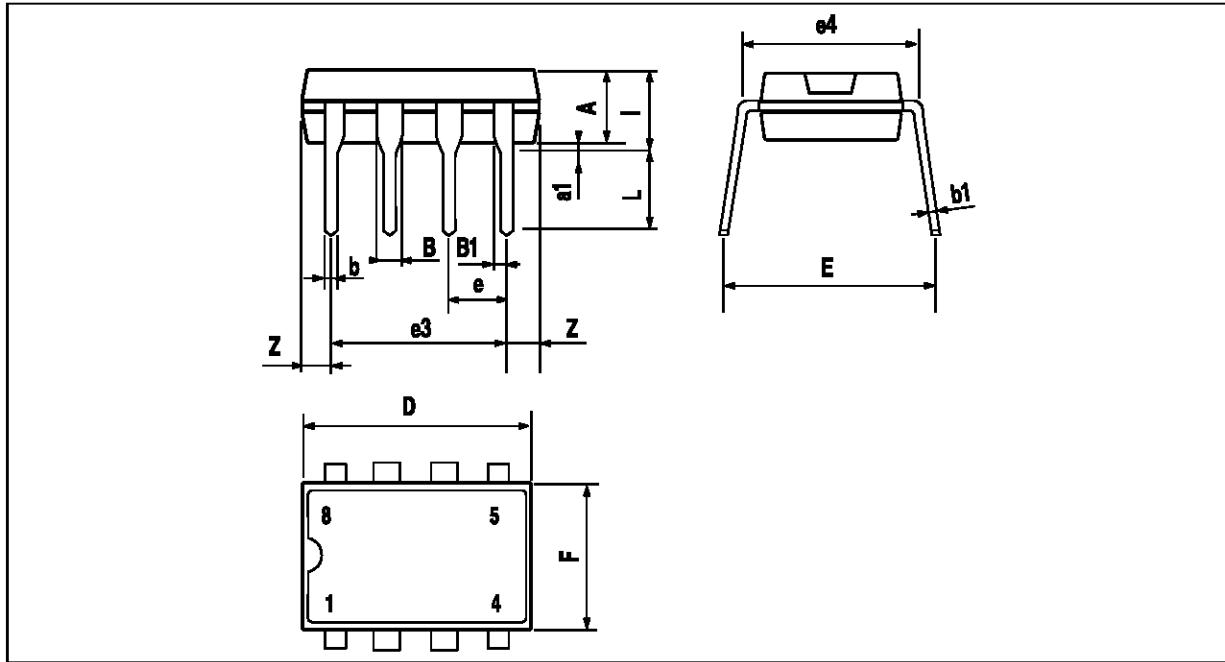

PM-DIP&EFS

Dimensions	Millimeters			Inches		
	Min.	Typ.	Max.	Min.	Typ.	Max.
A		3.32			0.131	
a1	0.51			0.020		
B	1.15		1.65	0.045		0.065
b	0.356		0.55	0.014		0.022
b1	0.204		0.304	0.008		0.012
D			10.92			0.430
E	7.95		9.75	0.313		0.384
e		2.54			0.100	
e3		7.62			0.300	
e4		7.62			0.300	
F			6.6			0.260
i			5.08			0.200
L	3.18		3.81	0.125		0.150
Z			1.52			0.060

DIP&TEL

MC1458 - MC1558

PACKAGE MECHANICAL DATA  
8 PINS - PLASTIC MICROPACKAGE (SO)

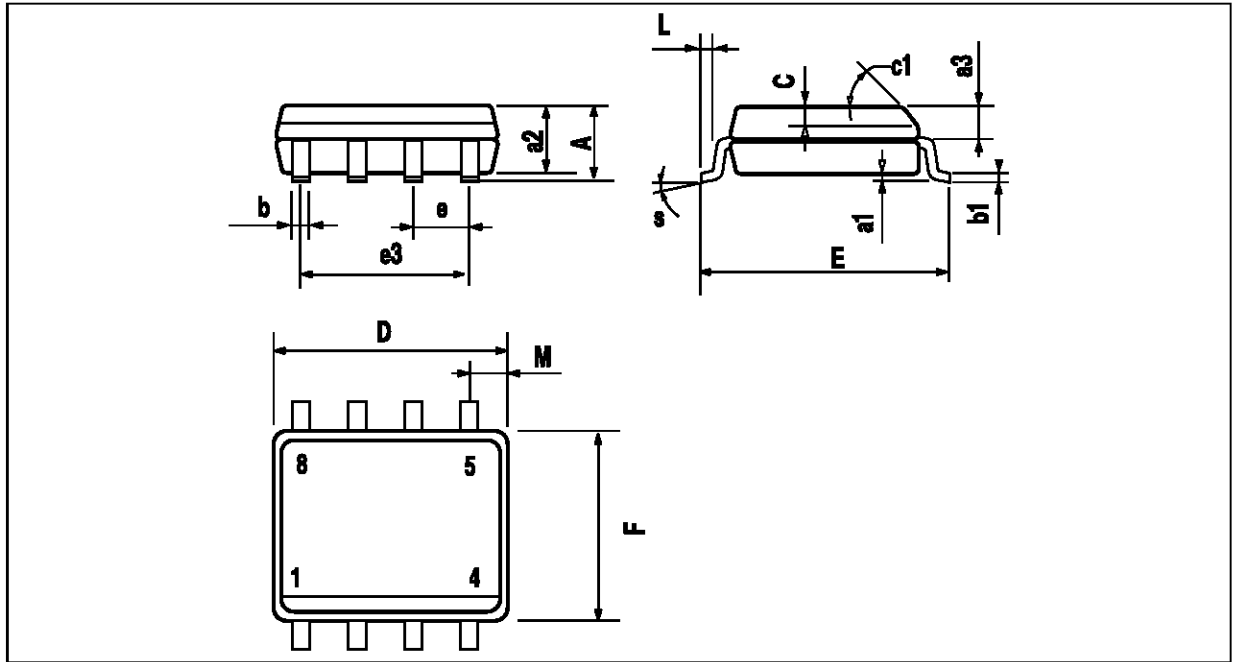

P1M-SOR-EFS

Dimensions	Millimeters			Inches		
	Min.	Typ.	Max.	Min.	Typ.	Max.
A			1.75			0.069
a1	0.1		0.25	0.004		0.010
a2			1.65			0.065
a3	0.65		0.85	0.026		0.033
b	0.35		0.48	0.014		0.019
b1	0.19		0.25	0.007		0.010
C	0.25		0.5	0.010		0.020
c1	45° (typ.)					
D	4.8		5.0	0.189		0.197
E	5.8		6.2	0.228		0.244
e		1.27			0.050	
e3		3.81			0.150	
F	3.8		4.0	0.150		0.157
L	0.4		1.27	0.016		0.050
M			0.6			0.024
S	8° (max.)					

SOR-TBL

Information furnished is believed to be accurate and reliable. However, SGS-THOMSON Microelectronics assumes no responsibility for the consequences of use of such information nor for any infringement of patents or other rights of third parties which may result from its use. No licence is granted by implication or otherwise under any patent or patent rights of SGS-THOMSON Microelectronics. Specifications mentioned in this publication are subject to change without notice. This publication supersedes and replaces all information previously supplied. SGS-THOMSON Microelectronics products are not authorized for use as critical components in life support devices or systems without express written approval of SGS-THOMSON Microelectronics.

© 1994 SGS-THOMSON Microelectronics - All Rights Reserved

SGS-THOMSON Microelectronics GROUP OF COMPANIES

Australia - Brazil - France - Germany - Hong Kong - Italy - Japan - Korea - Malaysia - Malta - Morocco - The Netherlands  
Singapore - Spain - Sweden - Switzerland - Taiwan - Thailand - United Kingdom - U.S.A.

ORDER CODE :